

PRODUCT NUMBER
SEE SHEET 3

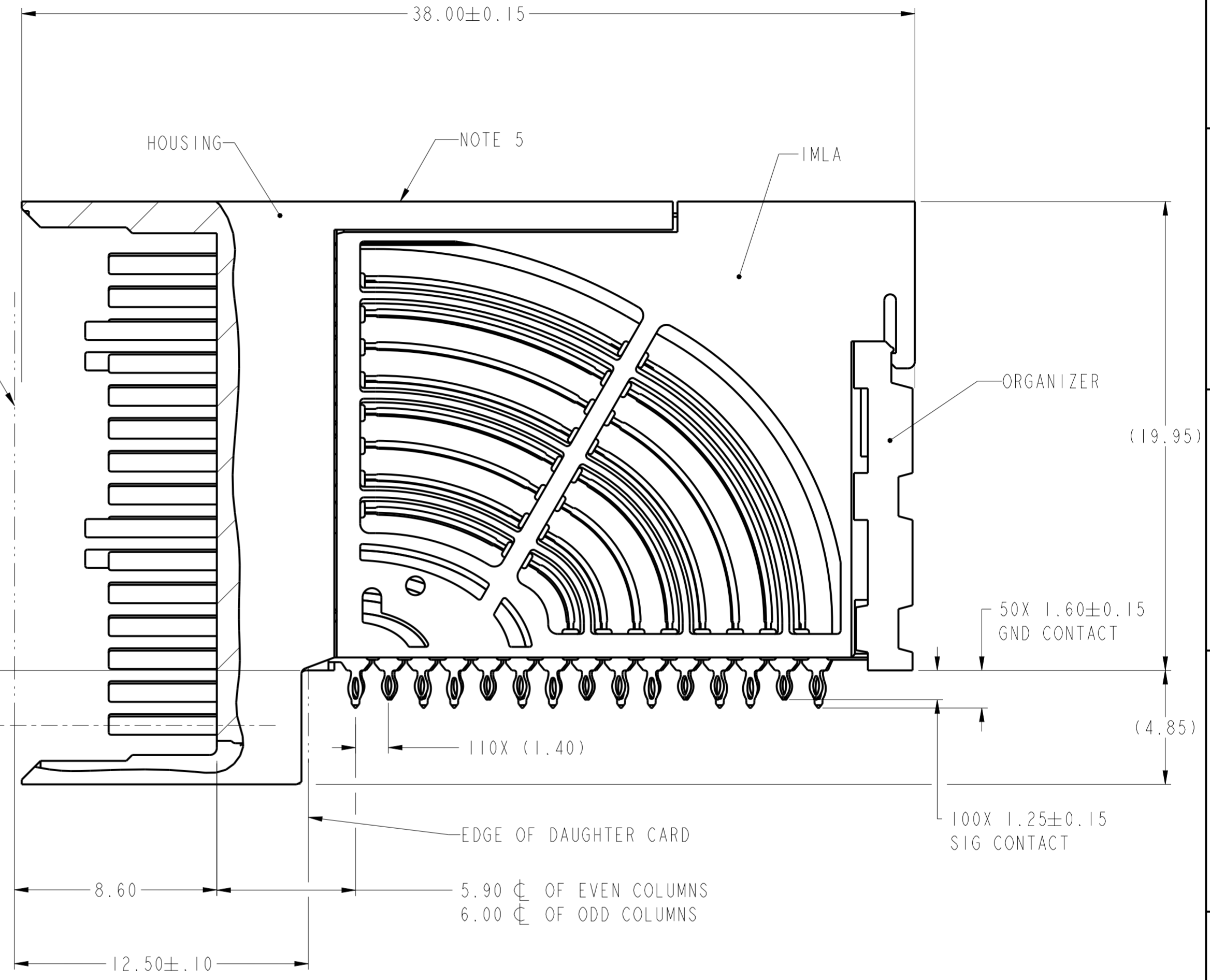
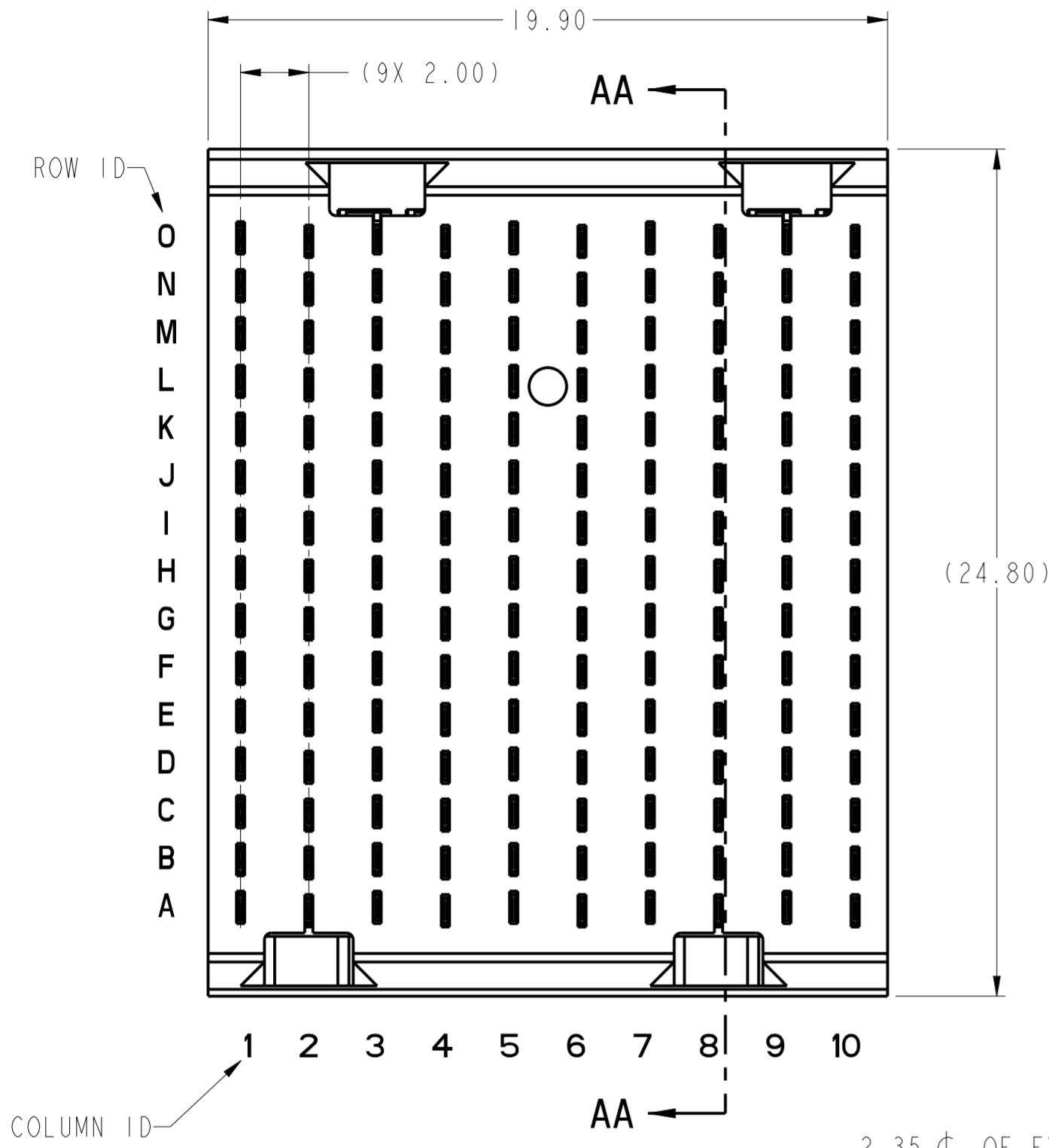

SECTION AA-AA

2.35 ϕ OF EVEN COLUMNS
2.25 ϕ OF ODD COLUMNS

5.90 ϕ OF EVEN COLUMNS
6.00 ϕ OF ODD COLUMNS

spec ref	---	dr	S Paulgandian	2013/02/27	projection	MM	size	A2	scale	10:1				
tolerance std	ASME Y14.5M	eng	Art Lin	2017/06/06			ecn no	ELX-DG-26994-1	rel level	Released				
TOLERANCES UNLESS OTHERWISE SPECIFIED		chr	Stone Li	2017/06/08			product family	AirMax VSe						
surface	linear	0.X	±.3	0.XX			±.15	0.XXX		±.050	Amphenol FCI	title	AirMax VSe R.A. HEADER	dwg no
	angular	0°	±2°	appr	Heaven Cen	2017/06/08	cat. no.		Product - Customer Draw	sheet 1 of 3				

PDS: Rev :D

STATUS: Released

Printed: 8 Jun 12, 2017

Amphenol FCI

© 2016 APCI

DESCRIPTION	DIM "D"	DIM "E"	DIM "F"
2-20MM MODULES PLACED END TO END	2.0	19.90 2X	20.00
1-20MM MODULE & 1-22MM MODULE PLACE END TO END	3.0	19.90 1X & 21.90 1X	21.00

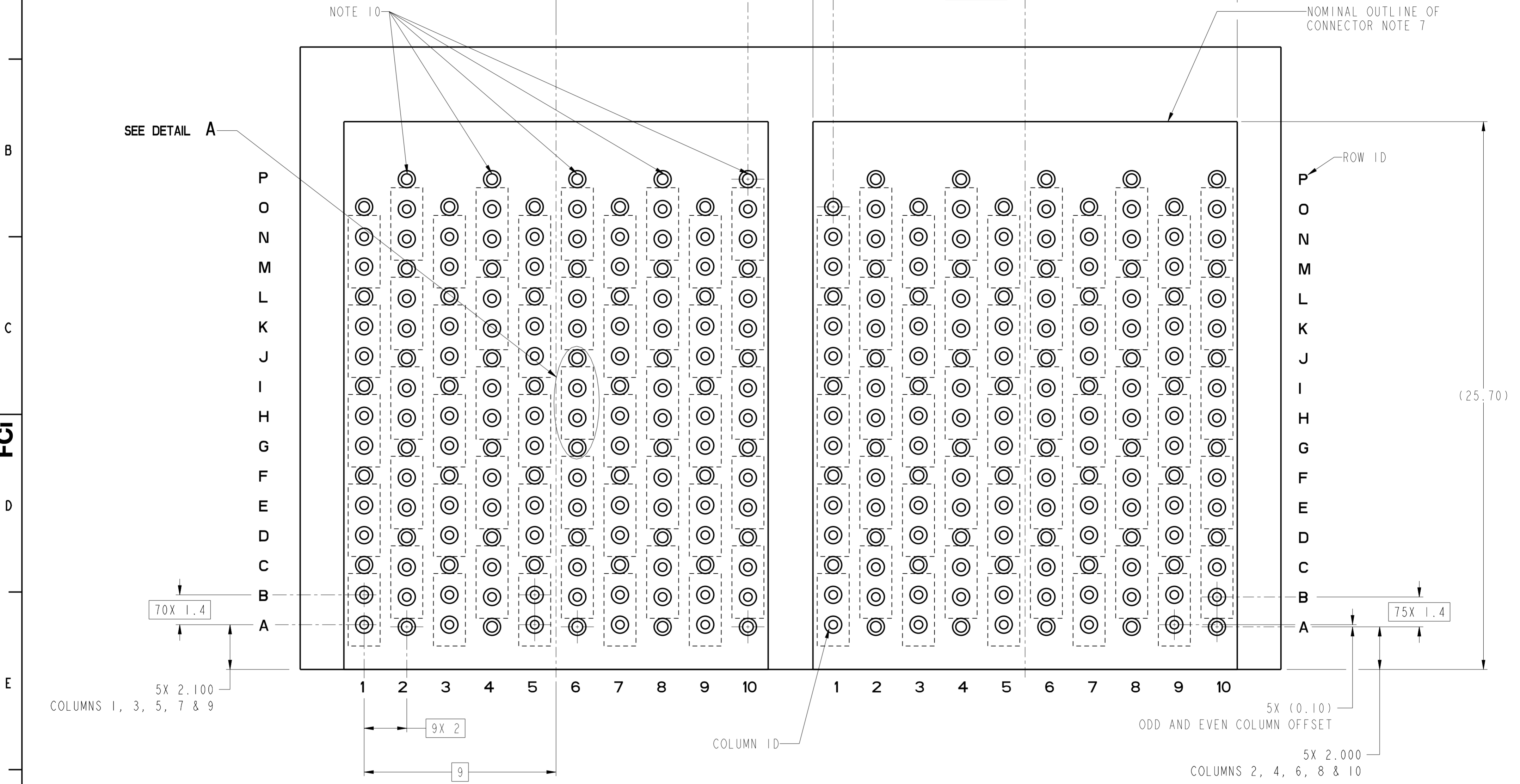

RECOMMENDED PCB LAYOUT
FOR DIFFERENTIAL APPLICATIONS
COMPONENT SIDE
(TWO ADJACENT FOOTPRINTS SHOWN)
NOTES 8 & 12
SCALE 8:1

spec ref	---	dr	S Paulgandian	2013/02/27	projection	MM	size	A2	scale	8:1
tolerance std	ASME Y14.5M	eng	Art Lin	2017/06/06			ecn no	ELX-DG-26994-1	rel level	Released
TOLERANCES UNLESS OTHERWISE SPECIFIED		chr	Stone Li	2017/06/08			product family	AirMax VSe		
surface	✓	appr	Heaven Cen	2017/06/08	Amphenol FCI		AirMax VSe R.A. HEADER		cat. no.	10124474
	linear			0.X	±.3	Product - Customer Drw		sheet 2 of 3		
				0.XX	±.15					
				0.XXX	±.050					
	angular			0°	±2°					

Amphenol FCI

© 2016 APCI

PRODUCT NUMBER	PRESS-FIT TAIL PLATING TYPE
10124474-101	TIN/LEAD ALLOY OVER NICKEL
10124474-101LF	TIN OVER NICKEL (LEAD FREE)
10124474-102LF	TIN OVER NICKEL (LEAD FREE) ENHANCED VERSION

- 1 - CONNECTOR MATERIALS:
HOUSING: HIGH TEMP THERMOPLASTIC, NATURAL, UL94-V0
IMLA PLASTIC: HIGH TEMP THERMOPLASTIC, BLACK, UL94-V0
CONTACT: COPPER ALLOY
ORGANIZER: HIGH TEMP THERMOPLASTIC, NATURAL, UL94-V0
- 2 - CONTACT PLATING:
SEPARABLE INTERFACE:
PERFORMANCE-BASED PLATING, QUALIFIED TO MEET THE REQUIREMENTS OF FCI PRODUCT SPECIFICATION GS-12-0956 INCLUDING TELCORDIA GR-1217-CORE (NOVEMBER 1995) CENTRAL OFFICE TEST SEQUENCE
- PRESS-FIT TAILS: SEE TABLE
- 3 - PRODUCT SPECIFICATION: GS-12-0956
- 4 - APPLICATION SPECIFICATION: GS-20-0305
- 5 - PRODUCT MARKING, (PROTOTYPE, PART NUMBER & LOT CODE), ON THIS SURFACE.
- 6 - POSITIONS "F" AND "L" OF ODD NUMBERED COLUMNS AND POSITIONS "G" AND "M" OF EVEN NUMBERED COLUMNS CORRESPOND TO EARLY MATE HEADER PINS.
- 7 - CONNECTOR OUTLINE MAY BE SCREEN PRINTED ONTO CUSTOMER PCB TO BE USED AS A GUIDE FOR CONNECTOR PLACEMENT.
- 8 - REFER TO CUSTOMER DRAWING 10104444 FOR INFORMATION ON PCB HOLE DIAMETERS AND PLATING OPTIONS
- 9 - LEAD FREE PRODUCT MEETS THE EUROPEAN UNION DIRECTIVES & OTHER COUNTRY REGULATIONS AS DESCRIBED IN GS-22-008
- 10 - THESE OUTER VIAS (P) ARE OPTIONAL. WHILE NO CONNECTOR EONS ARE PRESSED INTO THESE HOLES WE RECOMMEND (Ø0.500) FINISHED HOLES AT THESE LOCATIONS TO PROVIDE GROUND SYMMETRY THROUGH THE PCB.
- 11 - PACKAGING MEETS GS-14-920 LEAD FREE LABELING SPECIFICATION.
- 12 - GROUND CONTACTS (C, F, I, L, & O IN ODD COLUMNS AND A, D, G, J, & M IN EVEN COLUMNS) REQUIRE (Ø0.50) FINISHED HOLES. SIGNAL LOCATIONS REQUIRE (Ø0.40) FINISHED HOLES

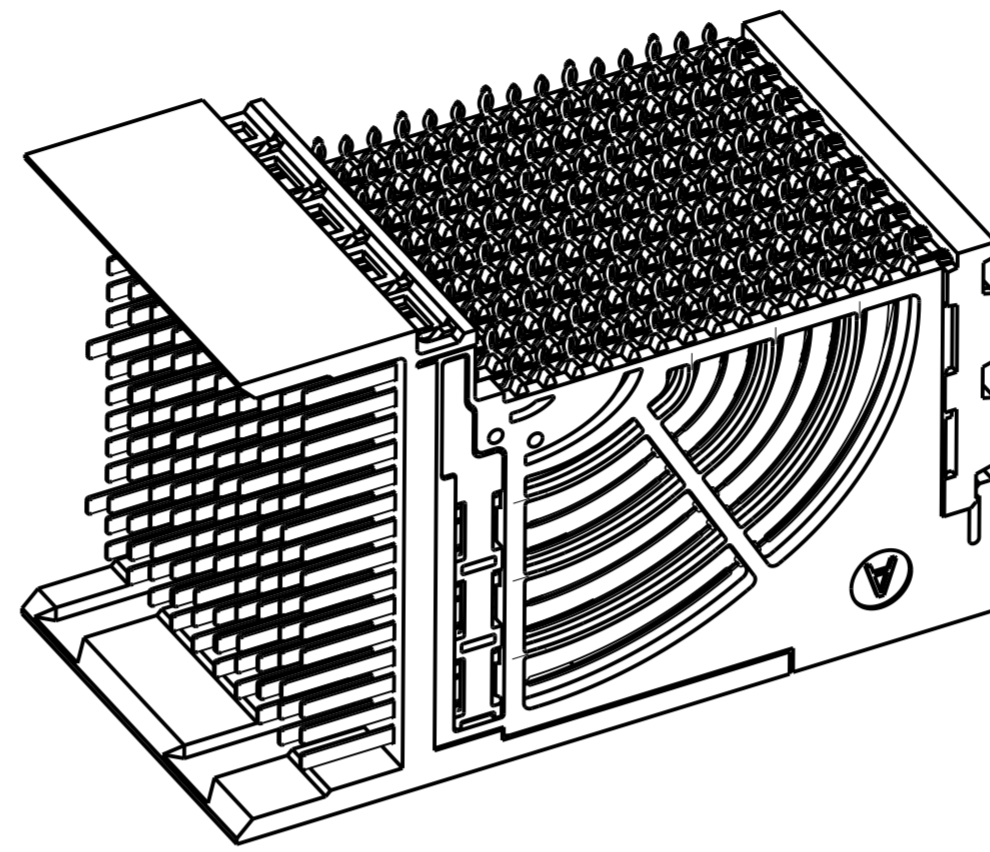

10124474-101 OR 101LF

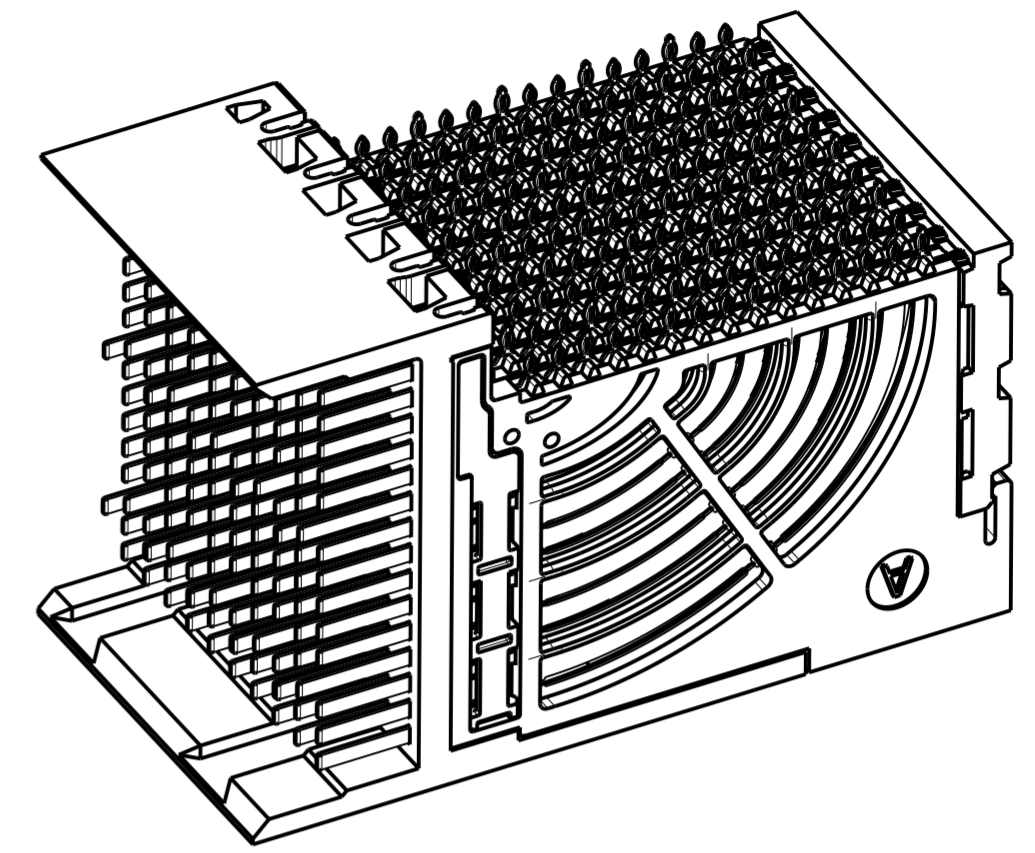

10124474-102LF

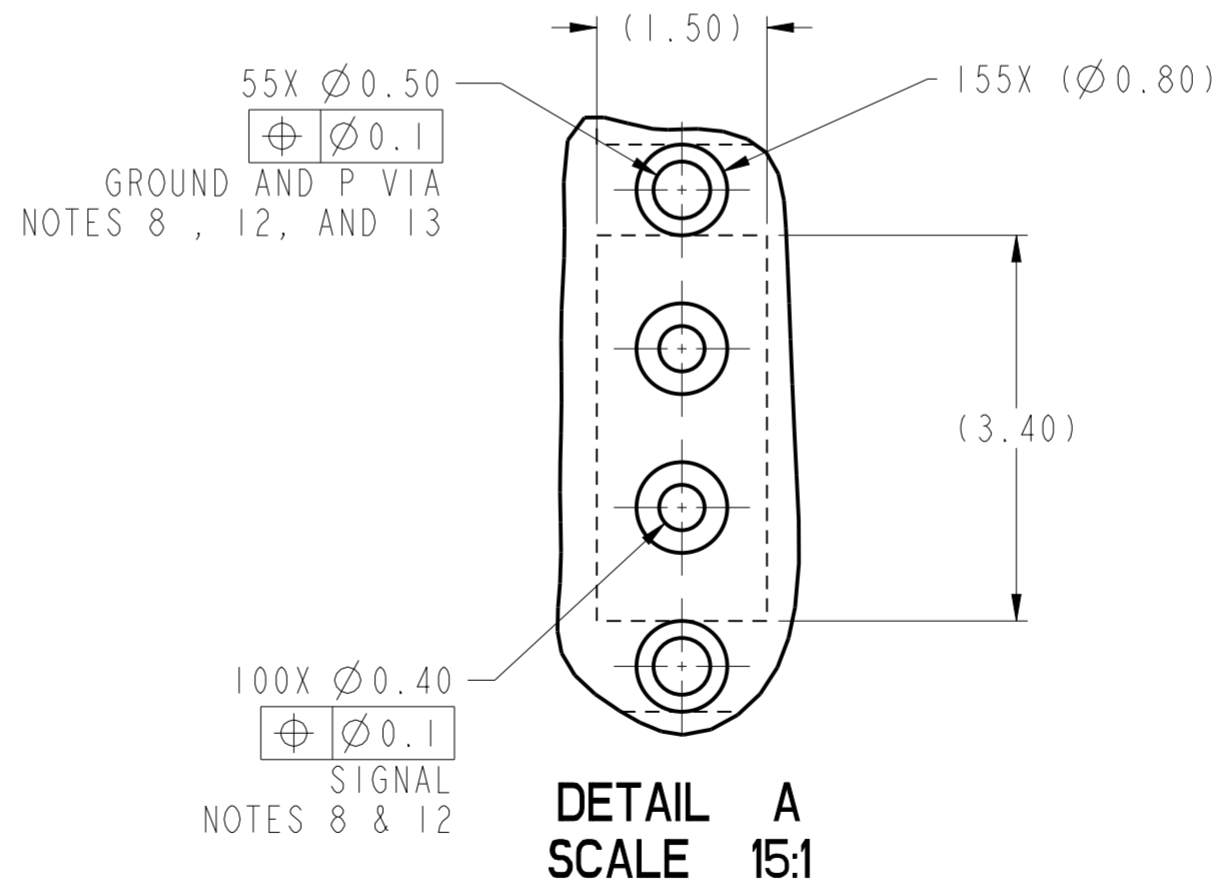

spec ref	---	dr	S Paulgandian	2013/02/27	projection	MM	size	A2	scale	10:1		
tolerance std	ASME Y14.5M	eng	Art Lin	2017/06/06			ecn no	ELX-DG-26994-1	rel level	Released		
TOLERANCES UNLESS OTHERWISE SPECIFIED		chr	Stone Li	2017/06/08			product family	AirMax VSe		rel level	Released	
surface	linear	0.X	±.3		Amphenol FCI		AirMax VSe R.A. HEADER		dwg no	10124474	rev	D
		0.XX	±.15		Ass'y, 5Pair, 150pos, 10IMLA, SPF, 2 Wall		cat. no.	Product - Customer Drw	sheet 3 of 3			
	angular	0°	±2°									



Компания «ЭлектроПласт» предлагает заключение долгосрочных отношений при поставках импортных электронных компонентов на взаимовыгодных условиях!

Наши преимущества:

- Оперативные поставки широкого спектра электронных компонентов отечественного и импортного производства напрямую от производителей и с крупнейших мировых складов;
- Поставка более 17-ти миллионов наименований электронных компонентов;
- Поставка сложных, дефицитных, либо снятых с производства позиций;
- Оперативные сроки поставки под заказ (от 5 рабочих дней);
- Экспресс доставка в любую точку России;
- Техническая поддержка проекта, помощь в подборе аналогов, поставка прототипов;
- Система менеджмента качества сертифицирована по Международному стандарту ISO 9001;
- Лицензия ФСБ на осуществление работ с использованием сведений, составляющих государственную тайну;
- Поставка специализированных компонентов (Xilinx, Altera, Analog Devices, Intersil, Interpoint, Microsemi, Aeroflex, Peregrine, Syfer, Eurofarad, Texas Instrument, Miteq, Cobham, E2V, MA-COM, Hittite, Mini-Circuits, General Dynamics и др.);

Помимо этого, одним из направлений компании «ЭлектроПласт» является направление «Источники питания». Мы предлагаем Вам помощь Конструкторского отдела:

- Подбор оптимального решения, техническое обоснование при выборе компонента;
- Подбор аналогов;
- Консультации по применению компонента;
- Поставка образцов и прототипов;
- Техническая поддержка проекта;
- Защита от снятия компонента с производства.



Как с нами связаться

Телефон: 8 (812) 309 58 32 (многоканальный)

Факс: 8 (812) 320-02-42

Электронная почта: org@eplast1.ru

Адрес: 198099, г. Санкт-Петербург, ул. Калинина, дом 2, корпус 4, литера А.