

DC-DC Converter DATA Sheet

MYBEB00520AZT

Feature:

- 1/8th Brick type
- Vin 36Vdc-75Vdc
- Vout 5Vdc
- I out 20A dc
- 100W

1. Application

This specification applies to DC-DC Converter MYBEB00520AZT for telecommunication / data-communication equipment. For any other application, please contact us before using this product.



2. Appearance, Dimensions
MYBEB00520AZT

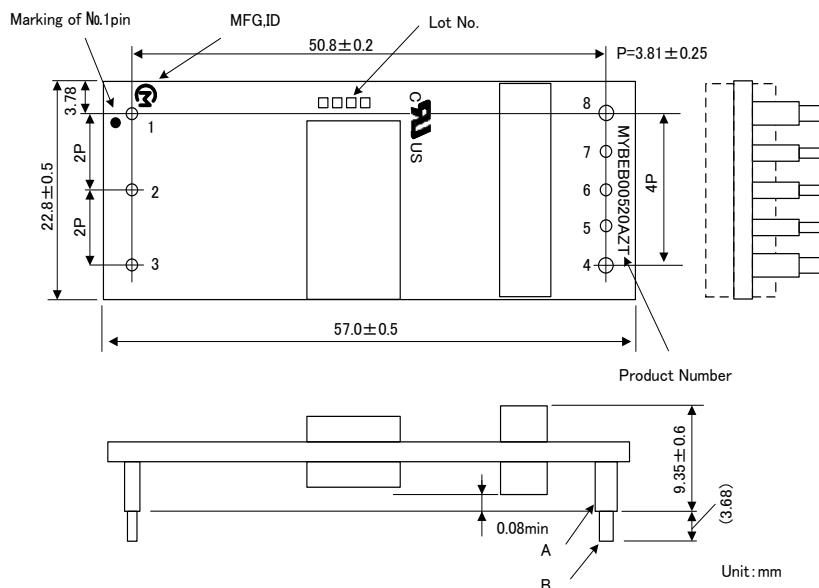

Marking (1) MFG ID

(2) ①②③④

- Lot No.
- ① Production factory Mark
 - ② Production Year
 - ③ Production Month
 - ④ Product Modification number (No marking now)

(3) Product Number
MYBEB00520AZT

Pin No.	A : Stand-off	B : Board insertion portion
1,2,3,5,6,7	φ 1.57 ± 0.1	φ 1.02 ± 0.1
4,8	φ 2.36 ± 0.1	φ 1.57 ± 0.1

Note:

1. This datasheet is downloaded from the website of Murata Manufacturing co., ltd. Therefore, it's specifications are subject to change or our products in it may be discontinued without advance notice. Please check with our sales representatives or product engineers before ordering.
2. This datasheet has only typical specifications because there is no space for detailed specifications. Therefore, please approve our product specifications or transact the approval sheet for product specifications before ordering.

3. Pin Number and Function

Pin No.	Symbol	Function
1	+Vin	(+)Input
2	RC	Remote ON/OFF
3	-Vin	(-)Input
4	-Vout	(-)Output
5	NC	
6	NC	
7	NC	
8	+Vout	(+)Output

4. Block Diagram

4.1. Entire Product

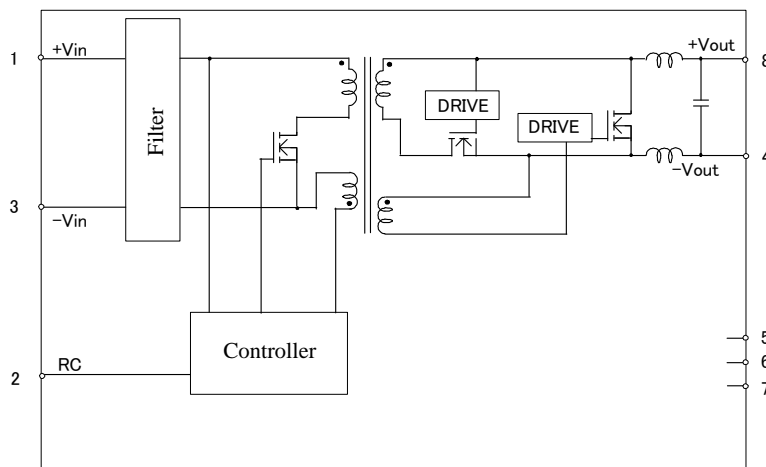

⚠ Note:

1. This datasheet is downloaded from the website of Murata Manufacturing co., ltd. Therefore, it's specifications are subject to change or our products in it may be discontinued without advance notice. Please check with our sales representatives or product engineers before ordering.
2. This datasheet has only typical specifications because there is no space for detailed specifications. Therefore, please approve our product specifications or transact the approval sheet for product specifications before ordering.

5. Environmental Conditions

- 5.1. Operating Temperature Range -40°C ~ +85°C (Temperature gradient $\leq 10^{\circ}\text{C}/\text{H}$)
- 5.2. Operating Humidity Range Relative Humidity 20% ~ 85% (No water condenses.)
& Absolute Humidity 0.044kg/kg D.A.max(at 40°C)
- 5.3. Storage Temperature Range -40°C ~ +85°C(Temperature gradient $\leq 25^{\circ}\text{C}/\text{H}$)
- 5.4. Storage Humidity Range 10% ~ 85%(No water condenses.)

6. Absolute Rating

Item		Unit	Absolute Rating	Remarks
Minimum Input Voltage		V	0	
Maximum Input Voltage	Continuous	V	75	
	100ms	V	100	
ON/OFF pin Control Voltage	Maximum	V	10	
	Minimum	V	0	

No voltage, no matter how instantaneous, shall be applied beyond the absolute maximum voltage rating to this product. If you apply any voltage over this limit the product characteristics will deteriorate or the product itself will be destroyed. Even though it may continue operating for a while after the over-voltage event, its life will likely be shortened significantly. Reliability and life of the module may degrade similarly if the maximum operating voltage rating is continuously exceeded. This product is designed to operate within the maximum operating voltage rating specification.

Note:

1. This datasheet is downloaded from the website of Murata Manufacturing co., ltd. Therefore, it's specifications are subject to change or our products in it may be discontinued without advance notice. Please check with our sales representatives or product engineers before ordering.
2. This datasheet has only typical specifications because there is no space for detailed specifications. Therefore, please approve our product specifications or transact the approval sheet for product specifications before ordering.

7. Characteristics

7.1. Electrical Characteristics (Ta=25°C with temperature derated.)

7.1.1. General Characteristics

Item	Symbol	Condition	Value			Unit
			Min.	Typ.	Max.	
Input Voltage	Vin		36	48	75	V
Turn-on Input Voltage	Von	Vin=increasing	32	-	36	V
Input Voltage difference of Turn-on and Turn-off	Von_hys		2.0	-	-	V
Output Voltage	Vout	Vin =Min~Max Iout=Min~Max	4.85	5.0	5.15	V
Output Current	Iout	with Temperature derated	0	-	20	A
Ripple Noise Voltage	Vripl	Refer to 10. Test Circuit	-	-	90	mV(p_p)
Ripple Noise Voltage	Vnoise		-	-	100	mV(p_p)
Efficiency ※	η	Vin =48.0V Iout=20.0A Ta=25°C	-	93.0	-	%
ON/OFF pin Control Voltage	Von		0	-	0.7	V
	Voff		2	-	10	V
Setting point of Over Current Protection	OCP	Vin =Min~Max	20.6	-	-	A
Setting point of Over Voltage Protection	OVP	Vin =Min~Max	6.0	-	-	V
Setting point of Low Voltage Protection	LVP	Vin =Min~Max	-	-	4.5	V
Setting point of Temperature Protection	OTP	Vin =Min~Max Temp. detect point: near main SW.	-	140	-	°C
Start up Delay Time	ts	Vin =Min~Max Iout=Min~Max Vin connection to Vout × 90%	-	-	250	ms
Input to Output Isolation Voltage	Vdc_io	DC for one minute leak current 1mA max	1500	-	-	V

⚠ Note:

1. This datasheet is downloaded from the website of Murata Manufacturing co., Ltd. Therefore, it's specifications are subject to change or our products in it may be discontinued without advance notice. Please check with our sales representatives or product engineers before ordering.
2. This datasheet has only typical specifications because there is no space for detailed specifications. Therefore, please approve our product specifications or transact the approval sheet for product specifications before ordering.

Item	Value
Protection	①If output is shorted or output voltage is over the value specified in OVP , DC-DC converter go into latch-up mode. DC-DC converter restart by input voltage kept less than 5V, more than 1 sec or Remote On/off Control. ②If DC-DC converter is heated abnormally , it will shut down. After it is cooled down , DC-DC converter will automatically restart.
Noise (Radiation, Conduction)	In accordance with VCCI Class A

※ The efficiency is measured in the following conditions in production process.



Caution

The above electrical characteristics are guaranteed in the condition that the impedance of the input power supply is sufficiently low as shown in section 8.

Connecting an input inductance or using an input power supply with output inductance may cause an unstable operation of this product. Please check the proper operation of this product with the peripheral circuits on your product.

⚠ Note:

1. This datasheet is downloaded from the website of Murata Manufacturing co., ltd. Therefore, it's specifications are subject to change or our products in it may be discontinued without advance notice. Please check with our sales representatives or product engineers before ordering.
2. This datasheet has only typical specifications because there is no space for detailed specifications. Therefore, please approve our product specifications or transact the approval sheet for product specifications before ordering.

7.2. Operation Information

7.2.1. Reset Condition

In order to reset all function, the input Voltage is set under 5V for Min.1 second.

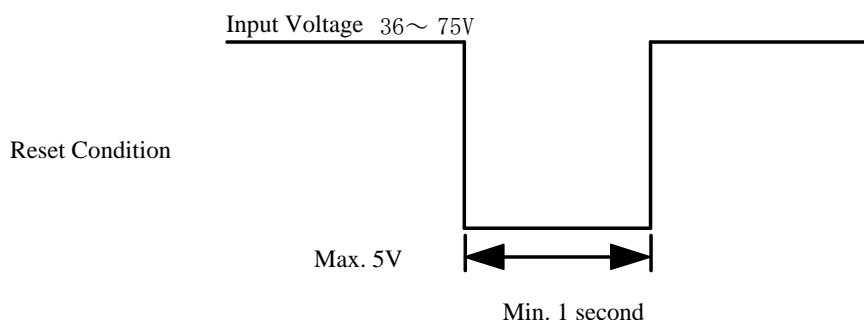

7.2.2. Low Voltage Protection

Output halts in latch-up mode after 150msec(typ) mask time while output current is more than the value of Over Current Protection specified in 9.1.section with over loaded condition.

It is reset that input voltage is kept 5V or less for 1sec or more or Remote On/off Control is used.

7.2.3. Over Voltage Protection

Output halts in latch-up mode after 0.5msec(typ) mask time while Output Voltage is over the value of over voltage protection specified in 9.1. clause with failure of controller circuit.

Output will re-start after input turns off for Min. 1 second with input voltage less than 5V.

Output voltage might exceed the point at over voltage protection under the specific condition of transient change of input voltage or output load, in this condition over voltage protection wait its start until the mask time.

It is recommended to evaluate your appliance installed with DC-DC converter.

7.2.4. Over Temperature Protection

The temperature of primary main switch on the isolated DC-DC converter is detected by thermister.

If DC-DC converter is heated abnormally , it will shut down over 140°Ctyp. .

After it is cooled down, DC-DC converter will automatically restart.

7.2.5. Remote On/Off Control

Start and halt is possible with a control signal.

While the control signal stops output from DC-DC converter, alarm output does not send any signal.

Start : RC is open or connected to-Vin.

Stop : RC is connected to +Vin.

⚠ Note:

1. This datasheet is downloaded from the website of Murata Manufacturing co., ltd. Therefore, it's specifications are subject to change or our products in it may be discontinued without advance notice. Please check with our sales representatives or product engineers before ordering.
2. This datasheet has only typical specifications because there is no space for detailed specifications. Therefore, please approve our product specifications or transact the approval sheet for product specifications before ordering.

8. Test Circuit

In the following test circuit, the measured values should meet those of clause 9.

8.1. General Measure Circuit

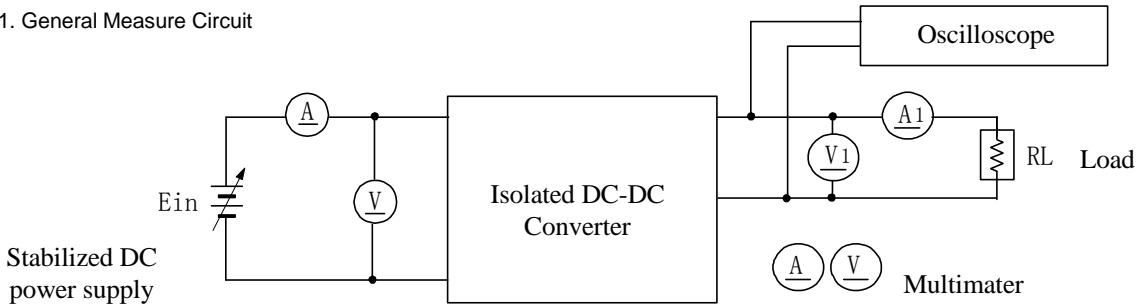

8.1.1. Output Ripple & Noise

Coaxial cable : 1.5D-2V, (JISC3501), Length is 1.5m

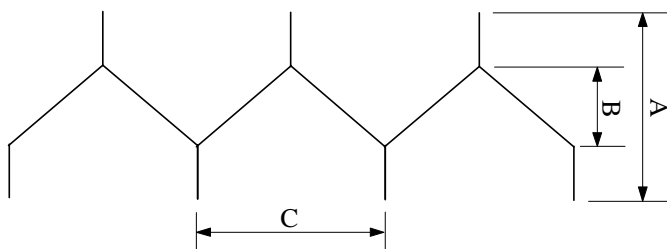
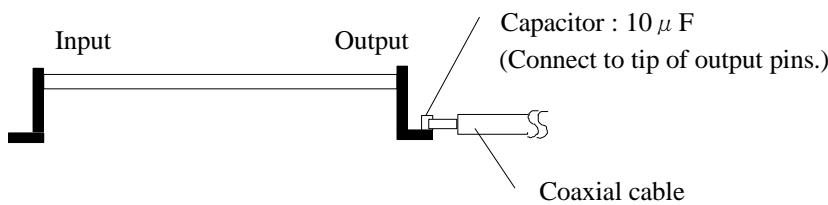
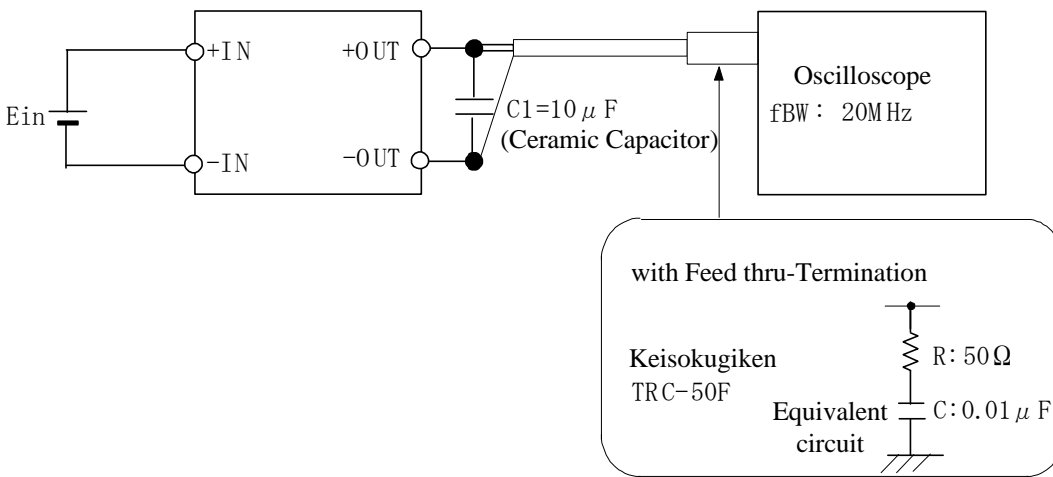

Note:

1. This datasheet is downloaded from the website of Murata Manufacturing co., ltd. Therefore, it's specifications are subject to change or our products in it may be discontinued without advance notice. Please check with our sales representatives or product engineers before ordering.
2. This datasheet has only typical specifications because there is no space for detailed specifications. Therefore, please approve our product specifications or transact the approval sheet for product specifications before ordering.

8.1.2. Radiation · Conduction Noise

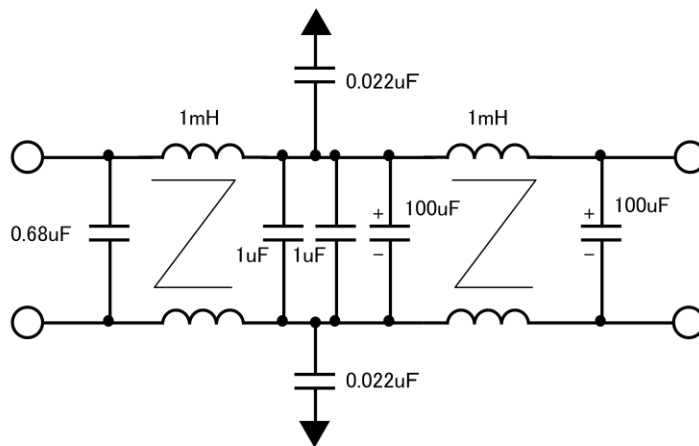

Measurement at Radiation Noise, Conductive Noise, Output ripple & Noise.

Please measure Radiation Noise, Conductive Noise and Output ripple & Noise with conforming to the Test Circuit in clause 10
Otherwise the noise might not meet the specified values.

9. Mechanical Tests

9.1. Vibration

Vibration Frequency : 10~55Hz

Amplitude : 1.5mm max

10 to 55Hz, 1.5mm amplitude, 1 hour for each of X,Y,Z directions.

No damage in appearance and no deviation from electrical characteristics (section 7).

9.2. Mechanical Shock

20G, 1 time for each X,Y,Z directions.

No damage in appearance and no deviation from electrical characteristics (section 7).

9.3. Soldering Heat Resistance

Immerse the tips of lead pins, which are to be mounted on a mother board, in a solder bath of 260±5deg.C for 3sec.

Then tested products are left for 2 hours.

No damage in appearance and no deviation from electrical characteristics (section 7).

9.4. Pin Strength

Fasten the body of DC-DC Converter and pull the lead pin gradually in a radial direction with

5.0N load, keep the load for 5 seconds. The body should not be damaged thereafter.

9.5. Solderability of Pins

The lead pins will be immersed in the isopropyl alcohol (JIS-K-1522) with Rosin (JIS-K-5902) solution (the concentration of Rosin will be allowed 10wt%~35wt%, and normally approx. 25wt% will be used unless otherwise any specific required.). Then the lead pins up to 1 to 1.5mm from the product substrate will be immersed in the Sn-3Ag-0.5Cu solder melted in the temperature of 250±5°C and pulled up after 5±1 seconds. The solder will adhere to over 75% of the immersed area.

⚠ Note:

1. This datasheet is downloaded from the website of Murata Manufacturing co., ltd. Therefore, it's specifications are subject to change or our products in it may be discontinued without advance notice. Please check with our sales representatives or product engineers before ordering.
2. This datasheet has only typical specifications because there is no space for detailed specifications. Therefore, please approve our product specifications or transact the approval sheet for product specifications before ordering.

10. Environmental Tests

10.1. Humidity Test

Subjected to a temperature $40^{\circ}\text{C}\pm 2^{\circ}\text{C}$ with 90~95% for 100 hours.

Return to room temperature (25°C) for 2 hours and measure. The initial values in section 7 should be met. (JIS-C-0022)

10.2. Thermal Cycle Test

Subjected to 5 cycles of the following condition.

Placed in room temperature (25°C) for 2 hours and are measured.

The initial values in section 7 should be met.

Step	Condition	Time
1	$-40^{\circ}\text{C}\pm 3^{\circ}\text{C}$	30 minutes
2	Room Temp.	5~10 minutes
3	$+85^{\circ}\text{C}\pm 3^{\circ}\text{C}$	30 minutes
4	Room Temp.	5~10 minutes

⚠ Note:

1. This datasheet is downloaded from the website of Murata Manufacturing co., ltd. Therefore, it's specifications are subject to change or our products in it may be discontinued without advance notice. Please check with our sales representatives or product engineers before ordering.
2. This datasheet has only typical specifications because there is no space for detailed specifications. Therefore, please approve our product specifications or transact the approval sheet for product specifications before ordering.

11. Packaging information

11.1 Packing form

- ① Like the below figure, put the products on a conductive mat. (1 row \times 6 column) (See Fig.1)
- ② Pile these conductive mats and pack maximum 4 units.

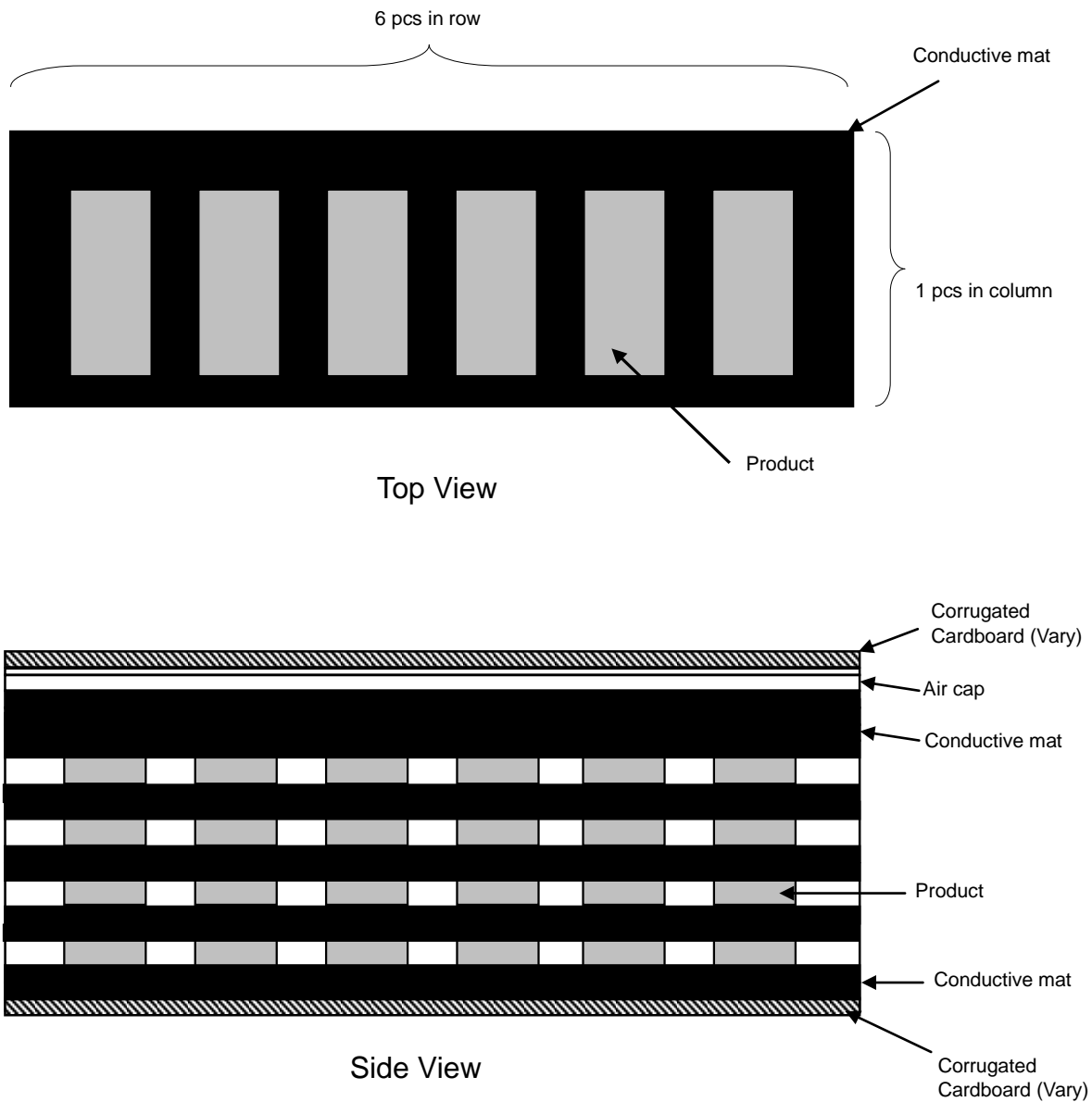
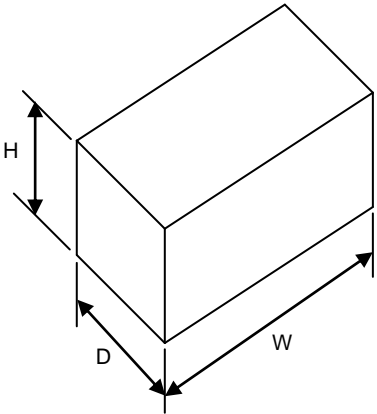

Fig.1

Note:

1. This datasheet is downloaded from the website of Murata Manufacturing co., ltd. Therefore, it's specifications are subject to change or our products in it may be discontinued without advance notice. Please check with our sales representatives or product engineers before ordering.
2. This datasheet has only typical specifications because there is no space for detailed specifications. Therefore, please approve our product specifications or transact the approval sheet for product specifications before ordering.

11.2 Packaging form

Item	Specification
Packaging form typical classification	Box
Dimensions of packaging box(typ.)	 <p> $W = 245 \text{ (mm)}$ $D = 78 \text{ (mm)}$ $H = 104 \text{ (mm)}$ </p>
Maximum number in a box	24(p c s)
Weight of one product	20 (g)
Remark	<ul style="list-style-type: none"> •The number of contained products may not reach to the maximum number.

- Products must not scattered in the box or product pins must not be bended in transportation.

※Marking on the box

1. MURATA Parts Number
2. Quantity
3. Inspection No.
4. CE Mark
5. ROHS—Y< * >

[ROHS-Y<*>] is shown on a package label of RoHS compliant products.

①<*> is revision code of RoHS Directive like A>B>C...

The regulation shown with alphabet of * refers to an other attached document [Indication Express for Regulation about Hazardous Substance of Use Limitation]

⚠ Note:

1. This datasheet is downloaded from the website of Murata Manufacturing co., ltd. Therefore, it' s specifications are subject to change or our products in it may be discontinued without advance notice. Please check with our sales representatives or product engineers before ordering.
2. This datasheet has only typical specifications because there is no space for detailed specifications. Therefore, please approve our product specifications or transact the approval sheet for product specifications before ordering.

12. Production factory

Wakura Murata Manufacturing Co., Ltd.
Murata Manufacturing (Thailand), Ltd.

13. Reference data

13.1. Power derating

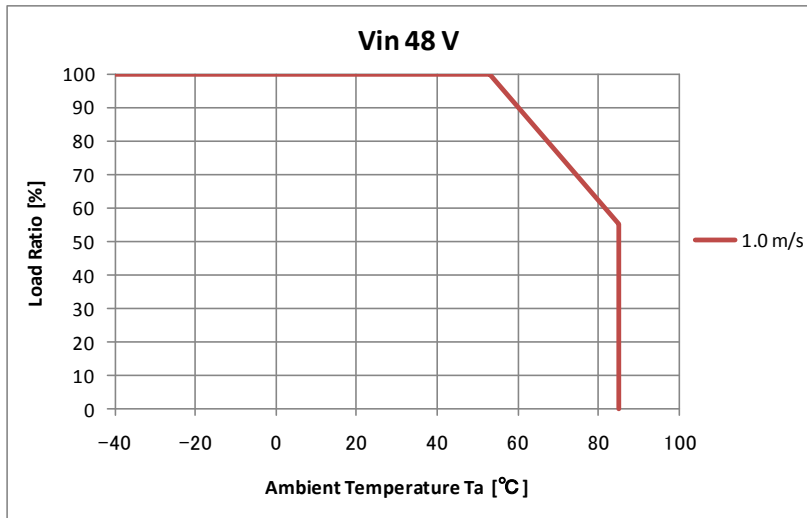

※Reference only : evaluation board for temperature measurement (glass-epxy 2 layer , 100*180*1.6mm)

[Note]

We would like to emphasize the data is based on our experimental measurement.
Please measure ambient temperature around a DC-DC Converter on your applications.

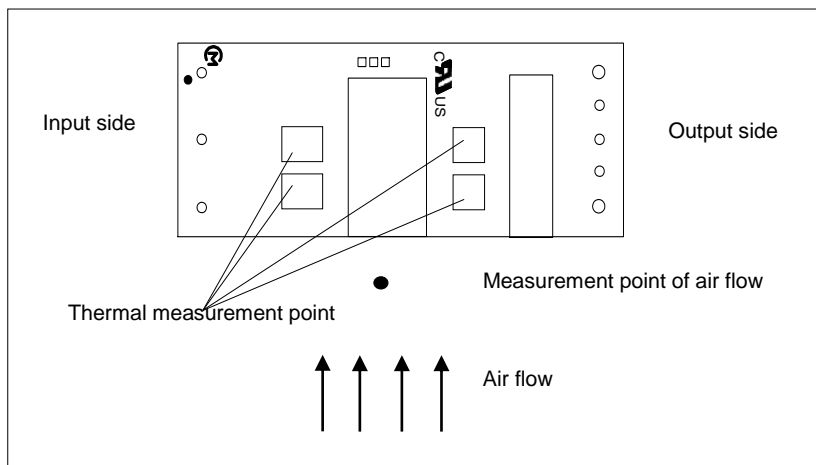

⚠ Note:

1. This datasheet is downloaded from the website of Murata Manufacturing co., ltd. Therefore, it's specifications are subject to change or our products in it may be discontinued without advance notice. Please check with our sales representatives or product engineers before ordering.
2. This datasheet has only typical specifications because there is no space for detailed specifications. Therefore, please approve our product specifications or transact the approval sheet for product specifications before ordering.

13.2 Efficiency

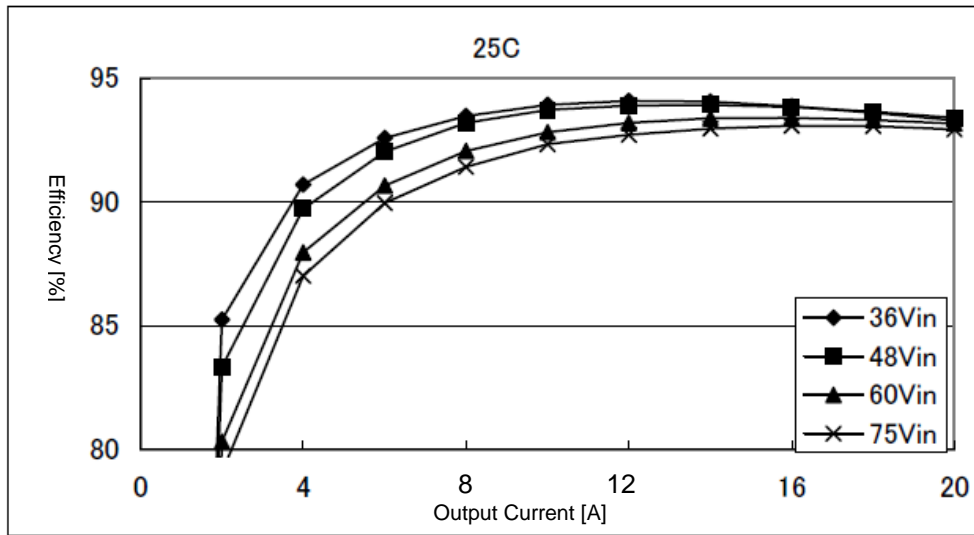

13.3 Ripple Noise

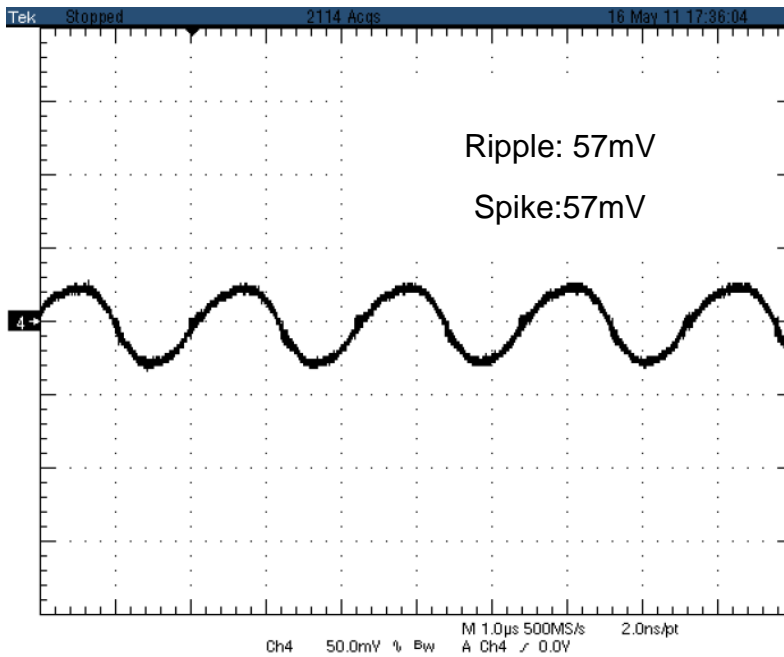

Note:

1. This datasheet is downloaded from the website of Murata Manufacturing co., ltd. Therefore, it's specifications are subject to change or our products in it may be discontinued without advance notice. Please check with our sales representatives or product engineers before ordering.
2. This datasheet has only typical specifications because there is no space for detailed specifications. Therefore, please approve our product specifications or transact the approval sheet for product specifications before ordering.

13.4. Startup waveform

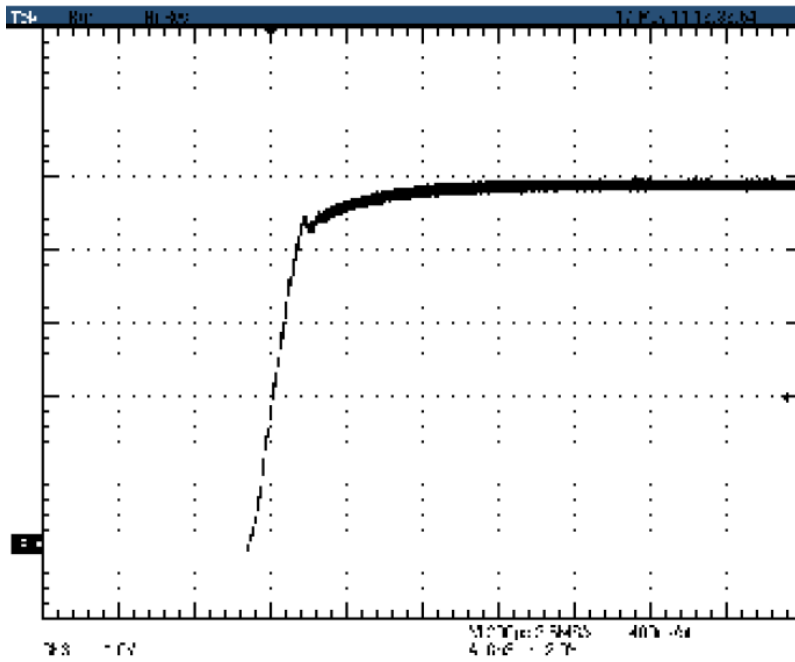

13.5. Startup delay

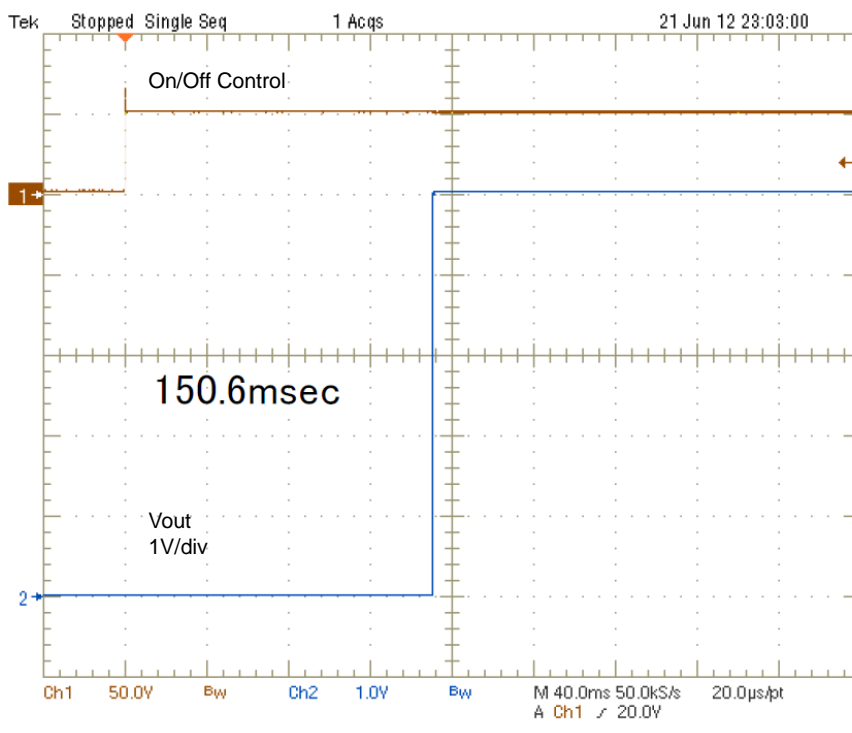

Note:

1. This datasheet is downloaded from the website of Murata Manufacturing co., ltd. Therefore, it's specifications are subject to change or our products in it may be discontinued without advance notice. Please check with our sales representatives or product engineers before ordering.
2. This datasheet has only typical specifications because there is no space for detailed specifications. Therefore, please approve our product specifications or transact the approval sheet for product specifications before ordering.

14. Notice

14.1. Soldering

14.1.1. Flux

Please solder the product with Rosin Flux, which contains chlorine 0.2wt% or less.

Please do NOT use acid flux or water-soluble flux, which could corrode metals and glass of the product.

14.1.2. Solder

Lead Free Solder

Please use solder Sn-3Ag-0.5Cu

14.1.3 Recommended soldering Conditions

Please solder under the following condition.

① Flow Solder

Preheating : 120±10°C 60~120 seconds

Solder temperature : 250°C +0°C/-5°C

Soldering time : 10 seconds max

② Condition of iron Soldering

Preheating : 120±10°C 30 minutes max

Iron temperature : 350°C max

Soldering time : 3 seconds max

14.2. Cleaning

14.2.1. Please clean this product to remove flux by using dip, boil, and vapor methods in isopropyl alcohol for up to 5 minutes.

Please inform us if you are to use aqueous or semi-aqueous cleaning or other methods.

Do not use ultrasonic cleaning because semiconductor device on this product maybe damaged by resonance.

14.2.2. After cleaning, please dry this product thoroughly.

If you touch the wet product, marking maybe erased or blurred.

Do not measure electrical characteristics, until this product gets dried enough.

14.2.3. If you don't clean this product with no-cleaning type flux, you must confirm fully in advance the reliability of this product.

14.3. Storage

14.3.1. Please store the products in room where the temperature/humidity is stable and direct sunlight cannot come in, and use the products within 6 months after delivery.

Please avoid damp and heat or such places where the temperature greatly changes, as water may condense on this product, and the quality of characteristics may be reduced, and/or be the solderability may be degraded.

If this product needs to be stored for a long time (more than 1 year), this product may be degraded in solderability and/or corroded. Please test the solderability of this product regularly.

14.3.2. Please do not store this product in the conditions such as a dusty place, a place exposed directly to sea breeze, or in an atmosphere containing corrosive gas (Cl₂, NH₃, SO₂, NO_x and so on).

⚠ Note:

1. This datasheet is downloaded from the website of Murata Manufacturing co., ltd. Therefore, it's specifications are subject to change or our products in it may be discontinued without advance notice. Please check with our sales representatives or product engineers before ordering.
2. This datasheet has only typical specifications because there is no space for detailed specifications. Therefore, please approve our product specifications or transact the approval sheet for product specifications before ordering.

14.4. Operational Environment and Operational Conditions

14.4.1. Operational Environment

This product is not water-, chemical- or corrosion-proof.

In order to prevent leakage of electricity and abnormal temperature rise of this product, do not use this product in the following conditions:

- (1) in an atmosphere containing corrosive gas (Cl₂, NH₃, SO₂, NO_X and so on)
- (2) in a dusty place
- (3) in a place exposed to direct sunlight
- (4) in such a place where water splashes or in such a humid place where water condenses
- (5) in a place exposed to sea breeze
- (6) in any other places similar to the above

14.4.2. Operational Conditions

Please use this product within specified values (power supply, temperature, input, output, load condition, and so on).

If not used within the specified values, defectiveness and deterioration of this product may be caused. Even if this product can endure the condition for short time, it may cause degradation of reliability.

It is recommended that a fuse is inserted in input line (Vin) to secure safety in any abnormality such as internal circuit of Isolated DC-DC Converter broken down.

Also please take care that the external voltage over output voltage of DC-DC Converter does not applies to output of this Isolated DC-DC Converter.

14.4.3. Note prior to use

Defectiveness and reliability degradation may be caused if high static electricity, over rated voltage or reverse voltage are applied to this product. Please be sure to avoid the followings:

- (1) over rating power supply, reverse power supply or inadequate connection of 0 V(DC)line
- (2) electrostatic discharge from production line and/or operator
- (3) electrified product from electrostatic induction

Please avoid an excessive mechanical shock.

If this product is dropped on the floor, etc., a crack to the core of inductors and monolithic ceramic capacitors may occur.

Please handle with care to avoid a strong shock to this product.

Do not give excessive mechanical stress to the product with your handling.

Do not bend this product much more than 0.1mm.

14.5. Transportation

If you transport the products, please pack them so that the package will not be damaged by mechanical vibration or mechanical shock, and please educate and guide a carrier to prevent rough handling.

If you transport the products to overseas (in particular, by sea), it is expected that the transportation environment will be the worst, so please pack the products, in the package designed on the consideration of mechanical strength, vibration-resistant and humidity-resistant.

The package of the products, which Murata sells in Japan, may not resist over sea transport.

Please consult us if you are to use the Murata package of the products sold in Japan for transport to overseas.

⚠ Note:

1. This datasheet is downloaded from the website of Murata Manufacturing co., ltd. Therefore, it's specifications are subject to change or our products in it may be discontinued without advance notice. Please check with our sales representatives or product engineers before ordering.
2. This datasheet has only typical specifications because there is no space for detailed specifications. Therefore, please approve our product specifications or transact the approval sheet for product specifications before ordering.

15. Notice

- 15.1. Be sure to provide an appropriate fail-safe function on your product to prevent a second damage that may be caused by the abnormal function or the failure of our product.
- 15.2. Please connect the input terminal by right polarity. If you mistake the connection, it may break the DC-DC converter. In the case of destruction of the DC-DC converter inside, a large input current may flow. Please add a diode and fuse as follows.

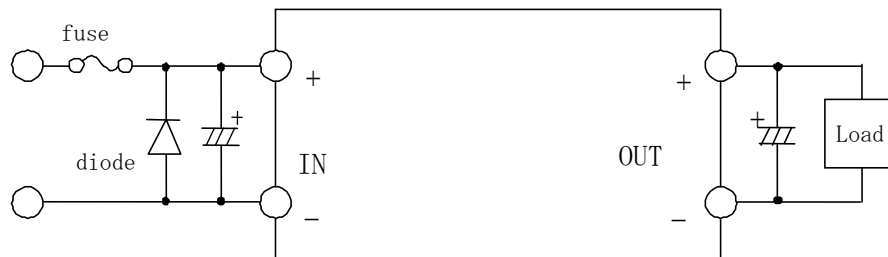

Rated Fuse Current : 6.3A

※Please select a diode and fuse after confirming the operation.

15.3. Applications

- (a) This product is designed and manufactured for the general applications such as computers, office appliances, communication equipment, measurement instruments, machine tools, factory equipment, audiovisual equipment and home appliances, etc.
- (b) Please contact us before using this product for the applications, which require high reliability, such as transportation equipment (aircraft, trains, vehicles, etc.), traffic lights equipment, disaster prevention/crime prevention equipment, etc.
- (c) Please do NOT use this product for the applications which require especially high reliability, such as aerospace equipment, undersea equipment, nuclear power plant control equipment, medical equipment, etc.



Note

1. Please make sure that your product has been evaluated and confirmed against your specifications when our product is mounted to your product.
2. All the items and parameters in this product specification have been prescribed on the premise that our product is used for the purpose, under the condition and in the environment agreed upon between you and us. You are requested not to use our product deviating from such agreement.
3. We consider it not appropriate to include other terms and conditions for transaction warranty in product specifications, drawings or other technical documents. Therefore, if your technical documents as above include such terms and conditions as warranty clause, product liability clause, or intellectual property infringement liability clause, we will not be able to accept such terms and conditions unless they are based on the governmental regulation or they are stated in a separate contract agreement.

⚠ Note:

1. This datasheet is downloaded from the website of Murata Manufacturing co., Ltd. Therefore, it's specifications are subject to change or our products in it may be discontinued without advance notice. Please check with our sales representatives or product engineers before ordering.
2. This datasheet has only typical specifications because there is no space for detailed specifications. Therefore, please approve our product specifications or transact the approval sheet for product specifications before ordering.



Компания «ЭлектроПласт» предлагает заключение долгосрочных отношений при поставках импортных электронных компонентов на взаимовыгодных условиях!

Наши преимущества:

- Оперативные поставки широкого спектра электронных компонентов отечественного и импортного производства напрямую от производителей и с крупнейших мировых складов;
- Поставка более 17-ти миллионов наименований электронных компонентов;
- Поставка сложных, дефицитных, либо снятых с производства позиций;
- Оперативные сроки поставки под заказ (от 5 рабочих дней);
- Экспресс доставка в любую точку России;
- Техническая поддержка проекта, помощь в подборе аналогов, поставка прототипов;
- Система менеджмента качества сертифицирована по Международному стандарту ISO 9001;
- Лицензия ФСБ на осуществление работ с использованием сведений, составляющих государственную тайну;
- Поставка специализированных компонентов (Xilinx, Altera, Analog Devices, Intersil, Interpoint, Microsemi, Aeroflex, Peregrine, Syfer, Eurofarad, Texas Instrument, Miteq, Cobham, E2V, MA-COM, Hittite, Mini-Circuits, General Dynamics и др.);

Помимо этого, одним из направлений компании «ЭлектроПласт» является направление «Источники питания». Мы предлагаем Вам помощь Конструкторского отдела:

- Подбор оптимального решения, техническое обоснование при выборе компонента;
- Подбор аналогов;
- Консультации по применению компонента;
- Поставка образцов и прототипов;
- Техническая поддержка проекта;
- Защита от снятия компонента с производства.



Как с нами связаться

Телефон: 8 (812) 309 58 32 (многоканальный)

Факс: 8 (812) 320-02-42

Электронная почта: org@eplast1.ru

Адрес: 198099, г. Санкт-Петербург, ул. Калинина, дом 2, корпус 4, литера А.