

50 Ω TERMINATION TYPE HIGH POWER SPDT SWITCH FOR WiMAX

DESCRIPTION

The μ PG2176T5N is a GaAs MMIC 50 Ω termination type high power SPDT (Single Pole Double Throw) switch which was developed for WiMAX. This device can operate frequency from 2.3 to 5.85 GHz, having the low insertion loss and high isolation.

This device is housed in a 6-pin plastic TSON (Thin Small Out-line Non-leaded) package. And this package is able to high-density surface mounting.

FEATURES

- Control voltage : $V_{\text{cont (H)}} = 2.5$ to 5.0 V (3.0 V TYP.)
: $V_{\text{cont (L)}} = -0.3$ to 0.3 V (0 V TYP.)
- Low insertion loss : $L_{\text{ins1}} = 0.45$ dB TYP. @ $f = 2.3$ to 2.7 GHz, $V_{\text{cont (H)}} = 3.0$ V, $V_{\text{cont (L)}} = 0$ V
: $L_{\text{ins2}} = 0.55$ dB TYP. @ $f = 3.3$ to 3.8 GHz, $V_{\text{cont (H)}} = 3.0$ V, $V_{\text{cont (L)}} = 0$ V
: $L_{\text{ins3}} = 0.70$ dB TYP. @ $f = 4.9$ to 5.85 GHz, $V_{\text{cont (H)}} = 3.0$ V, $V_{\text{cont (L)}} = 0$ V
- High isolation : $ISL1 = 27$ dB TYP. @ $f = 2.3$ to 2.7 GHz, $V_{\text{cont (H)}} = 3.0$ V, $V_{\text{cont (L)}} = 0$ V
: $ISL2 = 24$ dB TYP. @ $f = 3.3$ to 3.8 GHz, $V_{\text{cont (H)}} = 3.0$ V, $V_{\text{cont (L)}} = 0$ V
: $ISL3 = 21$ dB TYP. @ $f = 4.9$ to 5.85 GHz, $V_{\text{cont (H)}} = 3.0$ V, $V_{\text{cont (L)}} = 0$ V
- Handling power : $P_{\text{in (1 dB)}} = +37.0$ dBm TYP. @ $f = 2.3$ to 2.7 GHz, $V_{\text{cont (H)}} = 3.0$ V, $V_{\text{cont (L)}} = 0$ V
: $P_{\text{in (1 dB)}} = +37.0$ dBm TYP. @ $f = 3.3$ to 3.8 GHz, $V_{\text{cont (H)}} = 3.0$ V, $V_{\text{cont (L)}} = 0$ V
: $P_{\text{in (1 dB)}} = +37.0$ dBm TYP. @ $f = 4.9$ to 5.85 GHz, $V_{\text{cont (H)}} = 3.0$ V, $V_{\text{cont (L)}} = 0$ V
- High-density surface mounting : 6-pin plastic TSON package ($1.5 \times 1.5 \times 0.37$ mm)

APPLICATION

- WiMAX and wireless LAN (IEEE802.11a/b/g/n)

ORDERING INFORMATION

Part Number	Order Number	Package	Marking	Supplying Form
μ PG2176T5N-E2	μ PG2176T5N-E2-A	6-pin plastic TSON (Pb-Free)	G4Y	<ul style="list-style-type: none"> • Embossed tape 8 mm wide • Pin 1, 6 face the perforation side of the tape • Qty 3 kpcs/reel

Remark To order evaluation samples, contact your nearby sales office.

Part number for sample order: μ PG2176T5N-A

Caution Observe precautions when handling because these devices are sensitive to electrostatic discharge.

The information in this document is subject to change without notice. Before using this document, please confirm that this is the latest version.

PIN CONNECTIONS AND INTERNAL BLOCK DIAGRAM

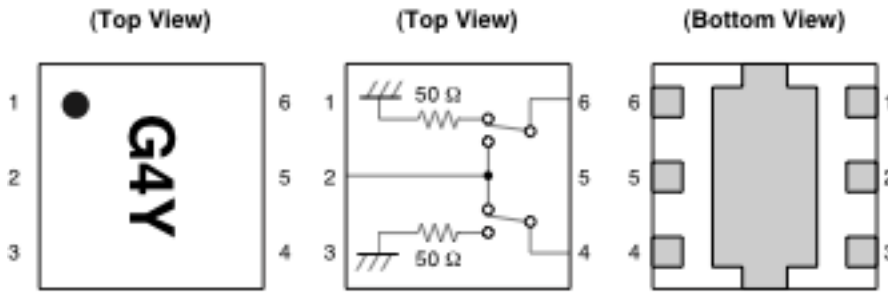

Pin No.	Pin Name
1	V _{cont1}
2	INPUT
3	V _{cont2}
4	OUTPUT2
5	GND
6	OUTPUT1

Remark Exposed pad : GND

TRUTH TABLE

V _{cont1}	V _{cont2}	INPUT-OUTPUT1	INPUT-OUTPUT2
High	Low	ON	OFF
Low	High	OFF	ON

ABSOLUTE MAXIMUM RATINGS (T_A = +25°C, unless otherwise specified)

Parameter	Symbol	Ratings	Unit
Switch Control Voltage	V _{cont}	-6.0 to +6.0 ^{Note}	V
Input Power (ON Port, peak)	P _{in}	+38	dBm
Input Power (ON Port, average)	P _{in}	+28	dBm
Input Power (OFF Port)	P _{in (OFF)}	+20	dBm
Power Dissipation (average)	P _D	150	mW
Operating Ambient Temperature	T _A	-45 to +85	°C
Storage Temperature	T _{stg}	-55 to +150	°C

Note |V_{cont1} - V_{cont2}| ≤ 6.0 V

RECOMMENDED OPERATING RANGE (T_A = +25°C, unless otherwise specified)

Parameter	Symbol	MIN.	TYP.	MAX.	Unit
Operating Frequency	f _{opt1}	2.3	-	2.7	GHz
	f _{opt2}	3.3	-	3.8	GHz
	f _{opt3}	4.90	-	5.85	GHz
Switch Control Voltage (H)	V _{cont (H)}	+2.5	+3.0	+5.0	V
Switch Control Voltage (L)	V _{cont (L)}	-0.3	0	+0.3	V

ELECTRICAL CHARACTERISTICS

(T_A = +25°C, V_{cont} (H) = 3.0 V, V_{cont} (L) = 0 V, DC blocking capacitors = 8 pF, unless otherwise specified)

Parameter	Symbol	Test Conditions	MIN.	TYP.	MAX.	Unit
Insertion Loss 1	L _{ins1}	f = 2.3 to 2.7 GHz	–	0.45	0.70	dB
Insertion Loss 2	L _{ins2}	f = 3.3 to 3.8 GHz	–	0.55	0.80	dB
Insertion Loss 3	L _{ins3}	f = 4.9 to 5.85 GHz	–	0.70	0.95	dB
Isolation 1 (INPUT–OFF Port)	ISL1	f = 2.3 to 2.7 GHz	24	27	–	dB
Isolation 2 (INPUT–OFF Port)	ISL2	f = 3.3 to 3.8 GHz	21	24	–	dB
Isolation 3 (INPUT–OFF Port)	ISL3	f = 4.9 to 5.85 GHz	18	21	–	dB
Isolation 4 (OUTPUT1–OUTPUT2)	ISL4	f = 2.3 to 2.7 GHz	22	25	–	dB
Isolation 5 (OUTPUT1–OUTPUT2)	ISL5	f = 3.3 to 3.8 GHz	20	23	–	dB
Isolation 6 (OUTPUT1–OUTPUT2)	ISL6	f = 4.9 to 5.85 GHz	17	20	–	dB
Input Return Loss 1	RL _{in1}	f = 2.3 to 2.7 GHz	10	15	–	dB
Input Return Loss 2	RL _{in2}	f = 3.3 to 3.8 GHz	10	15	–	dB
Input Return Loss 3	RL _{in3}	f = 4.9 to 5.85 GHz	10	15	–	dB
Output Return Loss 1	RL _{out1}	f = 2.3 to 2.7 GHz	10	15	–	dB
Output Return Loss 2	RL _{out2}	f = 3.3 to 3.8 GHz	10	15	–	dB
Output Return Loss 3	RL _{out3}	f = 4.9 to 5.85 GHz	10	15	–	dB
Unused Port Return Loss 1	URL1	f = 2.3 to 2.7 GHz	10	15	–	dB
Unused Port Return Loss 2	URL2	f = 3.3 to 3.8 GHz	10	15	–	dB
Unused Port Return Loss 3	URL3	f = 4.9 to 5.85 GHz	10	15	–	dB
1 dB Loss Compression Input Power ^{Note}	P _{in (1 dB)}	f = 2.3 to 2.7 GHz	+35.0	+37.0	–	dBm
		f = 3.3 to 3.8 GHz	+35.0	+37.0	–	dBm
		f = 4.9 to 5.85 GHz	+35.0	+37.0	–	dBm
Switch Control Current	I _{cont}	RF None	–	16	30	μA
Switch Control Speed	t _{sw}	50% CTL to 90/10% RF	–	100	250	ns

Note P_{in (1 dB)} is measured the input power level when the insertion loss increases more 1 dB than that of linear range.

EVALUATION CIRCUIT

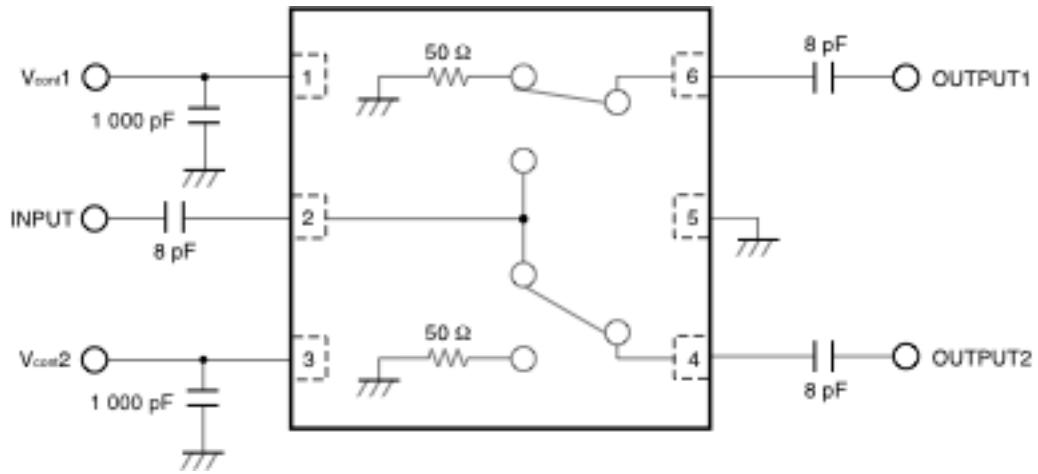

The application circuits and their parameters are for reference only and are not intended for use in actual design-ins.

<R> MOUNTING PAD AND SOLDER MASK LAYOUT DIMENSIONS

6-PIN PLASTIC TSON (UNIT: mm)

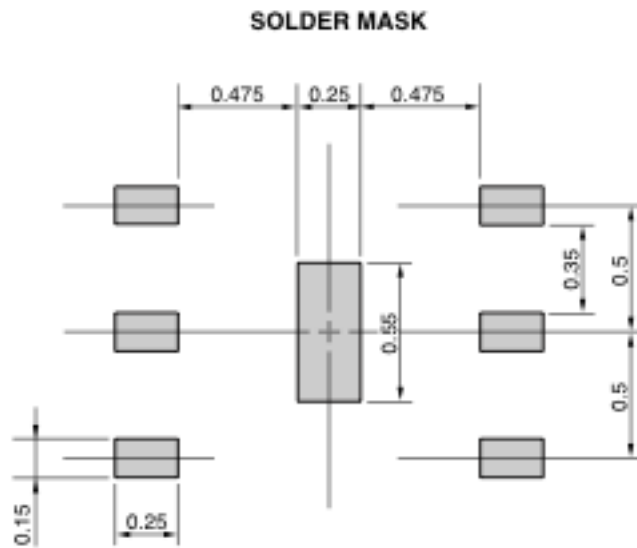
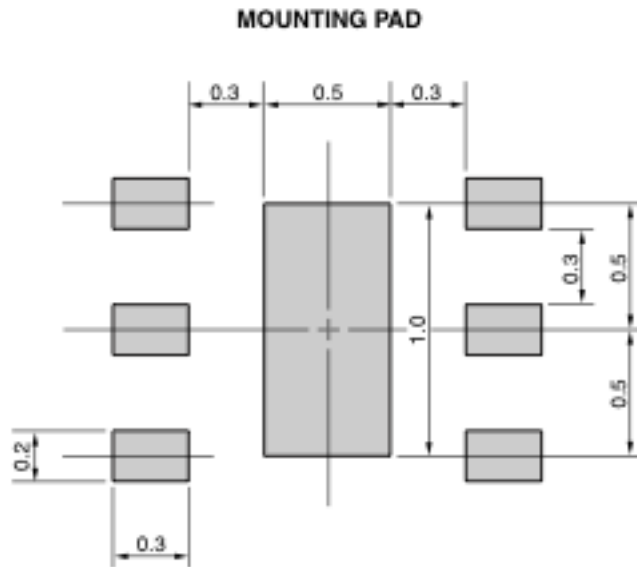

Solder thickness : 0.08 mm

Remark The mounting pad and solder mask layouts in this document are for reference only.

<R> **PACKAGE DIMENSIONS**

6-PIN PLASTIC TSON (UNIT: mm)

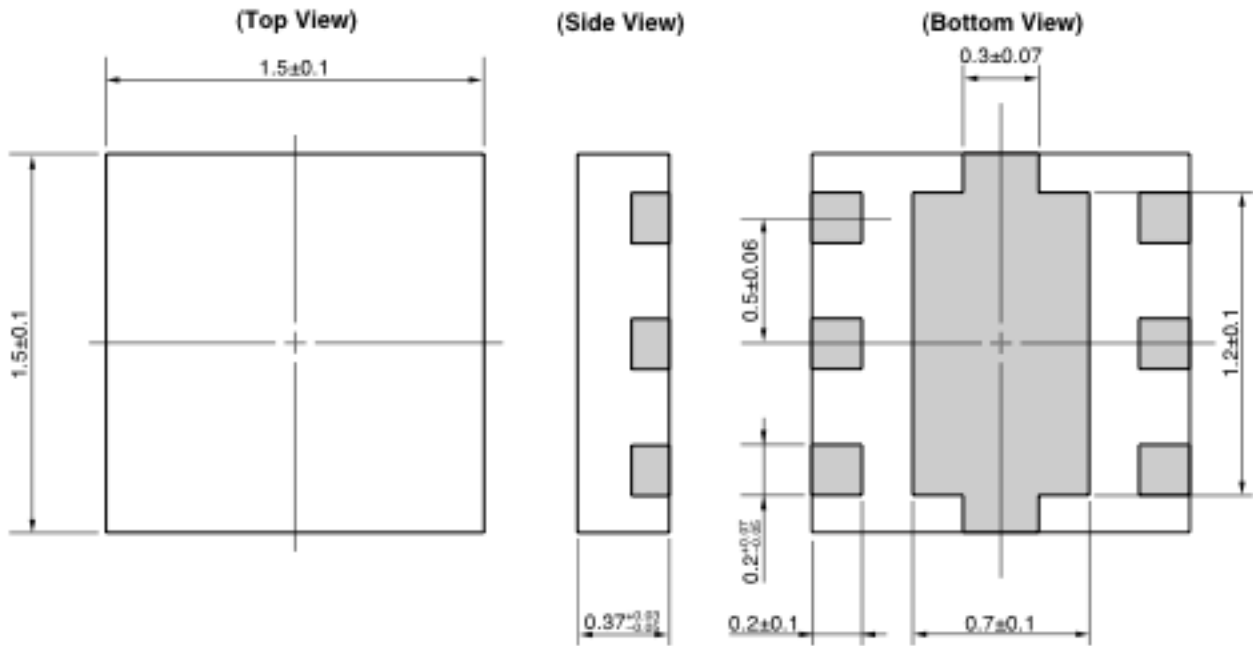

RECOMMENDED SOLDERING CONDITIONS

This product should be soldered and mounted under the following recommended conditions. For soldering methods and conditions other than those recommended below, contact your nearby sales office.

Soldering Method	Soldering Conditions	Condition Symbol
Infrared Reflow	Peak temperature (package surface temperature) : 260°C or below Time at peak temperature : 10 seconds or less Time at temperature of 220°C or higher : 60 seconds or less Preheating time at 120 to 180°C : 120±30 seconds Maximum number of reflow processes : 3 times Maximum chlorine content of rosin flux (% mass) : 0.2%(Wt.) or below	IR260
Wave Soldering	Peak temperature (molten solder temperature) : 260°C or below Time at peak temperature : 10 seconds or less Preheating temperature (package surface temperature) : 120°C or below Maximum number of flow processes : 1 time Maximum chlorine content of rosin flux (% mass) : 0.2%(Wt.) or below	WS260
Partial Heating	Peak temperature (terminal temperature) : 350°C or below Soldering time (per side of device) : 3 seconds or less Maximum chlorine content of rosin flux (% mass) : 0.2%(Wt.) or below	HS350

Caution Do not use different soldering methods together (except for partial heating).

<p>Caution</p>	<p>GaAs Products</p>	<p>This product uses gallium arsenide (GaAs). GaAs vapor and powder are hazardous to human health if inhaled or ingested, so please observe the following points.</p> <ul style="list-style-type: none"> • Follow related laws and ordinances when disposing of the product. If there are no applicable laws and/or ordinances, dispose of the product as recommended below. <ol style="list-style-type: none"> 1. Commission a disposal company able to (with a license to) collect, transport and dispose of materials that contain arsenic and other such industrial waste materials. 2. Exclude the product from general industrial waste and household garbage, and ensure that the product is controlled (as industrial waste subject to special control) up until final disposal. <ul style="list-style-type: none"> • Do not burn, destroy, cut, crush, or chemically dissolve the product. • Do not lick the product or in any way allow it to enter the mouth.
-----------------------	----------------------	---



Компания «ЭлектроПласт» предлагает заключение долгосрочных отношений при поставках импортных электронных компонентов на взаимовыгодных условиях!

Наши преимущества:

- Оперативные поставки широкого спектра электронных компонентов отечественного и импортного производства напрямую от производителей и с крупнейших мировых складов;
- Поставка более 17-ти миллионов наименований электронных компонентов;
- Поставка сложных, дефицитных, либо снятых с производства позиций;
- Оперативные сроки поставки под заказ (от 5 рабочих дней);
- Экспресс доставка в любую точку России;
- Техническая поддержка проекта, помощь в подборе аналогов, поставка прототипов;
- Система менеджмента качества сертифицирована по Международному стандарту ISO 9001;
- Лицензия ФСБ на осуществление работ с использованием сведений, составляющих государственную тайну;
- Поставка специализированных компонентов (Xilinx, Altera, Analog Devices, Intersil, Interpoint, Microsemi, Aeroflex, Peregrine, Syfer, Eurofarad, Texas Instrument, Miteq, Cobham, E2V, MA-COM, Hittite, Mini-Circuits, General Dynamics и др.);

Помимо этого, одним из направлений компании «ЭлектроПласт» является направление «Источники питания». Мы предлагаем Вам помощь Конструкторского отдела:

- Подбор оптимального решения, техническое обоснование при выборе компонента;
- Подбор аналогов;
- Консультации по применению компонента;
- Поставка образцов и прототипов;
- Техническая поддержка проекта;
- Защита от снятия компонента с производства.



Как с нами связаться

Телефон: 8 (812) 309 58 32 (многоканальный)

Факс: 8 (812) 320-02-42

Электронная почта: org@eplast1.ru

Адрес: 198099, г. Санкт-Петербург, ул. Калинина, дом 2, корпус 4, литера А.