

Ultra high voltage ceramic capacitors

With metal terminals

For distribution lines

FD/MD series

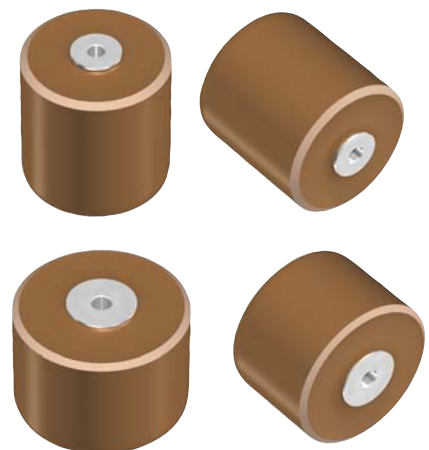

REMINDERS FOR USING THESE PRODUCTS
(1) During transportation and storage

Do not transport or store where the products will be exposed to high temperature or high humidity.

Do not expose to poisonous gases such as H₂SO₄, HCl, or HNO₃.

Avoid excessive impact such as that caused by falling.

(2) During operation

Avoid contact with electrolytes such as perspiration. Do not touch with bare hands.

Avoid excessive impact such as that caused by falling.

Do not apply solder to stud terminals.

Do not re-machine the terminals.

(3) Usage

Make sure that the products are not exposed to radiant heat from chambers or transformers.

(4) Others

The products listed on this catalog are not designed or warranted to meet the requirements of the applications listed below, whose performance and/or quality require a more stringent level of safety or reliability, or whose failure, malfunction or trouble could cause serious damage to society, person or property.

If you intend to use the products in the applications listed below or if you have special requirements exceeding the range or conditions set forth in the each catalog, please contact us.

(1) Aerospace/aviation equipment

(2) Transportation equipment (cars, electric trains, ships, etc.)

(3) Medical equipment

(4) Power-generation control equipment

(5) Atomic energy-related equipment

(6) Seabed equipment

(7) Transportation control equipment

(8) Public information-processing equipment

(9) Military equipment

(10) Electric heating apparatus, burning equipment

(11) Disaster prevention/crime prevention equipment

(12) Safety equipment

(13) Other applications that are not considered general-purpose applications

When designing your equipment even for general-purpose applications, you are kindly requested to take into consideration securing protection circuit/device or providing backup circuits in your equipment.

Ultra high voltage ceramic capacitors

Product compatible with RoHS directive

With metal terminals

For distribution lines

Overview of the FD/MD series

FEATURES

- FD series (rated voltage Eac:10 to 25 kV) and MD series (rated voltage Eac:20kV) available
- Molded type metal screw terminals for easy mounting
- Uses high-reliability mold resin
- Extremely stable temperature characteristics

APPLICATION

Distribution line switches (zero-phase detection, demarcation point), traded volume detection

OPERATING TEMPERATURE RANGE, PRODUCT WEIGHT

Part No.	Sub part No.	Temperature range		Individual weight (g)
		Operating temperature (°C)	Storage temperature (°C)	
FD-9A	60710YP101K4AAA	-30 to +85	-30 to +85	10
FD-10A	60715YP251K4AAAU	-30 to +85	-30 to +85	16
FD-11A	60723YP501K4AAAU	-30 to +85	-30 to +85	30
FD-12A	60731YP102K4AAAU	-30 to +85	-30 to +85	54
FD-16A	60718YP251K4CAAU	-30 to +85	-30 to +85	31
FD-18A	60726YP501K4CAAU	-30 to +85	-30 to +85	71
FD-20A	60737YP102K4CAAU	-30 to +85	-30 to +85	141
FD-22A	60723YP251K4DAA	-30 to +85	-30 to +85	67
FD-24A	60732YP501K4DAAU	-30 to +85	-30 to +85	127
FD-33A	60726YP251K4EAAU	-30 to +85	-30 to +85	107
FD-36A	60736YP501K4EAAU	-30 to +85	-30 to +85	117
MD-1A	60729CH500J3KAA	-30 to +85	-30 to +85	101

• Secondary-molded AU type is also available.

○ RoHS Directive Compliant Product: See the following for more details. <https://product.tdk.com/info/en/environment/rohs/index.html>

 Please be sure to request delivery specifications that provide further details on the features and specifications of the products for proper and safe use.
Please note that the contents may change without any prior notice due to reasons such as upgrading.

FD series

SHAPE & DIMENSIONS

FD-9A to FD-16A

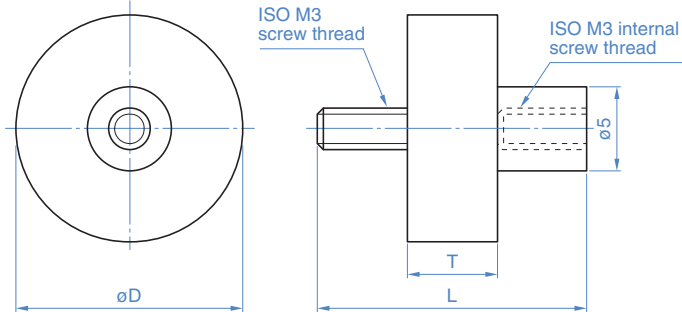

MARKINGS

FD-9A	Part No.
101K	Nominal capacitance and tolerance code
AC10kV	Rated voltage
TDK	Manufacturer's name (TDK or TDK logo ma)
1234	Lot No.

Part No.	Sub part No.	ϕD (mm)	T (mm)	L (mm)
FD-9A	60710YP101K4AAA	16	15	27
FD-10A	60715YP251K4AAAU	21	15	27
FD-11A	60723YP501K4AAAU	28	15	27
FD-12A	60731YP102K4AAAU	38	15	27
FD-16A	60718YP251K4CAAU	26	18.5	30.5

FD-18A to FD-36A

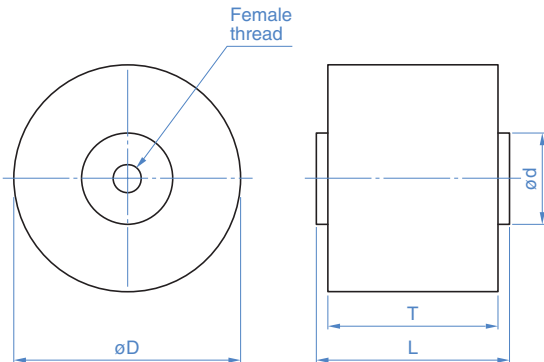

MARKINGS

FD-22A	Part No.
251K	Nominal capacitance and tolerance code
AC20kV	Rated voltage
TDK	Manufacturer's name (TDK or TDK logo ma)
1234	Lot No.

Part No.	Sub part No.	ϕD (mm)	T (mm)	L (mm)	ϕd (mm)	Internal screw
FD-18A	60726YP501K4CAAU	34	23.5	27.5	10	ISO M4
FD-20A	60737YP102K4CAAU	48	23.5	27.5	15	ISO M5
FD-22A	60723YP251K4DAA	30	29	33	10	ISO M4
FD-24A	60732YP501K4DAAU	40	29	33	15	ISO M5
FD-33A	60726YP251K4EAAU	34	35	39	10	ISO M4
FD-36A	60736YP501K4EAAU	48	35	39	15	ISO M5

60723YP251K4DAAFD series

ELECTRICAL CHARACTERISTICS

CHARACTERISTICS SPECIFICATION TABLE

Class 2 (Temperature stable)

Temperature characteristics: Y5P(-30 to +85°C, ±10%)

Part No.	Sub part No.	Rated voltage	Capacitance	Supported insulation classes	Withstanding voltage	Dissipation factor(tanδ)	Insulation resistance	AC corona starting voltage [3PC*]
		(kVAC)	(pF)		[1min, in insulating liquid] (kVAC)			
FD-9A	60710YP101K4AAA	10	100±10%	—	15	0.2	10000	12
FD-10A	60715YP251K4AAAU	10	250±10%	—	15	0.2	10000	12
FD-11A	60723YP501K4AAAU	10	500±10%	—	15	0.2	10000	12
FD-12A	60731YP102K4AAAU	10	1,000±10%	—	15	0.2	10000	12
FD-16A	60718YP251K4CAAU	13	250±10%	—	20	0.2	10000	16
FD-18A	60726YP501K4CAAU	13	500±10%	—	20	0.2	10000	16
FD-20A	60737YP102K4CAAU	13	1,000±10%	—	20	0.2	10000	16
FD-22A	60723YP251K4DAA	20	250±10%	6号A	30	0.2	10000	24
FD-24A	60732YP501K4DAAU	20	500±10%	6号A	30	0.2	10000	24
FD-33A	60726YP251K4EAAU	25	250±10%	10号A	40	0.2	10000	32
FD-36A	60736YP501K4EAAU	25	500±10%	10号A	40	0.2	10000	32

* PC : Pico coulomb.

• Secondary-molded AU type is also available.

CAPACITANCE VS. TEMPERATURE CHARACTERISTICS

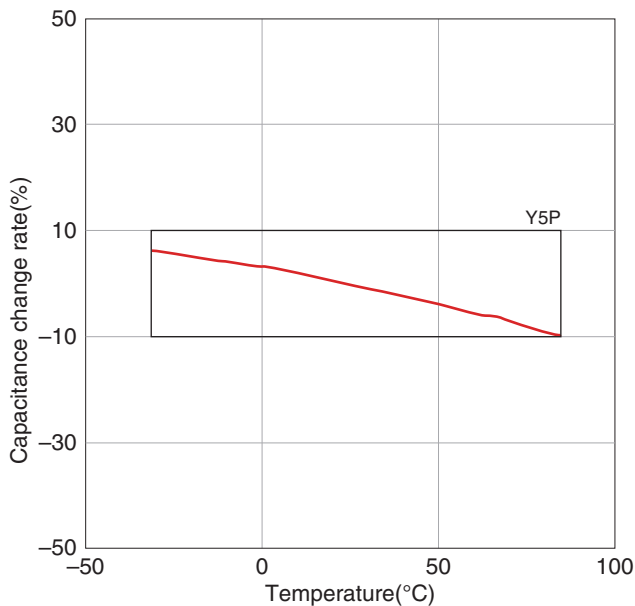

CAPACITANCE VS. AC VOLTAGE CHARACTERISTICS

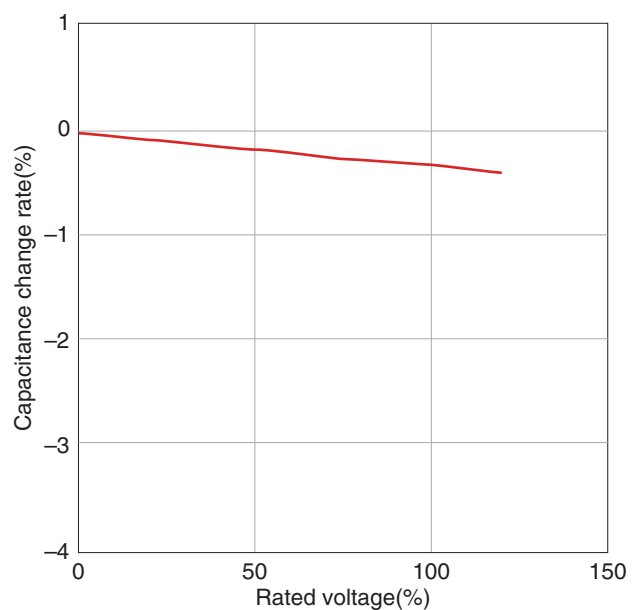

MD series

SHAPE & DIMENSIONS

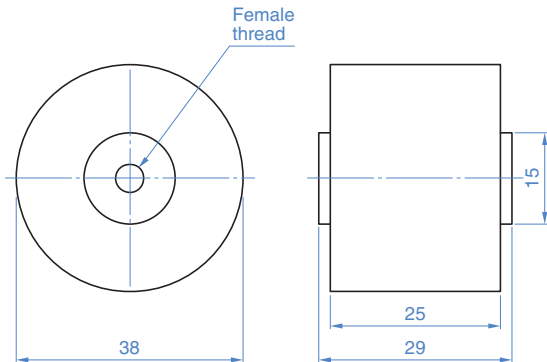

MARKINGS

MD-1A	Part No.
5 0 0 J	Nominal capacitance and tolerance c
AC20kV	Rated voltage
T D K	Manufacturer's name (TDK or TDK Ic
1 2 3 4	Lot No.

ELECTRICAL CHARACTERISTICS

CHARACTERISTICS SPECIFICATION TABLE

Class 1 (low dielectric)

Temperature characteristics: C0H(-55 to +125°C, 0±60ppm/°C)

Part No.	Sub part No.	Rated voltage (kVAC)	Capacitance (pF)	Supported insulation classes	Withstanding voltage [1min, in insulating liquid] (kVAC)	Dissipation factor(tanδ) (%) max.	Insulation resistance (MΩ) min.	AC corona starting voltage [3PC*] (kVAC) min.
MD-1A	60729CH500J3KAA	20	50±5%	6号A	30	0.2	10000	24

* PC : Pico coulomb.



Компания «ЭлектроПласт» предлагает заключение долгосрочных отношений при поставках импортных электронных компонентов на взаимовыгодных условиях!

Наши преимущества:

- Оперативные поставки широкого спектра электронных компонентов отечественного и импортного производства напрямую от производителей и с крупнейших мировых складов;
- Поставка более 17-ти миллионов наименований электронных компонентов;
- Поставка сложных, дефицитных, либо снятых с производства позиций;
- Оперативные сроки поставки под заказ (от 5 рабочих дней);
- Экспресс доставка в любую точку России;
- Техническая поддержка проекта, помощь в подборе аналогов, поставка прототипов;
- Система менеджмента качества сертифицирована по Международному стандарту ISO 9001;
- Лицензия ФСБ на осуществление работ с использованием сведений, составляющих государственную тайну;
- Поставка специализированных компонентов (Xilinx, Altera, Analog Devices, Intersil, Interpoint, Microsemi, Aeroflex, Peregrine, Syfer, Eurofarad, Texas Instrument, Miteq, Cobham, E2V, MA-COM, Hittite, Mini-Circuits, General Dynamics и др.);

Помимо этого, одним из направлений компании «ЭлектроПласт» является направление «Источники питания». Мы предлагаем Вам помощь Конструкторского отдела:

- Подбор оптимального решения, техническое обоснование при выборе компонента;
- Подбор аналогов;
- Консультации по применению компонента;
- Поставка образцов и прототипов;
- Техническая поддержка проекта;
- Защита от снятия компонента с производства.



Как с нами связаться

Телефон: 8 (812) 309 58 32 (многоканальный)

Факс: 8 (812) 320-02-42

Электронная почта: org@eplast1.ru

Адрес: 198099, г. Санкт-Петербург, ул. Калинина, дом 2, корпус 4, литера А.