

WARNING: The LEDs on this demo board produce very bright light. Do not look directly at LEDs when power is applied. Serious eye damage may occur.

DESCRIPTION

Demonstration Circuit 909 is a Multi-LED Camera Light Charge Pump featuring the LTC3217.

The LTC3217 is a low noise charge pump designed to power four high current LEDs. The LTC3217 requires only four small ceramic capacitors plus two resistors to form a complete LED power supply and a current controller.

Built-in soft-start circuitry prevents excessive inrush current during start-up and mode changes. High switching frequency enables the use of small external capacitors. Independent high and low current settings are programmed by two external resistors. Shutdown mode and current output levels are selected via two logic inputs. The intensity of the dis-

play may be adjusted by pressing the EN1, EN2, or both buttons. The intensity may be further controlled by pulse width modulating EN2.

An ultra-low dropout current source maintains accurate LED current at very low I_{LED} voltages. Automatic mode switching optimizes efficiency by monitoring the voltage across the LED current source and switching modes only when ILED dropout is detected.

Design files for this circuit board are available. Call the LTC factory.

 , LTC and LT are registered trademarks of Linear Technology Corporation.

QUICK START PROCEDURE

The DC909 is only intended for continuous operation at a current level of 300mA or less. As a result, the higher current settings should only be used for periods less than 10 seconds.

The use of the Demo Circuit 909 requires a DC power supply capable of supplying at least 1A of current.

1. Connect the DC power supply across the **Vin** and **GND** terminals of the board as shown in Figure 1. For best stability and noise performance, use the shortest leads possible between the board and the supply. Capacitor C5 has been placed on the board to assist in offsetting the effects of long power supply leads.
2. Set the output of the supply to a voltage between 2.9V and 4.5V.
3. Pressing either **EN1**, **EN2**, or both of the enable buttons will enable the part and illuminate the LED. The individual LED current settings for the set enable pins are shown in the table 1.

TABLE 1. Enable Pin Truth Table

EN2	EN1	I_{LED}
0	0	0
0	1	25mA
1	0	75mA
1	1	100mA

The **ISET** resistors (R1 and R2) may be replaced with different values to achieve other current levels. The resistance required ($R_{SET} [\Omega]$) to achieve a desired LED current ($I_{LED} [A]$) may be approximately determined by the following equation:

$$R_{SET} = 488 / I_{LED}$$

Pulse width modulation may be performed on demo circuit 909 by connecting a pulse genera-

LTC3217

WARNING: The LEDs on this demo board produce very bright light. Do not look directly at LEDs when power is applied. Serious eye damage may occur.

tor between the **EN2** and **GND** terminals. Set the high pulse voltage to no greater than $V_{IN}+0.3V$ and the low pulse voltage to 0V. The pulse may be varied from a minimum pulse width of 50us and a maximum off time of 1ms to a 100% duty cycle. See the LTC3217 data sheet for more information on this.

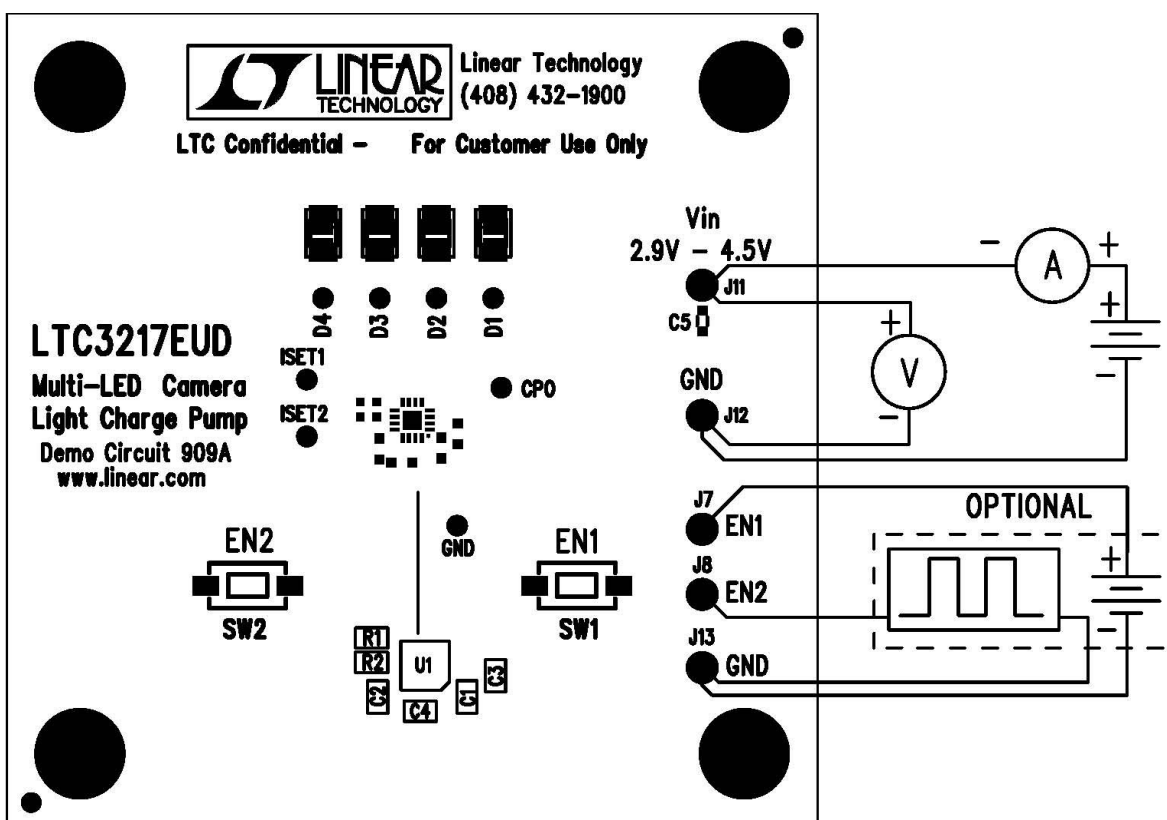

Figure 1. Proper Measurement Equipment Setup for DC909

QUICK START GUIDE FOR DEMONSTRATION CIRCUIT 909

MULTI-LED CAMERA LIGHT CHARGE PUMP

LTC3217

WARNING: The LEDs on this demo board produce very bright light. Do not look directly at LEDs when power is applied. Serious eye damage may occur.

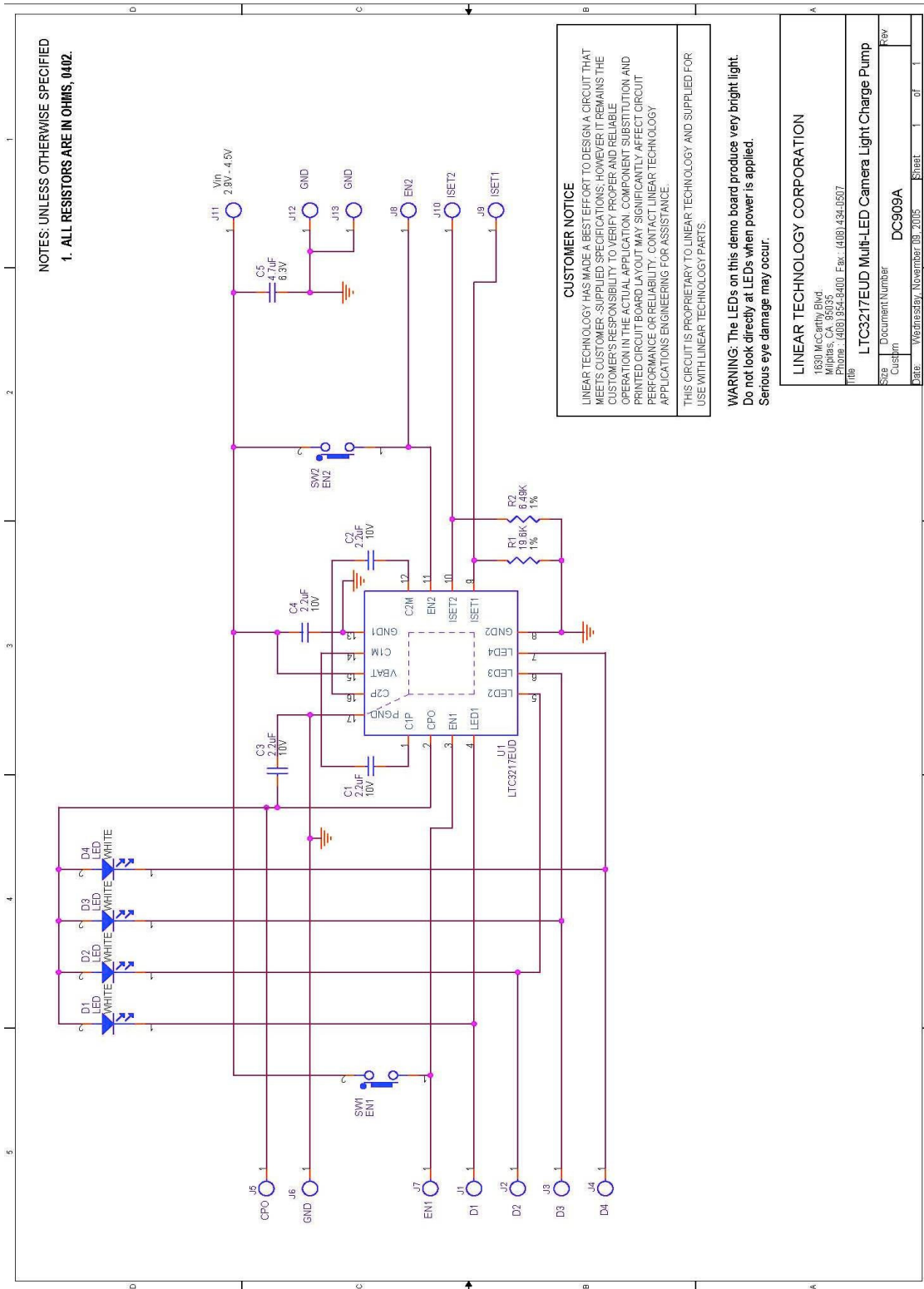



Компания «ЭлектроПласт» предлагает заключение долгосрочных отношений при поставках импортных электронных компонентов на взаимовыгодных условиях!

Наши преимущества:

- Оперативные поставки широкого спектра электронных компонентов отечественного и импортного производства напрямую от производителей и с крупнейших мировых складов;
- Поставка более 17-ти миллионов наименований электронных компонентов;
- Поставка сложных, дефицитных, либо снятых с производства позиций;
- Оперативные сроки поставки под заказ (от 5 рабочих дней);
- Экспресс доставка в любую точку России;
- Техническая поддержка проекта, помощь в подборе аналогов, поставка прототипов;
- Система менеджмента качества сертифицирована по Международному стандарту ISO 9001;
- Лицензия ФСБ на осуществление работ с использованием сведений, составляющих государственную тайну;
- Поставка специализированных компонентов (Xilinx, Altera, Analog Devices, Intersil, Interpoint, Microsemi, Aeroflex, Peregrine, Syfer, Eurofarad, Texas Instrument, Miteq, Cobham, E2V, MA-COM, Hittite, Mini-Circuits, General Dynamics и др.);

Помимо этого, одним из направлений компании «ЭлектроПласт» является направление «Источники питания». Мы предлагаем Вам помощь Конструкторского отдела:

- Подбор оптимального решения, техническое обоснование при выборе компонента;
- Подбор аналогов;
- Консультации по применению компонента;
- Поставка образцов и прототипов;
- Техническая поддержка проекта;
- Защита от снятия компонента с производства.



Как с нами связаться

Телефон: 8 (812) 309 58 32 (многоканальный)

Факс: 8 (812) 320-02-42

Электронная почта: org@eplast1.ru

Адрес: 198099, г. Санкт-Петербург, ул. Калинина, дом 2, корпус 4, литера А.