

AXL E PN DI8 DO4 2A M12 6M

**Axioline E PROFINET device, metal housing,
8 inputs, 4 outputs, 24 V DC,
M12 fast connection technology**



Data sheet
8444_en_04

© PHOENIX CONTACT 2015-10-15

1 Description

The Axioline E device is designed for use within a PROFINET network.

It is used to acquire and output digital signals.

The device is designed for use in systems manufacturing.

It is suitable for use without a control cabinet under harsh industrial conditions.

The Axioline E device can be used on tool platforms, directly on welding robots or in conveying technology, for example.

PROFINET features

- Connection to PROFINET network using M12 connectors (D-coded)
 - 2 Ethernet ports (with integrated switch)
 - Transmission speed 100 Mbps

- PROFINET RT (RTC 1) supported with minimum cycle time of 1 ms
- Supported protocols: SNMP, LLDP, MRP, DCP
- PROFINET features:
 - FSU, shared device, MRP client, I&M functions 0 - 4
- Specification:
 - Mapping in accordance with PROFINET specification v2.2
 - Mapping as PROFINET IO device (conformance class B)
- Device description using GSDML file
- Firmware can be updated
- Integrated web server for web-based management

Axioline E features

- Connection of digital sensors to M12 connectors (A-coded)
- Diagnostic and status indicators
- Short-circuit and overload protection of the sensor supply
- IP65/67 degree of protection



This data sheet is only valid in association with the associated user manual.

Make sure you always use the latest documentation.

It can be downloaded from the product at phoenixcontact.net/products.



Abbreviations used:

- FSU: Fast startup
- MRP: Media Redundancy Protocol
- I&M: Identification and maintenance

2	Table of contents	
1	Description	1
2	Table of contents	2
3	Ordering data	3
4	Technical data	4
5	Internal circuit diagram	7
6	Pin assignment	8
6.1	PROFINET and power supply connection	8
6.2	PROFINET pin assignment	8
6.3	Pin assignment of the power supply U_S/U_A	8
6.4	Connecting inputs and outputs	9
6.5	Pin assignment of the inputs and outputs	9
7	Connection example	10
8	Connection notes	10
9	Local status and diagnostic indicators	11
9.1	Indicators for Ethernet ports and power supply	11
9.2	Input and output indicators	12
10	PROFINET IO Device	13
10.1	Status module	13
10.2	IO module	13
10.3	Substitute value behavior	14
10.4	Diagnostic messages	15
10.5	LLDP - Link Layer Discovery Protocol	15
10.6	MRP - Media Redundancy Protocol	15
11	FSU - Fast Startup	15
11.1	Shared device	15
11.2	Device replacement	15
11.3	I&M functions	16
12	Startup	17
12.1	Delivery state/default settings	17
12.2	Starting the firmware	17
12.3	Firmware update	17
12.4	Restoring the default settings	17
13	WBM - Web-based management	18
14	SNMP - Simple Network Management Protocol	18
15	Device description file (GSDML)	18

3 Ordering data

Description	Type	Order No.	Pcs./Pkt.
Axioline E-PROFINET device in a metal housing with 8 digital inputs and 4 digital outputs, each with a load capacity of 2 A, 24 V DC, M12 fast connection technology	AXL E PN DI8 DO4 2A M12 6M	2701518	1

Accessories	Type	Order No.	Pcs./Pkt.
An M12 screw plug for the unoccupied M12 sockets of the sensor/actuator cable, boxes and flush-type connectors (Protection and sealing elements)	PROT-M12	1680539	5
Mounting plate for Axioline E metal devices (Assembly)	AXL E MP 60	2701761	1
Snap-in markers, Sheet, white, unlabeled, can be labeled with: THERMOMARK CARD, BLUEMARK CLED, BLUEMARK LED, TOPMARK LASER, Mounting type: snapped into marker carrier, Lettering field: 7 x 10 mm (Marking)	UCT-EM (7X10)	0830765	10

Documentation	Type	Order No.	Pcs./Pkt.
User manual, English, Axioline E: system and installation	UM EN AXL E SYS INST	-	-
Application note, English, Starting up Axioline E PROFINET devices using PC Worx	AH EN AXL E PN PCWORX	-	-
Application note, English, Startup of Axioline E PROFINET devices on a SIMATIC® S7 controller (for experienced S7 users)	AH EN S7 - AXL E PN PRO	-	-

Additional ordering data

For additional accessories, visit phoenixcontact.net/products.

4 Technical data

Dimensions (nominal sizes in mm)

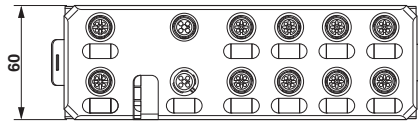
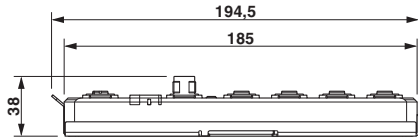

Width	60 mm
Height	185 mm
Depth	38 mm
Note on dimensions	The height is 194.5 mm including the mounting plate. With fixing clips pulled out, the height is 212 mm. The depth is 38 mm including the mounting plate (30.5 mm without the mounting plate).

General data

Housing material	Zinc die-cast
Weight	750 g
Ambient temperature (operation)	-25 °C ... 60 °C



CAUTION: Risk of burns

If the device is used at an ambient temperature above 50°C, the contact temperature of metal surfaces may exceed 70°C.

Ambient temperature (storage/transport)	-25 °C ... 85 °C
Permissible humidity (operation)	5 % ... 95 %
Permissible humidity (storage/transport)	5 % ... 95 %
Air pressure (operation)	70 kPa ... 106 kPa (up to 3000 m above sea level)
Air pressure (storage/transport)	70 kPa ... 106 kPa (up to 3000 m above sea level)
Degree of protection	IP65/IP67
Protection class	III, IEC 61140, EN 61140, VDE 0140-1

Connection data

Connection method	M12 connector
-------------------	---------------

Interface PROFINET

Number	2
Connection method	M12 connectors, D-coded
Designation connection point	Copper cable
Number of positions	4
Transmission speed	100 MBit/s (with auto negotiation)

PROFINET

Equipment type	PROFINET Device
Conformance class	B
Update rate	1 ms
Number of supported application relationships (AR)	2
PROFINET protocols	LLDP, MRP client, DCP, DCE-RPC
Additional protocols	SNMP v1, HTTP, TFTP, FTP

Supply: Module electronics and sensors (U_S)

Connection method	M12 connector (T-coded)
Number of positions	4
Supply voltage	24 V DC
Nominal supply voltage range	18 V DC ... 31.2 V DC (including all tolerances, including ripple)
Typical current consumption	140 mA ±15 % (at 24 V DC)
Current consumption	max. 12 A

Supply: Actuators (U_A)

Connection method	M12 connector (T-coded)
Number of positions	4
Supply voltage	24 V DC
Nominal supply voltage range	18 V DC ... 31.2 V DC (including all tolerances, including ripple)
Typical current consumption	30 mA ±15 % (at 24 V DC)
Current consumption	max. 12 A

Digital inputs

Number of inputs	8 (EN 61131-2 types 1 and 3)
Connection method	M12 connector, double occupancy
Connection method	2, 3, 4-wire
Nominal input voltage	24 V DC
Nominal input current	typ. 3 mA
Sensor current per channel	typ. 0.75 mA (from U _S)
Total sensor current	max. 0.6 A (per device)
Input voltage range "0" signal	-30 V DC ... 5 V DC
Input voltage range "1" signal	11 V DC ... 30 V DC
Input filter time	< 1000 µs
Permissible conductor length to the sensor	30 m
Overload protection, short-circuit protection of sensor supply	Yes

Digital outputs

Number of outputs	4
Connection method	M12 connector, (A-coded)
Connection method	2, 3-wire
Nominal output voltage	24 V DC (from voltage U _A)
Maximum output current per channel	2 A
Nominal load, ohmic	12 W (48 Ω; with nominal voltage)
Nominal load, inductive	12 VA (1.2 H; 48 Ω; with nominal voltage)
Signal delay	max. 150 µs (when switched on) max. 200 µs (when switched off)
Switching frequency	max. 5500 per second (with at least 50 mA load current)

Digital outputs

Switching frequency	max. 1 per second (with inductive load)
Limitation of the voltage induced on circuit interruption	-28 V ... -17 V
Output voltage when switched off	max. 1 V
Output current when switched off	max. 20 µA
Behavior with overload	Auto restart
Reverse voltage resistance to short pulses	Reverse voltage proof
Overcurrent shut-down	min. 2.2 A
verload protection, short-circuit protection of outputs	Electronic

Electrical isolation/isolation of the voltage areas

Test section	Test voltage
24 V supply (communications power and sensor supply, digital inputs)/ bus connection (Ethernet 1)	500 V AC, 50 Hz, 1 min
24 V supply (communications power and sensor supply, digital inputs)/ bus connection (Ethernet 2)	500 V AC, 50 Hz, 1 min
24 V supply (communications power and sensor supply, digital inputs)/FE	500 V AC, 50 Hz, 1 min
Bus connection (Ethernet 1)/FE	500 V AC, 50 Hz, 1 min
Bus connection (Ethernet 2)/FE	500 V AC, 50 Hz, 1 min
Bus connection (Ethernet 1)/bus connection (Ethernet 2)	500 V AC, 50 Hz, 1 min
24 V supply (actuator supply, digital outputs)/ 24 V supply (communications power and sensor supply, digital inputs)	500 V AC, 50 Hz, 1 min
24 V supply (actuator supply, digital outputs)/bus connection (Ethernet 1)	500 V AC, 50 Hz, 1 min
24 V supply (actuator supply, digital outputs)/bus connection (Ethernet 2)	500 V AC, 50 Hz, 1 min
24 V supply (actuator supply, digital outputs)/FE	500 V AC, 50 Hz, 1 min

Mechanical tests

Vibration resistance in acc. with EN 60068-2-6/IEC 60068-2-6	5g
Shock in acc. with EN 60068-2-27/IEC 60068-2-27	30g, 11 ms period, half-sine shock pulse
Continuous shock according to EN 60068-2-27/IEC 60068-2-27	10g

Conformance with EMC Directive 2004/108/EC

Noise immunity test in accordance with EN 61000-6-2

Electrostatic discharge (ESD) EN 61000-4-2/IEC 61000-4-2	Criterion B; 6 kV contact discharge, 8 kV air discharge
Electromagnetic fields EN 61000-4-3/IEC 61000-4-3	Criterion A; Field intensity: 10 V/m
Fast transients (burst) EN 61000-4-4/IEC 61000-4-4	Criterion B, 2 kV
Transient surge voltage (surge) EN 61000-4-5/IEC 61000-4-5	Criterion B; DC supply lines: ±0.5 kV/±0.5 kV (symmetrical/asymmetrical)
Conducted interference EN 61000-4-6/IEC 61000-4-6	Criterion A; Test voltage 10 V

Noise emission test as per EN 61000-6-4

Radio interference properties EN 55022	Class A
----------------------------------------	---------

Approvals

For the latest approvals, please visit phoenixcontact.net/products.

5 Internal circuit diagram

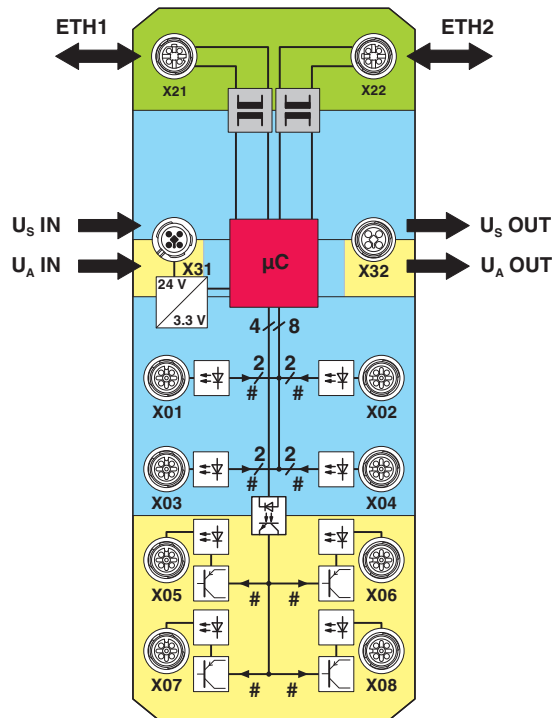

Key:

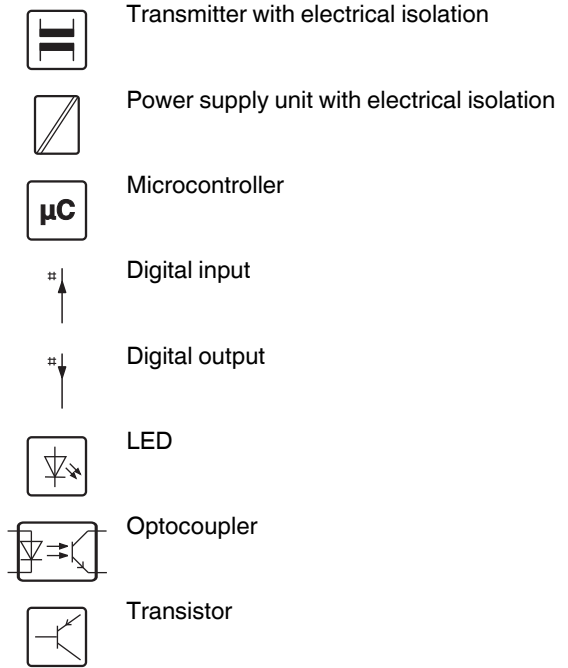

Figure 1 Internal wiring of connections

Key:

Green area: Network
 Blue area: U_S
 Yellow area: U_A

6 Pin assignment

6.1 PROFINET and power supply connection

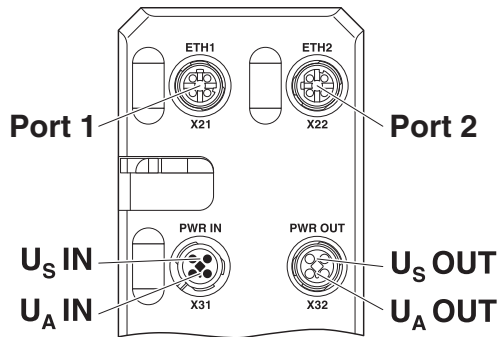

Figure 2 Connections for PROFINET and power supply

Designation	Meaning
Port 1 (X21)	Ethernet port 1
Port 2 (X22)	Ethernet port 2
U _S IN (X31)	Power supply IN (logic and sensors)
U _A IN (X31)	Power supply IN (actuators)
U _S OUT (X32)	Power supply OUT for additional devices
U _A OUT (X32)	Power supply OUT for additional devices



Ground the device by means of the mounting screws of the fixing clips or the mounting plate or the DIN rail.

6.2 PROFINET pin assignment

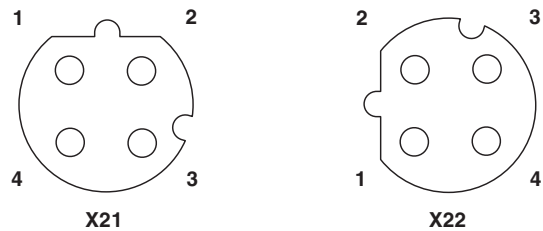

Figure 3 Pin assignment, D-coded

Pin	Ethernet port 1 (X21)	Ethernet port 2 (X22)
1	TX+	TX+
2	RX+	RX+
3	TX-	TX-
4	RX-	RX-



The shield is connected to FE in the device.



The thread is used for additional shielding.

6.3 Pin assignment of the power supply U_S/U_A

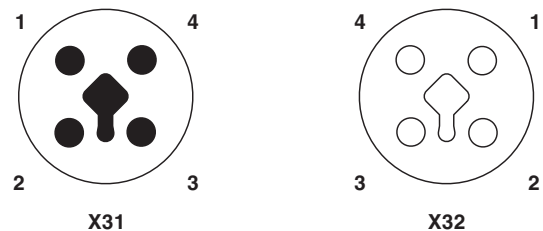

Figure 4 Pin assignment of the power supply, T-coded

Pin	IN	OUT	Conductor colors
1	+24 V DC (U _S)	+24 V DC (U _S)	Brown
2	GND (U _A)	GND (U _A)	White
3	GND (U _S)	GND (U _S)	Blue
4	+24 V DC (U _A)	+24 V DC (U _A)	Black

6.4 Connecting inputs and outputs

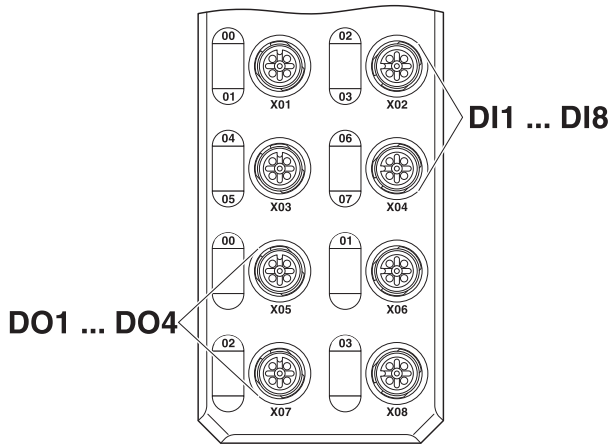

Figure 5 Input and output connections

Designation	Meaning
DI1 ... DI8 (X01 ... X04)	Inputs 1 ... 8
DO1 ... DO4 (X05 ... X08)	Outputs 1 ... 4

6.5 Pin assignment of the inputs and outputs

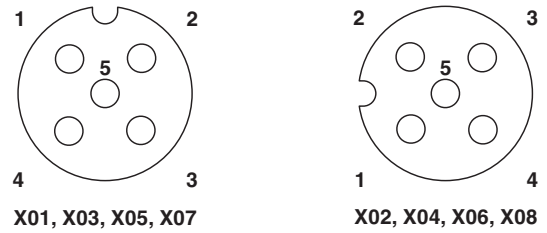

Figure 6 Pin assignment of the inputs and outputs, A-coded

Pin	Input socket	Output socket
1	+24 V DC (U_S)	Not used
2	Input 2, 4, 6, 8	Not used
3	GND	GND
4	Input 1, 3, 5, 7	Output 1, 2, 3, 4
5	FE	FE

7 Connection example

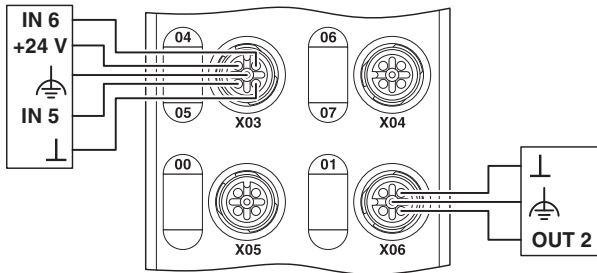

Figure 7 Example of connection of sensors and actuators

8 Connection notes



Note: data corruption or loss

Implement the FE connection using mounting screws, in order to ensure immunity to interference.



NOTE: device damage

To ensure IP65/IP67 protection, cover unused sockets with protective caps.



NOTE: Damage to the electronics

Only supply the sensors with the voltage U_S provided at the terminal points.



NOTE: Damage to the electronics

Observe the correct polarity of the supply voltages U_S and U_A in order to prevent damage to the device.



NOTE: Malfunction

When connecting the sensors and actuators, observe the assignment of the connections to the PROFINET input and output data.



Secure the device to a level surface or to a profile. Do not use this device to bridge gaps, in order to prevent forces being transmitted via the device.



Use standard M5 screws with toothed lock washer and self-locking nuts. Observe the maximum torque of the screws.

9 Local status and diagnostic indicators

9.1 Indicators for Ethernet ports and power supply

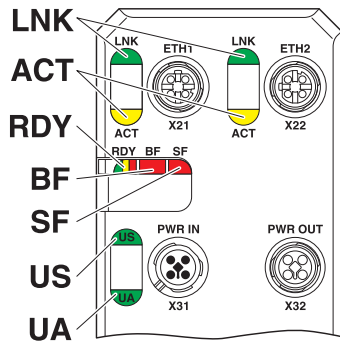

Figure 8 Indicators for Ethernet ports and power supply

Designation	Color	Meaning	State	Description
LNK 1/2	Green	Link	Green ON	Connection present at port 1/2.
			OFF	Connection not present at port 1/2.
ACT 1/2	Yellow	Activity	Yellow flashing	Data transmission present at port 1/2.
			OFF	Data transmission not present at port 1/2.
RDY	Green/ yellow/ red	Ready	Green ON	Device ready to operate
			Yellow flashing	Firmware update is being performed.
			Flashing green/yellow	Over- or undervoltage at U_S
				Temperature of the device is in the critical area.
				Failure of the actuator supply U_A
				Surge voltage/undervoltage of the actuator supply U_A And red US LED: sensor supply overload
OFF	Device is not ready for operation.			
BF	Red	Bus Fault	Red ON	No link status available on any port
			Flashing	SF LED not flashing: Link status available, no communication connection to the PROFINET controller
			Flashing	SF LED flashing: hardware watchdog has been triggered.
			OFF	A PROFINET controller has established an active communication connection to the PROFINET device.
SF	Red	Station Fail	ON	PROFINET diagnostics available
			Flashing	Flashes only together with the BF LED; watchdog triggered
			OFF	PROFINET diagnostics not available
US	Green/ red	U_{Sensorik}	Green ON	Communications power/sensor voltage present
			OFF	Communications power/sensor voltage not present or too low.
			Red ON	Sensor voltage overload
UA	Green	U_{Aktorik}	ON	Actuator voltage present.
			OFF	Actuator voltage not present.

9.2 Input and output indicators

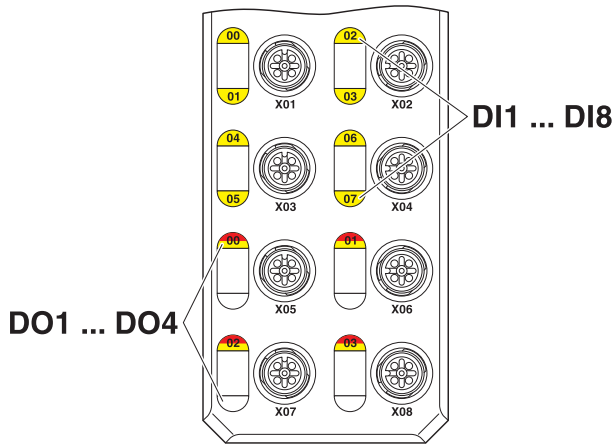

Figure 9 Input and output indicators

Designation	Color	Meaning	State	Description
00 ... 07	Yellow	Status of the inputs	ON	Input is set.
			OFF	Input is not set.
00 ... 03	Yellow/red	Status of the outputs	Yellow ON	Output is set.
			Red ON	Output is short circuited or overloaded.
			OFF	Output is not set.



The numbering of the LEDs is as follows: the first number specifies the byte, the second number specifies the bit.

10 PROFINET IO Device

The Axioline E PROFINET device operates as a PROFINET IO device based on PROFINET specification v2.2.

Slot 1 always contains the “Status module” with 4 bytes of IN process data. Slot 2 contains the IO module, which contains the process data and startup parameters.

10.1 Status module

The status module cyclically provides the following diagnostics options via process data:

Bit 31 ... bit 6	Bit 5	Bit 4	Bit 3	Bit 2	Bit 1	Bit 0
Reserved	Supply of the module electronics and sensors (U_S)		Supply of the actuators (U_A)		Outputs	
Reserved	Undervoltage	Overload	Undervoltage	Short-circuit	Overload	Short-circuit

10.2 IO module

Assignment of the terminal points to the IN process data

The I/O data are mapped as follows:

Input process data								
Byte	Byte 0							
Bit	7	6	5	4	3	2	1	0
IN	07	06	05	04	03	02	01	00
Connection	X04		X03		X02		X01	
Pin	2	4	2	4	2	4	2	4
DI	8	7	6	5	4	3	2	1

Key:

- Bit: Process data assignment
- IN: LED marking
- DI: Device input

Assignment of the terminal points to the OUT process data

The I/O data are mapped as follows:

Output process data								
Byte	Byte 0							
Bit	7	6	5	4	3	2	1	0
OUT	-	-	-	-	03	02	01	00
Connection	-	-	-	-	X08	X07	X06	X05
Pin	-	-	-	-	4	4	4	4
DO	-	-	-	-	4	3	2	1

Key:

- Bit: Process data assignment
- OUT: LED marking
- DO: Device output

10.3 Substitute value behavior

The substitute value behavior is set via the IO module in slot 2. The following parameters are available:

Parameter	Possible values (bold = default)	Description
Failsafe substitute value behavior	0 = reset all outputs (default)	Substitute value behavior for all outputs
	1 = set all outputs	
	2 = hold last value	
	3 = substitute values	
Failsafe substitute values	0 = zero (default) Possible values: 0 ... 65535 _{dec}	Specification of a substitute value pattern for all outputs. In order to use this parameter, you must first set the "Substitute values" in the "Failsafe substitute value behavior" parameter.

10.4 Diagnostic messages

PROFINET enables the PROFINET device to store diagnostic information together with the error location and error type. An incoming alarm informs the PROFINET controller that diagnostic information has been entered.

When the diagnostic information has been removed, an outgoing alarm is sent to the device.

If at least one piece of diagnostic information is stored, the SF LED is on. If no diagnostic information is present, the SF LED is off.

The following PROFINET diagnostic messages are indicated by the PROFINET device:

- Overtemperature of the device
- Surge voltage of U_S
- Overload of U_S
- Surge voltage of U_A
- Undervoltage of U_A
- Short circuit of U_A
- Short circuit of an output
- Output overload



Channel diagnostics are always reported in groups of 4.

10.5 LLDP - Link Layer Discovery Protocol

The device supports LLDP according to IEEE 802.1AB and therefore enables topology detection of devices that also have LLDP activated.

Advantages of using LLDP:

- Improved error location detection
- Improved device replacement
- More efficient network configuration

The following information is received by or sent to neighbors, as long as LLDP is activated:

- The device sends its own management and connection information to neighboring devices.
- The device receives management and connection information from neighboring devices.

Engineering tools can be used to represent the LLDP information as a topology overview.

10.6 MRP - Media Redundancy Protocol

The device supports the role of a Media Redundancy Client (MRC) in an MRP network.



Follow the instructions in the documentation for your engineering tool and controller in order to parameterize this function.

11 FSU - Fast Startup

The device supports the Fast Startup function. This function enables fast startup of the PROFINET device. The device is ready to operate in < 500 ms.



Follow the instructions in the documentation for your engineering tool and controller in order to parameterize this function.

11.1 Shared device

The device supports the shared device function. This enables two controllers to simultaneously establish a cyclic connection to the device and read input data. Writing outputs can only be activated by the first controller.



Follow the instructions in the documentation for your engineering tool and controller in order to parameterize this function.

11.2 Device replacement

Devices can be replaced without having to reconfigure them within the PROFINET network.

Device replacement is only then possible if the new device is in its default state. The controller must support the device replacement function.

The device name and the device address are assigned by the controller to the newly added PROFINET device with the help of the neighborhood detection function.

11.3 I&M functions

The PROFINET device supports Identification & Maintenance functions (I&M). General Identification & Maintenance functions 0 ... 4 can be read via slot 0.

I&M 0 (slot 0)

I&M data	Access / data type	Presets
MANUFACTURER_ID	Read / 2 bytes	B0 _{hex} (Phoenix Contact GmbH & Co. KG)
ORDER_ID	Read / 20 bytes	2701518
SERIAL_Number	Read / 16 bytes	Stipulated in the product process
HARDWARE_Revision	Read / 2 bytes	Corresponds to the hardware version of the device
SOFTWARE_Revision	Read / 4 bytes	Corresponds to the firmware version of the device
REVISION_Counter	Read / 2 bytes	0000 _{hex} (reserved)
PROFILE_ID	Read / 2 bytes	4E00 _{hex} (generic device)
PROFILE_SPECIFIC_TYPE	Read / 2 bytes	0003 _{hex} (IO module)
IM_VERSION	Read / 2 bytes	0101 _{hex} (Version 1.1)
IM_SUPPORTED	Read / 2 bytes	001E _{hex} (I&M 1 ... 4)

I&M 1 (slot 0)

I&M data	Access / data type	Presets
TAG_FUNCTION	Read/write / 32 bytes	"20 _{hex} " (empty)
TAG_LOCATION	Read/write / 22 bytes	"20 _{hex} " (empty)

I&M 2 (slot 0)

I&M data	Access / data type	Presets
INSTALLATION_DATE	Read/write / 16 bytes	"20 _{hex} " (empty)
RESERVED	Read/write / 38 bytes	00 _{hex}

I&M 3 (slot 0)

I&M data	Access / data type	Presets
DESCRIPTOR	Read/write / 54 bytes	"20 _{hex} " (empty)

I&M 4 (slot 0)

I&M data	Access / data type	Presets
SIGNATURE	Read/write / 54 bytes	"20 _{hex} " (empty)

12 Startup

12.1 Delivery state/default settings

By default upon delivery, the following functions and features are available:

PROFINET

PROFINET name:	No name assigned
IP parameters:	0.0.0.0
Subnet mask:	0.0.0.0
Default Gateway:	0.0.0.0
Device designation:	AXL E PN DI8 DO4 2A M12 6M
Vendor ID:	00B0 _{hex}
Device ID:	0104 _{hex}

Firmware update

Firmware update on next restart:	deactivated
TFTP server IP address:	192.168.210.211
Firmware file name:	FIRMWARE.NXF

System identification

Device name:	No name assigned
Description:	No description assigned
Device location:	No location assigned
Contact:	No contact assigned

Web-based Management (WBM)

User name:	admin
Password:	private

12.2 Starting the firmware

Once you have connected the power, the firmware is started.

After completion of the firmware boot process, the RDY LED lights up green.

After completion of the firmware boot process, the BF LED either lights up or flashes.

12.3 Firmware update

In order to update the firmware of the device, the device must be provided with a firmware container via a TFTP server or it must be loaded onto the device via FTP. Any FTP client or TFTP server can be used for this. The update must always be initiated by the web-based management. When carrying out the firmware update, the RDY LED flashes yellow.

12.4 Restoring the default settings

The default settings can be restored via WBM.

To do this, go to:

Administration web page > default settings and follow the instructions.

13 WBM - Web-based management

The device has a web server, which generates the required pages for web-based management and, depending on the requirements of the user, sends them to a standard web browser. Web-based management can be used to access static information (e.g., technical data, MAC address) or dynamic information (e.g., IP address, status information).



You can access web-based management by entering the IP address you assigned to the device in the browser.



If you cannot access the WBM pages, check the connection settings in your browser and deactivate the proxy, if set.

14 SNMP - Simple Network Management Protocol

The device supports SNMP v1.

Management Information Base - MIB



The corresponding latest MIBs are available on the Internet at phoenixcontact.net/products.

For the object descriptions, please refer to the ASN1 descriptions for this product.

The password for read access is “public” and cannot be changed.

By default upon delivery, the password for write/read access is “private” and can be modified at any time.

By default, the password for write and read access is “private” and can be changed at any time.

15 Device description file (GSDML)

PC Worx

Parameterization of the PROFINET device in PC Worx requires at least PC Worx Version 6.30.601. This is part of the AUTOMATION Software Suite 2013, Version 1.80, Order No. 2985660.

An online data sheet of the device with important technical data and a configuration file are integrated into PC Worx. If several versions of the configuration file are available, make sure that you are working with the file version that corresponds to the firmware/hardware version used.

Other tools (STEP 7 ...)

The PROFINET device is parameterized using the configuration tool of the PROFINET controller. For parameterization, integrate the corresponding device GSDML file in the relevant software tool (STEP 7/HW Config, etc.).



For the latest device description files, visit phoenixcontact.net/products. If several versions of the device description file are available, make sure that you are working with the file version that corresponds to the firmware/hardware version used.



Компания «ЭлектроПласт» предлагает заключение долгосрочных отношений при поставках импортных электронных компонентов на взаимовыгодных условиях!

Наши преимущества:

- Оперативные поставки широкого спектра электронных компонентов отечественного и импортного производства напрямую от производителей и с крупнейших мировых складов;
- Поставка более 17-ти миллионов наименований электронных компонентов;
- Поставка сложных, дефицитных, либо снятых с производства позиций;
- Оперативные сроки поставки под заказ (от 5 рабочих дней);
- Экспресс доставка в любую точку России;
- Техническая поддержка проекта, помощь в подборе аналогов, поставка прототипов;
- Система менеджмента качества сертифицирована по Международному стандарту ISO 9001;
- Лицензия ФСБ на осуществление работ с использованием сведений, составляющих государственную тайну;
- Поставка специализированных компонентов (Xilinx, Altera, Analog Devices, Intersil, Interpoint, Microsemi, Aeroflex, Peregrine, Syfer, Eurofarad, Texas Instrument, Miteq, Cobham, E2V, MA-COM, Hittite, Mini-Circuits, General Dynamics и др.);

Помимо этого, одним из направлений компании «ЭлектроПласт» является направление «Источники питания». Мы предлагаем Вам помощь Конструкторского отдела:

- Подбор оптимального решения, техническое обоснование при выборе компонента;
- Подбор аналогов;
- Консультации по применению компонента;
- Поставка образцов и прототипов;
- Техническая поддержка проекта;
- Защита от снятия компонента с производства.



Как с нами связаться

Телефон: 8 (812) 309 58 32 (многоканальный)

Факс: 8 (812) 320-02-42

Электронная почта: org@eplast1.ru

Адрес: 198099, г. Санкт-Петербург, ул. Калинина, дом 2, корпус 4, литера А.