

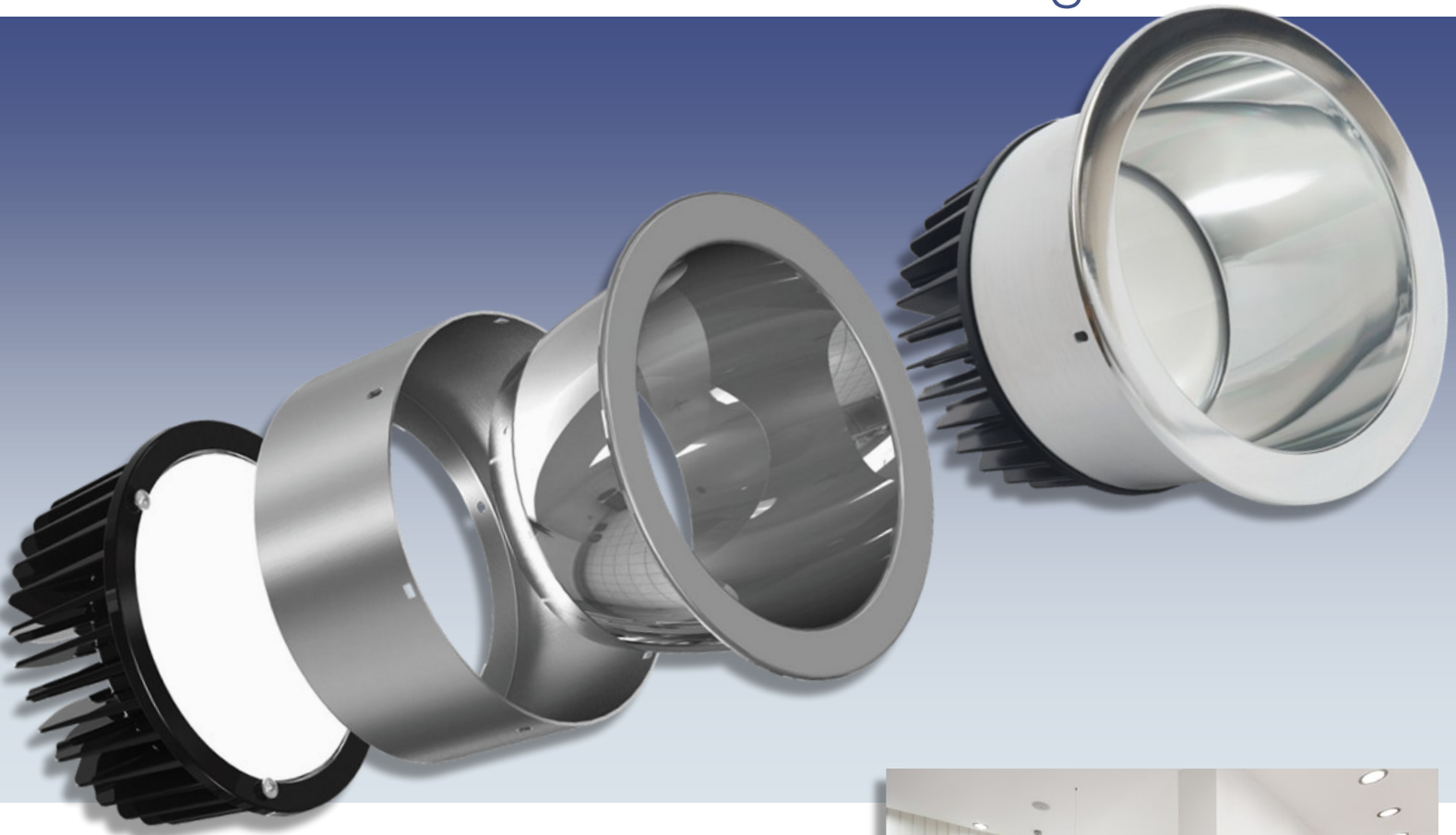

DL2000

High Brightness
6" LED Downlight Module



Overview

Heatron's Innovation Series DL2000 recessed downlight module helps luminaire manufacturers expand their product lines and bring new LED fixtures to market quickly and affordably. The Innovation Series provides OEM's access to an advanced technology platform that has met LM79 approvals and is UL8750 recognized.

The advanced optical system offers a visually comfortable presentation while delivering 2100 lumens using a mere 40 watts of energy. Lighting class LEDs are used in conjunction with a mixing chamber and diffusing lens which shields direct view of LEDs. The reflector design balances the luminaire's brightness and provides a uniform, glare-free appearance.

The downlight module features an integrated cast aluminum thermal design, which efficiently transfers heat away from the LEDs using natural convection and ensures optimal performance and long life.

The DL2000 is designed to last 50,000 hours at L70 and is backed by a 5 year limited warranty.

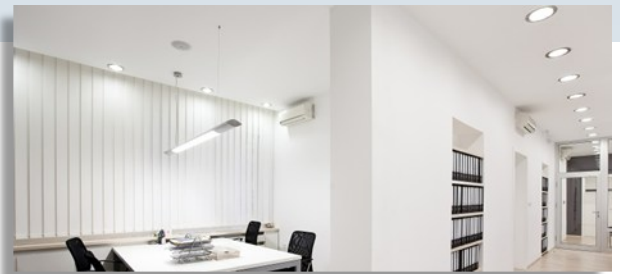

*Transforming Your Vision
into Higher Performance Solutions*

DL2000 6" LED Downlight Module

Mechanical Dimensions

Option 1

Lens, diffuser and retaining ring

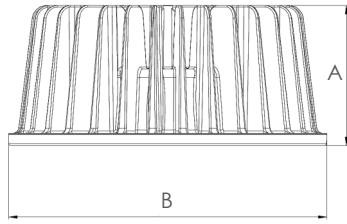

Option 2

Lens, diffuser, lower housing, spring clips and trim ring

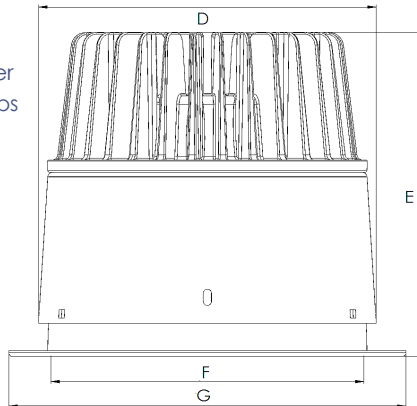

Option 3

Lens, diffuser and lower housing

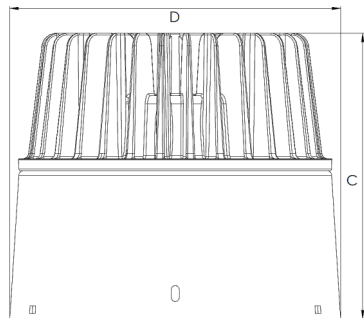

Dimensions	Inches	Millimeters
A	2.70	68.58
B	Ø 6.15	Ø 156.21
C	5.60	142.24
D	Ø 6.50	Ø 165.10
E	6.25	158.75
F	Ø 6.00	Ø 152.40
G	Ø 7.64	Ø 194.06
H	16.89	429.06

Indoor Applications

- Retail
- Commercial
- Hospitality
- Institutions
- Health Care

Key Features

- Light intensity exceeds a 150W incandescent or 32W Watt CFL lamp
- 80 CRI
- Optimized thermal management for maximum performance, long life and reliability
- 5 year limited warranty
- Rapid regulatory approval of final luminaire enabled by using a UL 8750 class II recognized light module
- Contains no mercury

Product Features

Wiring

- Side exit wiring port supplied with 15" armored aluminum BX cable
- Top exit wiring port supplied with 18" 18-gage wire with strain relief

Lens

- Impact-resistant polycarbonate
- High lumen transmission
- Diffusing for uniform illumination

Heat Sink

- High efficiency integrated heat sink effectively transfers heat away from the LED for reliable operation

Weight

- 2.5 lbs. (1.13 kg)

Testing

- Tested in accordance with IESNA LM79 by an independent laboratory

Lifetime

- Estimated Lumen Depreciation (LM80 standard) 70% of initial lumens (L70) at 50,000 hours

LED Module

1. Integrated cast aluminum heat sink
2. Optical mixing chamber with diffuser and lens
3. Lower housing
4. Trim ring
5. Retaining ring

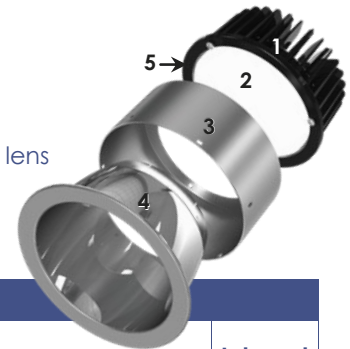

Ordering Information Example: JDHT6R-A1430-8070-S01-NSA

Internal	Series	Internal	Color Temperature	Minimum CRI	Beam Angle	Wiring Port Location	Option	Internal
JDHT	6R	A14	30 - 3000 K 35 - 3500 K 40 - 4000 K	80 80 80	70°	T Top S Side	01 - lens, diffuser and retaining ring 02 - lens, diffuser, lower housing and trim ring 03 - lens, diffuser and lower housing	NSA

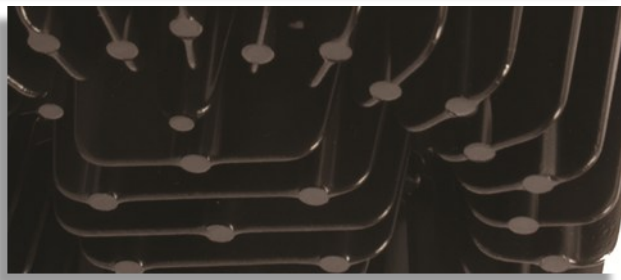

About Heatron LED Integration

Heatron LED Integration helps OEMs reduce costs, speed time to market and ensure superior quality and performance. Heatron LED Integration leverages the engineering disciplines of optical, electrical and mechanical design, with expertise in thermal management.

Offering various levels of integration ranging from design and manufacture of component level LED light engines to turnkey lighting solutions, Heatron designs for a broad range of uses, including indoor, outdoor, commercial, industrial, healthcare and transportation lighting applications.

Heatron, Inc. – *Transforming Your Vision into Higher Performance Solutions.*
For more information about Heatron LED Integration, its products, services and manufacturing, visit www.heatron.com

3000 Wilson Avenue
Leavenworth, KS 66048-4637 USA
877.553.9070
P: 1.913.651.4420 • F: 1.913.651.5352
www.heatron.com • sales@heatron.com
ISO 9001 • Registered by Underwriters Laboratories, Inc.





Компания «ЭлектроПласт» предлагает заключение долгосрочных отношений при поставках импортных электронных компонентов на взаимовыгодных условиях!

Наши преимущества:

- Оперативные поставки широкого спектра электронных компонентов отечественного и импортного производства напрямую от производителей и с крупнейших мировых складов;
- Поставка более 17-ти миллионов наименований электронных компонентов;
- Поставка сложных, дефицитных, либо снятых с производства позиций;
- Оперативные сроки поставки под заказ (от 5 рабочих дней);
- Экспресс доставка в любую точку России;
- Техническая поддержка проекта, помощь в подборе аналогов, поставка прототипов;
- Система менеджмента качества сертифицирована по Международному стандарту ISO 9001;
- Лицензия ФСБ на осуществление работ с использованием сведений, составляющих государственную тайну;
- Поставка специализированных компонентов (Xilinx, Altera, Analog Devices, Intersil, Interpoint, Microsemi, Aeroflex, Peregrine, Syfer, Eurofarad, Texas Instrument, Miteq, Cobham, E2V, MA-COM, Hittite, Mini-Circuits, General Dynamics и др.);

Помимо этого, одним из направлений компании «ЭлектроПласт» является направление «Источники питания». Мы предлагаем Вам помощь Конструкторского отдела:

- Подбор оптимального решения, техническое обоснование при выборе компонента;
- Подбор аналогов;
- Консультации по применению компонента;
- Поставка образцов и прототипов;
- Техническая поддержка проекта;
- Защита от снятия компонента с производства.



Как с нами связаться

Телефон: 8 (812) 309 58 32 (многоканальный)

Факс: 8 (812) 320-02-42

Электронная почта: org@eplast1.ru

Адрес: 198099, г. Санкт-Петербург, ул. Калинина, дом 2, корпус 4, литера А.