

10 9 8 7 6 5 4 3 2 1

F  
E  
D  
C  
B  
A

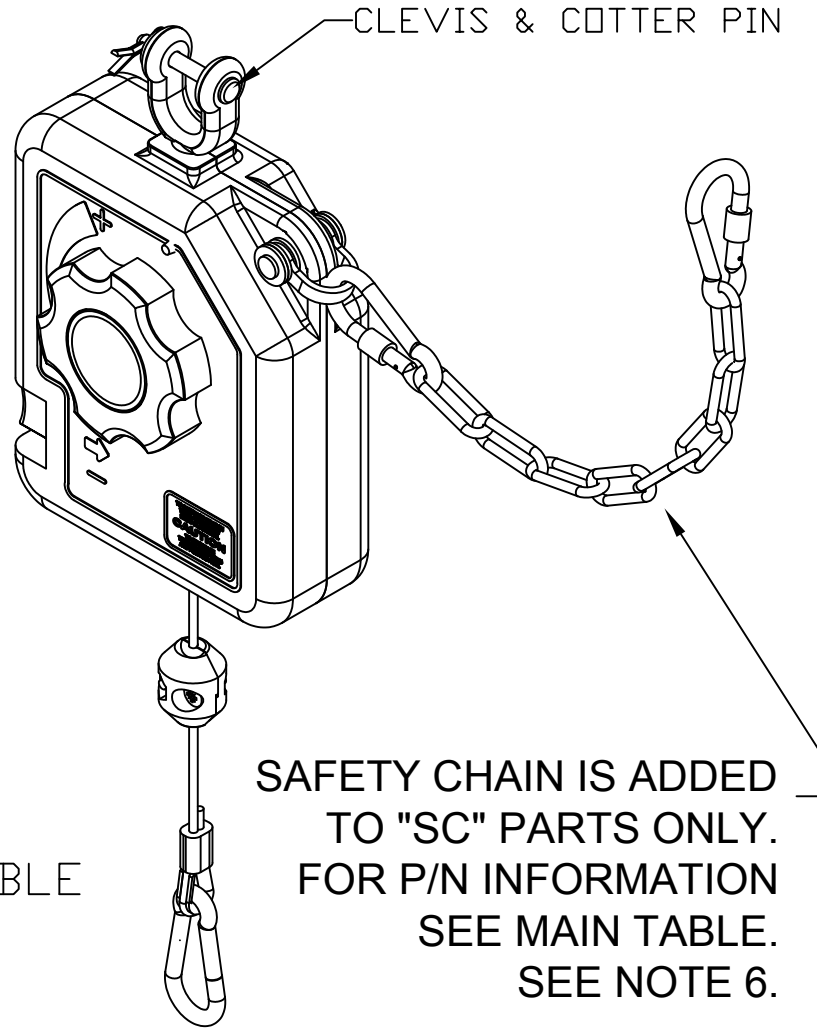
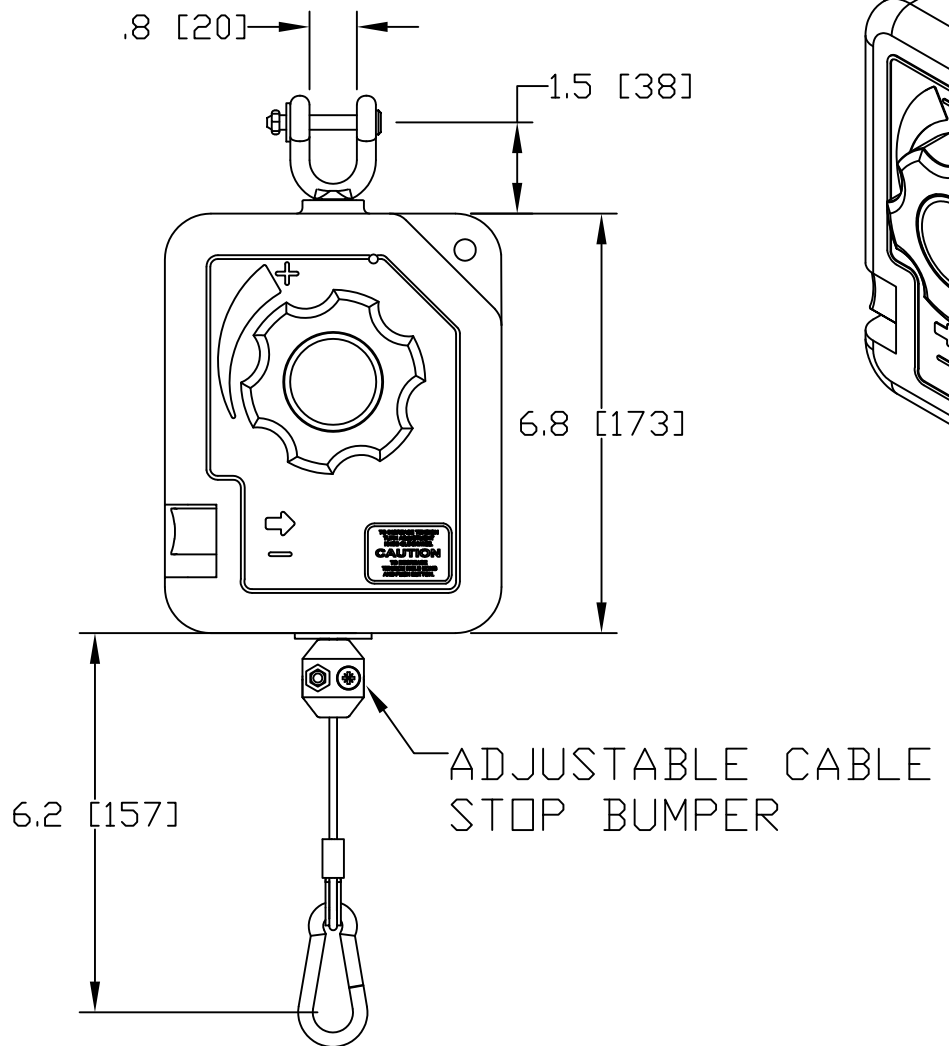
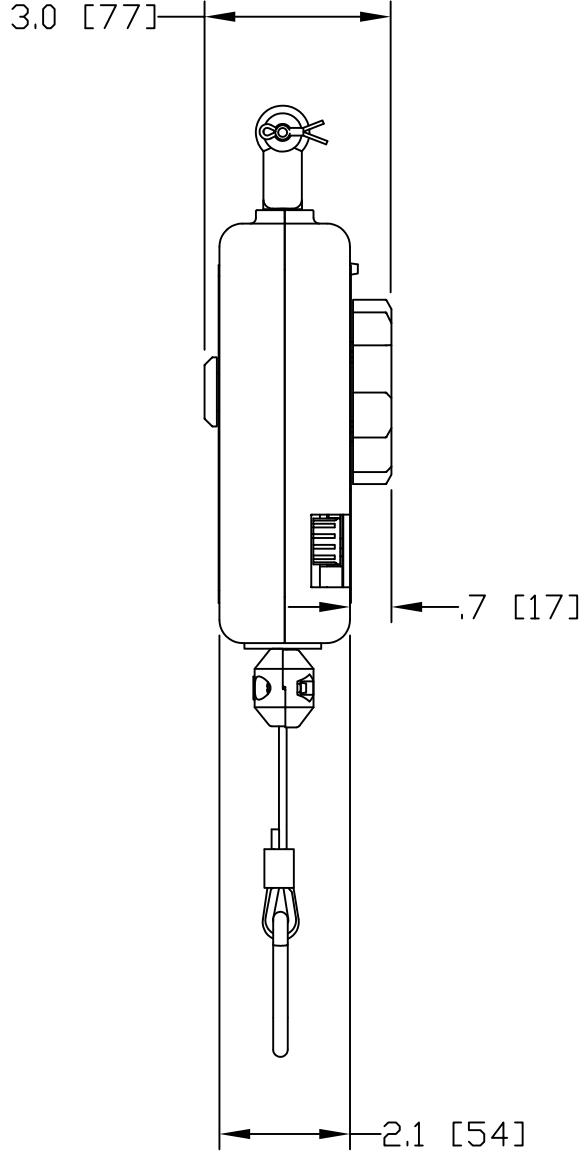
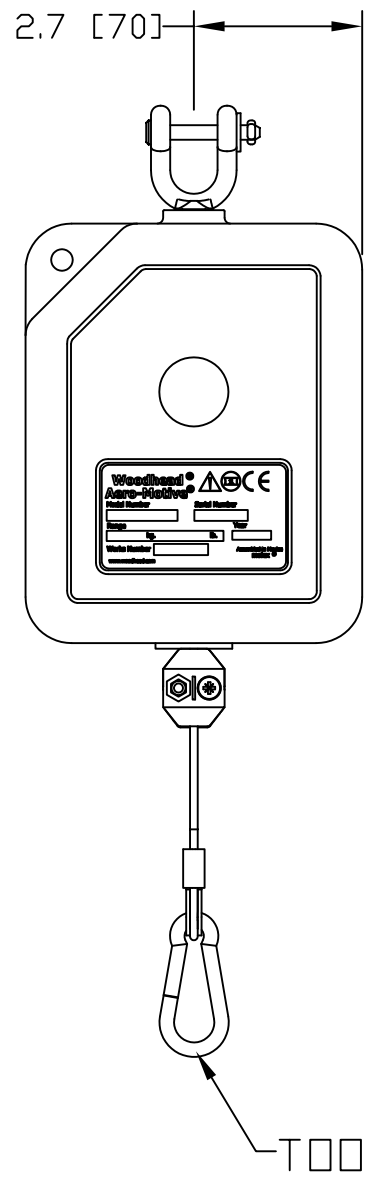

- NOTES:
1. RETRACTORS ARE 100% INSPECTED & PRE-TENSIONED AT FACTORY.
  2. HOUSINGS ARE MADE OF GENERAL PURPOSE ABS TO MEET HARSH INDUSTRIAL ENVIRONMENTS.
  3. ALWAYS READ INSTRUCTIONS MANUAL BEFORE USING RETRACTORS.
  4. RETRACTORS ARE NOT TO BE USED AS BALANCERS THEIR MAIN PURPOSE BEING TO RETRACT A LOAD AND NOT TO BALANCE ONE.
  5. OVERALL DIMENSIONS ARE FOR REFERENCE ONLY.
  6. STANDARD CATALOG RETRACTORS ARE NOT EQUIPED WITH SAFETY CHAIN, BUT IF APPLICATION REQUIRES A SAFETY CHAIN ADD "SC" SUFFIX TO STANDARD BALANCER P/N. EXAMPLE RF6SC. ON MAIN MATERIAL NUMBERS TABLE.
  7. RETRACTORS COME WITH A CLEVIS PIN & A COTTER PIN

RELEASE TO GSM EC NO: WNA2010-0605 DRWN: RHOTCA 2010/03/30 CHKD: DT APPR: DTITUS 2010/04/01	DESCRIPTION A	QUALITY SYMBOLS ▽=0 ▽=0	GENERAL TOLERANCES (UNLESS SPECIFIED)		DIMENSION STYLE		SCALE	DESIGN UNITS	THIRD ANGLE PROJECTION		
			mm	INCH	IN/MM		NTS	INCH			
			4 PLACES	±-	±-	DRAWN BY	DATE	TITLE <b>RF" SERIES OF RETRACTORS</b>			
			3 PLACES	±-	±-	RHOTCA	2010/03/30				
2 PLACES	±-	±-	CHECKED BY	DATE	MATERIAL NO. SEE TABLE						
1 PLACE	±-	±-	DT	2010/03/30							
ANGULAR ±1°			APPROVED BY	DATE	DOCUMENT NO.		SHEET NO.				
DRAFT WHERE APPLICABLE MUST REMAIN WITHIN DIMENSIONS			DTITUS	2010/03/31	SD-130173-002		1 OF 2				
			THIS DRAWING CONTAINS INFORMATION THAT IS PROPRIETARY TO MOLEX INCORPORATED AND SHOULD NOT BE USED WITHOUT WRITTEN PERMISSION								

10 9 8 7 6 5 4 3 2 1

Material Number:	Engineering Number:	Description:	Weight Range in (KG):	Cable Travel in (M):	Weight Range in (LB):	Cable Travel in (FT):	Color:
1301730055	RF6	RF6 RETRACTOR[4-6LB/1.8-2.7KG], 6.6FT	1.8 - 2.7	2.0	4.0 - 6.0	6.6	PUTTY
1301730061	RF8	RF8 RETRACTOR[6-8LB/2.7-3.6KG], 6.6FT	2.7 - 3.6	2.0	6.0 - 8.0	6.6	PUTTY
1301730069	RFL6	RF6 [4-6LB/1.8-2.7KG] W/RATCHET LOCK	1.8 - 2.7	2.0	4.0 - 6.0	6.6	PUTTY
1301730074	RFL8	RF8 [6-8LB/2.7-3.6KG] W/RATCHET LOCK	2.7 - 3.6	2.0	6.0 - 8.0	6.6	PUTTY
1301730057	RF6SC	RF6 [4-6LB/1.8-2.7KG] W/SAFETY CHAIN	1.8 - 2.7	2.0	4.0 - 6.0	6.6	PUTTY
1301730065	RF8SC	RF8 [6-8LB/2.7-3.6KG] W/SAFETY CHAIN	2.7 - 3.6	2.0	6.0 - 8.0	6.6	PUTTY
1301730071	RFL6SC	RFL6 [4-6LB/1.8-2.7KG] W/SAFETY CHAIN	1.8 - 2.7	2.0	4.0 - 6.0	6.6	PUTTY
1301730086	RFL8SC	RFL8 [6-8LB/2.7-3.6KG] W/SAFETY CHAIN	2.7 - 3.6	2.0	6.0 - 8.0	6.6	PUTTY

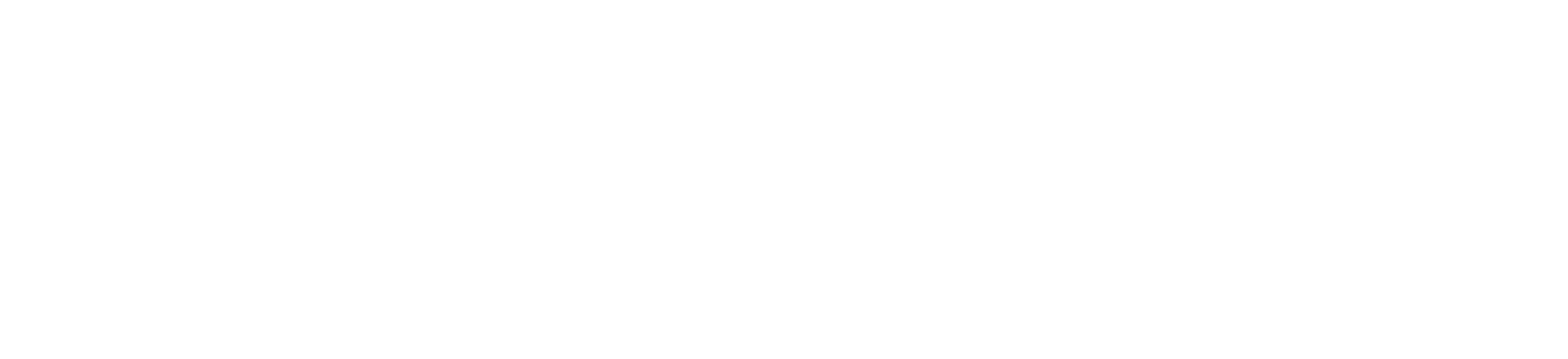

RELEASE TO GSM EC NO: WNA2010-0605 DRWN: RHOTCA 2010/03/30 CHKD: DT APPR: DITUS 2010/04/01	DESCRIPTION REV	QUALITY SYMBOLS ▽=0 ▽=0	GENERAL TOLERANCES (UNLESS SPECIFIED)		DIMENSION STYLE IN/MM		SCALE NTS	DESIGN UNITS INCH	THIRD ANGLE PROJECTION			
				mm	INCH	DRAWN BY	DATE	RF" SERIES OF RETRACTORS ---- MOLEX INCORPORATED				
				4 PLACES	±-	±-	RHOTCA					
				3 PLACES	±-	±-	CHECKED BY	DATE				
		2 PLACES	±-	±-	DT	2010/03/30						
		1 PLACE	±-	±-	APPROVED BY	DATE						
		ANGULAR ±1°		DTITUS	2010/03/31	MATERIAL NO. SEE TABLE		DOCUMENT NO. SD-130173-002		SHEET NO. 2 OF 2		
DRAFT WHERE APPLICABLE MUST REMAIN WITHIN DIMENSIONS			SIZE B		THIS DRAWING CONTAINS INFORMATION THAT IS PROPRIETARY TO MOLEX INCORPORATED AND SHOULD NOT BE USED WITHOUT WRITTEN PERMISSION							



Компания «ЭлектроПласт» предлагает заключение долгосрочных отношений при поставках импортных электронных компонентов на взаимовыгодных условиях!

Наши преимущества:

- Оперативные поставки широкого спектра электронных компонентов отечественного и импортного производства напрямую от производителей и с крупнейших мировых складов;
- Поставка более 17-ти миллионов наименований электронных компонентов;
- Поставка сложных, дефицитных, либо снятых с производства позиций;
- Оперативные сроки поставки под заказ (от 5 рабочих дней);
- Экспресс доставка в любую точку России;
- Техническая поддержка проекта, помощь в подборе аналогов, поставка прототипов;
- Система менеджмента качества сертифицирована по Международному стандарту ISO 9001;
- Лицензия ФСБ на осуществление работ с использованием сведений, составляющих государственную тайну;
- Поставка специализированных компонентов (Xilinx, Altera, Analog Devices, Intersil, Interpoint, Microsemi, Aeroflex, Peregrine, Syfer, Eurofarad, Texas Instrument, Miteq, Cobham, E2V, MA-COM, Hittite, Mini-Circuits, General Dynamics и др.);

Помимо этого, одним из направлений компании «ЭлектроПласт» является направление «Источники питания». Мы предлагаем Вам помощь Конструкторского отдела:

- Подбор оптимального решения, техническое обоснование при выборе компонента;
- Подбор аналогов;
- Консультации по применению компонента;
- Поставка образцов и прототипов;
- Техническая поддержка проекта;
- Защита от снятия компонента с производства.



#### Как с нами связаться

**Телефон:** 8 (812) 309 58 32 (многоканальный)

**Факс:** 8 (812) 320-02-42

**Электронная почта:** [org@eplast1.ru](mailto:org@eplast1.ru)

**Адрес:** 198099, г. Санкт-Петербург, ул. Калинина, дом 2, корпус 4, литера А.