



MP SERIES

Flange Mount AC LVDT

SPECIFICATIONS

- Operation in harsh environments
- Mounting flanges for easy installation
- Stroke ranges from ± 0.5 to ± 10 inches
- AC operation from 400Hz to 5kHz
- Anodized aluminum housing
- Screw terminal wiring
- PTFE bore liner
- Imperial or metric threaded core

The **MP Series** LVDTs provide classic precision performance in harsh industrial environments. The rugged, extruded anodized aluminum housing contains a 100% epoxy encapsulated LVDT, affording superior environmental, mechanical and EMI/RFI protection. The convenient heavy-duty terminal strip replaces multiple lead wires thereby simplifying electrical connection, while the mounting flanges ease mechanical installation. An integral PTFE bore liner provides a smooth, low-friction bearing surface for the core and reduces diametrical clearance.

Available in a variety of stroke ranges from ± 0.5 to ± 10 inches, the MP Series is the ideal choice for industrial mill type applications, power turbines, or wherever aggressive environmental conditions are present. The MP Series is also available with a small diameter/low-mass core, for applications where excessive core weight could influence the motion. The lightweight core can also reduce mechanical stresses and help preserve the structural integrity of the core actuation assembly during high speed displacement or under high vibration. The MP Series is compatible with the full line of Measurement Specialties LVDT signal conditioners, readouts and controllers.

Like in most of our LVDTs, the MP windings are vacuum impregnated with a specially formulated, high temperature, flexible resin, and the coil assembly is potted inside its housing with a two-component epoxy. This provides excellent protection against hostile environments such as high humidity, vibration and shock.

FEATURES

- Rugged aluminum housing
- 100% epoxy encapsulated
- $\pm 0.25\%$ linearity (100% stroke)
- Shock and vibration tolerant
- Screw terminals and mounting flanges
- Calibration certificate supplied with each unit

APPLICATIONS

- Paper mills
- Power turbine valve position
- Rolling mills
- Metal forming presses
- Steel mill “tundish” slide valve feedback
- Progressive rotary press Z-axis feedback

PERFORMANCE SPECIFICATIONS

ELECTRICAL SPECIFICATIONS							
Parameter	MP 500	MP 1000	MP 2000	MP 3000	MP 4000	MP 5000	MP 10000
Stroke range	±0.5 [±12.7]	±1 [±25.4]	±2 [±50.8]	±3 [±76.2]	±4 [±101.6]	±5 [±127]	±10 [±254]
Sensitivity, V/V/inch [mV/V/mm]	0.7 [27.6]	0.39 [15.4]	0.23 [9.1]	0.25 [9.8]	0.20 [7.9]	0.14 [5.5]	0.07 [2.8]
Output at stroke ends, mV/V (*)	350	390	460	750	800	700	700
Phase shift	-1°	-3°	+5°	+11°	+1°	+3°	-5°
Input impedance (PRIMARY)	460Ω	460Ω	330Ω	315Ω	275Ω	310Ω	550Ω
Output impedance (SECONDARY)	375Ω	320Ω	300Ω	830Ω	400Ω	400Ω	750Ω
Non-linearity	% of FR						
@ 50% stroke	0.15	0.15	0.15	0.15	0.15	0.15	0.15
@100% stroke (maximum)	0.25	0.25	0.25	0.25	0.25	0.25	0.25
@125% stroke	0.35	1.00	0.50 (**)	0.50 (**)	0.50 (**)	1.00 (**)	1.00 (**)
@150% stroke	0.75	1.30 (**)	1.00 (**)	1.00 (**)	1.00 (**)	/	/
Input voltage	3 VRMS sine wave						
Input frequency	400Hz to 5kHz						
Test frequency	2.5kHz						
Null voltage (max)	0.5% of FRO						
ENVIRONMENTAL SPECIFICATIONS & MATERIALS							
Operating temperature	-65°F to +300°F [-55°C to 150°C]						
Shock survival	1,000 g (11ms half-sine)						
Vibration tolerance	20 g up to 2kHz						
Housing material	Aluminum, anodized						
Electrical connection	Six terminal barrier strip						
IEC 60529 rating	IP60						

Notes:

All values are nominal unless otherwise noted

Electrical specifications are for the test frequency indicated in the table

Dimensions are in inch [mm] unless otherwise noted

FR: Full Range is the stroke range, end to end; FR=2xS for ±S stroke range

FRO (Full Range Output): difference in outputs measured at the ends of the range

(*) Unit for output at stroke ends is millivolt per volt of excitation (input voltage)

(**) Requires special reduced core length

MECHANICAL SPECIFICATIONS

Parameter	MP 500	MP 1000	MP 2000	MP 3000	MP 4000	MP 5000	MP 10000
Body length "A"	6.50 [165.1]	7.64 [194.1]	11.01 [279.7]	13.85 [351.8]	16.68 [423.7]	18.92 [480.6]	31.90 [810.3]
Core length "B"	3.45 [87.6]	4.00 [101.6]	5.30 [134.6]	5.60 [142.2]	7.00 [177.8]	7.00 [177.8]	8.50 [215.9]
Body weight, oz [g]	12.36 [350]	16.59 [470]	21.00 [595]	26.12 [740]	31.77 [901]	36.18 [1026]	60.89 [1726]
Core weight, oz [g]	0.64 [18]	0.74 [21]	0.95 [27]	0.99 [28]	1.27 [36]	1.27 [36]	1.52 [43]

MP SERIES

Flange Mount AC LVDT

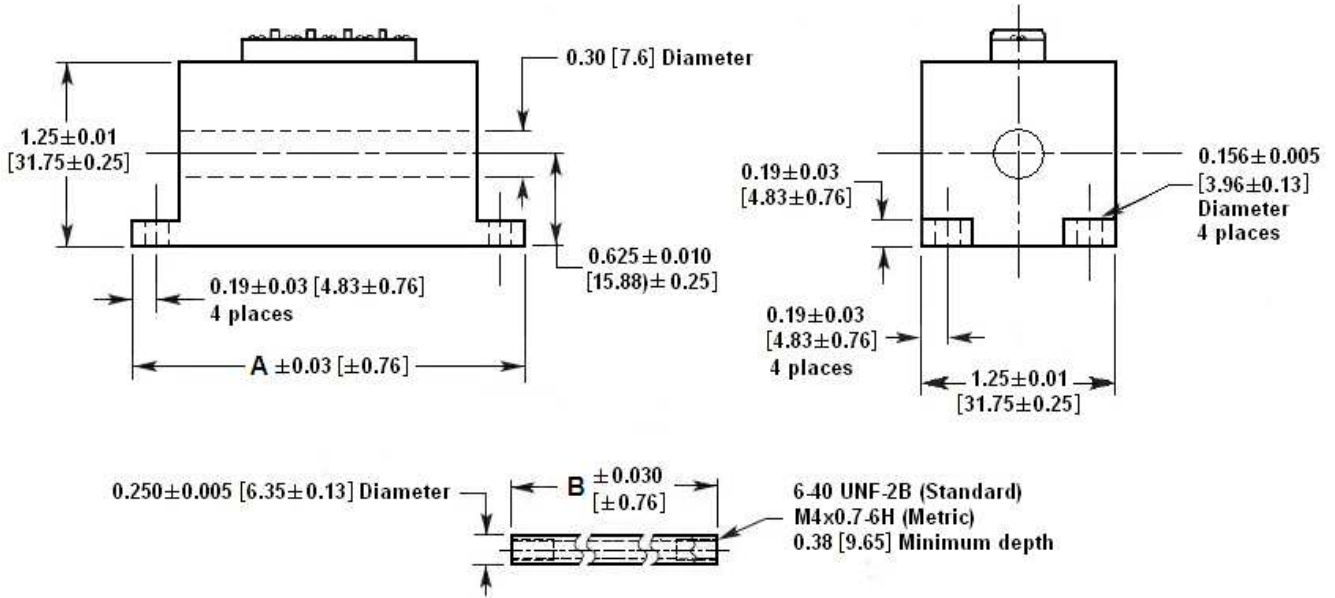

Dimensions are in inch [mm]

WIRING INFORMATION

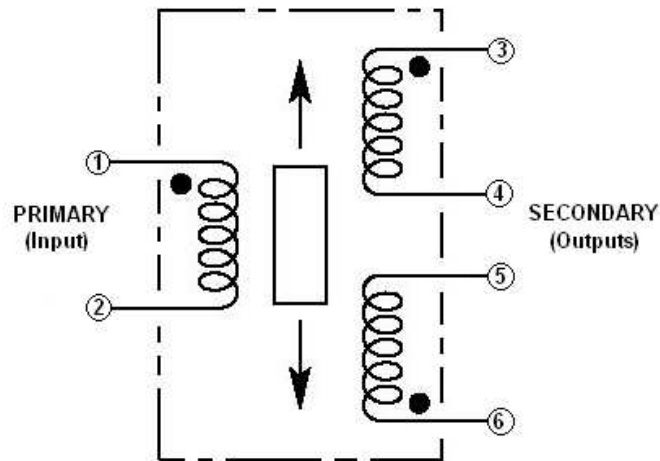

Connect 4 to 5 for differential output

MP SERIES

Flange Mount AC LVDT

ORDERING INFORMATION

Description	Model	Part Number	Description	Model	Part Number
±0.5 inch LVDT	MP 500	02560498-000	±4 inch LVDT	MP 4000	03560390-000
±1 inch LVDT	MP 1000	02560499-000	±5 inch LVDT	MP 5000	02560502-000
±2 inch LVDT	MP 2000	02560500-000	±10 inch LVDT	MP 10000	02560503-000
±3 inch LVDT	MP 3000	02560501-000			
OPTIONS					
5.0 KHz calibration (<i>Available on MP 500 only</i>)					02560498-002
Metric threaded core (M4 x 0.7)					XXXXXXXX-006
Small-diameter/low-mass core (<i>consult factory for mass and dimensions</i>)					XXXXXXXX-020

Note: Add multiple option dash numbers together to determine proper ordering suffix

Example: MP 1000, ±1.0 inch, with 5 KHz calibration and metric core, P/N 02560499-008

ACCESSORIES	
Core connecting rod, 6 inches long, 6-40 threads	05282947-006
Core connecting rod, 12 inches long, 6-40 threads	05282947-012
Core connecting rod, 24 inches long, 6-40 threads	05282947-024
Core connecting rod, 36 inches long, 6-40 threads	05282947-036
Core connecting rod, 6 inches long, M4x0.7 metric threads	05282978-006
Core connecting rod, 12 inches long, M4x0.7 metric threads	05282978-012
Interconnect cable for IEM-422 signal conditioner, stripped & tinned to PTO6A-10-6P connector (1)	04290594-000

(1) Cables are shielded, 10 foot long, and are rated 80°C [176°F] operating. Consult factory for other lengths.

NORTH AMERICA

Measurement Specialties, Inc.,
a TE Connectivity Company
1000 Lucas Way
Hampton, VA 23666
United States
Phone: +1-800-745-8008
Fax: +1-757-766-4297
Email: sales@meas-spec.com

EUROPE

MEAS Deutschland GmbH (Europe)
a TE Connectivity Company
Hauert 13
D-44227 Dortmund
Germany
Phone: +49-(0)231-9740-0
Fax: +49-(0)231-9740-20
Email: info.de@meas-spec.com

ASIA

Measurement Specialties (China), Ltd.,
a TE Connectivity Company
No. 26 Langshan Road
Shenzhen High-Tech Park (North)
Nanshan District, Shenzhen 518057
China
Phone: +86-755-33305088
Fax: +86-755-33305099
Email: info.cn@meas-spec.com

TE.com/sensorsolutions

Measurement Specialties, Inc., a TE Connectivity company.

Accustar, American Sensor Technologies, AST, ATEXIS, DEUTSCH, IdentiCal, TruBlue, KPSI, Krystal Bond, Microfused, UltraStable, Measurement Specialties, MEAS, Schaevitz, TE Connectivity, TE, and the TE connectivity (logo) are trademarks of the TE Connectivity Ltd. family of companies. Other logos, product and company names mentioned herein may be trademarks of their respective owners.

The information given herein, including drawings, illustrations and schematics which are intended for illustration purposes only, is believed to be reliable. However, TE Connectivity makes no warranties as to its accuracy or completeness and disclaims any liability in connection with its use. TE Connectivity's obligations shall only be as set forth in TE Connectivity's Standard Terms and Conditions of Sale for this product and in no case will TE Connectivity be liable for any incidental, indirect or consequential damages arising out of the sale, resale, use or misuse of the product. Users of TE Connectivity products should make their own evaluation to determine the suitability of each such product for the specific application.

© 2015 TE Connectivity Ltd. family of companies All Rights Reserved.



Компания «ЭлектроПласт» предлагает заключение долгосрочных отношений при поставках импортных электронных компонентов на взаимовыгодных условиях!

Наши преимущества:

- Оперативные поставки широкого спектра электронных компонентов отечественного и импортного производства напрямую от производителей и с крупнейших мировых складов;
- Поставка более 17-ти миллионов наименований электронных компонентов;
- Поставка сложных, дефицитных, либо снятых с производства позиций;
- Оперативные сроки поставки под заказ (от 5 рабочих дней);
- Экспресс доставка в любую точку России;
- Техническая поддержка проекта, помощь в подборе аналогов, поставка прототипов;
- Система менеджмента качества сертифицирована по Международному стандарту ISO 9001;
- Лицензия ФСБ на осуществление работ с использованием сведений, составляющих государственную тайну;
- Поставка специализированных компонентов (Xilinx, Altera, Analog Devices, Intersil, Interpoint, Microsemi, Aeroflex, Peregrine, Syfer, Eurofarad, Texas Instrument, Miteq, Cobham, E2V, MA-COM, Hittite, Mini-Circuits, General Dynamics и др.);

Помимо этого, одним из направлений компании «ЭлектроПласт» является направление «Источники питания». Мы предлагаем Вам помощь Конструкторского отдела:

- Подбор оптимального решения, техническое обоснование при выборе компонента;
- Подбор аналогов;
- Консультации по применению компонента;
- Поставка образцов и прототипов;
- Техническая поддержка проекта;
- Защита от снятия компонента с производства.



Как с нами связаться

Телефон: 8 (812) 309 58 32 (многоканальный)

Факс: 8 (812) 320-02-42

Электронная почта: org@eplast1.ru

Адрес: 198099, г. Санкт-Петербург, ул. Калинина, дом 2, корпус 4, литера А.