

Ambient Light Sensor

■ GENERAL DESCRIPTION

The NJL6502R-1 is the ambient light sensor with optical filter to solve the interference problem by the infrared. Also, the spectral response is close to human eye.

■ FEATURES

1. Peak wavelength 580 nm
2. Photo current 420nA±15%
3. Illuminance linearity 0.1 to 100,000 Lux Condition : $V_R=0V$, $T_a=25^\circ C$
4. COBP Package size : 1.7 x 1.2 x 0.8 mm

■ APPLICATIONS

1. Cellular phone, TV, Car navigation system, PND, HUD, PDA, etc.
to adjust the luminance of display.
2. Lighting equipment, Clock, Toy, etc.
to control ON/OFF.
3. Diaphragm control of camera.

■ ABSOLUTE MAXIMUM RATINGS (Ta=25°C)

PARAMETER	SYMBOL	RATINGS	UNIT
Reverse Voltage	V_R	6	V
Operating Temperature	T_{opr}	-30~+85	°C
Storage Temperature	T_{stg}	-40~+100	°C
Soldering Temperature	T_{sol}	260	°C

■ ELECTRO-OPTICAL CHARACTERISTICS (Ta=25°C)

PARAMETER	SYMBOL	TEST CONDITION	MIN	TYP	MAX	UNIT
Forward Current	I_F	$I_F=1mA$, $E_v=0Lux$	—	—	1	V
Dark Current	I_D	$V_R=5V$, $E_v=0Lux$	—	—	0.5	nA
Photo Current 1	I_{L1}	$E_v=1,000Lux$, White LED	357	420	483	nA
Photo Current 2	I_{L2}	$E_v=1,000Lux$, Light source A	—	500	—	nA
Light source A/White LED Light Current Ratio	—	I_{L2}/I_{L1}	—	1.2	—	—
Peak Wavelength	λ_p	—	—	580	—	nm
Capacitance	C_t	FREQ=10kHz, $V_R=0V$	—	35	—	pF

■ OUT LINE

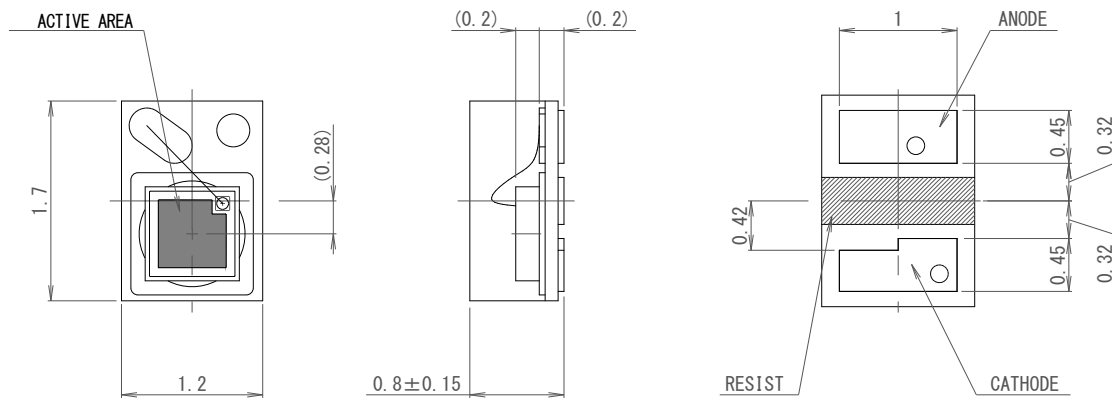

UNIT: mm
GENERAL TOLERANCE: ± 0.1

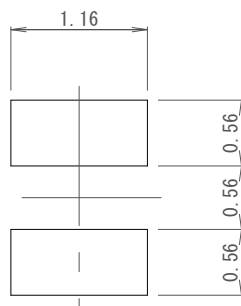

PCB Pattern

■ TYPICAL CHARACTERISTICS

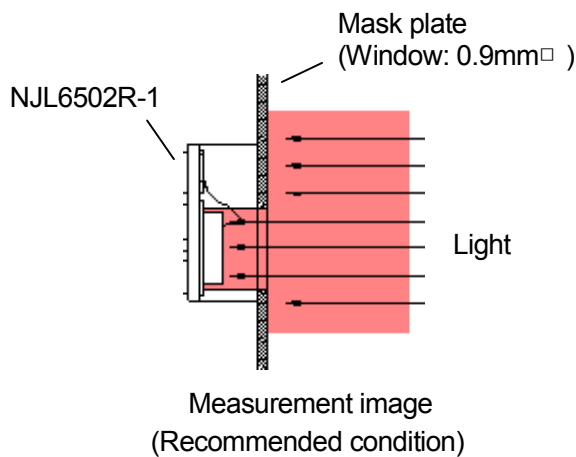
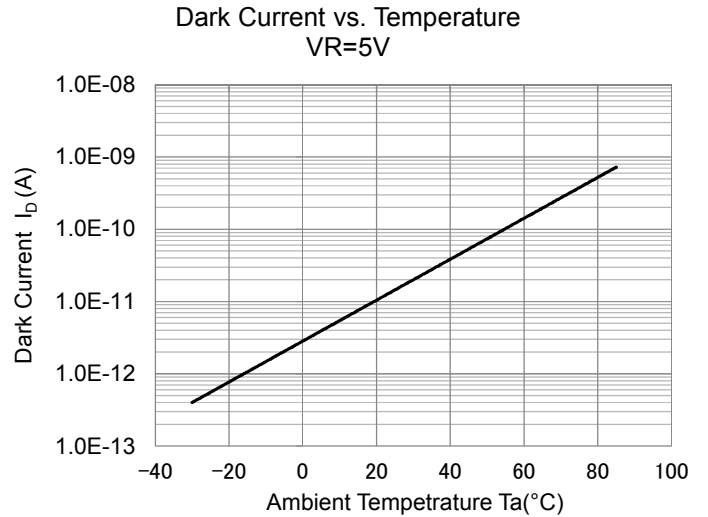
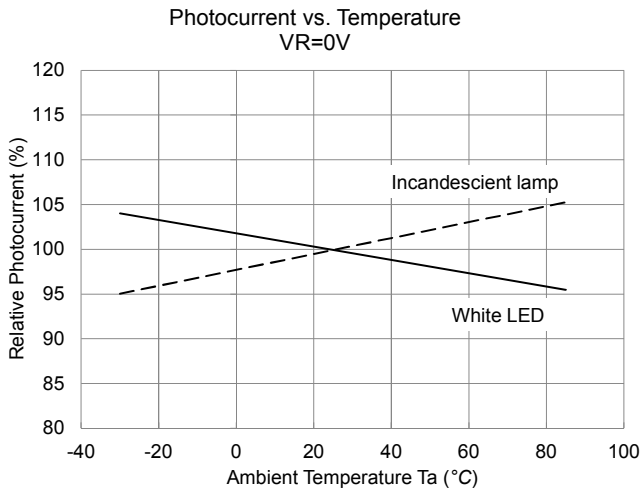
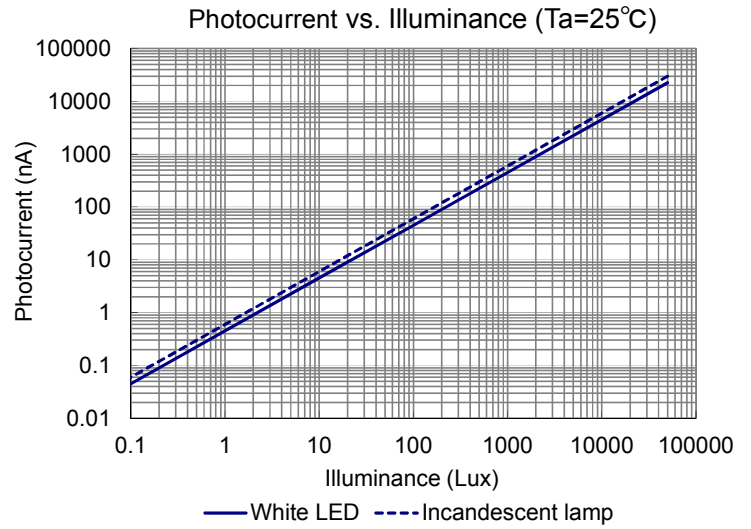
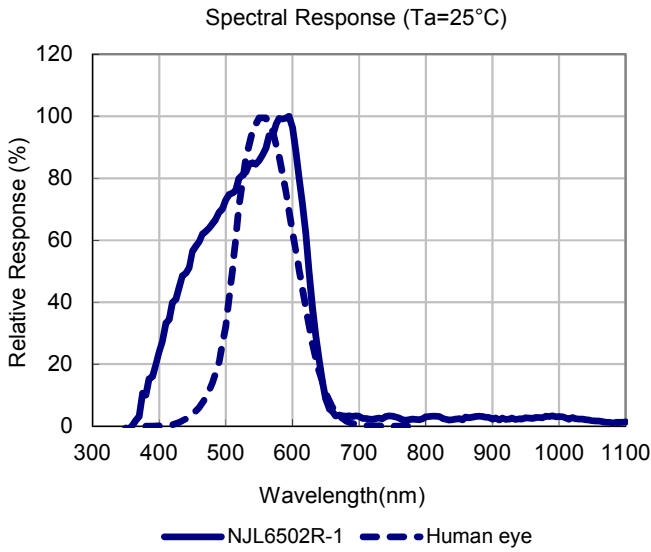

■ MOUNTING METHOD

NOTE

Mounting was evaluated with the following profiles in our company, so there was no problem. However, confirm mounting by the condition of your company beforehand.

The exposure of device under higher temperature many affect to the reliability of the products, it is recommended to complete soldering in the shortest time possible.

Mounting: Twice soldering is allowed.

■ INFRARED REFLOW SOLDERING METHOD

Recommended reflow soldering procedure

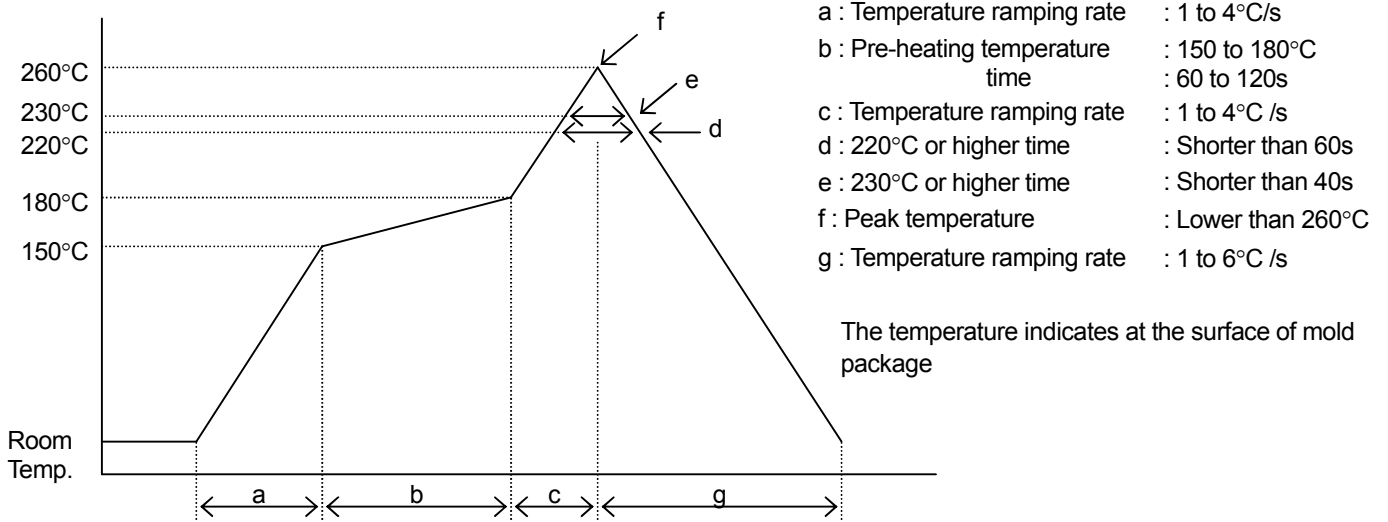

(NOTE1) Using reflow furnace with short wave infrared radiation heater such as halogen lamp

Regarding temperature profile, please refer to those fo reflow furnace.

In this case the resin surface temperature may become higher than lead terminals due to endothermic ally of black colored mold resin. Therefore, please avoid from direct exposure to mold resin.

(NOTE2) Other method

Such other methods of soldering as dipping the device into melted solder and vapor phase method (VPS) are not appropriate because the body of device will be heated rapidly. Therefore, these are not recommended to apply.

(NOTE3) The resin gets softened right after soldering, so, the following care has to be taken

Not to contact the lens surface to anything.

Not to dip the device into water or any solvents.

■ FLOE SOLDERING METHOD

Flow soldering is not possible.

■ IRON SOLDERING METHOD

Iron soldering is not possible.

■ CLEANING

Avoid washing the device after soldering by reflow method.

■ IC STORAGE CONDITIONS AND ITS DURATION

(1) Temperature and humidity ranges

Pack Sealing	Temperature:	5 to 40 [°C]
	Humidity:	40 to 80 [%]
Pack Opening	Temperature:	5 to 30 [°C]
	Humidity:	40 to 70 [%]

After opening the bag, solder products within 48 hours.

Avoid a dry environment below 40% because the products are easily damageable by the electrical discharge.

Store the products in the place where it does not create dew with the products due to a sudden change in temperature.

(2) When baking, place the reel vertically to avoid load to the side.

(3) Do not store the devices in corrosive-gas atmosphere.

(4) Do not store the devices in a dusty place.

(5) Do not expose the devices to direct rays of the sun.

(6) Do not allow external forces or loads to be applied to IC's.

(7) Be careful because affixed label on the reel might be peeled off when baking.

(8) The product is recommended to do the baking before using for the stability of the quality.

■ BAKING

In case of keeping expect above condition be sure to apply baking. (Heat-resistant tape)

Baking method: Ta=60°C, 48 to 72h, Three times baking is allowed
 Ta=100°C, 2 to 6h, Three times baking is allowed

■ STORAGE DURATION

Within a year after delivering this device.

For the products stored longer than a year, confirm their terminals and solderability before they are used.

■ Moisture Sensitivity Levels

JEDEC : Level 5

PACKING SPECIFICATION

PACKING DIMENSIONS UNIT : mm

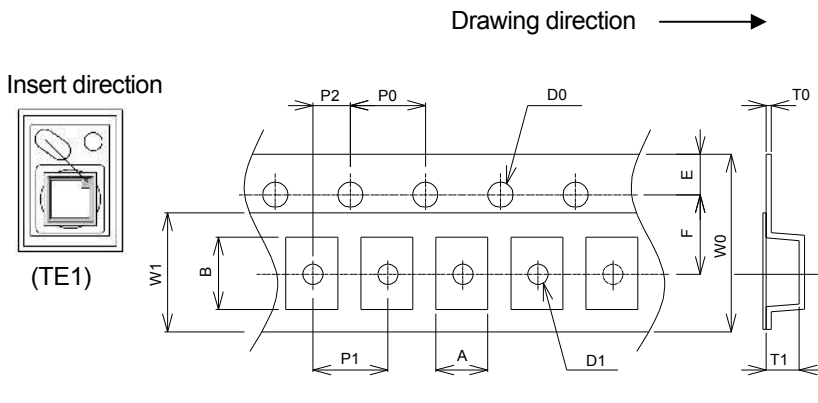

SIMBOL	DIMENSION	REMARKS
A	1.40 ±0.10	BOTOM DIMENSION
B	2.00 ±0.10	BOTOM DIMENSION
D0	1.50 ^{+0.10} _{-0.0}	
D1	1.10 ±0.10	
E	1.75 ±0.10	
F	3.50 ±0.05	
P0	4.00 ±0.10	
P1	4.00 ±0.10	
P2	2.00 ±0.05	
T0	0.25 ±0.05	
T1	1.05 ±0.10	
W0	8.00 ±0.30	
W1	5.40 ±0.10	THICKNESS 0.1MAX

* Carrier tape material : Polycarbonate(antistatic)
Cover tape material : Polyester(antistatic)

Taping Strength

Pull up the cover tape from the carrier tape, and when the opening angle comes around 10 to 15 , and the peeling-off strength is to be within the power of 20 to 40g.

Packaging

- 1) The taped products are to be rolled up on the taping reel as on the drawing.
- 2) Rolling up specification
 - 2-1) Start rolling : Carrier tape open space more than 20 Pieces.
 - 2-2) End of rolling : Carrier tape open space more than 20 Pieces, and 2 round of reel space at the cover tape only.
- 3) Taping quantity : 2,000 Pieces
- 4) Seal off after putting each reels in a damp proof bag with silica gel.

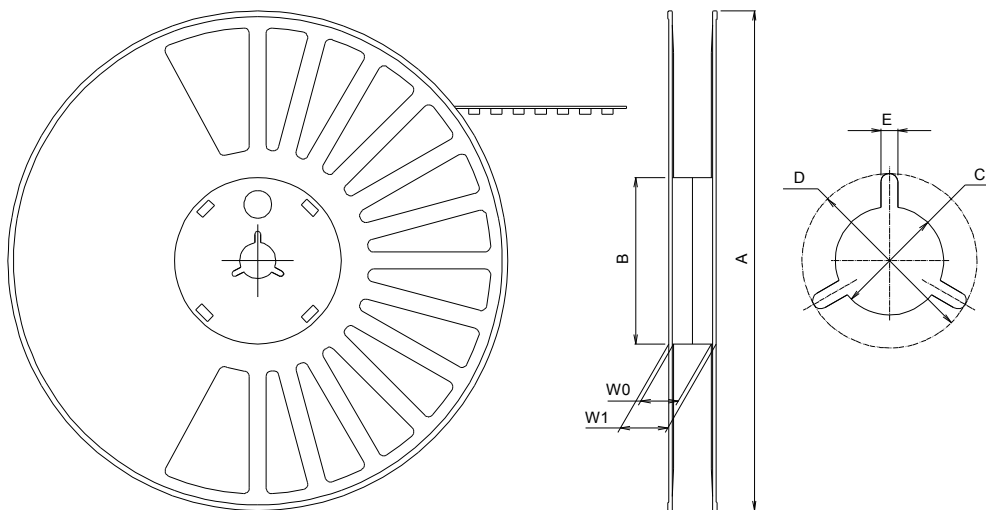

SIMBOL	DIMENSION
A	φ180.0±1.0
B	φ60.0±1.0
C	φ13.0±0.2
D	φ21.0±0.8
E	2.0±0.5
W0	9.5±1.0
W1	13.1±1.0

* Reel material : PPE(antistatic)

[CAUTION]

The specifications on this databook are only given for information , without any guarantee as regards either mistakes or omissions. The application circuits in this databook are described only to show representative usages of the product and not intended for the guarantee or permission of any right including the industrial rights.

Mouser Electronics

Authorized Distributor

Click to View Pricing, Inventory, Delivery & Lifecycle Information:

[NJR:](#)

[NJL6502R-1](#)



Компания «ЭлектроПласт» предлагает заключение долгосрочных отношений при поставках импортных электронных компонентов на взаимовыгодных условиях!

Наши преимущества:

- Оперативные поставки широкого спектра электронных компонентов отечественного и импортного производства напрямую от производителей и с крупнейших мировых складов;
- Поставка более 17-ти миллионов наименований электронных компонентов;
- Поставка сложных, дефицитных, либо снятых с производства позиций;
- Оперативные сроки поставки под заказ (от 5 рабочих дней);
- Экспресс доставка в любую точку России;
- Техническая поддержка проекта, помощь в подборе аналогов, поставка прототипов;
- Система менеджмента качества сертифицирована по Международному стандарту ISO 9001;
- Лицензия ФСБ на осуществление работ с использованием сведений, составляющих государственную тайну;
- Поставка специализированных компонентов (Xilinx, Altera, Analog Devices, Intersil, Interpoint, Microsemi, Aeroflex, Peregrine, Syfer, Eurofarad, Texas Instrument, Miteq, Cobham, E2V, MA-COM, Hittite, Mini-Circuits, General Dynamics и др.);

Помимо этого, одним из направлений компании «ЭлектроПласт» является направление «Источники питания». Мы предлагаем Вам помощь Конструкторского отдела:

- Подбор оптимального решения, техническое обоснование при выборе компонента;
- Подбор аналогов;
- Консультации по применению компонента;
- Поставка образцов и прототипов;
- Техническая поддержка проекта;
- Защита от снятия компонента с производства.



Как с нами связаться

Телефон: 8 (812) 309 58 32 (многоканальный)

Факс: 8 (812) 320-02-42

Электронная почта: org@eplast1.ru

Адрес: 198099, г. Санкт-Петербург, ул. Калинина, дом 2, корпус 4, литера А.