

**LOW VOLTAGE (1.24V) ADJUSTABLE PRECISION SHUNT REGULATOR** **AZ431L**

**General Description**

The AZ431L series ICs are low voltage three-terminal adjustable regulators with guaranteed thermal stability over a full operation range. These ICs feature sharp turn-on characteristics, low temperature coefficient and low output impedance, which make them ideal substitutes for Zener diodes in applications such as switching power supply, charger, motherboard and other adjustable regulators.

The output voltage can be set to any value between 1.24V and 18V with two external resistors.

The AZ431L precision reference is offered in two voltage tolerance: 0.5% and 1.0%.

These ICs are available in 4 packages: TO-92 (bulk or ammo packing), SOT-23, SOT-23-5 and SOT-89.

**Features**

- Wide Programmable Precise Output Voltage from 1.24V to 18V
- High Stability under Capacitive Load
- Low Temperature Deviation: 3mV Typical
- Low Equivalent Full-range Temperature Coefficient: 20PPM/°C Typical
- Low Dynamic Output Resistance: 0.05Ω Typical
- High Sink Current Capacity from 0.1mA to 100mA
- Low Output Noise
- Wide Operating Range of -40 to 125°C

**Applications**

- Graphic Card
- PC Motherboard
- Voltage Adapter
- Switching Power Supply
- Charger

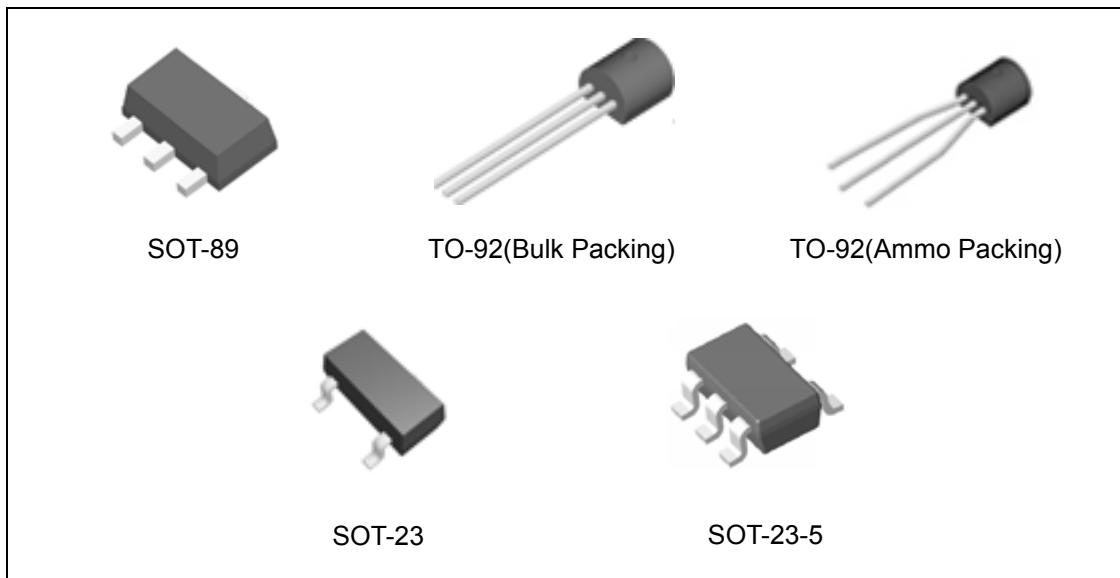
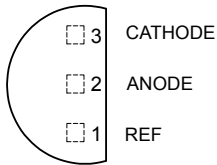

Figure 1. Package Types of AZ431L

**Pin Configuration**

Z Package  
(TO-92(Bulk Packing))



Z Package  
(TO-92(Ammo Packing))

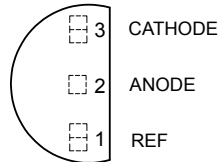

N Package  
(SOT-23)

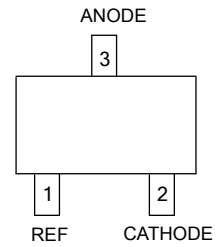

K Package  
(SOT-23-5)

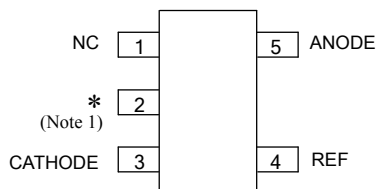

Note 1: \* Pin 2 is attached to substrate and must be connected to ANODE or open

R Package  
(SOT-89)

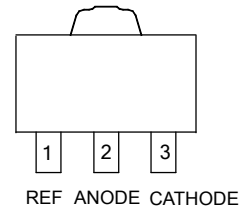

Figure 2. Pin Configuration of AZ431L (Top View)

**Functional Block Diagram**

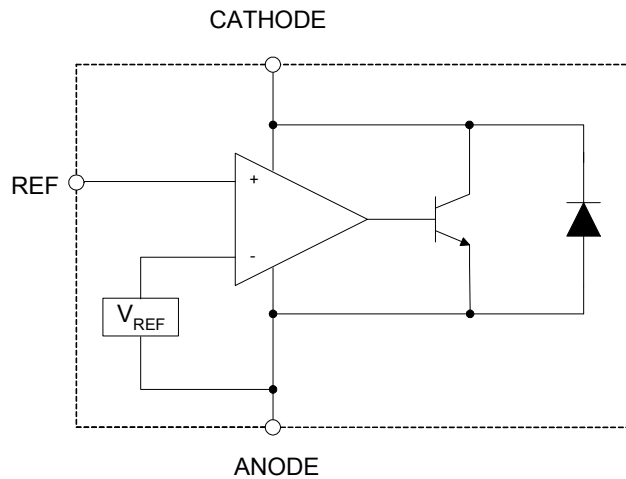
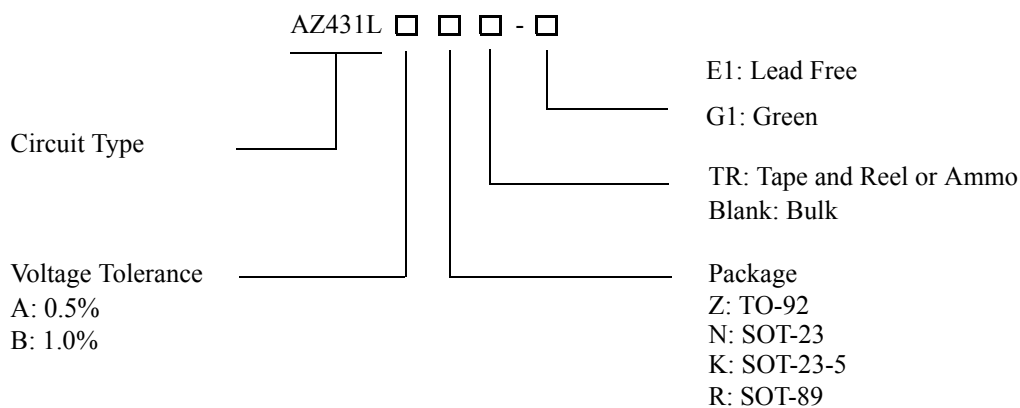

Figure 3. Functional Block Diagram of AZ431L



**LOW VOLTAGE (1.24V) ADJUSTABLE PRECISION SHUNT REGULATOR AZ431L**

**Ordering Information**



Package	Temperature Range	Voltage Tolerance	Part Number		Marking ID		Packing Type
			Lead Free	Green	Lead Free	Green	
TO-92	-40 to 125°C	0.5%	AZ431LAZ-E1	AZ431LAZ-G1	AZ431LAZ-E1	AZ431LAZ-G1	Bulk
		0.5%	AZ431LAZTR-E1	AZ431LAZTR-G1	AZ431LAZ-E1	AZ431LAZ-G1	Ammo
		1.0%	AZ431LBZ-E1	AZ431LBZ-G1	AZ431LBZ-E1	AZ431LBZ-G1	Bulk
		1.0%	AZ431LBZTR-E1	AZ431LBZTR-G1	AZ431LBZ-E1	AZ431LBZ-G1	Ammo
SOT-23	-40 to 125°C	0.5%	AZ431LANTR-E1	AZ431LANTR-G1	EA6	GA6	Tape & Reel
		1.0%	AZ431LBNTR-E1	AZ431LBNTR-G1	EA7	GA7	Tape & Reel
SOT-23-5	-40 to 125°C	0.5%	AZ431LAKTR-E1	AZ431LAKTR-G1	E5A	G5A	Tape & Reel
		1.0%	AZ431LBKTR-E1	AZ431LBKTR-G1	E6A	G6A	Tape & Reel
SOT-89	-40 to 125°C	0.5%	AZ431LARTR-E1	AZ431LARTR-G1	E41A	G41A	Tape & Reel
		1.0%	AZ431LBRTR-E1	AZ431LBRTR-G1	E41B	G41B	Tape & Reel

BCD Semiconductor's Pb-free products, as designated with "E1" suffix in the part number, are RoHS compliant. Products with "G1" suffix are available in green packages.

**LOW VOLTAGE (1.24V) ADJUSTABLE PRECISION SHUNT REGULATOR****AZ431L****Absolute Maximum Ratings (Note 2)**

Parameter	Symbol	Value		Unit
Cathode Voltage	$V_{KA}$	20		V
Cathode Current Range (Continuous)	$I_{KA}$	-100 to 100		mA
Reference Input Current Range	$I_{REF}$	10		mA
Power Dissipation	$P_D$	Z, R Package	770	mW
		N, K Package	370	
Junction Temperature	$T_J$	150		°C
Storage Temperature Range	$T_{STG}$	-65 to 150		°C

Note 2: Stresses greater than those listed under "Absolute Maximum Ratings" may cause permanent damage to the device. These are stress ratings only, and functional operation of the device at these or any other conditions beyond those indicated under "Recommended Operating Conditions" is not implied. Exposure to "Absolute Maximum Ratings" for extended periods may affect device reliability.

**Recommended Operating Conditions**

Parameter	Symbol	Min	Max	Unit
Cathode Voltage	$V_{KA}$	$V_{REF}$	18	V
Cathode Current	$I_{KA}$	0.1	100	mA
Operating Ambient Temperature Range		-40	125	°C



**LOW VOLTAGE (1.24V) ADJUSTABLE PRECISION SHUNT REGULATOR**

**AZ431L**

**Electrical Characteristics**

(Operating Conditions:  $T_A=25^{\circ}\text{C}$ , unless otherwise noted.)

Parameter	Test Circuit	Symbol	Conditions	Min	Typ	Max	Unit	
Reference Voltage	0.5%	4	$V_{REF}$	$V_{KA}=V_{REF}, I_{KA}=10\text{mA}$	1.234	1.240	1.246	V
	1.0%				1.228	1.240	1.252	
Deviation of Reference Voltage Over Full Temperature Range	4	$\Delta V_{REF}$	$V_{KA}=V_{REF}$ $I_{KA}=10\text{mA}$	$0^{\circ}\text{C}$ to $70^{\circ}\text{C}$		2	10	mV
				$-40^{\circ}\text{C}$ to $85^{\circ}\text{C}$		3	10	
				$-40^{\circ}\text{C}$ to $125^{\circ}\text{C}$		4	15	
Ratio of Change in $V_{REF}$ to the Change in Cathode Voltage	5	$\frac{\Delta V_{REF}}{\Delta V_{KA}}$	$I_{KA}=10\text{mA}$ , $\Delta V_{KA}:V_{REF}$ to 16V		-0.5	-1.5	mV/V	
Reference Input Current	5	$I_{REF}$	$I_{KA}=10\text{mA}$ , $R1=10\text{K}\Omega$ , $R2=\infty$		0.15	0.4	$\mu\text{A}$	
Deviation of Reference Current Over Full Temperature Range	5	$\Delta I_{REF}$	$I_{KA}=10\text{mA}$ , $R1=10\text{K}\Omega$ , $R2=\infty$ $T_A=-40$ to $125^{\circ}\text{C}$		0.1	0.4	$\mu\text{A}$	
Minimum Cathode Current for Regulation	4	$I_{KA}$ (Min)	$V_{KA}=V_{REF}$		55	80	$\mu\text{A}$	
Off-state Cathode Current	6	$I_{KA}$ (Off)	$V_{REF}=0$ , $V_{KA}=18\text{V}$		0.04	0.10	$\mu\text{A}$	
			$V_{KA}=6$ , $V_{REF}=0$		0.01	0.05		
Dynamic Impedance	4	$Z_{KA}$	$V_{KA}=V_{REF}$ , $I_{KA}=1$ to $100\text{mA}$ $f \leq 1.0\text{kHz}$		0.05	0.15	$\Omega$	
Thermal Resistance		$\theta_{JC}$	SOT-23		84.84		$^{\circ}\text{C}/\text{W}$	
			SOT-23-5		84.84			
			TO-92		140.80			
			SOT-89		29.80			

**Electrical Characteristics (Continued)**



Figure 4. Test Circuit 4 for  $V_{KA} = V_{REF}$

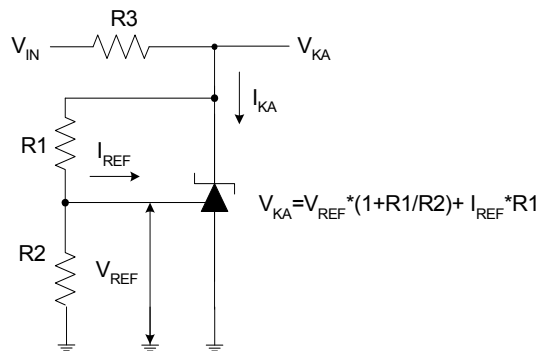

Figure 5. Test Circuit 5 for  $V_{KA} > V_{REF}$

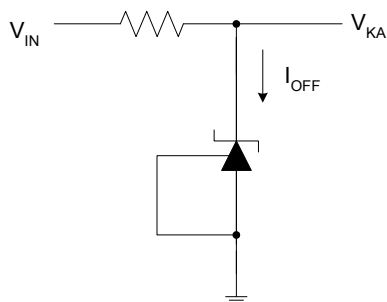

Figure 6. Test Circuit 6 for  $I_{OFF}$



Typical Performance Characteristics

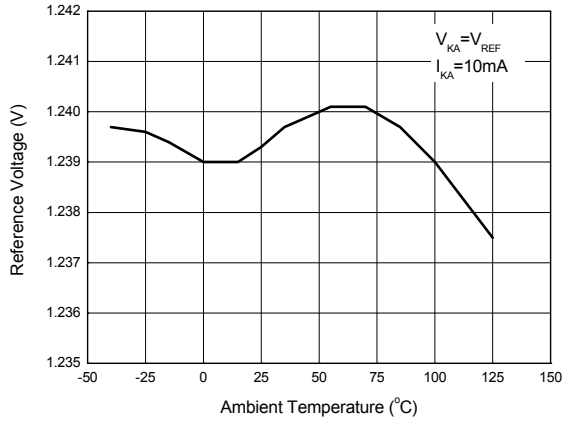

Figure 7. Reference Voltage vs. Ambient Temperature

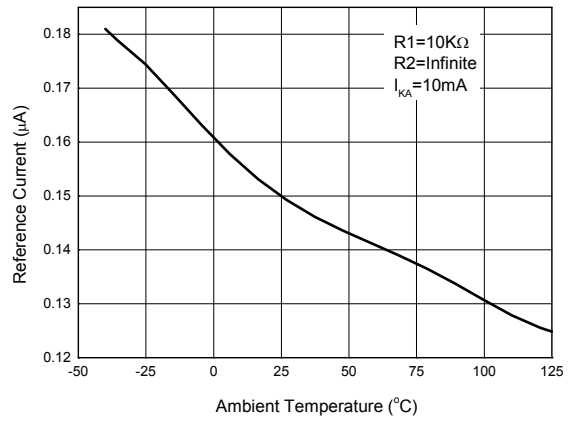

Figure 8. Reference Current vs. Ambient Temperature

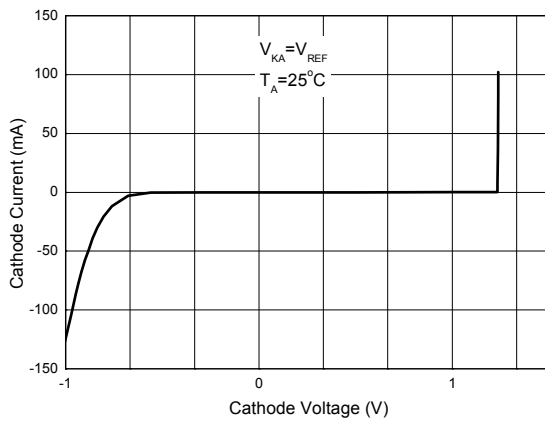

Figure 9. Cathode Current vs. Cathode Voltage

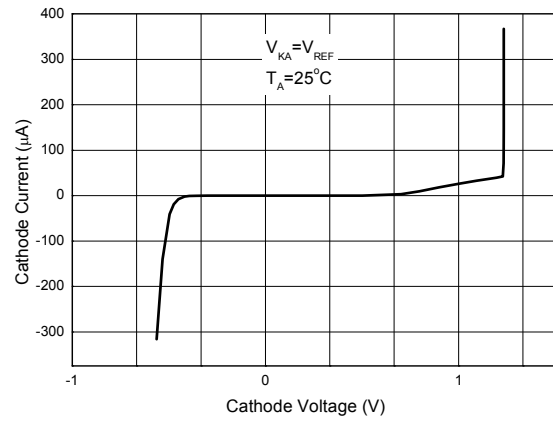

Figure 10. Cathode Current vs. Cathode Voltage

**Typical Performance Characteristics (Continued)**

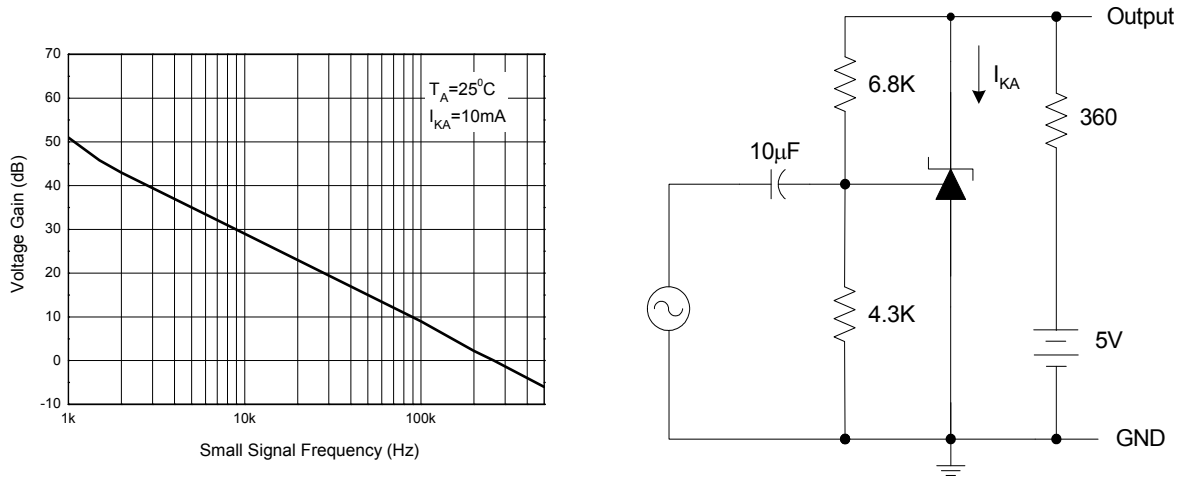

Figure 11. Small Signal Voltage Gain vs. Frequency

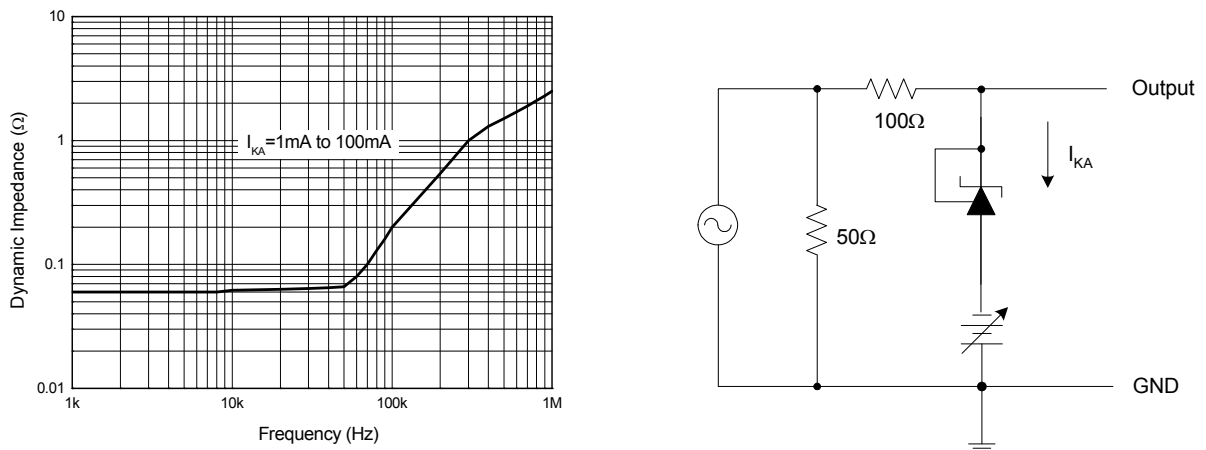

Figure 12. Dynamic Impedance vs. Frequency



**Typical Performance Characteristics (Continued)**

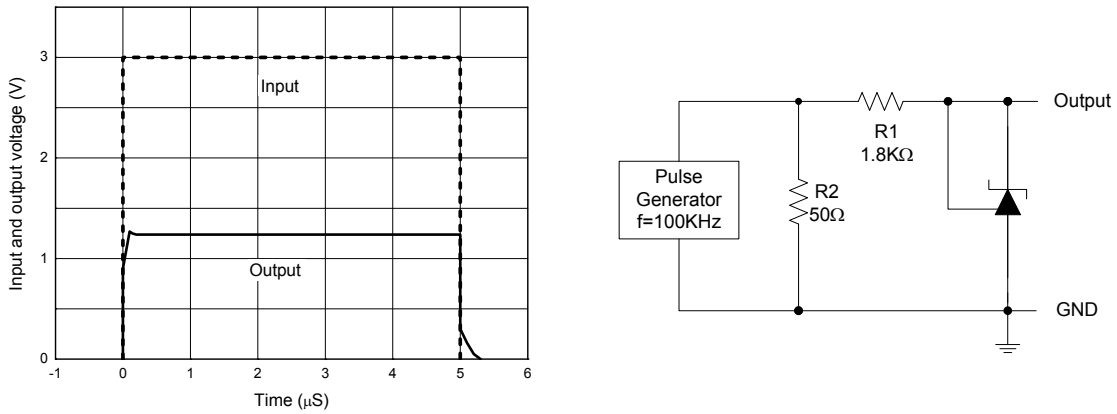

Figure 13. Pulse Response of Input and Output Voltage

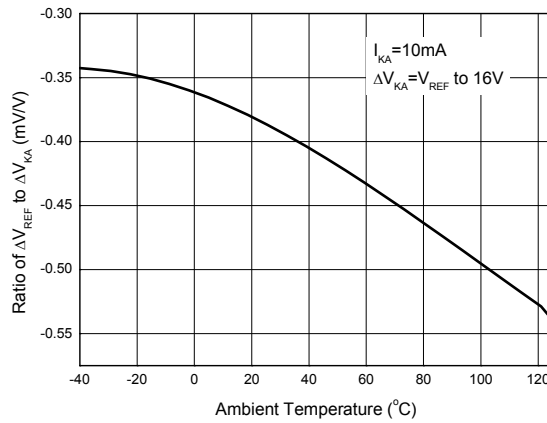

Figure 14. Ratio of Delta Reference Voltage to the Ratio of Cathode Voltage vs. Ambient Temperature

**Typical Applications**

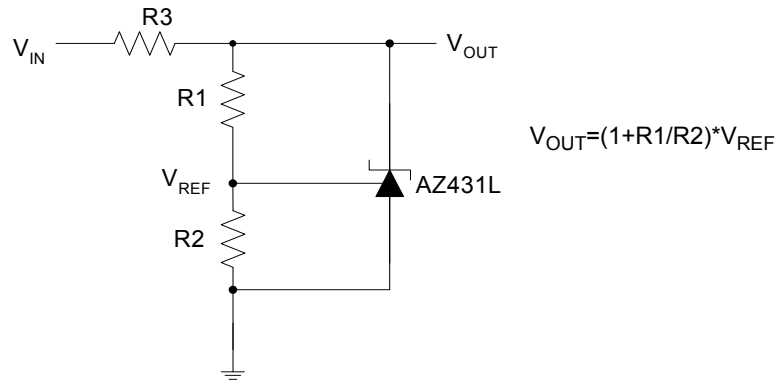

Figure 15. Shunt Regulator

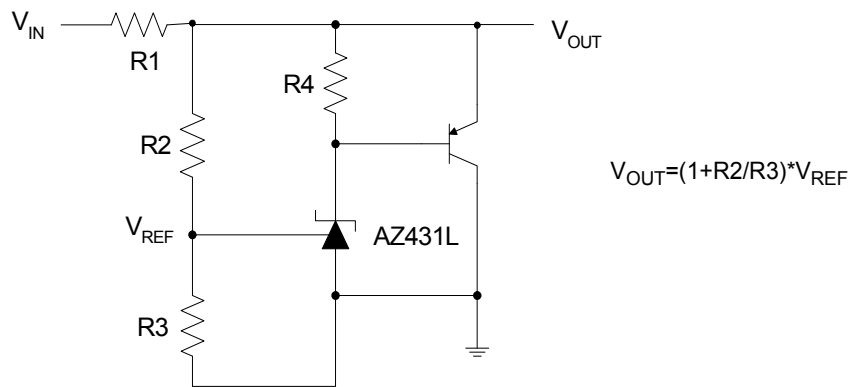

Figure 16. High Current Shunt Regulator

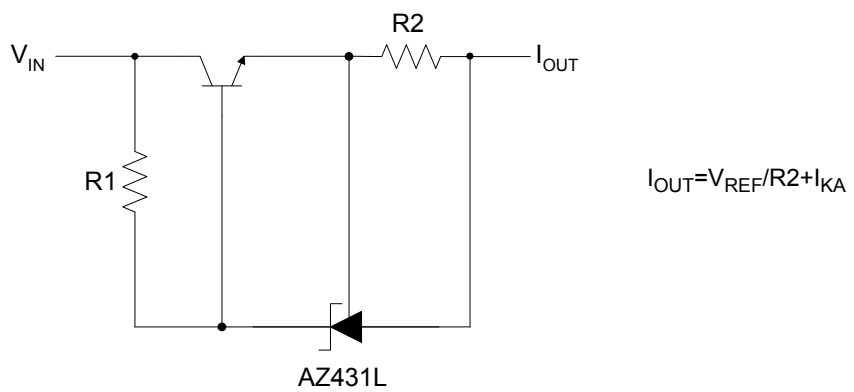

Figure 17. Current Source or Current Limit

**Typical Application (Continued)**

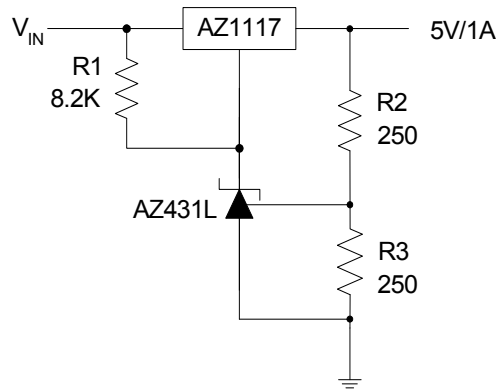

Figure18. Precision 5V 1A Regulator

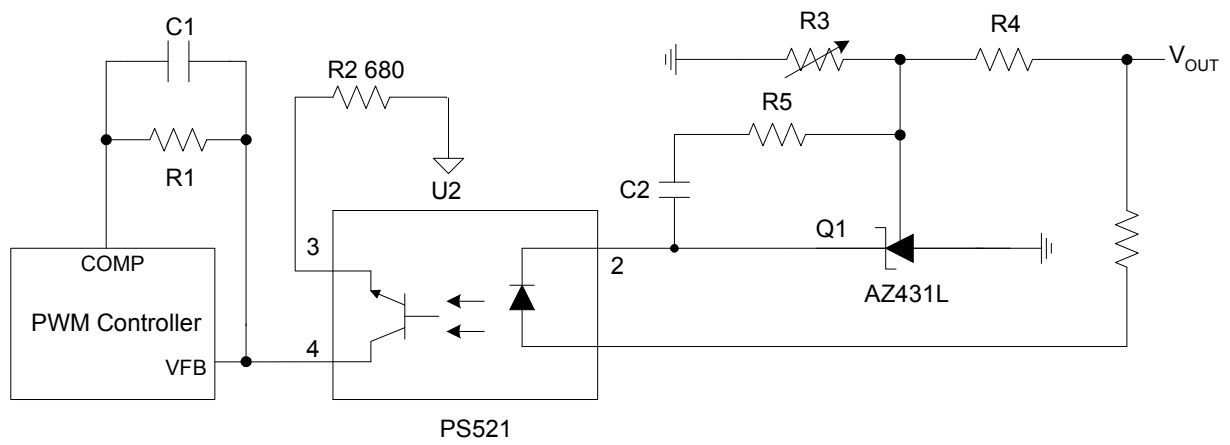

Figure 19. PWM Converter with Reference



Mechanical Dimensions

TO-92(Bulk Packing)

Unit: mm(inch)

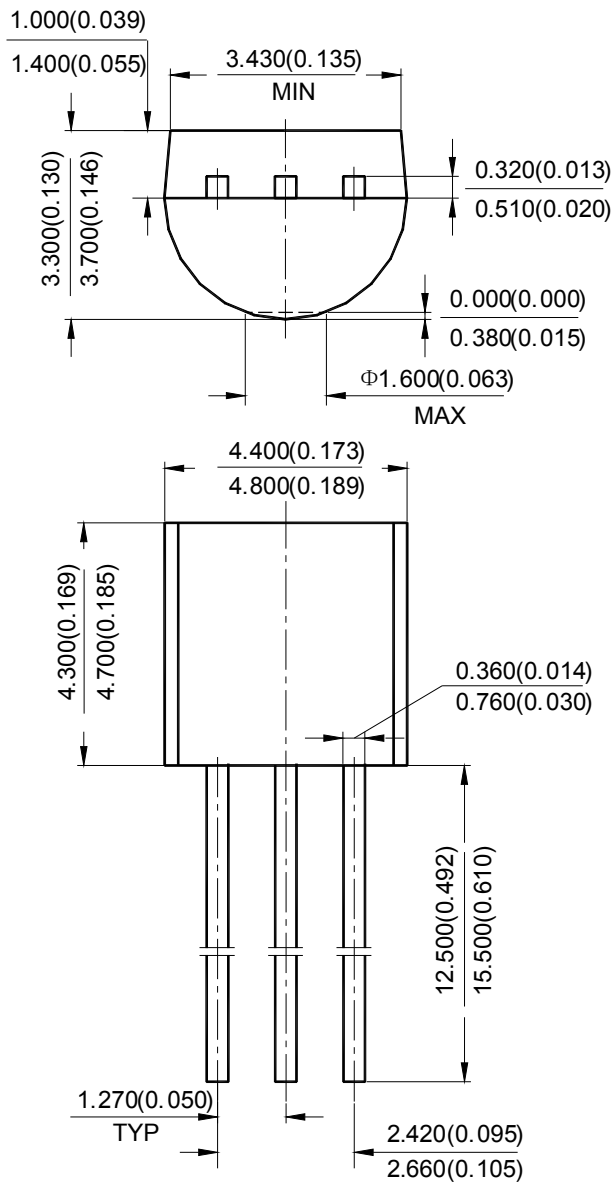



Mechanical Dimensions (Continued)

TO-92(Ammo Packing)

Unit: mm(inch)

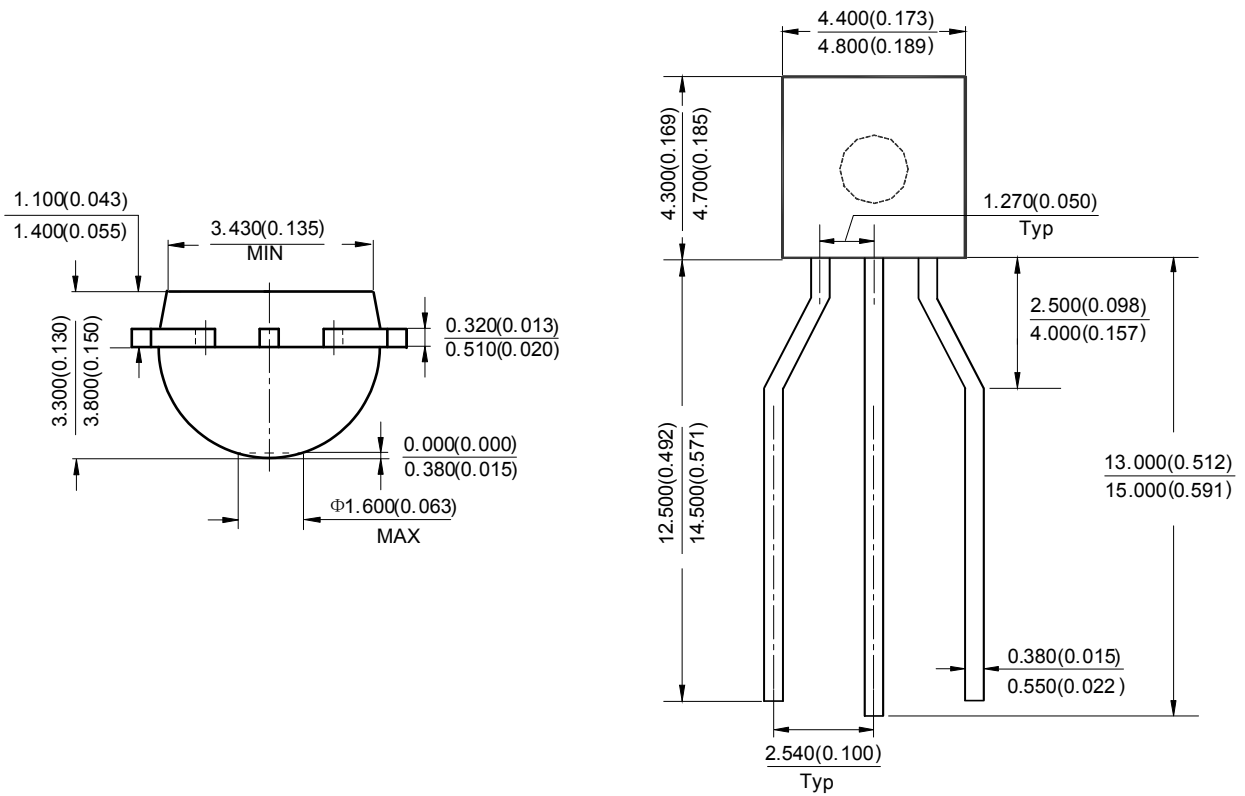



Mechanical Dimensions (Continued)

SOT-23

Unit: mm(inch)

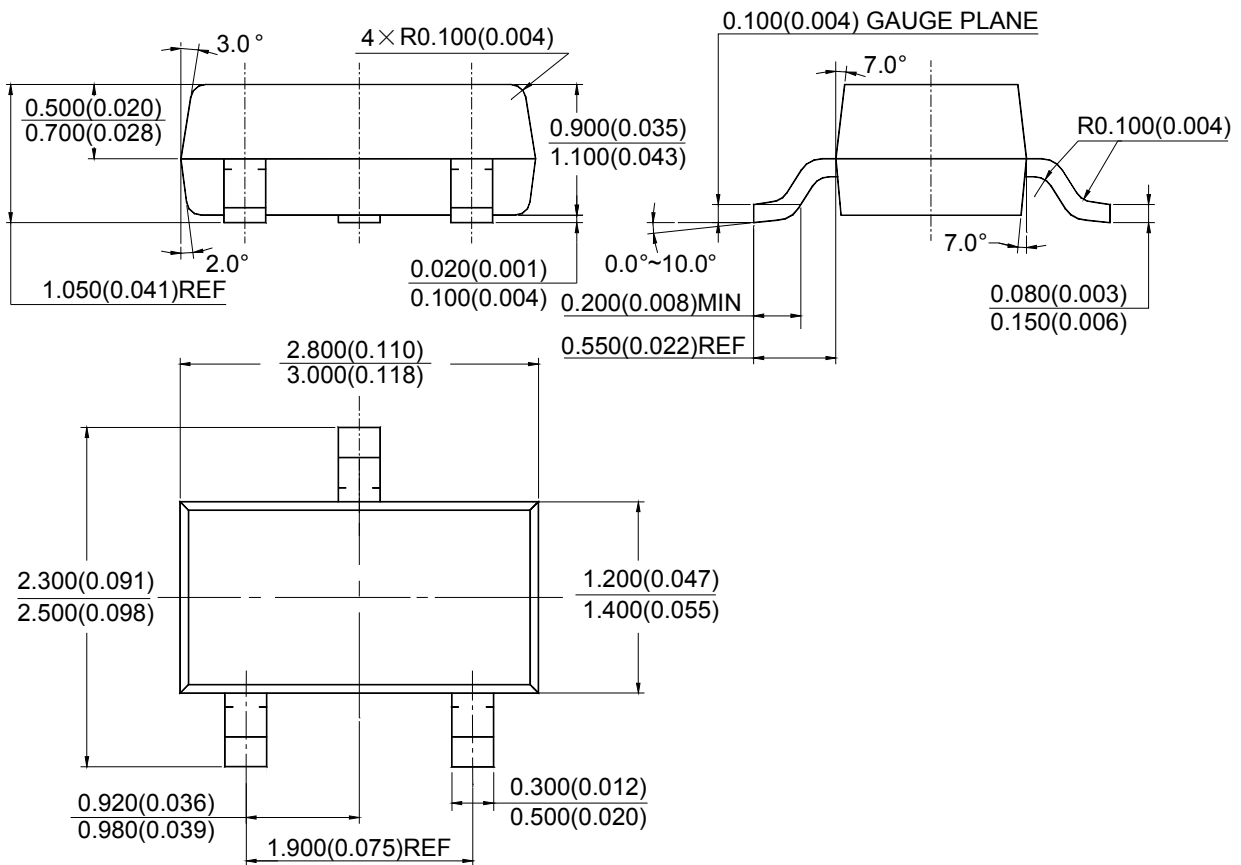



Mechanical Dimensions (Continued)

SOT-23-5

Unit: mm(inch)

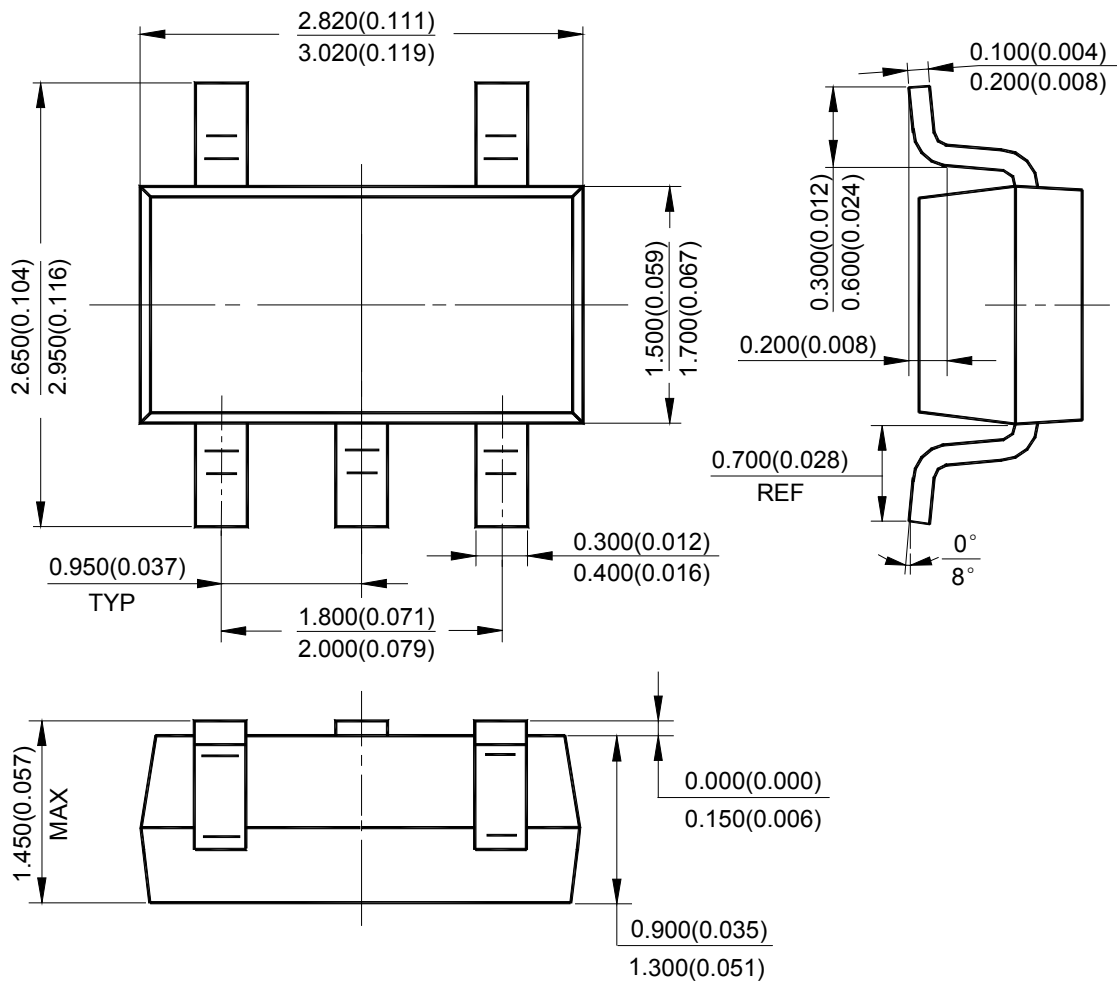



Mechanical Dimensions (Continued)

SOT-89

Unit: mm(inch)

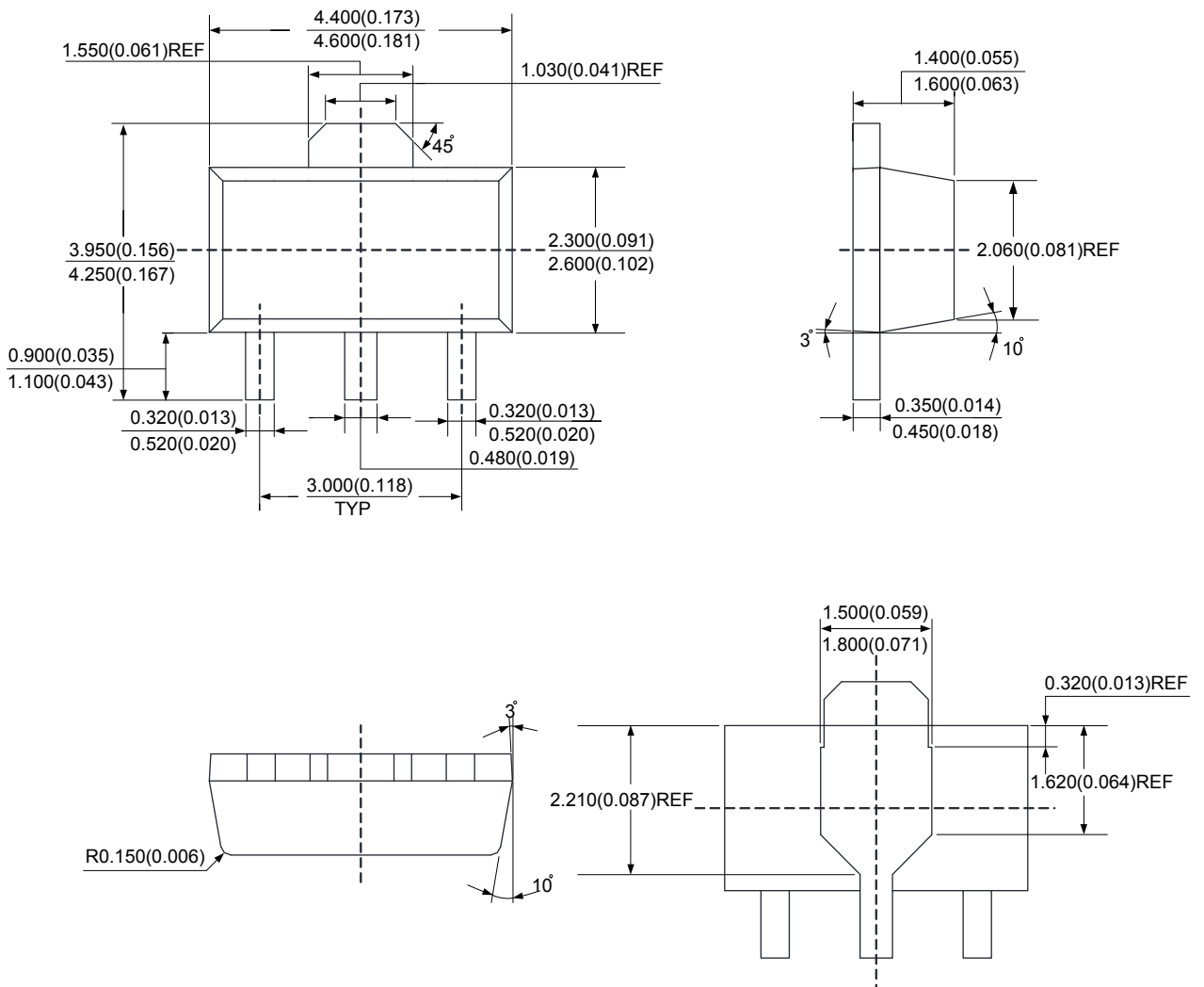





## **BCD Semiconductor Manufacturing Limited**

<http://www.bcdsemi.com>

### **IMPORTANT NOTICE**

BCD Semiconductor Manufacturing Limited reserves the right to make changes without further notice to any products or specifications herein. BCD Semiconductor Manufacturing Limited does not assume any responsibility for use of any its products for any particular purpose, nor does BCD Semiconductor Manufacturing Limited assume any liability arising out of the application or use of any its products or circuits. BCD Semiconductor Manufacturing Limited does not convey any license under its patent rights or other rights nor the rights of others.

---

#### **MAIN SITE**

##### **- Headquarters**

##### **BCD Semiconductor Manufacturing Limited**

No. 1600, Zi Xing Road, Shanghai ZiZhu Science-based Industrial Park, 200241, China  
Tel: +86-21-24162266, Fax: +86-21-24162277

##### **- Wafer Fab**

##### **Shanghai SIM-BCD Semiconductor Manufacturing Co., Ltd.**

800 Yi Shan Road, Shanghai 200233, China  
Tel: +86-21-6485 1491, Fax: +86-21-5450 0008

#### **REGIONAL SALES OFFICE**

##### **Shenzhen Office**

##### **Shanghai SIM-BCD Semiconductor Manufacturing Co., Ltd., Shenzhen Office**

Unit A Room 1203, Skyworth Bldg., Gaoxin Ave. 1.S., Nanshan District, Shenzhen, China  
Tel: +86-755-8826 7951  
Fax: +86-755-8826 7865

##### **Taiwan Office**

##### **BCD Semiconductor (Taiwan) Company Limited**

4F, 298-1, Rui Guang Road, Nei-Hu District, Taipei, Taiwan  
Tel: +886-2-2656 2808  
Fax: +886-2-2656 2806

##### **USA Office**

##### **BCD Semiconductor Corp.**

30920 Huntwood Ave. Hayward, CA 94544, USA  
Tel : +1-510-324-2988  
Fax: +1-510-324-2788



Компания «ЭлектроПласт» предлагает заключение долгосрочных отношений при поставках импортных электронных компонентов на взаимовыгодных условиях!

Наши преимущества:

- Оперативные поставки широкого спектра электронных компонентов отечественного и импортного производства напрямую от производителей и с крупнейших мировых складов;
- Поставка более 17-ти миллионов наименований электронных компонентов;
- Поставка сложных, дефицитных, либо снятых с производства позиций;
- Оперативные сроки поставки под заказ (от 5 рабочих дней);
- Экспресс доставка в любую точку России;
- Техническая поддержка проекта, помощь в подборе аналогов, поставка прототипов;
- Система менеджмента качества сертифицирована по Международному стандарту ISO 9001;
- Лицензия ФСБ на осуществление работ с использованием сведений, составляющих государственную тайну;
- Поставка специализированных компонентов (Xilinx, Altera, Analog Devices, Intersil, Interpoint, Microsemi, Aeroflex, Peregrine, Syfer, Eurofarad, Texas Instrument, Miteq, Cobham, E2V, MA-COM, Hittite, Mini-Circuits, General Dynamics и др.);

Помимо этого, одним из направлений компании «ЭлектроПласт» является направление «Источники питания». Мы предлагаем Вам помощь Конструкторского отдела:

- Подбор оптимального решения, техническое обоснование при выборе компонента;
- Подбор аналогов;
- Консультации по применению компонента;
- Поставка образцов и прототипов;
- Техническая поддержка проекта;
- Защита от снятия компонента с производства.



#### Как с нами связаться

**Телефон:** 8 (812) 309 58 32 (многоканальный)

**Факс:** 8 (812) 320-02-42

**Электронная почта:** [org@eplast1.ru](mailto:org@eplast1.ru)

**Адрес:** 198099, г. Санкт-Петербург, ул. Калинина, дом 2, корпус 4, литера А.