

USB Pro Gateways



General Description

The ALTA USB Pro gateway allows your Monnit Wireless Sensors to communicate with the iMonnit™ online wireless sensor monitoring and notification system or Monnit Express™ standalone PC software. Simply plug the device into an available USB port on a Microsoft Windows PC.

If the PC has an active internet connection and you wish to use it with the iMonnit online software, install the Monnit Gateway application to pass sensor data to the online system. If you wish to use your wireless sensors locally (collect and store sensor data on your PC), install the Monnit Express standalone software and all sensor data will be stored within the software's database. The Monnit Express software allows you to export sensor data in a .csv format spreadsheet, and is also capable of sending SMS text and email alerts if the host computer has an active Internet connection.

With the online iMonnit software, you can easily configure your network, view collected sensor data and set alarms through SMS or e-mail, all from any web enabled browser. The system allows for complete configuration and customization at a sensor, local network, or client wide level.

The ALTA USB Pro gateway is specifically designed to respond to the increasing market need for global technology that accommodates a variety of vertical M2M application segments and remote wireless sensor management solutions.

Enjoy reliable, low cost, wireless monitoring of your facilities or specific applications, with Monnit wireless sensor networks.

ALTA USB Pro Gateway Features

- Wireless range of 1,000+ feet through 12-14 walls *
- Frequency Hopping Spread Spectrum (FHSS)
- Improved interference immunity
- Encrypt-RF™ Security (Diffie-Hellman Key Exchange + AES-128 CBC for sensor data messages)
- 16,000 sensor message memory
- Over the air updates (future proof)
- Optional RS232 DB9 communication port
- USB, RS232, or external power options
- Can be used with both iMonnit Online Software or Monnit Express Standalone PC Software
- Uses standard FTDI driver so no driver installation required
- External USB cable allows gateway to be positioned for improved communication range
- Programmable heart-beat control
- Supports up to 100 wireless sensors per USB
- Windows 10, 8, 7, and Vista compatible

* Actual range may vary depending on environment.

Wireless Range Comparison

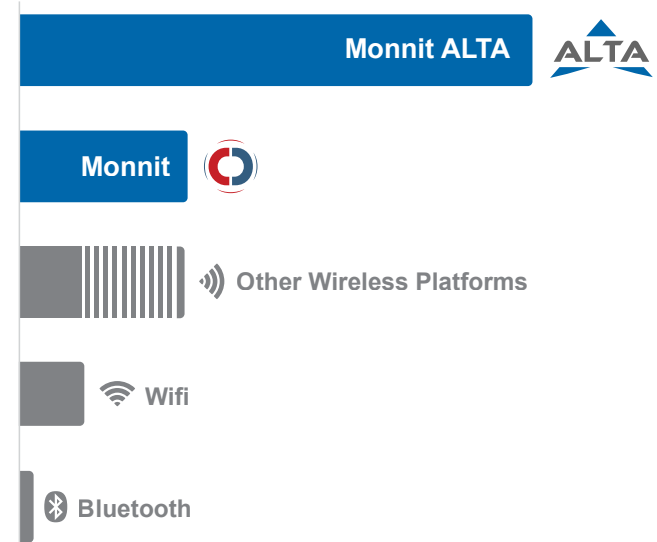

ALTA USB Pro Gateway Dimensions

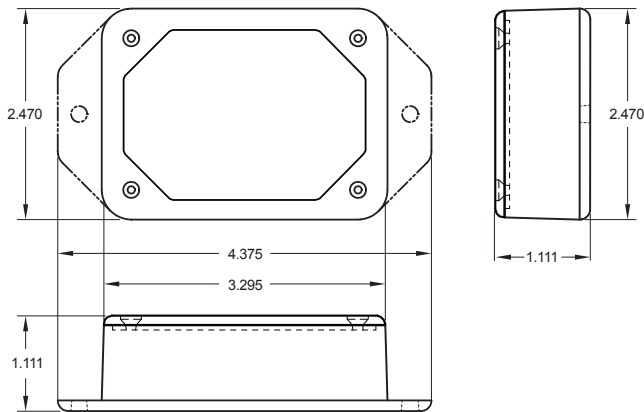

Example Applications

- Facilities / Building Operations
- Restaurants / Food Service
- Server Rooms / Data Closets
- Pharmaceutical / Labs
- Heating and Cooling
- Agriculture Monitoring
- And many more...

Monnit USB Pro Gateway Specifications

USB

Type:	USB 2.0 Full Speed Bus Standard
Display Name:	Monnit USB Radio Gateway
Display Type:	MonnitApnClass
Software Version:	3.4.0.2 or later
Software Compatible Platforms:	Microsoft Windows 10, 8, 7 or Vista required. (Windows XP and older are not supported.)
Bus Reported Device Description:	M+ LINK
Memory Capacity:	14,336 up messages (to gateway/server) 2,048 down messages (to sensors)
RS232 (Optional)	115200 baudrate, 8 data bits, no parity, 1 stop bit, DB9 connector

Power

Power	Powered through USB output of PC (Optional) External Power (Optional) RS232 Power Pin 4 (Optional) RS232 Power Pin 8
Maximum Power Required:	100 mA

Mechanical

Enclosure	ABS plastic
Dimensions	4.357 x 2.47 x 1.12 Inches
Weight	4 ounces

Environmental

Operating Temperature	-40 to +85 °C
-----------------------	---------------

Wireless

Wireless Range	1,000+ ft. non-line-of-sight ***
Security	Encrypt-RF™ (256-bit key exchange and AES-128 CTR)
Certifications	 900 MHz product; FCC ID: ZTL- G2SC1 and IC: 9794A-G2SC1.

* Hardware cannot withstand negative voltage. Please take care when connecting a power device.

** At temperatures above 100°C, it is possible for the board circuitry to lose programmed memory.

*** Actual range may vary depending on environment.

Caution / Notice:

Monnit commercial grade products are designed for applications in ordinary environments (normal room temperature, humidity and atmospheric pressure). Do not use these sensors under the following conditions as these factors can deteriorate the product characteristics and cause failures and burn-out.

- Corrosive gas or deoxidizing gas - chlorine gas, hydrogen sulfide gas, ammonia gas, sulfuric acid gas, nitric oxides gas, etc.).
- Volatile or flammable gas.
- Dusty conditions.
- Under low or high pressure.
- Wet or excessively humid locations.
- Places with salt water, oils chemical liquids or organic solvents.
- Where there are excessively strong vibrations.
- Other places where similar hazardous conditions exist.

Use these product within the specified temperature range. Higher temperature may cause deterioration of the characteristics or the material quality of this product.



For more information about our products or to place an order, please contact our sales department at 801-561-5555.

Visit us on the web at www.monnit.com.

Monnit Corporation
3400 South West Temple
South Salt Lake, UT 84115
801-561-5555
www.monnit.com



Компания «ЭлектроПласт» предлагает заключение долгосрочных отношений при поставках импортных электронных компонентов на взаимовыгодных условиях!

Наши преимущества:

- Оперативные поставки широкого спектра электронных компонентов отечественного и импортного производства напрямую от производителей и с крупнейших мировых складов;
- Поставка более 17-ти миллионов наименований электронных компонентов;
- Поставка сложных, дефицитных, либо снятых с производства позиций;
- Оперативные сроки поставки под заказ (от 5 рабочих дней);
- Экспресс доставка в любую точку России;
- Техническая поддержка проекта, помощь в подборе аналогов, поставка прототипов;
- Система менеджмента качества сертифицирована по Международному стандарту ISO 9001;
- Лицензия ФСБ на осуществление работ с использованием сведений, составляющих государственную тайну;
- Поставка специализированных компонентов (Xilinx, Altera, Analog Devices, Intersil, Interpoint, Microsemi, Aeroflex, Peregrine, Syfer, Eurofarad, Texas Instrument, Miteq, Cobham, E2V, MA-COM, Hittite, Mini-Circuits, General Dynamics и др.);

Помимо этого, одним из направлений компании «ЭлектроПласт» является направление «Источники питания». Мы предлагаем Вам помощь Конструкторского отдела:

- Подбор оптимального решения, техническое обоснование при выборе компонента;
- Подбор аналогов;
- Консультации по применению компонента;
- Поставка образцов и прототипов;
- Техническая поддержка проекта;
- Защита от снятия компонента с производства.



Как с нами связаться

Телефон: 8 (812) 309 58 32 (многоканальный)

Факс: 8 (812) 320-02-42

Электронная почта: org@eplast1.ru

Адрес: 198099, г. Санкт-Петербург, ул. Калинина, дом 2, корпус 4, литера А.