

3M™ FOUR-WALL HEADER, 3000 SERIES

.100" X .100" LATCH/EJECTOR, STRAIGHT AND RIGHT ANGLE

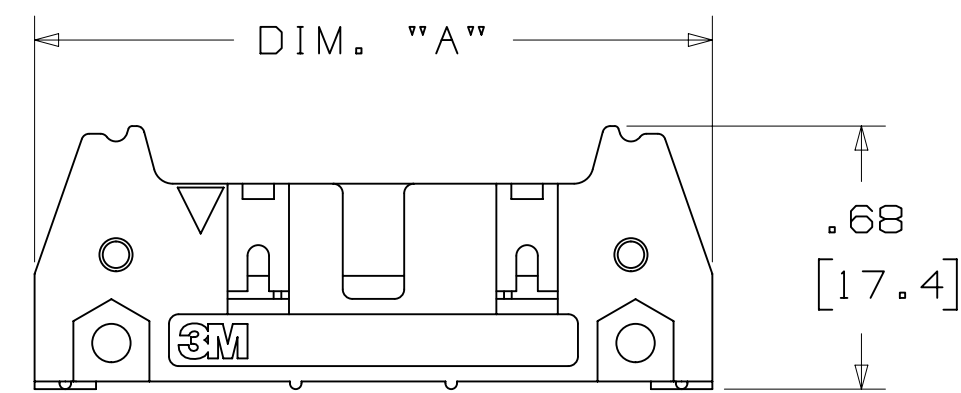

-X0XX
HEADER WITHOUT LATCH/EJECTOR

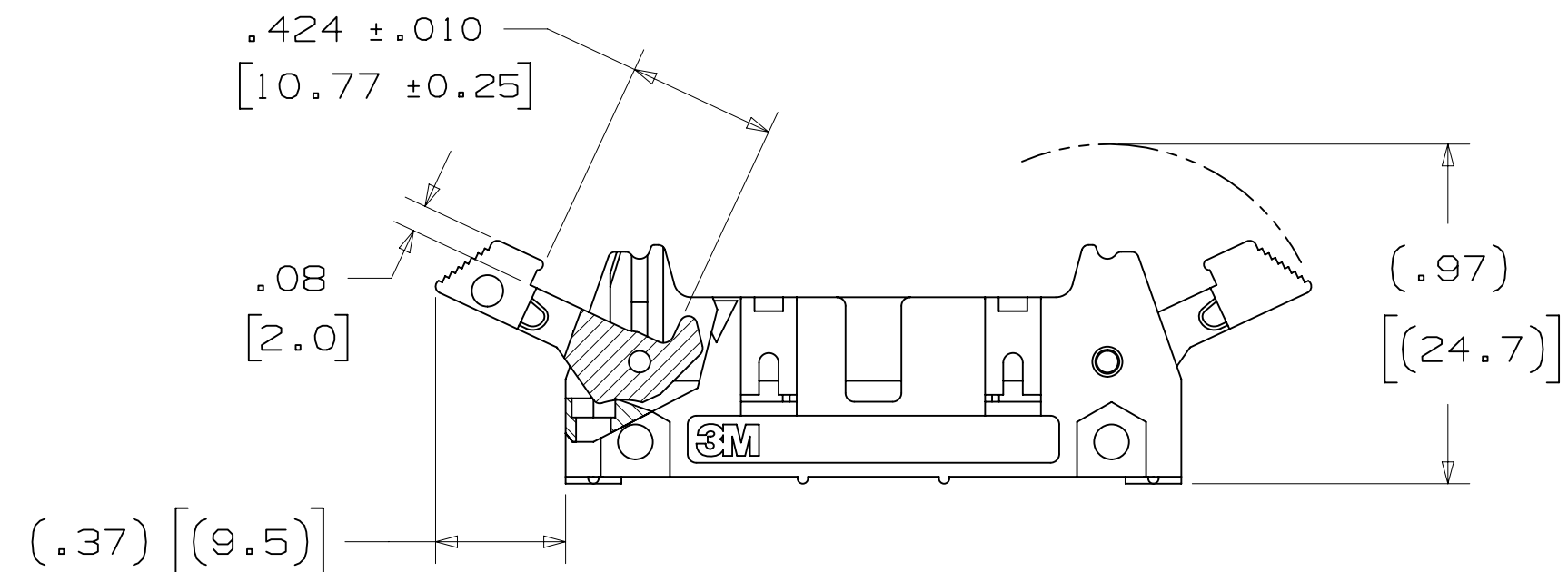

-X2XX
HEADER WITH SHORT LATCH/EJECTOR
FOR 3M SOCKETS WITHOUT STRAIN RELIEF

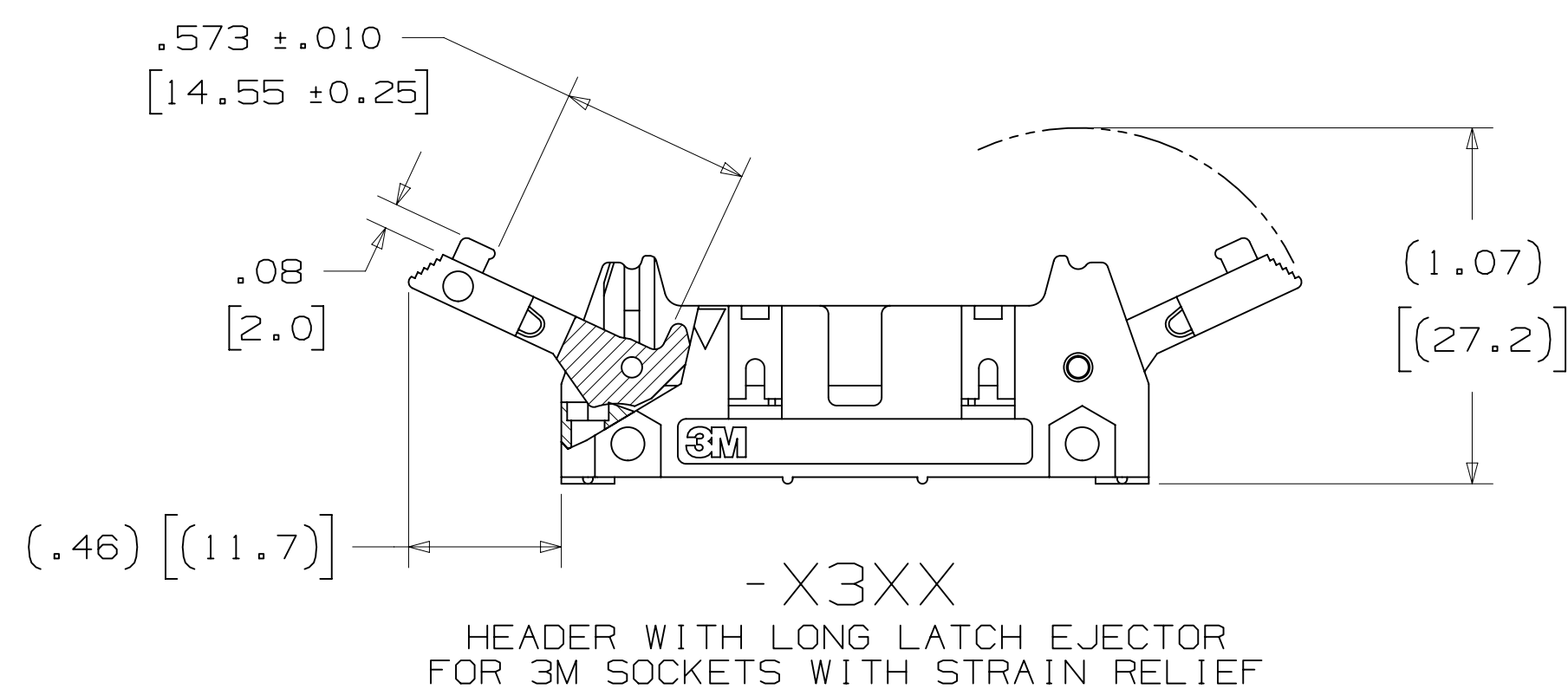

-X3XX
HEADER WITH LONG LATCH/EJECTOR
FOR 3M SOCKETS WITH STRAIN RELIEF

- * MILITARY (WITH 3M'S N3518 POLARIZING KEY) AND CENTERBUMP POLARIZATION.
- * OPTIONAL EJECTOR LATCHES.
- * MOUNTING HOLES FOR SECURING HEADER TO BOARD.
- * OPTIONAL POLARIZING POSTS AVAILABLE.
- * HIGH TEMPERATURE INSULATOR SUITABLE FOR "NO LEAD" SOLDERING OPERATIONS.
- * SUITABLE FOR REFLOW SOLDERING USING "PASTE IN HOLE" TECHNIQUES.
- * SOLDER TAIL OPTION.

2 PHYSICAL :

INSULATOR: GLASS FILLED POLYESTER (PCT)
 MATERIAL: UL94V-0
 FLAMMABILITY: UL94V-0
 COLOR: BLACK
 CONTACT: COPPER ALLOY
 PLATING: 100µ" [2.54µm] AVG. NICKEL-OVERALL
 UNDER PLATING: 30µ" [0.76µm] AVG. GOLD
 WIPING AREA: TIN LEAD OR MATTE TIN (SEE ORDERING INFORMATION)
 MARKINGS: 3M LOGO, PART IDENTIFICATION NUMBER AND ORIENTATION TRIANGLE

2 ELECTRICAL :

EIA CURRENT RATING: 5.00A, 1 CONTACT POWERED
 3.00A, 6 CONTACTS POWERED
 1.75A, ALL CONTACTS POWERED
 RATING CONDITIONS: EIA-364-070 METHOD 2, 30°C MAXIMUM TEMPERATURE RISE, 20% DERATED. REFERENCE APPROPRIATE 3M PRODUCT SPECIFICATION FOR DETAILED CURRENT DERATING CURVES.
 INSULATION RESISTANCE: >1 X 10⁹Ω AT 500 V_{DC}
 WITHSTANDING VOLTAGE: 1,000V_{RMS} AT SEA LEVEL
 UL CURRENT RATING: 1.0A ALL LINES POWERED
 UL VOLTAGE RATING: 125V

2 ENVIRONMENTAL :

UL TEMPERATURE RATING: 130C
 EIA TEMPERATURE RATING: -55°C TO 105°C
 PROCESS RATING: 260°C, PER J-STD-020C, SINGLE PASS
 MOISTURE SENSITIVITY LEVEL: 1 (PER J-STD-020C)

- NOTES
1. REGULATORY INFORMATION: ROHS COMPLIANT. SEE THE REGULATORY INFORMATION APPENDIX (RIA) IN THE "ROHS COMPLIANCE" SECTION OF WWW.3MCONNECTORS.COM FOR COMPLIANCE INFORMATION.
 2. IN THE EVENT OF CONFLICT BETWEEN THIS DATA AND THAT CONTAINED IN THE PRODUCT SPECIFICATION, THE PRODUCT SPECIFICATION TAKES PRECEDENT.
 3. NOTCHES A & C WILL ACCOMODATE 3M POLARIZING KEY: N3518.
 4. MOUNTING HARDWARE: FROM SOLDER SIDE OF PC BOARD USE #4-24 THREAD CUTTING SCREW (3M PART #3341-5) WITH Ø.116 [2.95] MOUNTING HOLE. FOR RIGHT ANGLE VERSION ONLY: #2-56 BOLT AND NUT (3M PART #3341-6) WITH Ø.106 [2.69] MOUNTING HOLE MAY BE USED.
 5. THE RECOMMENDED PCB HOLE SIZE FOR THE KINKED TAIL POSITIONS ON THE .112 SOLDER TAIL CONNECTOR IS Ø.035±.002. (SEE K2 VERSION).

ORDERING INFORMATION

X3XXX-XXXXXX

N= HIGH TEMP BLACK (PCT)/(RB PLATING REQ'D)
 BLANK= STANDARD TEMP (UB AND EB PLATING)

3M PART NUMBER:
(SEE TABLE 1)

PIN CONFIGURATION:
 5 = RIGHT ANGLE SOLDER TAILS
 6 = STRAIGHT SOLDER TAILS

PLATING:

RB = 200µ" [5.08µm] MATTE TIN TAILS (APP. E1 & C1 APPLY)
 UB OR BLANK, STANDARD TEMP ONLY = 200µ" [5.08µm] TIN LEAD TAILS (APP. E3 & C2 APPLY)
 EB OR BLANK, WWT TAIL OPTION 05 ONLY = FLASH GOLD TAIL (APP.E1 & C1 APPLY)

TAIL:

02 = FOR .062 [1.57] THICK BOARD
 03 = FOR .094 TO .125 [2.39 TO 3.18] THICK BOARD
 05 = WWT FOR UP TO 3 LEVELS OF WIRE WRAP
 K2 = KINKED FOR .062 [1.57] THICK BOARD

LATCH/EJECTOR SYSTEM:

0 = NO LATCH/EJECTOR INSTALLED
 2 = SHORT ROLL PIN LATCH/EJECTORS
 3 = LONG ROLL PIN LATCH/EJECTORS

DIMENSIONS: INCHES [MM]
 [MM] IS REF. ONLY

3M ELECTRONIC MATERIALS SOLUTIONS DIVISION
 INTERCONNECT SOLUTIONS
<http://www.3mconnectors.com>

3M IS A TRADEMARK OF 3M COMPANY.
 FOR TECHNICAL, SALES OR ORDERING
 INFORMATION CALL 800-225-5373

3M
 UL FILE NO: E68080

DESIGN REFERENCE	NEXT ASSEMBLY	REV	ECO	ISSUE DATE AND DESCRIPTION	DRFT	CHKD
		T	62689	JUL 10, 2015 ADD 5X05 OPTION AND REVISE NOTES	JNC	SN
		S	60056	MAR 06, 2015 REVISE ORDERING NUMBER	JNC	RS
		R	56068	JUL 25, 2014 REVISED AND REDRAWN	JNC	RS
		CHKD	CASTIGLIONE	DATE JUL 25, 2014	APPR R. SCHERER	DATE SEP 05, 2014
DIVISION: Interconnect Solutions SCALE: 2/1 DO NOT DRAWING		DIVISION CODE: EMSD TOLERANCES EXCEPT AS NOTED INCHES: .0 ± .01 .000 ± .005 .0000 ±		TITLE: HEADER, 4-WALL, .100 X .100 LATCH/EJECTOR, STRAIGHT & RA CAGE NUMBER: D78-5100-0772-3 MODEL: 3000 SERIES		
THIRD ANGLE PROJECTION INTERPRET PER ASME Y14.5 - 2009		MILLIMETERS: 0 ± .0 ± .3 .000 ± .13		REV. 1 OF 4 DET. 1/15 YES/NO SHT 1 OF 4		

78-5100-0772-3
 DRAWING NUMBER
 REV. 1
 AM UTC-05:00
 7/12/2016 8:14

3M™ FOUR-WALL HEADER, 3000 SERIES
 .100" X .100" LATCH/EJECTOR, STRAIGHT AND RIGHT ANGLE

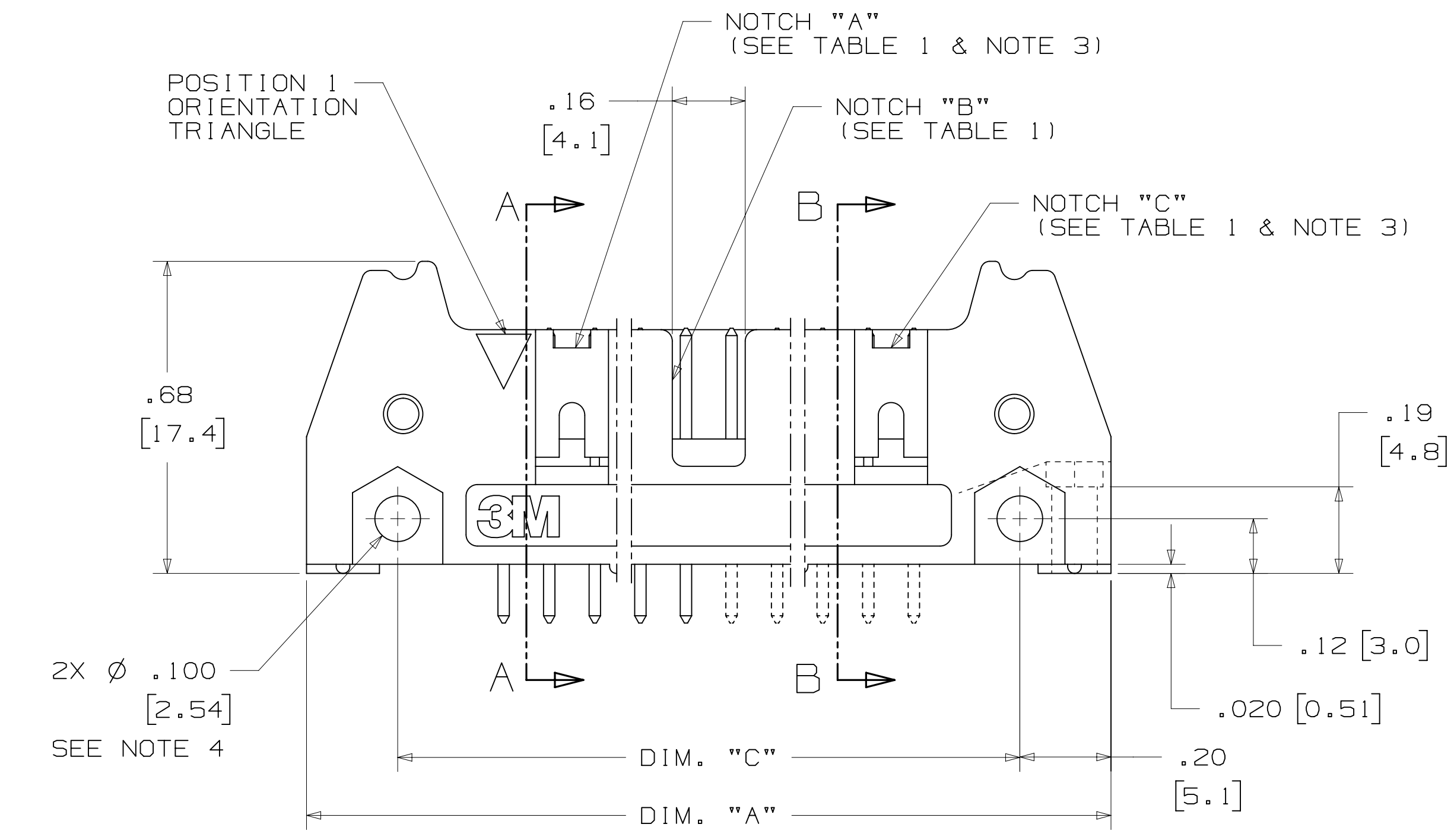
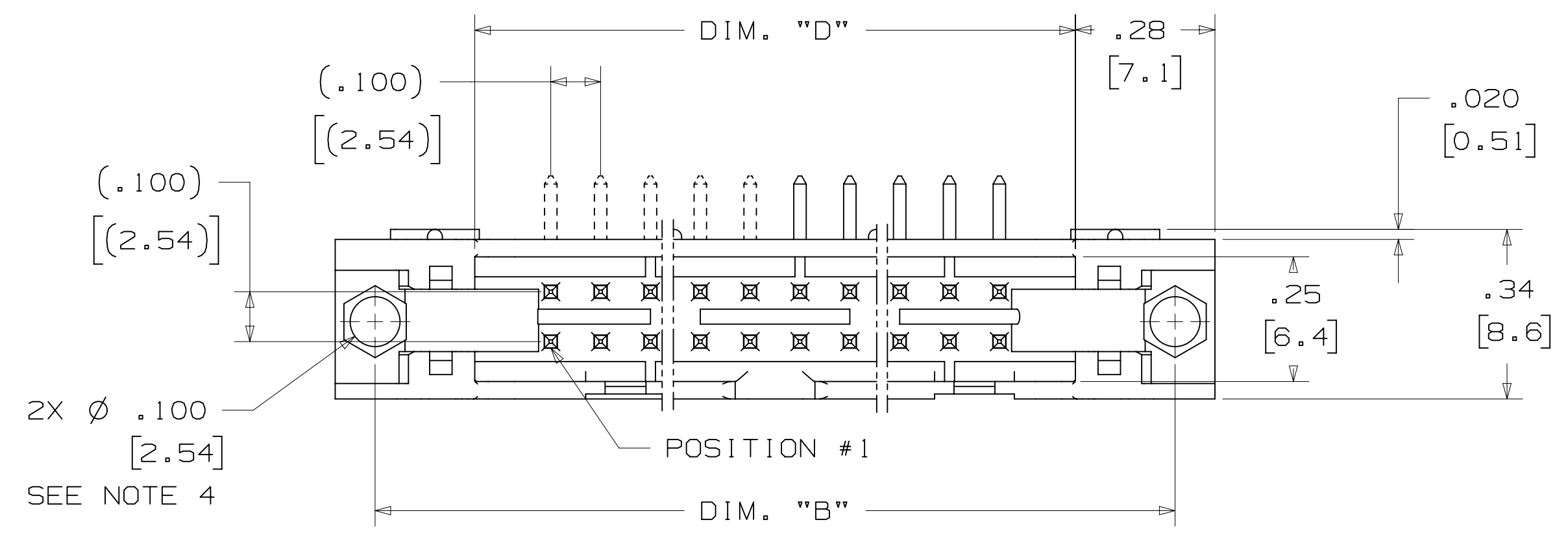
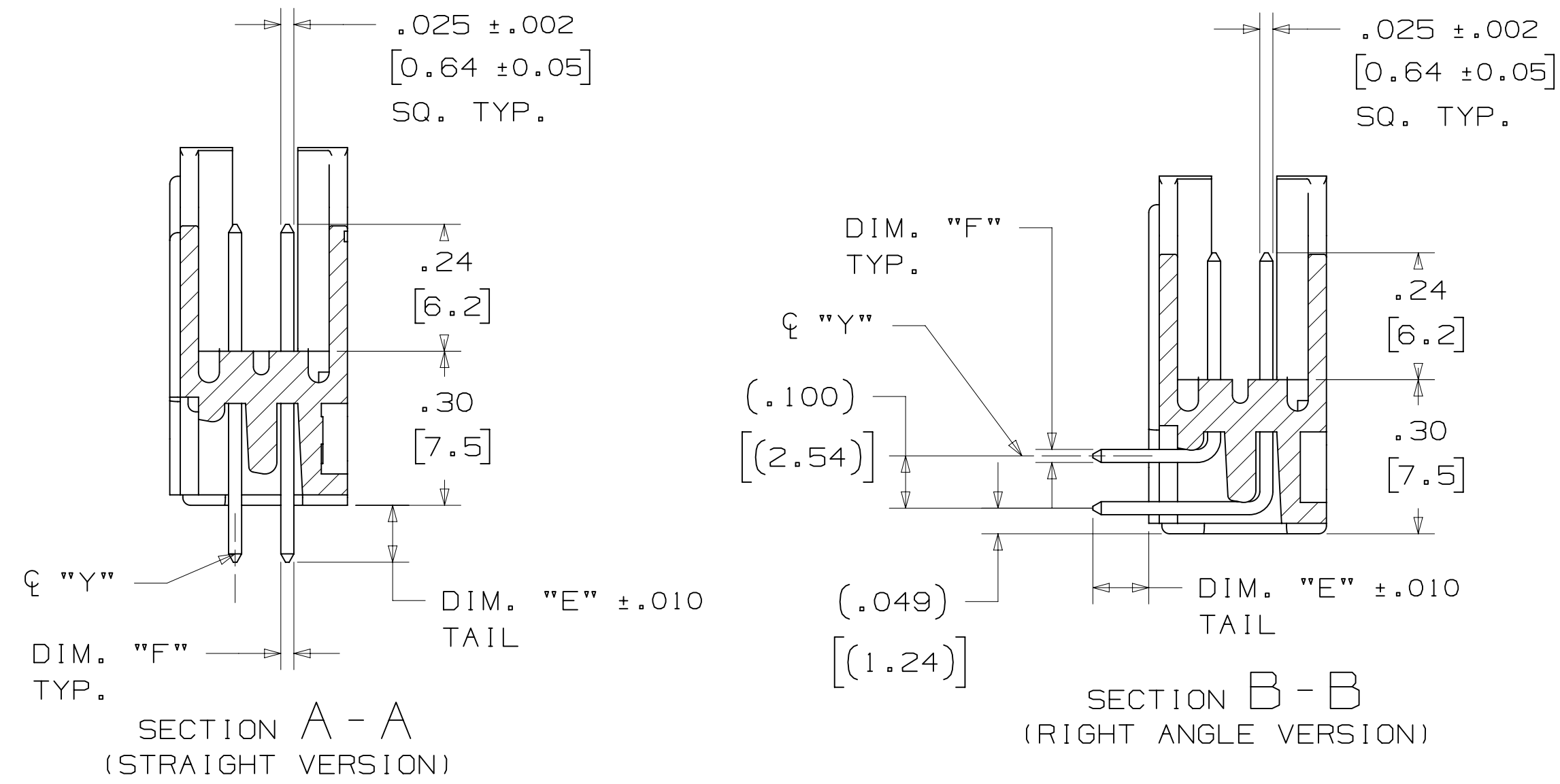

PIN QTY.	3M PART NUMBER	DIM. "A"	DIM. "B"	DIM. "C"	DIM. "D"	POLARIZING NOTCHES	PIN QTY.
06	3869	1.06 [27.0]	.905 [22.99]	.665 [16.89]	.51 [12.9]	B*	06
08	3889	1.16 [29.5]	1.005 [25.53]	.765 [19.43]	.61 [15.5]	B*	08
10	3793	1.26 [32.1]	1.105 [28.04]	.865 [21.97]	.71 [18.0]	BC	10
14	3314	1.46 [37.2]	1.305 [33.12]	1.065 [27.05]	.91 [23.1]	BC	14
16	3408	1.56 [39.7]	1.405 [35.66]	1.165 [29.59]	1.01 [25.6]	ABC	16
20	3428	1.76 [44.8]	1.604 [40.74]	1.365 [34.67]	1.21 [30.7]	ABC	20
24	3627	1.96 [49.9]	1.805 [45.82]	1.565 [39.75]	1.41 [35.8]	ABC	24
26	3429	2.06 [52.4]	1.905 [48.36]	1.665 [42.29]	1.51 [38.3]	ABC	26
30	3440	2.26 [57.5]	2.105 [53.44]	1.865 [47.37]	1.71 [43.4]	ABC	30
34	3431	2.46 [62.6]	2.305 [58.52]	2.065 [52.45]	1.91 [48.5]	ABC	34
40	3432	2.76 [70.2]	2.605 [66.14]	2.365 [60.07]	2.21 [56.1]	ABC	40
50	3433	3.26 [82.9]	3.105 [78.84]	2.865 [72.77]	2.71 [68.8]	ABC	50
60	3372	3.76 [95.6]	3.605 [91.54]	3.365 [85.47]	3.21 [81.5]	ABC	60
64	3764	3.96 [100.7]	3.805 [96.62]	3.565 [90.55]	3.41 [86.6]	ABC	64

* AVAILABLE WITHOUT CENTER NOTCH B. CONTACT 3M

3M PART NUMBER SUFFIX	CONTACT TAIL	DIM. "E"	PIN CROSS SECTION			DIM. "G"
			DIM. "F"	DIAGONALS	CORNER RADIUS	
-5XX2	.062 [1.57] THICK PC BOARD	.112 [2.84]	.0245+/- .0005 [.622]	.028+/- .001 [.71]	.0075 [.191] REF.	.035+/- .003 [.89] SEE NOTE 5
-6XX2						
-5X03	.094 [2.39] TO .125 [3.18] THICK PC BOARD	.155 [3.94]	.0245+/- .0005 [.622]	.028+/- .001 [.71]	.0075 [.191] REF.	.035+/- .003 [.89]
-6X03						
-5X05	WIRE WRAP TAIL FOR UP TO 3 LEVELS OF WIRE WRAP	.61 [15.5] REF.	.0250+/- .002 [.635]	.035+/- .003 [.89]	.003 [.08] MAX.	.045+/- .003 [1.14]

DESIGN REFERENCE	NEXT ASSEMBLY	REV	ECO	ISSUE DATE AND DESCRIPTION	DRFT	CHKD
		CASTIGLIONE		JUL 25, 2014		
DIVISION	DIVISION CODE	DATE	DATE	DATE	DATE	DATE
Interconnect Solutions	EMSD					
DO NOT SCALE DRAWING	SCALE 4/1	TOLERANCES EXCEPT AS NOTED	© 3M COPYR[IGHT] 2016 This document and the information it contains are 3M property and may not be reproduced or further distributed without 3M permission, or used or disclosed other than for 3M authorized purposes. All rights reserved.			
THIRD ANGLE PROJECTION	INTERPRET PER ASME Y14.5 - 2009	INCHES .00 ± .01 .000 ± .005 .0000 ±	TITLE HEADER, 4-WALL, .100 X .100 LATCH/EJECTOR, STRAIGHT & RA			
MAX SURFACE ROUGHNESS	MARKED ONLY	MILLIMETERS 0 ± .00 ± .13 .000 ±	CAGE NUMBER D78-5100-0772-3 T			
		ANGLES	MODEL 3000 SERIES			

78-5100-0772-3
 REV. 1
 DATE 05/2014
 AM UTC-05:00
 7/12/2016 8:14

3M™ FOUR-WALL HEADER, 3000 SERIES

.100" X .100" LATCH/EJECTOR, STRAIGHT AND RIGHT ANGLE

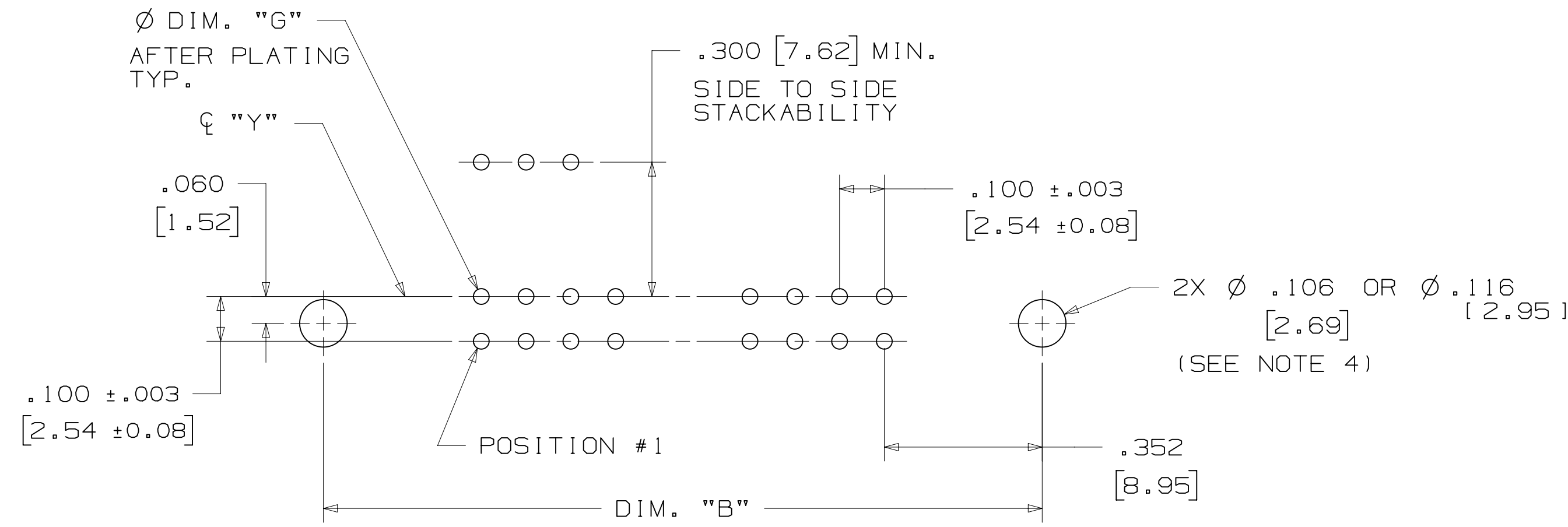

RECOMMENDED MOUNTING HOLE PATTERN
(STRAIGHT VERSION)

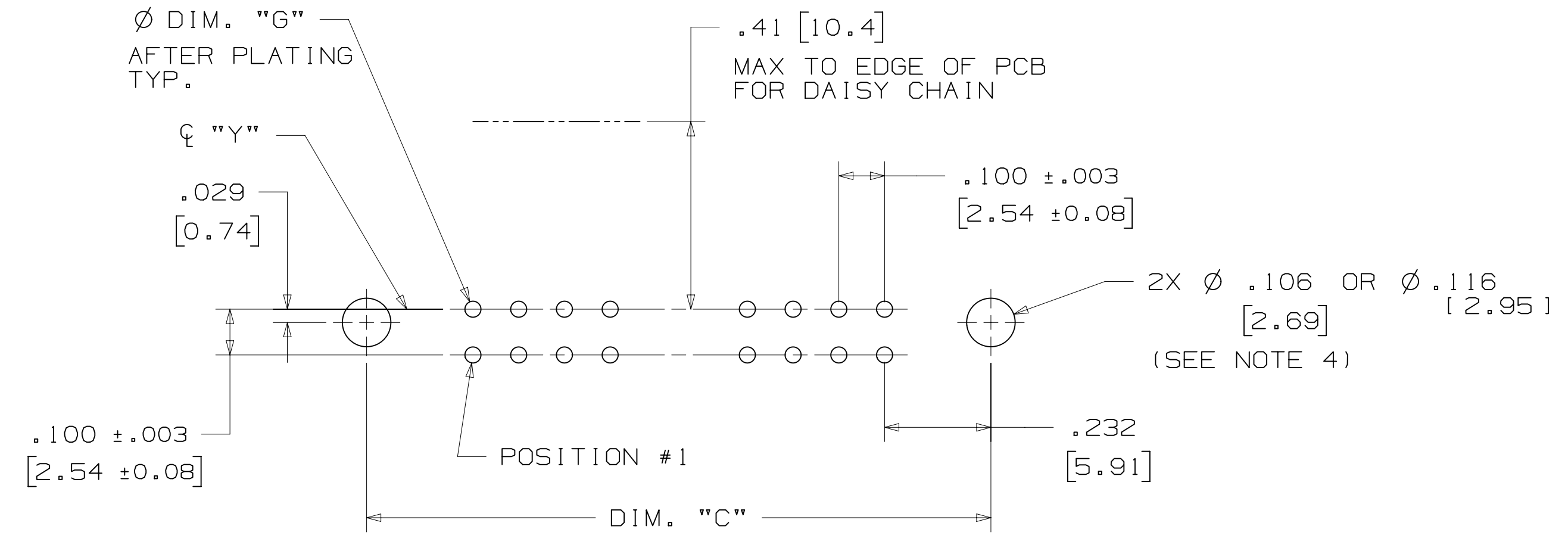

RECOMMENDED MOUNTING HOLE PATTERN
(RIGHT ANGLE VERSION)

PART CUSTOMIZATION

THIS SPEC SHEET DETAILS OUR STANDARD OFFERING.

3M HAS SEVERAL CAPABILITIES THAT CAN PROVIDE A PART TAILORED TO YOUR SPECIFIC NEEDS. ASK YOUR 3M SALES REPRESENTATIVE OR CUSTOMER SERVICE FOR MORE DETAILS.

BOTH SNAP-IN AND ROLL PIN LATCHES MAY BE ORDERED SEPARATELY. SNAP-IN AND ROLL PIN STYLE LATCHES ARE DIMENSIONALLY AND FUNCTIONALLY EQUIVALENT. IF ORDERING SNAP-IN OR ROLL PIN STYLE LATCHES SEPARATELY, PLEASE USE THE BELOW CHART.

MATERIAL	SHORT LATCH	LONG LATCH	LATCH STYLE	COLOR
HIGH TEMP. (PCT)	N3505-2B	N3505-3B	ROLL PIN	BLACK
HIGH TEMP (PPA)	N3505-30B	N3505-31B	SNAP-IN	BLACK

- * SELECTIVE PIN REMOVAL (ATA OR OTHER COMPATIBILITY)
- * WIRE WRAP TAILS STYLE

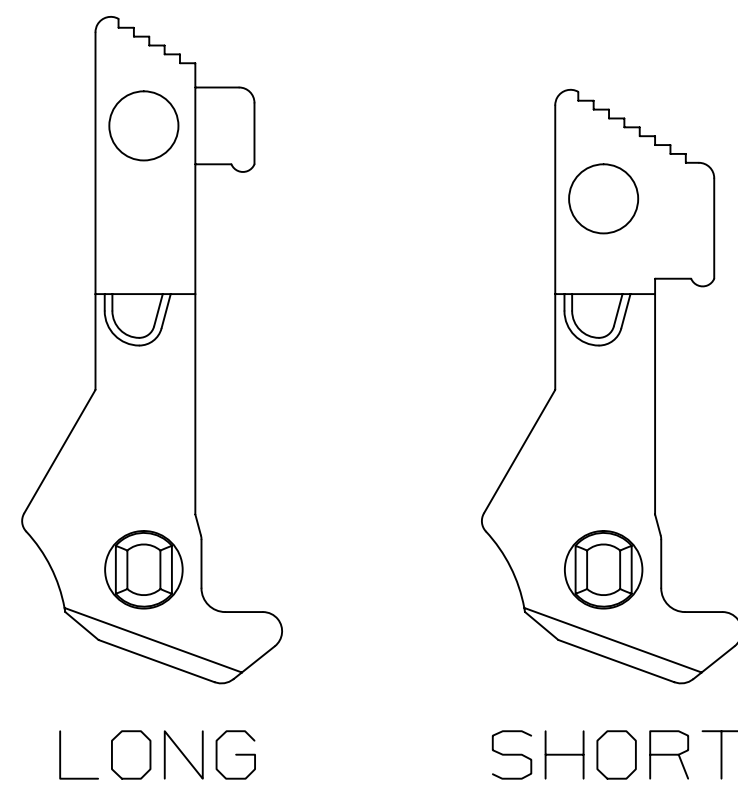

LONG SHORT

SNAP-IN LATCHES

NOTE:
SNAP-IN LATCHES CAN ONLY BE ORDERED SEPARATELY AND ARE THE CUSTOMERS RESPONSIBILITY TO INSTALL.

POLARIZING POST

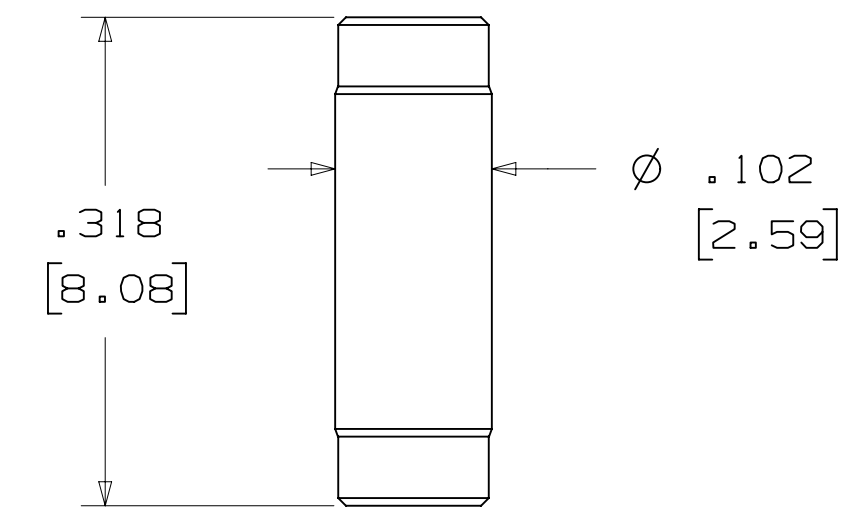

3M PART NO.	MATERIAL	COLOR
3201-4	LCP	BLACK

NOTE:
INSERT POST INTO ONE MOUNTING HARDWARE HOLE ON BOTTOM OF HEADER. SET POST TO PROTRUDE .115 [2.92]

K2 OPTION

2500 & 3000 SERIES SHROUDED HEADER						
TOTAL NO. OF PINS	NO. OF TAILS KINKED	POSITIONS KINKED				
10	4	3	4	7	8	
14	4	3	4	11	12	
16	4	3	4	13	14	
20	4	3	4	17	18	
24	4	3	4	21	22	
26	4	3	4	23	24	
30	4	5	6	25	26	
34	4	7	8	27	28	
36	4	7	8	27	28	
40	4	7	8	33	34	
50	4	7	8	43	44	
60	4	11	12	49	50	
64	4	11	12	53	54	

KINKED TAIL DETAIL:
- KINK IS LOCATED .05" BELOW BOTTOM SURFACE OF PLASTIC.
- EXTERNAL RADIUS OF KINK TOWARD PART CENTERLINE.

POLARIZING KEYS

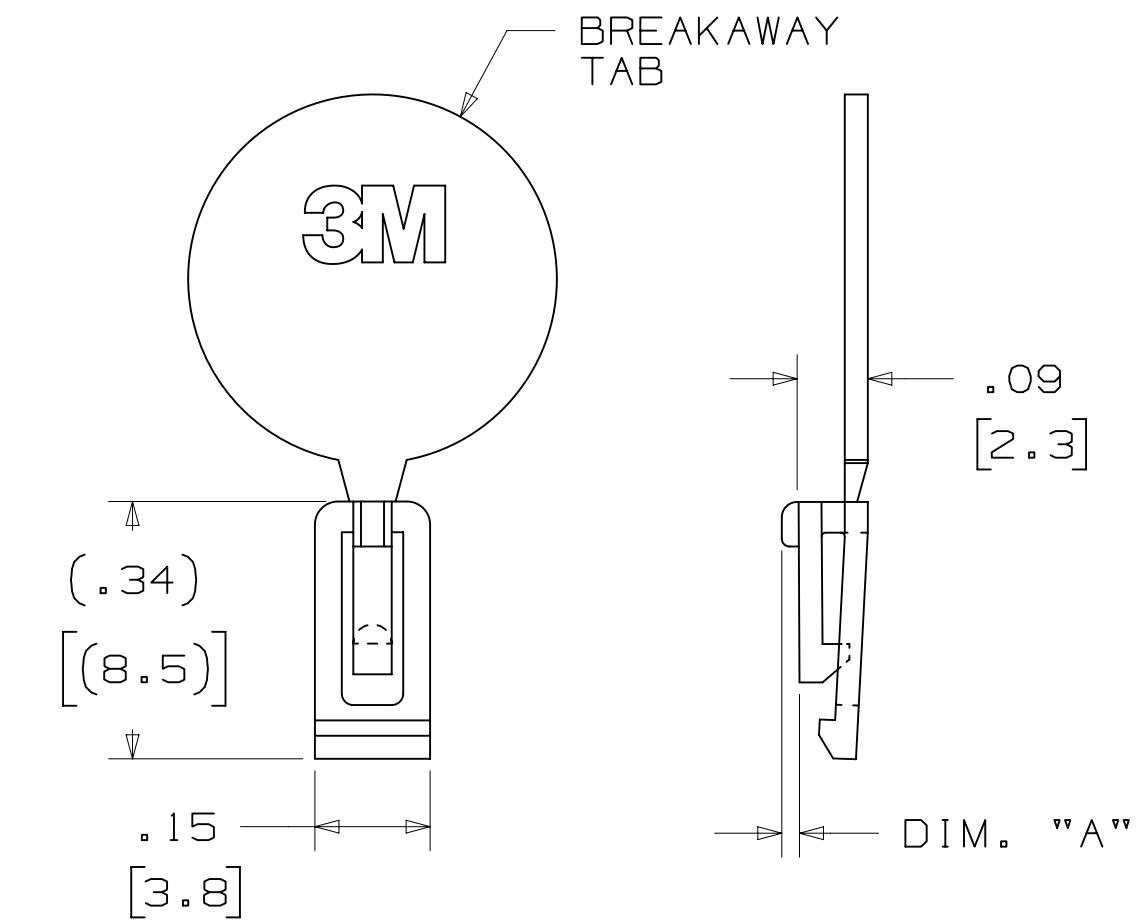

3M PART NO.	MATERIAL	COLOR	DIM. "A"
N3518	LCP	BLACK	.02

NOTE:
#2216 B/A SCOTCHWELD CAN BE USED TO ADHERE KEYS.

DESIGN REFERENCE	NEXT ASSEMBLY	REV	ECO	ISSUE DATE AND DESCRIPTION	DRFT	CHKD
		T	62689	JUL 10, 2015 ADD 5X05 OPTION AND REVISE NOTES	JNC	SN
		S	60056	MAR 06, 2015 REVISE ORDERING NUMBER	JNC	RS
		R	56068	JUL 25, 2014 REVISED AND REDRAWN	JNC	RS
				DATE: JUL 25, 2014		
				DATE: SEP 05, 2014		

DIVISION	DIVISION CODE	DATE	DATE
Interconnect Solutions	EMSD	COSTIGLIONE	R. SCHERER

DO NOT SCALE DRAWING	SCALE	TOLERANCES EXCEPT AS NOTED
	4 1	

INTERPRET PER ASME Y14.5 - 2009	TOLERANCES EXCEPT AS NOTED	MILLIMETERS

CAGE NUMBER	SIZE	DRAWING NO.	REV.
D	78-5100-0772-3	T	

REVISION
 DRAWING NUMBER
 78-5100-0772-3
 AM UTC-05:00
 7/12/2016 8:14

3M™ FOUR-WALL HEADER, 3000 SERIES
 .100" X .100" LATCH/EJECTOR, STRAIGHT AND RIGHT ANGLE

MOUNTING HARDWARE

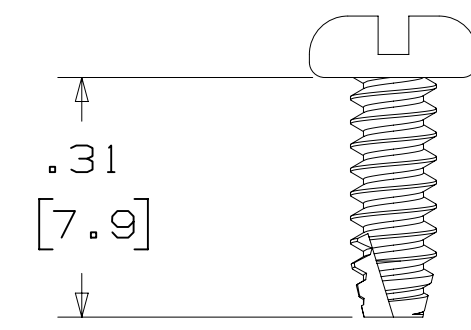

3341-5
 (INSTALL FROM BOTTOM OF BOARD)
 PANHEAD THREAD CUTTING SCREW:
 #4-24 X 5/16"
 TYPE: USA STD BT, FEDERAL BG
 MATERIAL: STAINLESS STEEL

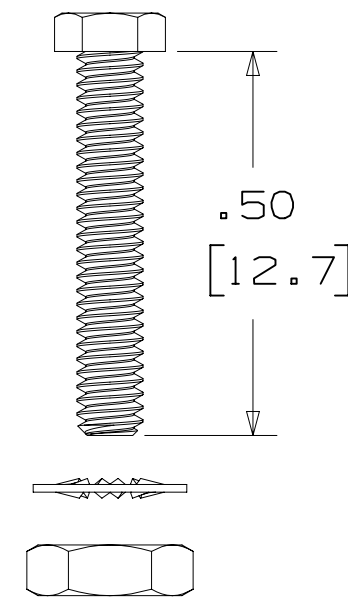

3341-6
 HEX HEAD BOLT, NUT AND WASHER:
 BOLT - #2-56 X 1/2"
 MATERIAL: STAINLESS STEEL

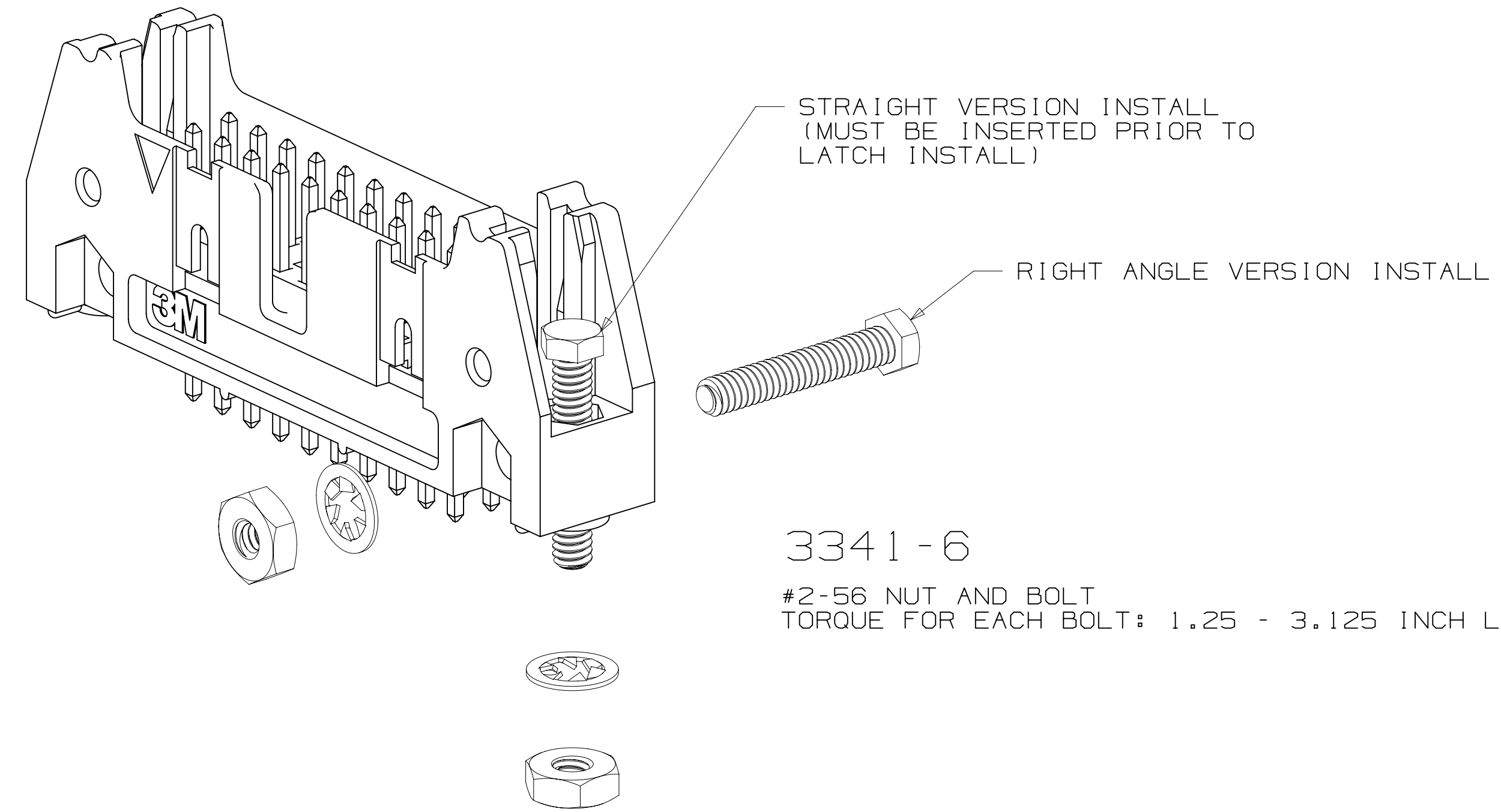

3341-6
 #2-56 NUT AND BOLT
 TORQUE FOR EACH BOLT: 1.25 - 3.125 INCH LBS.

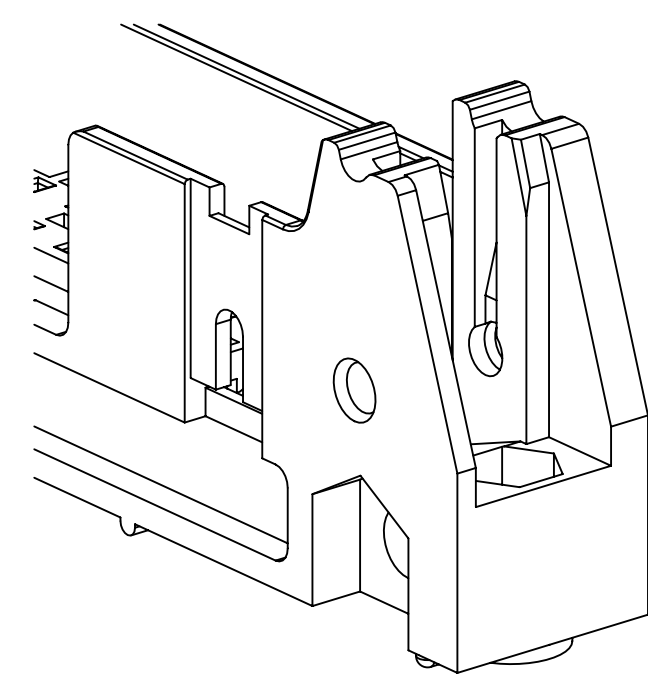

#4-24 TYPE BT SELF THREADING SCREW
 WHEN USING LATCHES, MAXIMUM LENGTH
 OF SCREW IS .250 INCHES PLUS
 THICKNESS OF THE BOARD.
 TORQUE FOR EACH SCREW IS 3-5 INCH LBS.

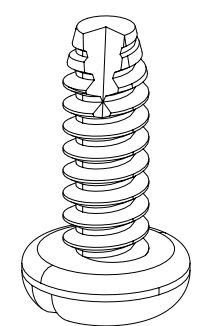

3341-5

DESIGN REFERENCE	NEXT ASSEMBLY	REV	ECO	ISSUE DATE AND DESCRIPTION	DRFT	CHKD
		T	62689	JUL 10, 2015 ADD 5X05 OPTION AND REVISE NOTES	JNC	SN
		S	60056	MAR 06, 2015 REVISE ORDERING NUMBER	JNC	RS
		R	56068	JUL 25, 2014 REVISED AND REDRAWN	JNC	RS
		CHKD	CASTIGLIONE	DATE JUL 25, 2014	DATE MFG	DATE SEP 05, 2014
		APPRV	R. SCHERER	DATE SEP 05, 2014		
DIVISION Interconnect Solutions		DIVISION CODE EMSD		© 3M COPYRIGHT 2016 This document and the information it contains are 3M property and may not be reproduced or further distributed without 3M permission, or used or disclosed other than for 3M authorized purposes. All rights reserved.		
DO NOT SCALE DRAWING	SCALE 4 1	TOLERANCES EXCEPT AS NOTED		TITLE HEADER, 4-WALL, .100 X .100 LATCH/EJECTOR, STRAIGHT & RA		
THIRD ANGLE PROJECTION		INCHES .00 ± .01 .000 ± .005 .0000 ±		CAGE NUMBER D78-5100-0772-3 T		
INTERPRET PER ASME Y14.5 - 2009		MILLIMETERS 0 ± .0 ± .3 .00 ± .13 .000 ±		MODEL 3000 SERIES		
MAX SURFACE ROUGHNESS		<input checked="" type="checkbox"/> UNMARKED SURFACES <input type="checkbox"/> MARKED ONLY		DET. <input type="checkbox"/> YES <input checked="" type="checkbox"/> NO SHT 4 OF 4		

78-5100-0772-3
 DRAWING NUMBER
 T
 REVISION
 AM UTC-05:00
 7/12/2016 8:14
 Image: T.2



Компания «ЭлектроПласт» предлагает заключение долгосрочных отношений при поставках импортных электронных компонентов на взаимовыгодных условиях!

Наши преимущества:

- Оперативные поставки широкого спектра электронных компонентов отечественного и импортного производства напрямую от производителей и с крупнейших мировых складов;
- Поставка более 17-ти миллионов наименований электронных компонентов;
- Поставка сложных, дефицитных, либо снятых с производства позиций;
- Оперативные сроки поставки под заказ (от 5 рабочих дней);
- Экспресс доставка в любую точку России;
- Техническая поддержка проекта, помощь в подборе аналогов, поставка прототипов;
- Система менеджмента качества сертифицирована по Международному стандарту ISO 9001;
- Лицензия ФСБ на осуществление работ с использованием сведений, составляющих государственную тайну;
- Поставка специализированных компонентов (Xilinx, Altera, Analog Devices, Intersil, Interpoint, Microsemi, Aeroflex, Peregrine, Syfer, Eurofarad, Texas Instrument, Miteq, Cobham, E2V, MA-COM, Hittite, Mini-Circuits, General Dynamics и др.);

Помимо этого, одним из направлений компании «ЭлектроПласт» является направление «Источники питания». Мы предлагаем Вам помощь Конструкторского отдела:

- Подбор оптимального решения, техническое обоснование при выборе компонента;
- Подбор аналогов;
- Консультации по применению компонента;
- Поставка образцов и прототипов;
- Техническая поддержка проекта;
- Защита от снятия компонента с производства.



Как с нами связаться

Телефон: 8 (812) 309 58 32 (многоканальный)

Факс: 8 (812) 320-02-42

Электронная почта: org@eplast1.ru

Адрес: 198099, г. Санкт-Петербург, ул. Калинина, дом 2, корпус 4, литера А.