

REVISIONS					
REV	ECO	DESCRIPTION	DATE	BY	APPR
A1	-	RELEASE NUMBER	30/NOV/18	ROOKIE	TOMMY

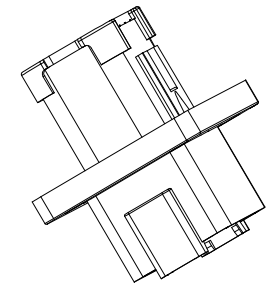
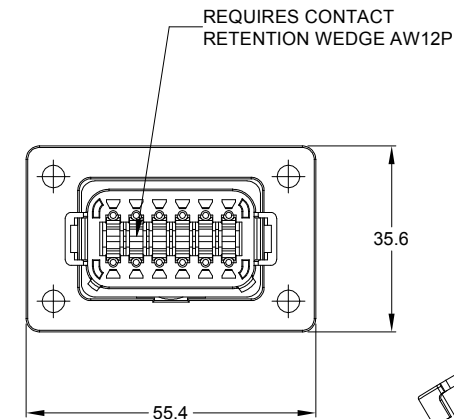
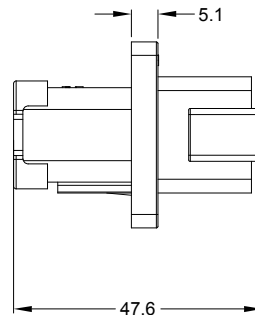
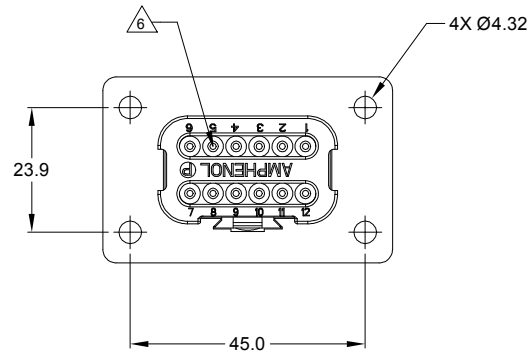
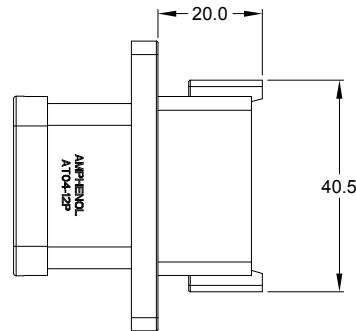

NOTES: UNLESS OTHERWISE SPECIFIED

1. SEE SHEET 2 FOR KEY ARRANGEMENTS AND COLORS.

2. MATERIAL:
HOUSING: THERMOPLASTIC
SEAL: SILICONE RUBBER

3. MODIFICATIONS: FLANGE, END CAP

4. SPECIFICATIONS:
4.1 CURRENT RATING: 13 AMPS
4.2 OPERATING TEMPERATURE: -55°C TO +125°C.
4.3 DIELECTRIC WITHSTANDING VOLTAGE: LESS THAN 2 MILLIAMPS CURRENT LEAKAGE @ 1500 VOLTS AC.
4.4 INSULATION RESISTANCE: 1000 MEGOHMS MIN @ 25°C.
4.5 MOISTURE RESISTANCE: IP67 (MATED CONDITION)
4.6 MATING CYCLE DURABILITY: 100 CYCLES
4.7 RoHS COMPLIANT

5. MATING PART: AT06-12SX* PLUG.
(X=A,B,C,D KEYS, * = MODIFICATIONS AND COLORS)

6. ALL DIMENSIONS ARE FOR REFERENCE USE ONLY.

7. CONTACT SIZE AND REAR SEAL WIRE RANGE:

CONTACT SIZE	MIN. INSUL O.D.	MAX. INSUL O.D.	TYPICAL WIRE RANGE
16	2.24 mm (.088 in)	3.68 mm (.145 in)	14 - 20 AWG

QUANTITY	SEE SHEET 2 PART NUMBER	DESCRIPTION	ITEM
		12P RECEPTACLE, FLANGE MOUNT, END CAP	
MATERIALS LIST			
UNLESS OTHERWISE SPECIFIED: 1) All dimensions are in metric(mm). 2) Tolerances are as follows: 1 PL DEC ±0.30 2 PL DEC ±0.15 3 PL DEC ±0.08 Fractions ±1/64 Angles ±1° 3) Note reference =		SIGNATURES DATE DRAWN: ROOKIE 30/NOV/18 CHECKED: ORION 30/NOV/18 ENGINEER: APPROVAL: TOMMY 30/NOV/18 CUSTOMER:	
MATERIAL SPECIFICATIONS: PROCESS SPECIFICATIONS: THIS DRAWING IS SUPPLIED FOR INFORMATION ONLY. DESIGN FEATURES, SPECIFICATIONS AND PERFORMANCE DATA SHOWN HEREON ARE THE PROPERTY OF THE AMPHENOL CORPORATION. NO RIGHTS OF REPRODUCTION ARE IMPLIED. ALL DIMENSIONS ARE SUBJECT TO NORMAL MANUFACTURING VARIATIONS.		Amphenol Sine Systems - www.amphenol-sine.com 44724 Morley Drive Clinton Township, MI 48036 12P RECEPTACLE, FLANGE MOUNT, END CAP	
SIZE TYPE DWG NO. REVISION B C- AT04-12PX-LE07 A1		SCALE: NONE SHEET 1 OF 3	

TITLE: 12P RECEPTACLE, FLANGE MOUNT, END CAP
DWG NO.: AT04-12PX-LE07
REV: A1
SH: 1
OF: 3

REVISIONS					
REV	ECO	DESCRIPTION	DATE	BY	APPR
A1	-	RELEASE NUMBER	30/NOV/18	ROOKIE	TOMMY

KEY A CONFIGURATION
STANDARD COLOR:GREY

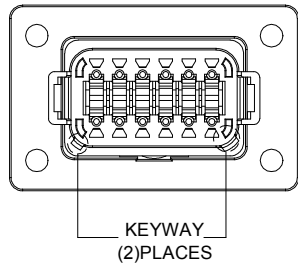
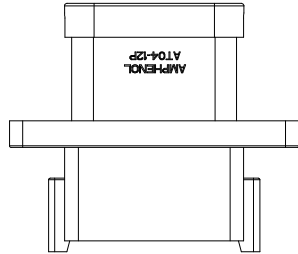

KEY-A CONFIGURATION	
COLOR	PART NUMBER
GREY	AT04-12PA-LE07

KEY B CONFIGURATION
STANDARD COLOR:BLACK

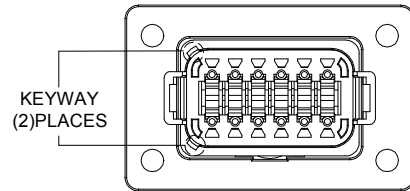
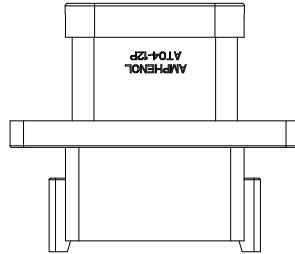

KEY-B CONFIGURATION	
COLOR	PART NUMBER
BLACK	AT04-12PB-LE07

KEY C CONFIGURATION
STANDARD COLOR:GREEN

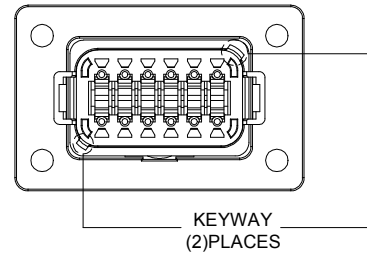
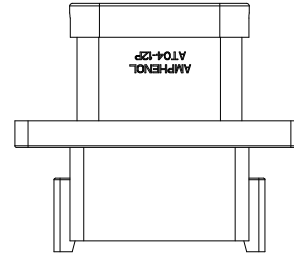

KEY-C CONFIGURATION	
COLOR	PART NUMBER
GREEN	AT04-12PC-LE07

KEY D CONFIGURATION
STANDARD COLOR:BROWN

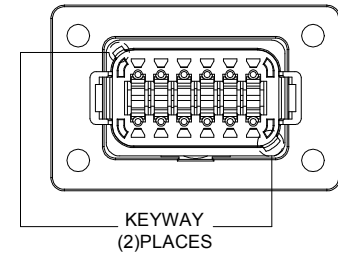
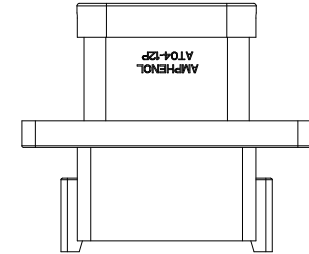

KEY-D CONFIGURATION	
COLOR	PART NUMBER
BROWN	AT04-12PD-LE07

SEE SHEET 2		DESCRIPTION		ITEM		
PART NUMBER						
QUANTITY	MATERIALS LIST					
UNLESS OTHERWISE SPECIFIED 1) All dimensions are in metric(mm). 2) Tolerances are as follows: 1 PL DEC ±0.30 Fractions ±1/64 2 PL DEC ±0.15 Angles ±1° 3 PL DEC ±0.06 3) Note reference =	SIGNATURES	DATE	 Sine Systems - www.amphenol-sine.com 44724 Morley Drive Clinton Township, MI 48036 12P RECEPTACLE, FLANGE MOUNT, END CAP			
	DRAWN: ROOKIE	30/NOV/18				
CHECKED: ORION	30/NOV/18					
APPROVAL: TOMMY	30/NOV/18					
MATERIAL SPECIFICATIONS:	CUSTOMER:					
PROCESS SPECIFICATIONS:	THIS DRAWING IS SUPPLIED FOR INFORMATION ONLY. DESIGN FEATURES, SPECIFICATIONS AND PERFORMANCE DATA SHOWN HEREON ARE THE PROPERTY OF THE AMPHENOL CORPORATION. NO RIGHTS OF REPRODUCTION ARE IMPLIED. ALL DIMENSIONS ARE SUBJECT TO NORMAL MANUFACTURING VARIATIONS.		SIZE	TYPE	DWG NO.	REVISION
NEXT ASSY:	SCALE: NONE		B	C-	AT04-12PX-LE07	A1
			SHEET 2 OF 3			

TITLE: 12P RECEPTACLE, FLANGE MOUNT, END CAP
 DWG NO.: AT04-12PX-LE07
 REV: A1
 SH: 2
 OF: 3

REVISIONS					
REV	ECO	DESCRIPTION	DATE	BY	APPR
A1	-	RELEASE NUMBER	30/NOV/18	ROOKIE	TOMMY

FOR REFERENCE ONLY

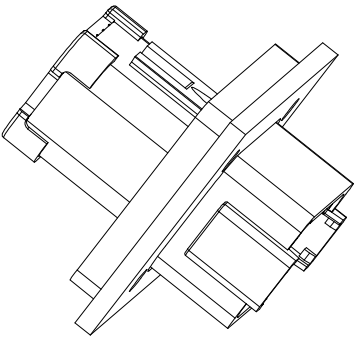

FRONT MOUNT

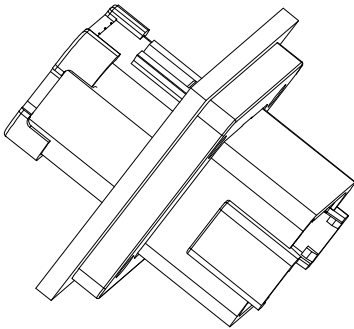

REAR MOUNT

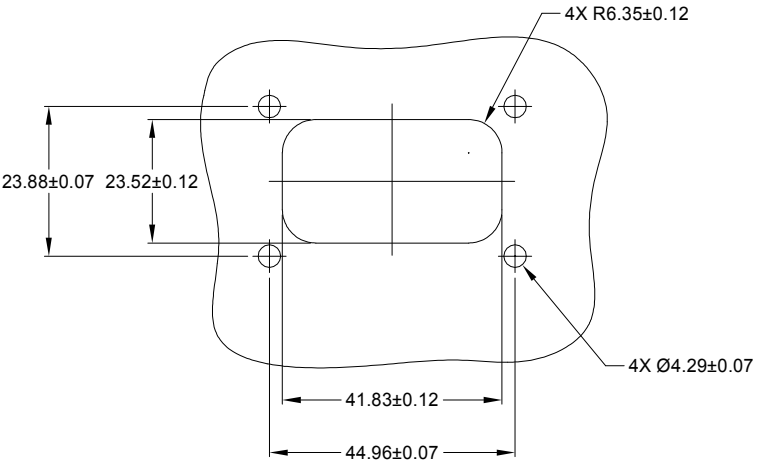

RECOMMENDED CUTOUT
FRONT AND REAR MOUNT

SEE SHEET 2	
PART NUMBER	DESCRIPTION
ITEM	

QUANTITY	MATERIALS LIST			ITEM
UNLESS OTHERWISE SPECIFIED 1) All dimensions are in metric(mm). 2) Tolerances are as follows: 1 PL DEC ±0.30 Fractions ±1/64 2 PL DEC ±0.15 Angles ±1° 3 PL DEC ±0.08 3) Note reference =	SIGNATURES	DATE	<div style="text-align: center;"> <h1>Amphenol</h1> <p>Sine Systems - www.amphenol-sine.com 44724 Morley Drive Clinton Township, MI 48036</p> <p>12P RECEPTACLE, FLANGE MOUNT, END CAP</p> </div>	
	DRAWN: ROOKIE	30/NOV/18		
	CHECKED: ORION	30/NOV/18		
	APPROVAL: TOMMY	30/NOV/18		
MATERIAL SPECIFICATIONS:	THIS DRAWING IS SUPPLIED FOR INFORMATION ONLY. DESIGN FEATURES, SPECIFICATIONS AND PERFORMANCE DATA SHOWN HEREON ARE THE PROPERTY OF THE AMPHENOL CORPORATION. NO RIGHTS OF REPRODUCTION ARE IMPLIED. ALL DIMENSIONS ARE SUBJECT TO NORMAL MANUFACTURING VARIATIONS.			SCALE: NONE
PROCESS SPECIFICATIONS:	SIZE: B C-	TYPE: NONE	DWG NO: AT04-12PX-LE07	REVISION: A1
NEXT ASSY:	SHEET 3 OF 3			

TITLE: 12P RECEPTACLE, FLANGE MOUNT, END CAP
 DWG NO: AT04-12PX-LE07
 REV: A1
 SH: 3
 OF: 3



Компания «ЭлектроПласт» предлагает заключение долгосрочных отношений при поставках импортных электронных компонентов на взаимовыгодных условиях!

Наши преимущества:

- Оперативные поставки широкого спектра электронных компонентов отечественного и импортного производства напрямую от производителей и с крупнейших мировых складов;
- Поставка более 17-ти миллионов наименований электронных компонентов;
- Поставка сложных, дефицитных, либо снятых с производства позиций;
- Оперативные сроки поставки под заказ (от 5 рабочих дней);
- Экспресс доставка в любую точку России;
- Техническая поддержка проекта, помощь в подборе аналогов, поставка прототипов;
- Система менеджмента качества сертифицирована по Международному стандарту ISO 9001;
- Лицензия ФСБ на осуществление работ с использованием сведений, составляющих государственную тайну;
- Поставка специализированных компонентов (Xilinx, Altera, Analog Devices, Intersil, Interpoint, Microsemi, Aeroflex, Peregrine, Syfer, Eurofarad, Texas Instrument, Miteq, Cobham, E2V, MA-COM, Hittite, Mini-Circuits, General Dynamics и др.);

Помимо этого, одним из направлений компании «ЭлектроПласт» является направление «Источники питания». Мы предлагаем Вам помощь Конструкторского отдела:

- Подбор оптимального решения, техническое обоснование при выборе компонента;
- Подбор аналогов;
- Консультации по применению компонента;
- Поставка образцов и прототипов;
- Техническая поддержка проекта;
- Защита от снятия компонента с производства.



Как с нами связаться

Телефон: 8 (812) 309 58 32 (многоканальный)

Факс: 8 (812) 320-02-42

Электронная почта: org@eplast1.ru

Адрес: 198099, г. Санкт-Петербург, ул. Калинина, дом 2, корпус 4, литера А.