

GMT HAND TOOL RATCHET ADJUSTMENT (WHERE APPLICABLE)

DMC DANIELS
MANUFACTURING
CORPORATION
DATASHEET

THIS HAND TOOL MUST NOT BE USED IN ANY POWERED "PRESS" AS DEFINED BY OSHA CFR 1910.211 (46)

SEE PAGE 3 FOR IMPORTANT INFORMATION CONCERNING LIMITED WARRANTY, AND LIMITATION OF LIABILITY.

Construct a Calibration Fixture and position tool assembly as shown in Figure 1. Compress handles and gage by turning the drive screw clockwise. Note the compression force required for the pawl to release from the last tooth of the ratchet. To adjust ratchet, tool must be in open position. Using a 1/2 inch wrench, loosen the screw cap about 1/2 a turn. Next, turn the eccentric screw clockwise to increase the compression force (causing a tighter crimp) and counter clockwise to decrease the compression force. While holding eccentric screw in desired position, tighten screw cap about 1/8 turn after snug. **CAUTION: DO NOT OVER TIGHTEN SCREW CAP – TOOL WILL JAM.** Repeat this procedure until desired force of 40 ± 5 lb. is achieved.

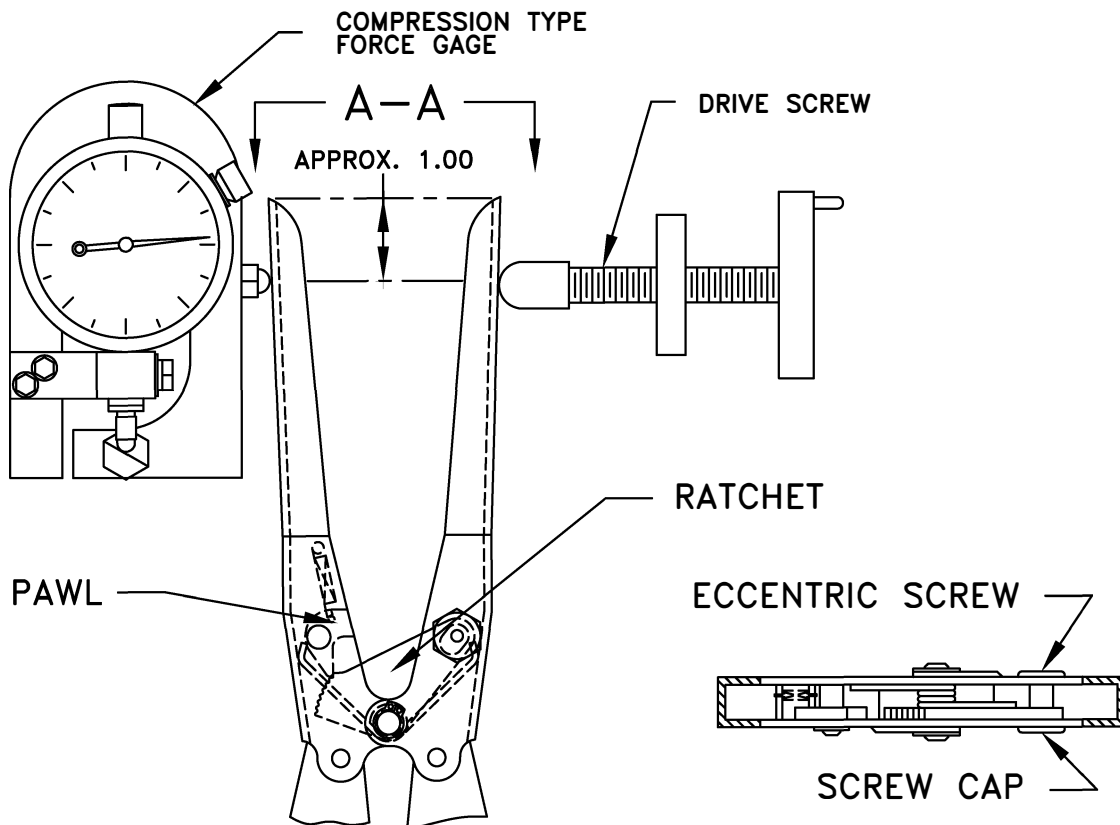

FIGURE 1

VIEW A-A
FIGURE 2

DAILY MAINTENANCE

A properly crimped terminal is controlled by the following maintenance and inspection procedures.

- A. Clean all dust, dirt, moisture and other foreign matter from the crimp jaws that could damage the crimp area of the dies.
- B. The pivot pin and ratched pawl bearing surface should be lubricated to ensure a smooth operation.
- C. When storing the tool, close the handles until the ratchet pawl is about to be released from the last tooth of the ratchet. This will help prevent the dies from being damaged.

PERIODIC INSPECTION PROCEDURE

Visual inspections should be performed on the tool based on the amount of use, working conditions and operator skill and care.

- A. Clean tool die area with solvent or brush.
- B. Check crimp area of dies for damage.
- C. If tool jams or locks, check the ratchet for dirt and lubrication.

CARE OF TOOL

It is a good practice to keep indenter tips free of residual color band deposits and other debris. A small wire brush may be used for this purpose.

We strongly recommend that you:

1. DO NOT immerse tools in cleaning solution.
2. DO NOT spray oil into tool to lubricate except as noted in Section B under Daily Manintenance.
3. DO NOT attempt to disassemble tool or make repairs.

This is a precision hand crimping tool and should be handled as such.

DMC offers complete refurbishing and recalibration services.

DMC engineers and manufactures complete tool kits to satisfy individual customer requirements, such as total aircraft support, general shop maintenance or production, on board ship and vehicle service, etc.

LIMITATION OF LIABILITY

DANIELS MANUFACTURING CORPORATION IS NOT LIABLE FOR CONSEQUENTIAL OR SPECIAL DAMAGES OF ANY NATURE OR KIND RESULTING FROM THE USE, OR MISUSE, OF ANY OF ITS PRODUCTS. OWNERS AND USERS OF DMC PRODUCTS ASSUME FULL RESPONSIBILITY FOR INSTRUCTING THEIR EMPLOYEES IN THE PROPER AND SAFE USE OF SUCH PRODUCTS.

LIMITED WARRANTY

DMC (Daniels Manufacturing Corporation) warrants each new product sold by it to be free from defects in material and workmanship under normal use and service. DMC's obligation under this warranty is limited to the free correction or, at DMC's option, the refund of the purchase price of any such product which proves defective in normal service within ninety (90) days after delivery to the first user, provided that the product is returned to DMC with all transportation charges prepaid and which shall appear to DMC's satisfaction, after DMC's inspection, to have been defective in material or workmanship, it being understood that DMC products are not consumer products. This warranty shall not cover any damage to any product which, in the opinion of DMC, was caused by normal wear, misuse, improper operation, tampering, neglect or accident. This warranty is in lieu of all other warranties express or implied. No warranty, express or implied, is made or authorized to be made or assumed with respect to products of Daniels Manufacturing Corporation other than those herein set forth.



Компания «ЭлектроПласт» предлагает заключение долгосрочных отношений при поставках импортных электронных компонентов на взаимовыгодных условиях!

Наши преимущества:

- Оперативные поставки широкого спектра электронных компонентов отечественного и импортного производства напрямую от производителей и с крупнейших мировых складов;
- Поставка более 17-ти миллионов наименований электронных компонентов;
- Поставка сложных, дефицитных, либо снятых с производства позиций;
- Оперативные сроки поставки под заказ (от 5 рабочих дней);
- Экспресс доставка в любую точку России;
- Техническая поддержка проекта, помощь в подборе аналогов, поставка прототипов;
- Система менеджмента качества сертифицирована по Международному стандарту ISO 9001;
- Лицензия ФСБ на осуществление работ с использованием сведений, составляющих государственную тайну;
- Поставка специализированных компонентов (Xilinx, Altera, Analog Devices, Intersil, Interpoint, Microsemi, Aeroflex, Peregrine, Syfer, Eurofarad, Texas Instrument, Miteq, Cobham, E2V, MA-COM, Hittite, Mini-Circuits, General Dynamics и др.);

Помимо этого, одним из направлений компании «ЭлектроПласт» является направление «Источники питания». Мы предлагаем Вам помощь Конструкторского отдела:

- Подбор оптимального решения, техническое обоснование при выборе компонента;
- Подбор аналогов;
- Консультации по применению компонента;
- Поставка образцов и прототипов;
- Техническая поддержка проекта;
- Защита от снятия компонента с производства.



Как с нами связаться

Телефон: 8 (812) 309 58 32 (многоканальный)

Факс: 8 (812) 320-02-42

Электронная почта: org@eplast1.ru

Адрес: 198099, г. Санкт-Петербург, ул. Калинина, дом 2, корпус 4, литера А.