

SPECIFICATION

- Part No. : **FXR.07.52.0075X.A**
- Product Name : Circular Flexible Near-Field Communications
Antenna with 75mm Twisted Pair 28AWG Cable
and ACH(F) connector
- Features : 13.56 MHz Antenna
Flexible Low Profile Embedded Antenna
Diameter: 45.5 mm
Thickness: 0.24 mm
Peel and stick 3M adhesive on back
75mm Twisted Pair 28AWG Cable with Teflon
and ACH(F) Connector
RoHS Compliant



1. Introduction

The FXR.07.52.0075X.A is a circular, flexible, NFC (Near Field Communications) antenna for use in mobile devices and other applications such as keycards, payment systems, and boarding passes. The design provides a flexible NFC antenna with 75mm twisted pair 28AWG cable that can be adhered to the plastic enclosure of the device for ease of installation and work with specific 13.56MHz RFID and NFC chips which need to connect via JST ACH connector.

With NFC antennas being commonly attached to the battery of mobile devices, they can be customized with a ferrite flux director to provide isolation from the battery or other components within the device. Using the antenna on a conductive surface without a ferrite layer will result in extremely short range or complete failure to communicate. The coil inductance noted below can help estimate a capacitance value for creating resonance at 13.56MHz.

Typical applications

- Mobile devices
- Electronic wallets
- Health care ID scanners
- Payment readers
- Office ID
- Access control
- Internet Of Things

Customized antennas for specific applications, shape, and impedance match can also be provided for a NRE and are subject to MOQ. Contact your regional Taoglas sales

office for more information and support on our NFC antenna range.

2. Specifications

Flexible PCB Near-Field Communications Antenna		
Frequency	13.56	MHz
Inductance @ 13.56 MHz	6.4	µH
Mechanical		
Antenna Dimensions	Diameter: 45.5 mm Thickness: 0.24 mm	
Cable Length	75 mm	
Connector Type	ACH(F)	
Adhesive	3M 467	
Weight	2g	
Environmental		
Operation Temperature	-40°C to 85°C	
Storage Temperature	-40°C to 85°C	
Humidity	Non-condensing 65°C 95% RH	

3. Antenna Application

3.1. Test setup

A test fixture is used to measure the maximum interrogation distance. The FXR.07.52.0075.A antenna is connected to a NFC evaluation board and then placed on the fixed part of the fixture.

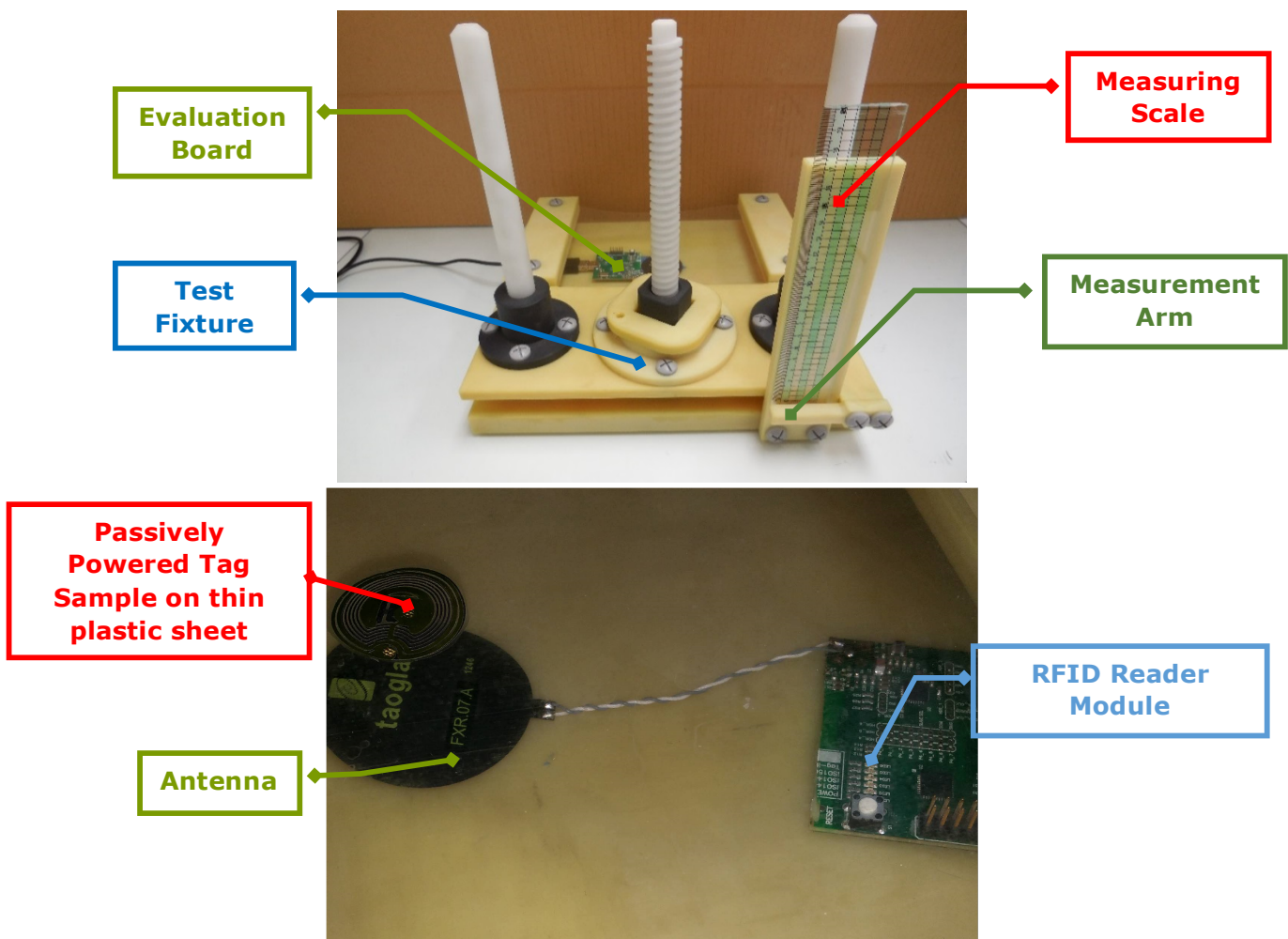

The test sample is placed on a thin sheet of plastic connected to the movable part of the fixture. Then the distance is carefully adjusted until the reader can no longer read the sample, thus the maximum interrogation distance is displayed in the ruler.

3.2. RFID tags used for test

A total of 8 RFID tags were used to measure the interrogation distances. The next picture shows type 1 and type 2 respectively.

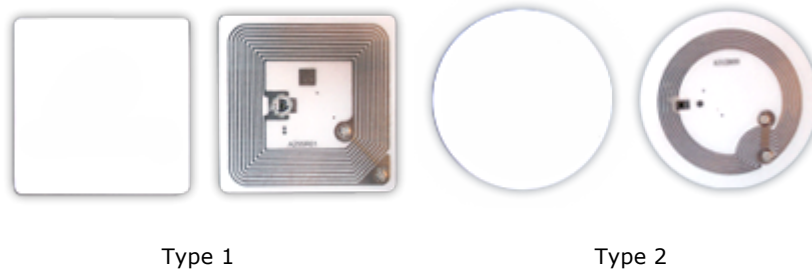

Type 1 tag is based on ISO/IEC 14443A standard and has 512 bytes of memory. Type 2 tag is based on ISO/IEC 14443A standard and has 192 bytes of memory.

The next picture shows the Tag-it HF-I RFID tags from Texas Instruments: RI-102-112, RI-I11-112, RI-I03-112, RI-I16-112, button type, and RI-I17-112.

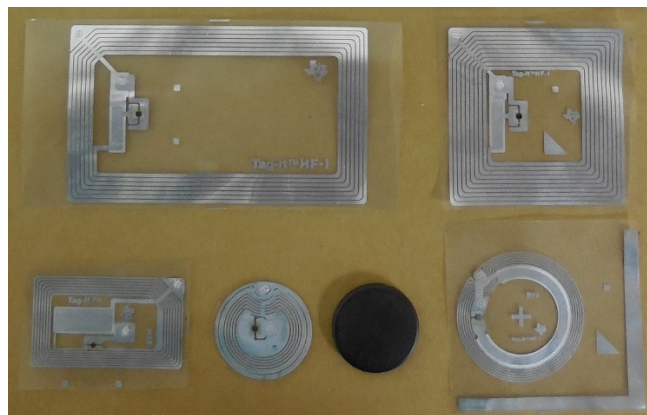

The Tag-it HF-I Plus Transponder Inlay family of Texas Instruments RFID is based on the ISO/IEC 15693 standard for contactless integrated circuit cards (vicinity cards) and ISO/IEC 18000-3 standard for item management.

3.3. Matching

The interrogation distances presented here were taken with the antenna connected directly to the evaluation boards with the default matching circuit. This is not necessarily the optimal matching circuit that could be designed for a particular antenna. We kept the default matching of each evaluation board to minimize the number of variables in testing and keep integration as simple as possible.

As with any matching network the exact circuit and values for an optimal network depend on the combination of antenna, NFC circuit, any intervening transmission line and the environment presented to the antenna. These factors are specific to the particular end product.

As a starting point, to achieve the read range results presented here, use the matching network detailed in the schematic of the evaluation board for your particular NFC chip and keep the antenna free of any obstruction. Once you can demonstrate successful reads you can then optimize performance as desired.

If the matching network is required, you should implement the following topology:

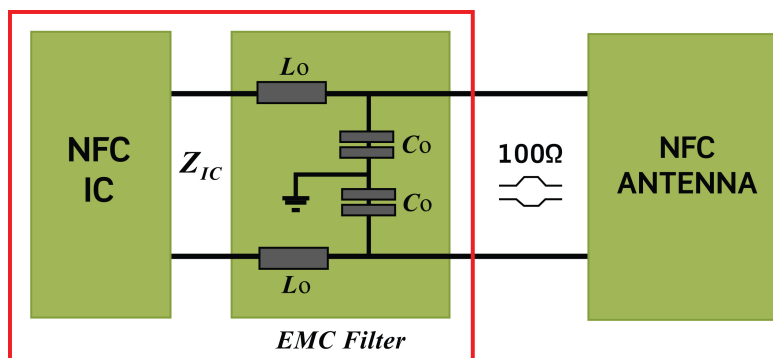

The matching circuit should be designed to match the IC impedance Z_{IC} to 100Ω and then connect the antenna through a 100Ω differential pair.

3.4. Test results

A total of 8 sample devices were used to measure the interrogation distances in two scenarios, over plastic and over metal, using the Texas Instruments TRF7970AEVM evaluation board. The results are:

- Over plastic:

RFID Tag	Dimensions (mm)	Interrogation Distance (mm)
Topaz512 (Type 1)	43 x 43	19
NTAG203 (Type 2)	Φ 42	21
Tag-it HFI Plus RI-I11-112	45 x 45	31
Tag-it HFI Plus RI-I02-112	76 x 48	30
Tag-it HFI Plus RI-I03-112	38 x 22.5	15
Tag-it HFI Plus RI-I16-112	Φ 24.2	20
Button type	Φ 22	19
Tag-it HFI Plus RI-I17-112	Φ 32.5	24

- Over metal:

RFID Tag	Dimensions (mm)	Interrogation Distance (mm)
Topaz512 (Type 1)	43 x 43	15
NTAG203 (Type 2)	Φ 42	16
Tag-it HFI Plus RI-I11-112	45 x 45	21
Tag-it HFI Plus RI-I02-112	76 x 48	25
Tag-it HFI Plus RI-I03-112	38 x 22.5	10
Tag-it HFI Plus RI-I16-112	Φ 24.2	13
Button type	Φ 22	15
Tag-it HFI Plus RI-I17-112	Φ 32.5	16

4. Mechanical Drawing (unit:mm)

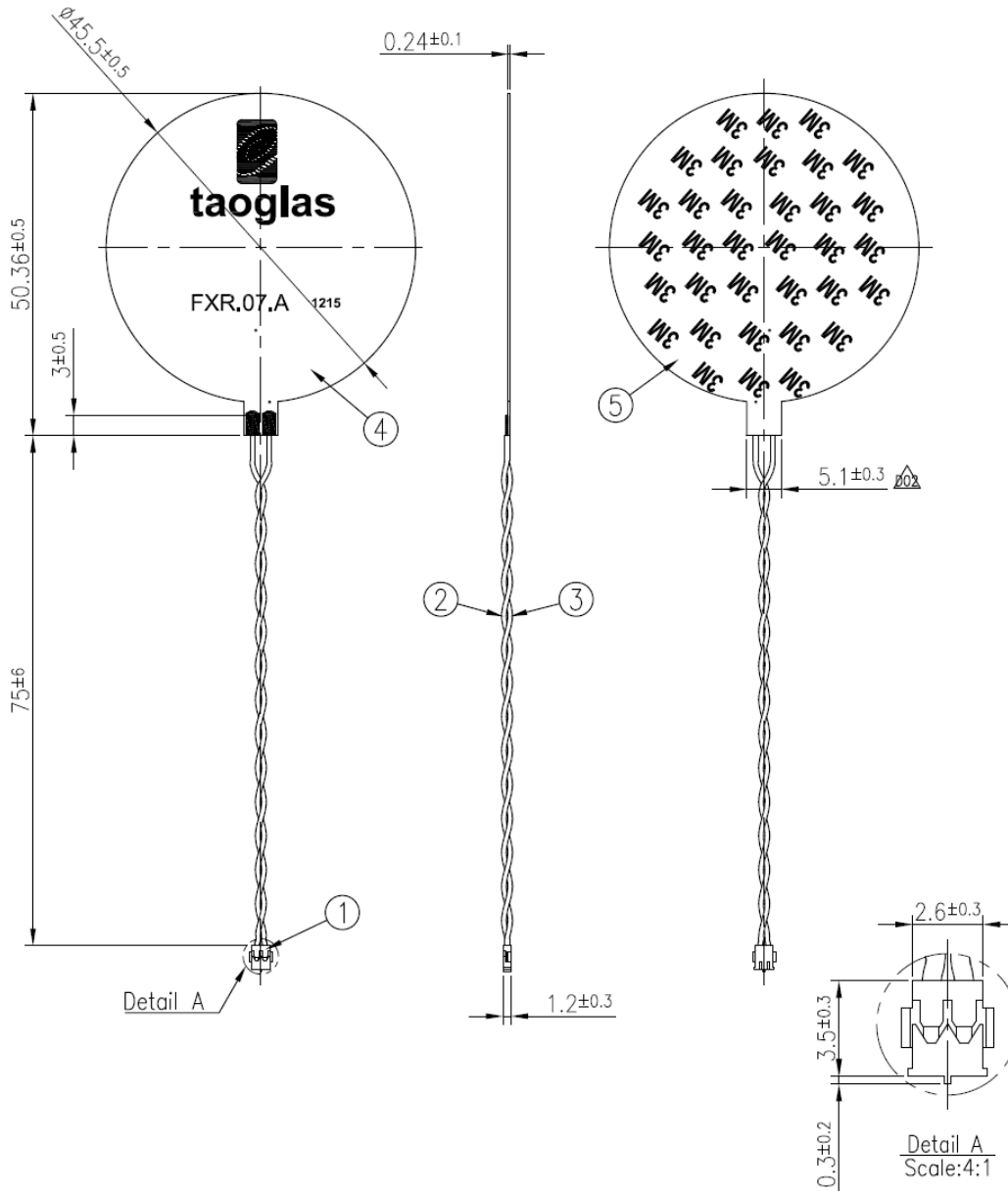

	Name	P/N	Material	Finish	QTY
1	ACH Connector (F)	208115C000000A	Engineering Plastics	Black	1
2	PVDF Cable (28AWG)	304515C000000A	PVDF	White	1
3	PVDF Cable (28AWG)	304515C010000A	PVDF	Gray	1
4	FXR.07.A.FPCB	100112G000033A	Polymer 0.15t	Black	1
5	Double-Sided Adhesive	100112G000033A	3M 467	Brown Liner	1

5. Packaging

FXR.07.52.0075X.A

Packaging Specifications

100pcs FXR.07.52.0075X.A per PE Bag
 Bag Dimensions - 187 x 137mm
 Weight - 176g

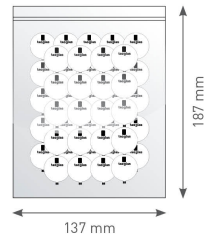

1000pcs FXR.07.52.0075X.A per PE Large Bag
 Bag Dimensions - 470 x 380mm
 Weight - 1.76Kg

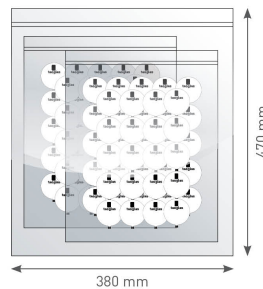

Carton Qty - 5,000 FXR.07.52.0075X.A
 Carton - 330 x 260 x 240mm
 Weight - 9.3Kg

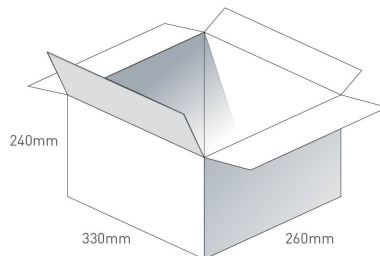

Pallet Dimensions 1200 x 1000 x 1350mm
 60 Cartons per Pallet
 12 Cartons per layer
 5 Layers

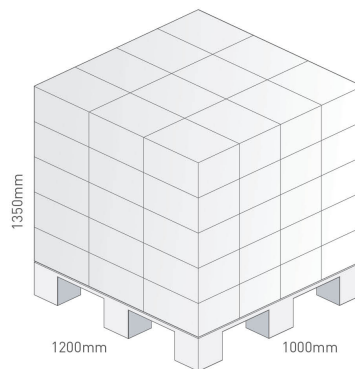



Taoglas makes no warranties based on the accuracy or completeness of the contents of this document and reserves the right to make changes to specifications and product descriptions at any time without notice. Taoglas reserves all rights to this document and the information contained herein.

Reproduction, use or disclosure to third parties without express permission is strictly prohibited.

Copyright © Taoglas Ltd.





Компания «ЭлектроПласт» предлагает заключение долгосрочных отношений при поставках импортных электронных компонентов на взаимовыгодных условиях!

Наши преимущества:

- Оперативные поставки широкого спектра электронных компонентов отечественного и импортного производства напрямую от производителей и с крупнейших мировых складов;
- Поставка более 17-ти миллионов наименований электронных компонентов;
- Поставка сложных, дефицитных, либо снятых с производства позиций;
- Оперативные сроки поставки под заказ (от 5 рабочих дней);
- Экспресс доставка в любую точку России;
- Техническая поддержка проекта, помощь в подборе аналогов, поставка прототипов;
- Система менеджмента качества сертифицирована по Международному стандарту ISO 9001;
- Лицензия ФСБ на осуществление работ с использованием сведений, составляющих государственную тайну;
- Поставка специализированных компонентов (Xilinx, Altera, Analog Devices, Intersil, Interpoint, Microsemi, Aeroflex, Peregrine, Syfer, Eurofarad, Texas Instrument, Miteq, Cobham, E2V, MA-COM, Hittite, Mini-Circuits, General Dynamics и др.);

Помимо этого, одним из направлений компании «ЭлектроПласт» является направление «Источники питания». Мы предлагаем Вам помощь Конструкторского отдела:

- Подбор оптимального решения, техническое обоснование при выборе компонента;
- Подбор аналогов;
- Консультации по применению компонента;
- Поставка образцов и прототипов;
- Техническая поддержка проекта;
- Защита от снятия компонента с производства.



Как с нами связаться

Телефон: 8 (812) 309 58 32 (многоканальный)

Факс: 8 (812) 320-02-42

Электронная почта: org@eplast1.ru

Адрес: 198099, г. Санкт-Петербург, ул. Калинина, дом 2, корпус 4, литера А.