

SLLIMM™ small low-loss intelligent molded module IPM, 3-phase inverter, 10 A, 600 V short-circuit rugged IGBT

Datasheet - production data

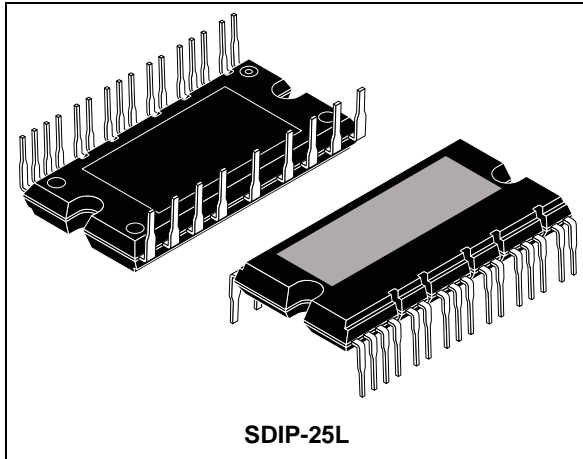

Features

- IPM 10 A, 600 V 3-phase IGBT inverter bridge including control ICs for gate driving and free-wheeling diodes
- Short-circuit rugged IGBTs
- $V_{CE(sat)}$ negative temperature coefficient
- 3.3 V, 5 V, 15 V CMOS/TTL inputs comparators with hysteresis and pull-down / pull-up resistors
- Undervoltage lockout
- Internal bootstrap diode
- Interlocking function
- Shutdown function
- DBC substrate leading to low thermal resistance
- Isolation rating of 2500 V_{rms}/min
- 4.7 k Ω NTC for temperature control
- UL recognized: UL1557 file E81734

Applications

- 3-phase inverters for motor drives
- Home appliances, such as washing machines, refrigerators, air conditioners and sewing machines

Description

This intelligent power module provides a compact, high performance AC motor drive in a simple, rugged design. Combining ST proprietary control ICs with the most advanced short-circuit-rugged IGBT system technology, this device is ideal for 3-phase inverters in applications such as home appliances and air conditioners. SLLIMM™ is a trademark of STMicroelectronics.

Table 1. Device summary

Order code	Marking	Package	Packing
STGIPS10K60T-H	GIPS10K60T-H	SDIP-25L	Tube

Contents

- 1 Internal block diagram and pin configuration 3**
- 2 Electrical ratings 5**
 - 2.1 Absolute maximum ratings 5
 - 2.2 Thermal data 6
- 3 Electrical characteristics 7**
 - 3.1 Control part 9
 - 3.1.1 NTC thermistor 11
 - 3.2 Waveform definitions 12
- 4 Applications information 13**
 - 4.1 Recommendations 14
- 5 Package information 15**
 - 5.1 SDIP-25L package information 15
 - 5.2 Packing information 17
- 6 Revision history 18**

1 Internal block diagram and pin configuration

Figure 1. Internal block diagram

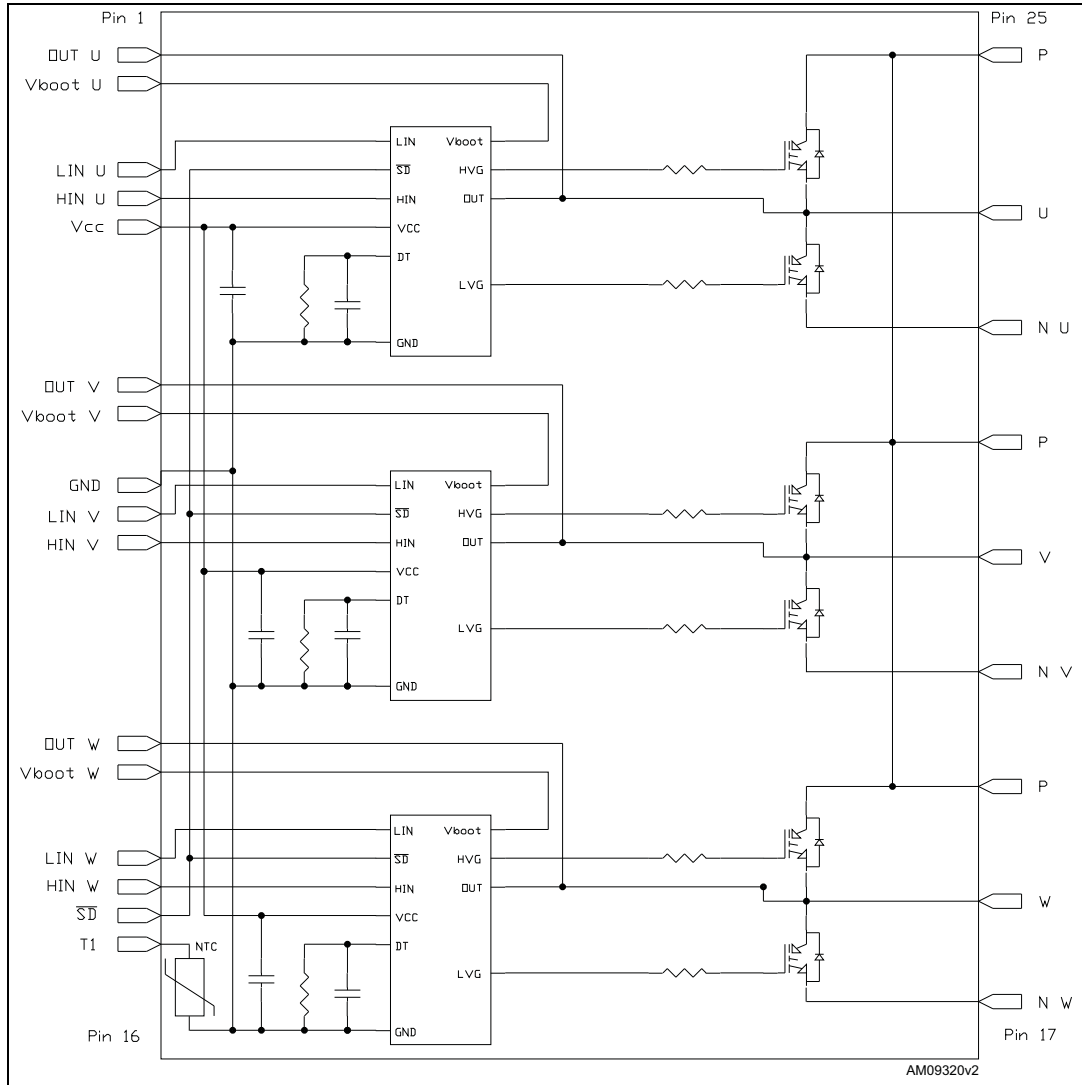
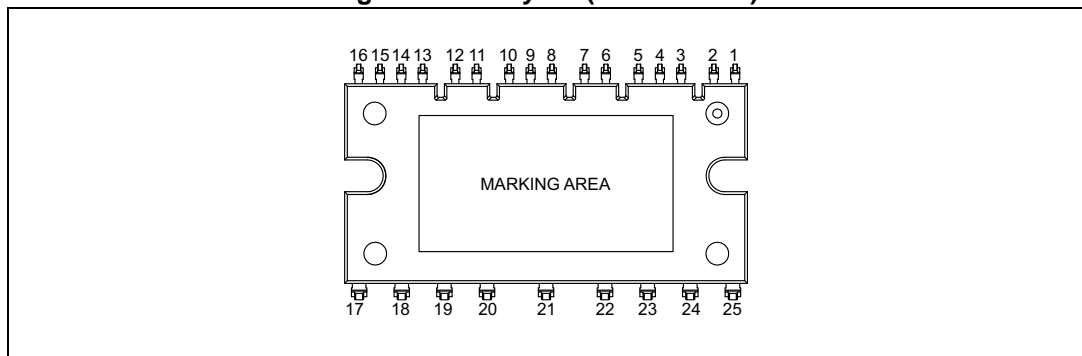

Table 2. Pin description

Pin n°	Symbol	Description
1	OUT _U	High side reference output for U phase
2	V _{boot U}	Bootstrap voltage for U phase
3	LIN _U	Low side logic input for U phase
4	HIN _U	High side logic input for U phase
5	V _{CC}	Low voltage power supply
6	OUT _V	High side reference output for V phase
7	V _{boot V}	Bootstrap voltage for V phase
8	GND	Ground
9	LIN _V	Low side logic input for V phase
10	HIN _V	High side logic input for V phase
11	OUT _W	High side reference output for W phase
12	V _{boot W}	Bootstrap voltage for W phase
13	LIN _W	Low side logic input for W phase
14	HIN _W	High side logic input for W phase
15	SD	Shut down logic input (active low)
16	T1	NTC thermistor terminal
17	N _W	Negative DC input for W phase
18	W	W phase output
19	P	Positive DC input
20	N _V	Negative DC input for V phase
21	V	V phase output
22	P	Positive DC input
23	N _U	Negative DC input for U phase
24	U	U phase output
25	P	Positive DC input

Figure 2. Pin layout (bottom view)



2 Electrical ratings

2.1 Absolute maximum ratings

Table 3. Inverter part

Symbol	Parameter	Value	Unit
V_{PN}	Supply voltage applied between P - N_U , N_V , N_W	450	V
$V_{PN(surge)}$	Supply voltage (surge) applied between P - N_U , N_V , N_W	500	V
V_{CES}	Each IGBT collector emitter voltage ($V_{IN}^{(1)} = 0$)	600	V
$\pm I_C^{(2)}$	Each IGBT continuous collector current at $T_C = 25^\circ\text{C}$	10	A
$\pm I_{CP}^{(3)}$	Each IGBT pulsed collector current	20	A
P_{TOT}	Each IGBT total dissipation at $T_C = 25^\circ\text{C}$	33	W
t_{scw}	Short-circuit withstand time, $V_{CE} = 0.5 V_{(BR)CES}$ $T_j = 125^\circ\text{C}$, $V_{CC} = V_{boot} = 15\text{ V}$, $V_{IN(1)} = 5\text{ V}$	5	μs

1. Applied between HIN_i , LIN_i and G_{ND} for $i = U, V, W$.
2. Calculated according to the iterative formula:

$$I_C(T_C) = \frac{T_{j(max)} - T_C}{R_{thj-c} \times V_{CE(sat)(max)}(T_{j(max)}, I_C(T_C))}$$

3. Pulse width limited by max junction temperature.

Table 4. Control part

Symbol	Parameter	Min.	Max.	Unit
V_{OUT}	Output voltage applied between OUT_U , OUT_V , OUT_W - GND	$V_{boot} - 21$	$V_{boot} + 0.3$	V
V_{CC}	Low voltage power supply	- 0.3	21	V
V_{boot}	Bootstrap voltage	- 0.3	620	V
V_{IN}	Logic input voltage applied between HIN , LIN and GND	- 0.3	15	V
V_{SD}	Open drain voltage	- 0.3	15	V
dV_{OUT}/dt	Allowed output slew rate		50	V/ns

Table 5. Total system

Symbol	Parameter	Value	Unit
V_{ISO}	Isolation withstand voltage applied between each pin and heatsink plate (AC voltage, $t = 60\text{ sec.}$)	2500	V
T_C	Module case operation temperature	-40 to 125	$^\circ\text{C}$
T_J	Power chips operating junction temperature	-40 to 150	$^\circ\text{C}$

2.2 Thermal data

Table 6. Thermal data

Symbol	Parameter	Value	Unit
R_{thJC}	Thermal resistance junction-case single IGBT max.	3.8	°C/W
	Thermal resistance junction-case single diode max.	5.5	°C/W

3 Electrical characteristics

$T_J = 25\text{ °C}$ unless otherwise specified.

Table 7. Inverter part

Symbol	Parameter	Test conditions	Value			Unit
			Min.	Typ.	Max.	
$V_{CE(sat)}$	Collector-emitter saturation voltage	$V_{CC} = V_{boot} = 15\text{ V}$, $V_{IN}^{(1)} = 5\text{ V}$, $I_C = 5\text{ A}$	-	2.1	2.5	V
		$V_{CC} = V_{boot} = 15\text{ V}$, $V_{IN}^{(1)} = 5\text{ V}$, $I_C = 5\text{ A}$, $T_J = 125\text{ °C}$	-	1.8		
I_{CES}	Collector-cut off current ($V_{IN}^{(1)} = 0$ "logic state")	$V_{CE} = 550\text{ V}$ $V_{CC} = V_{boot} = 15\text{ V}$	-		150	μA
V_F	Diode forward voltage	($V_{IN}^{(1)} = 0$ "logic state"), $I_C = 5\text{ A}$	-		1.9	V
Inductive load switching time and energy						
t_{on}	Turn-on time	$V_{DD} = 300\text{ V}$, $V_{CC} = V_{boot} = 15\text{ V}$, $V_{IN}^{(1)} = 0 \div 5\text{ V}$, $I_C = 5\text{ A}$ (see Figure 4)	-	320	-	ns
$t_{c(on)}$	Crossover time (on)		-	70	-	
t_{off}	Turn-off time		-	430	-	
$t_{c(off)}$	Crossover time (off)		-	135	-	
t_{rr}	Reverse recovery time		-	130	-	
E_{on}	Turn-on switching losses		-	65	-	μJ
E_{off}	Turn-off switching losses		-	75	-	

1. Applied between HIN_i , LIN_i and GND for $i = U, V, W$.

Note: t_{ON} and t_{OFF} include the propagation delay time of the internal drive. $t_{C(ON)}$ and $t_{C(OFF)}$ are the switching time of IGBT itself under the internally given gate driving condition.

Figure 3. Switching time test circuit

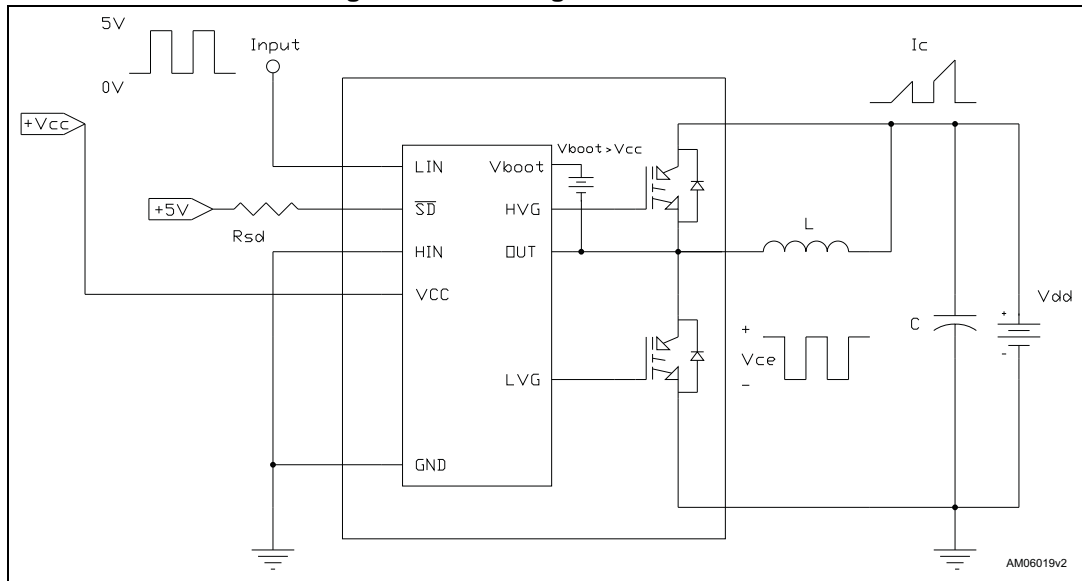
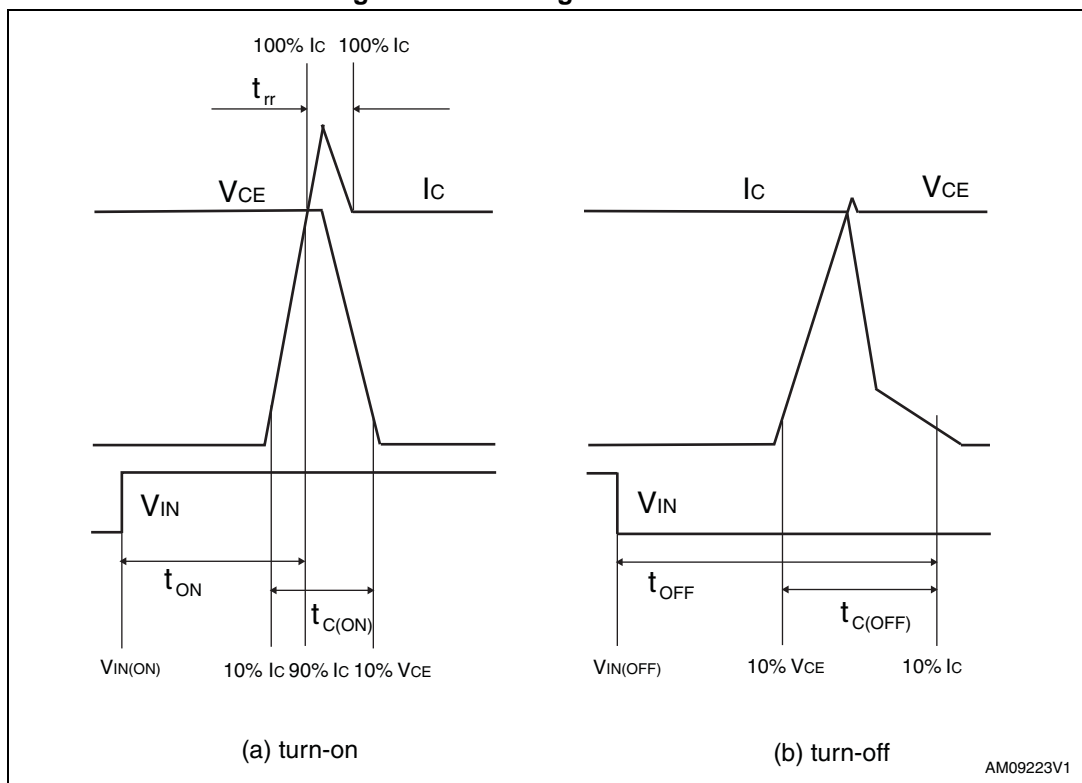

Figure 4. Switching time definition



Note: Figure 4 "Switching time definition" refers to HIN, LIN inputs (active high).

3.1 Control part

Table 8. Low voltage power supply ($V_{CC} = 15\text{ V}$ unless otherwise specified)

Symbol	Parameter	Test conditions	Min.	Typ.	Max.	Unit
V_{CC_hys}	V_{CC} UV hysteresis		1.2	1.5	1.8	V
V_{CC_thON}	V_{CC} UV turn ON threshold		11.5	12	12.5	V
V_{CC_thOFF}	V_{CC} UV turn OFF threshold		10	10.5	11	V
I_{qccu}	Undervoltage quiescent supply current	$V_{CC} = 10\text{ V}$ $\overline{SD} = 5\text{ V}; LIN = 0\text{ V};$ $H_{IN} = 0$			450	μA
I_{qcc}	Quiescent current	$V_{CC} = 15\text{ V}$ $\overline{SD} = 5\text{ V}; LIN = 0\text{ V}$ $H_{IN} = 0$			3.5	mA

Table 9. Bootstrapped voltage ($V_{CC} = 15\text{ V}$ unless otherwise specified)

Symbol	Parameter	Test conditions	Min.	Typ.	Max.	Unit
V_{BS_hys}	V_{BS} UV hysteresis		1.2	1.5	1.8	V
V_{BS_thON}	V_{BS} UV turn ON threshold		11.1	11.5	12.1	V
V_{BS_thOFF}	V_{BS} UV turn OFF threshold		9.8	10	10.6	V
I_{QBSU}	Undervoltage V_{BS} quiescent current	$V_{BS} = 9\text{ V}$ $\overline{SD} = 5\text{ V}; LIN = 0$ $H_{IN} = 5\text{ V}$		70	110	μA
I_{QBS}	V_{BS} quiescent current	$V_{BS} = 15\text{ V}$ $\overline{SD} = 5\text{ V}; LIN = 0$ $H_{IN} = 5\text{ V}$		200	300	μA
$R_{DS(on)}$	Bootstrap driver on resistance	LVG ON		120		W

Table 10. Logic inputs ($V_{CC} = 15\text{ V}$ unless otherwise specified)

Symbol	Parameter	Test conditions	Min.	Typ.	Max.	Unit
V_{il}	Low logic level voltage		0.8		1.1	V
V_{ih}	High logic level voltage		1.9		2.25	V
I_{HINh}	HIN logic "1" input bias current	$H_{IN} = 15\text{ V}$	20	40	100	μA
I_{HINl}	HIN logic "0" input bias current	$H_{IN} = 0\text{ V}$			1	μA
I_{LINh}	LIN logic "1" input bias current	$LIN = 15\text{ V}$	20	40	100	μA
I_{LINl}	LIN logic "0" input bias current	$LIN = 0\text{ V}$			1	μA
I_{SDh}	\overline{SD} logic "0" input bias current	$\overline{SD} = 15\text{ V}$	30	120	300	μA
I_{SDl}	\overline{SD} logic "1" input bias current	$\overline{SD} = 0\text{ V}$			3	μA
Dt	Dead time	see Figure 9		600		ns

Table 11. Shut down characteristics ($V_{CC} = 15\text{ V}$ unless otherwise specified)

Symbol	Parameter	Test conditions	Min.	Typ.	Max.	Unit
t_{sd}	Shut down to high / low side driver propagation delay	$V_{OUT} = 0, V_{boot} = V_{CC}, V_{IN} = 0$ to 3.3 V	50	125	200	ns

Table 12. Truth table

Condition	Logic input (V_I)			Output	
	SD	LIN	HIN	LVG	HVG
Shutdown enable half-bridge tri-state	L	X	X	L	L
Interlocking half-bridge tri-state	H	H	H	L	L
0 "logic state" half-bridge tri-state	H	L	L	L	L
1 "logic state" low side direct driving	H	H	L	H	L
1 "logic state" high side direct driving	H	L	H	L	H

Note: X: don't care

Figure 5. Maximum $I_{C(RMS)}$ current vs. switching frequency ⁽¹⁾

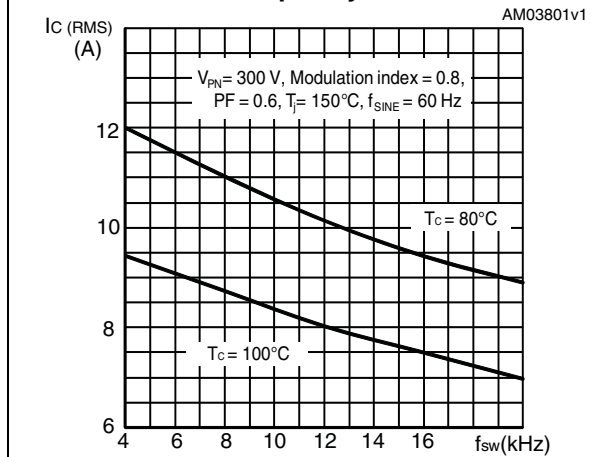
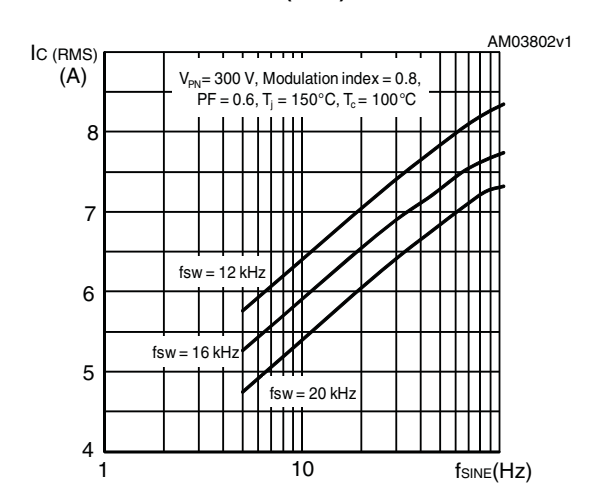

Figure 6. Maximum $I_{C(RMS)}$ current vs. f_{SINE} ⁽¹⁾



1. Simulated curves refer to typical IGBT parameters and maximum R_{thJC} .

3.1.1 NTC thermistor

Table 13. NTC thermistor

Symbol	Parameter	Test conditions	Min.	Typ.	Max.	Unit.
R ₂₅	Resistance	T = 25°C		4.7		kΩ
R ₁₂₅	Resistance	T = 125°C		160		Ω
B	B-constant	T = 25°C to 85°C		3950		K
T	Operating temperature		-40		150	°C

Equation 1: resistance variation vs. temperature

$$R(T) = R_{25} \cdot e^{B \left(\frac{1}{T} - \frac{1}{298} \right)}$$

Where T are temperatures in Kelvins

Figure 7. NTC resistance vs. temperature

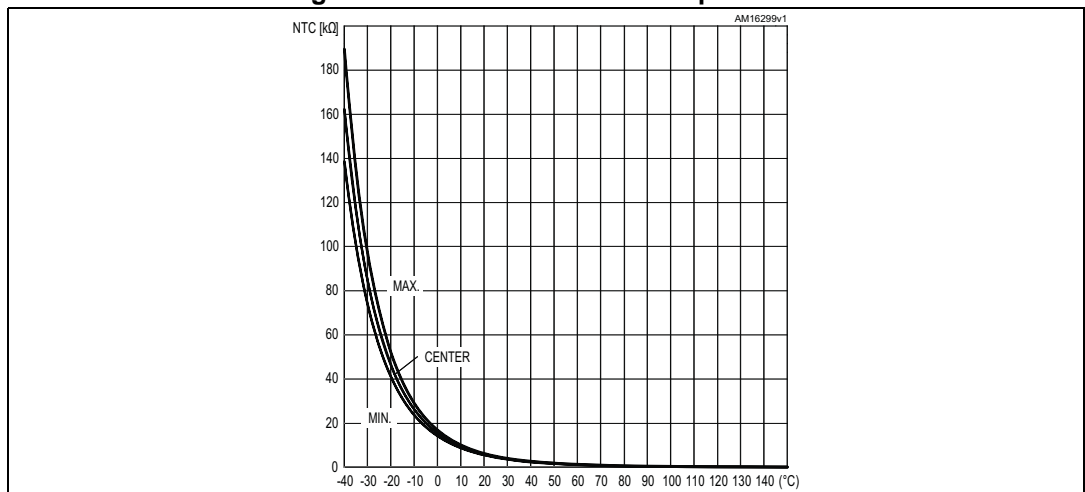
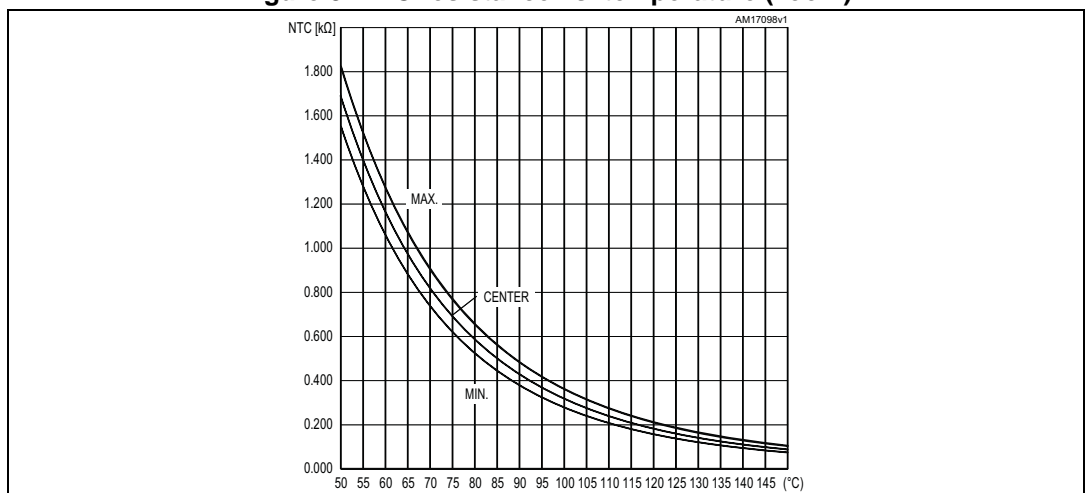
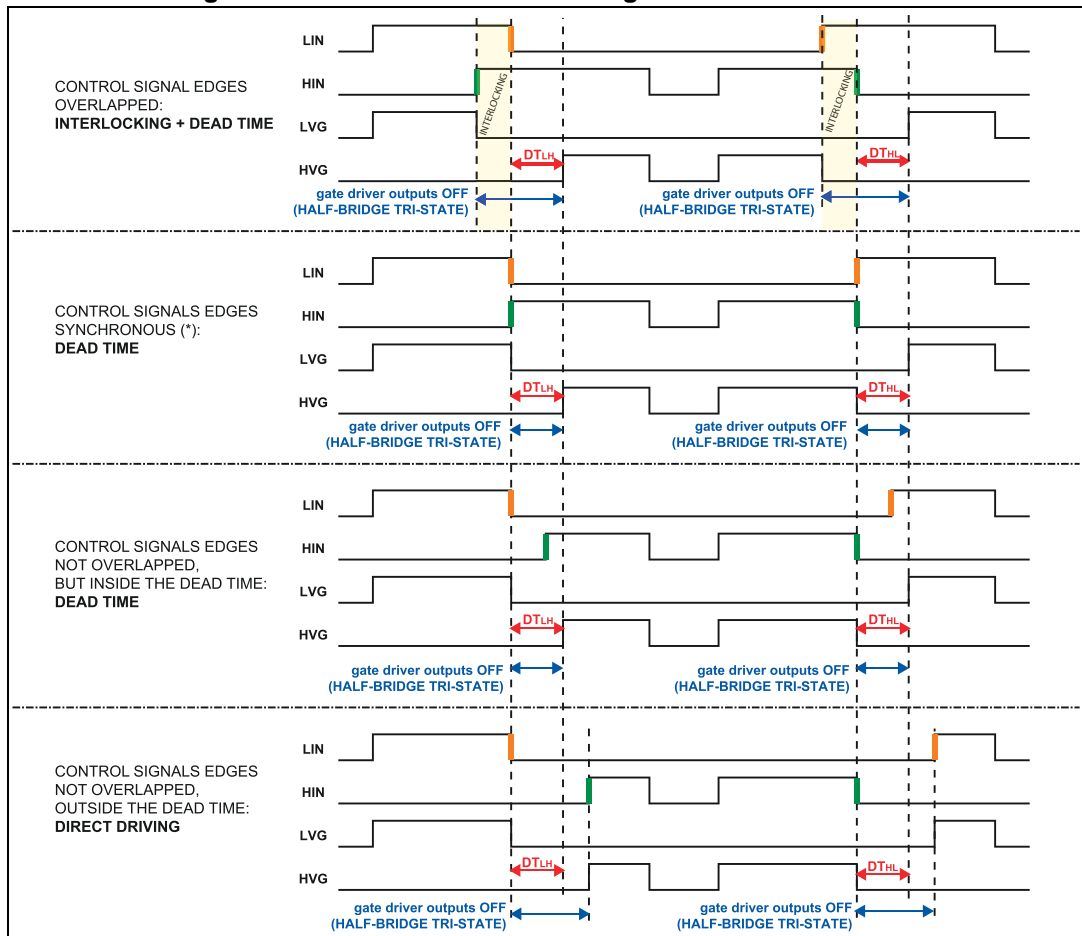

Figure 8. NTC resistance vs. temperature (zoom)



3.2 Waveform definitions

Figure 9. Dead time and interlocking waveform definitions



4 Applications information

Figure 10. Typical application circuit

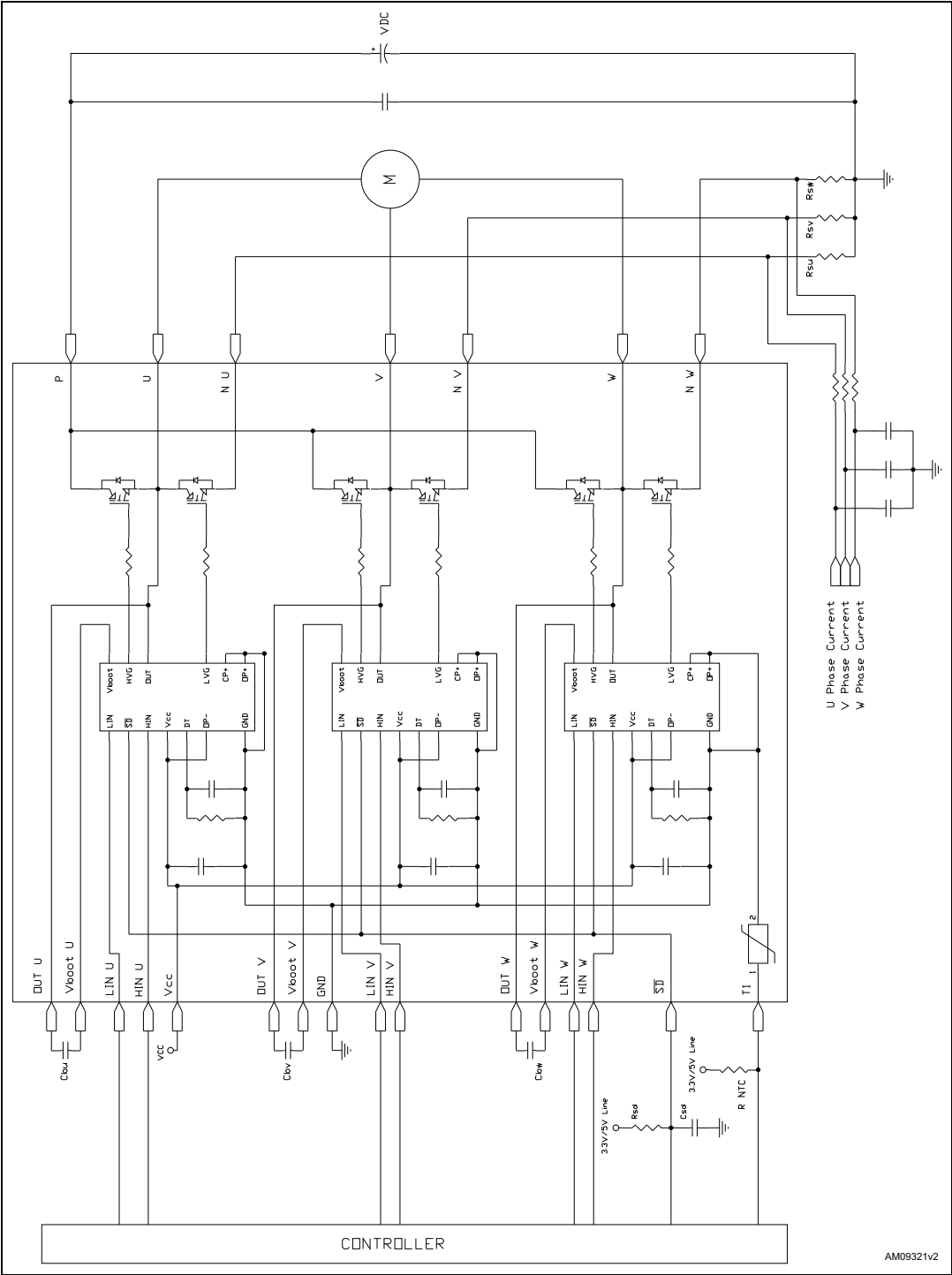

4.1 Recommendations

- Input signals HIN, LIN are active high logic. A 375 k Ω (typ.) pull down resistor is built-in for each input. If an external RC filter is used, for noise immunity, pay attention to the variation of the input signal level.
- To prevent the input signals oscillation, the wiring of each input should be as short as possible.
- By integrating an application specific type HVIC inside the module, direct coupling to MCU terminals without any opto-coupler is possible.
- Each capacitor should be located as nearby the pins of IPM as possible.
- Low inductance shunt resistors should be used for phase leg current sensing.
- Electrolytic bus capacitors should be mounted as close to the module bus terminals as possible. Additional high frequency ceramic capacitor mounted close to the module pins will further improve performance.
- The $\overline{\text{SD}}$ signal should be pulled up to 5 V / 3.3 V with an external resistor.

Table 14. Recommended operating conditions

Symbol	Parameter	Conditions	Value			Unit
			Min.	Typ.	Max.	
V_{PN}	Supply voltage	Applied between P-Nu, Nv, Nw		300	400	V
V_{CC}	Control supply voltage	Applied between V_{CC} -GND	13.5	15	18	V
V_{BS}	High side bias voltage	Applied between V_{BOOTi} - OUT_i for $i = U, V, W$	13		18	V
t_{dead}	Blanking time to prevent arm-short	For each input signal	1			μs
f_{PWM}	Pwm input signal	-40°C < T_c < 100°C -40°C < T_j < 125°C			20	kHz
T_c	Case operation temperature				100	°C

For further details refer to AN3338.

5 Package information

In order to meet environmental requirements, ST offers these devices in different grades of ECOPACK® packages, depending on their level of environmental compliance. ECOPACK® specifications, grade definitions and product status are available at: www.st.com. ECOPACK® is an ST trademark.

Please refer to dedicated technical note TN0107 for mounting instructions.

5.1 SDIP-25L package information

Figure 11. SDIP-25L package outline

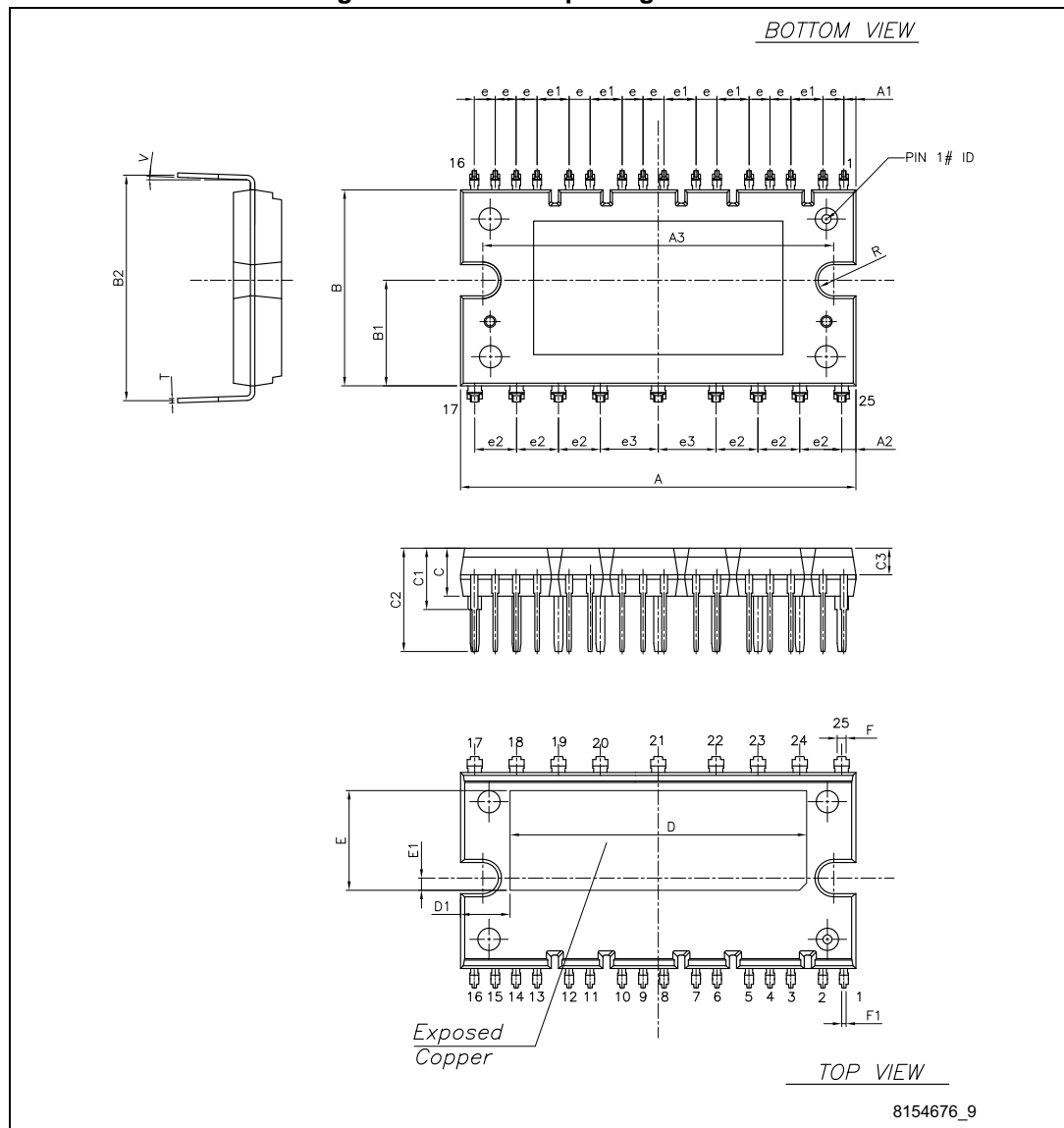
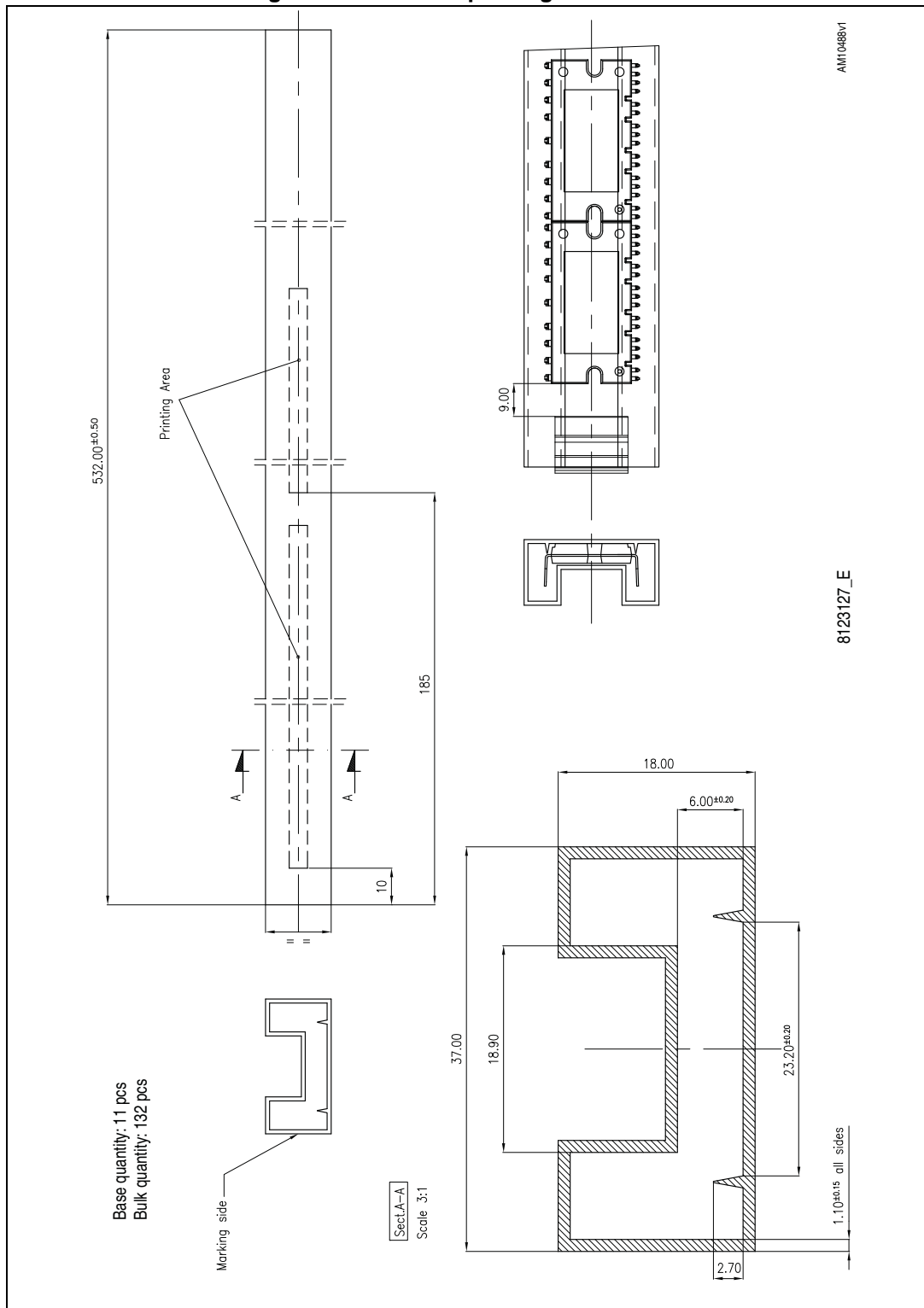

Table 15. SDIP-25L mechanical data

Dim.	mm		
	Min.	Typ.	Max.
A	43.90	44.40	44.90
A1	1.15	1.35	1.55
A2	1.40	1.60	1.80
A3	38.90	39.40	39.90
B	21.50	22.00	22.50
B1	11.25	11.85	12.45
B2	24.83	25.23	25.63
C	5.00	5.40	6.00
C1	6.50	7.00	7.50
C2	11.20	11.70	12.20
C3	2.90	3.00	3.10
e	2.15	2.35	2.55
e1	3.40	3.60	3.80
e2	4.50	4.70	4.90
e3	6.30	6.50	6.70
D		33.30	
D1		5.55	
E		11.20	
E1		1.40	
F	0.85	1.00	1.15
F1	0.35	0.50	0.65
R	1.55	1.75	1.95
T	0.45	0.55	0.65
V	0°		6°

5.2 Packing information

Figure 12. SDIP-25L packing information



6 Revision history

Table 16. Document revision history

Date	Revision	Changes
18-Jan-2013	1	Initial release.
15-Feb-2013	2	Added Inductive load typical value Table 7 on page 7 and Figure 8 on page 11 . Modified Figure 3 on page 8 and Figure 7 on page 11 .
05-Mar-2013	3	Modified Figure 7 and Figure 8 on page 11 .
15-Apr-2014	4	Document status changed from preliminary to production data. Updated Figure 2: Pin layout (bottom view) .
14-Apr-2015	5	Text edits and formatting changes throughout document Updated Figure 2: Pin layout (bottom view) Updated Section 5: Package information

IMPORTANT NOTICE – PLEASE READ CAREFULLY

STMicroelectronics NV and its subsidiaries ("ST") reserve the right to make changes, corrections, enhancements, modifications, and improvements to ST products and/or to this document at any time without notice. Purchasers should obtain the latest relevant information on ST products before placing orders. ST products are sold pursuant to ST's terms and conditions of sale in place at the time of order acknowledgement.

Purchasers are solely responsible for the choice, selection, and use of ST products and ST assumes no liability for application assistance or the design of Purchasers' products.

No license, express or implied, to any intellectual property right is granted by ST herein.

Resale of ST products with provisions different from the information set forth herein shall void any warranty granted by ST for such product.

ST and the ST logo are trademarks of ST. All other product or service names are the property of their respective owners.

Information in this document supersedes and replaces information previously supplied in any prior versions of this document.

© 2015 STMicroelectronics – All rights reserved



Компания «ЭлектроПласт» предлагает заключение долгосрочных отношений при поставках импортных электронных компонентов на взаимовыгодных условиях!

Наши преимущества:

- Оперативные поставки широкого спектра электронных компонентов отечественного и импортного производства напрямую от производителей и с крупнейших мировых складов;
- Поставка более 17-ти миллионов наименований электронных компонентов;
- Поставка сложных, дефицитных, либо снятых с производства позиций;
- Оперативные сроки поставки под заказ (от 5 рабочих дней);
- Экспресс доставка в любую точку России;
- Техническая поддержка проекта, помощь в подборе аналогов, поставка прототипов;
- Система менеджмента качества сертифицирована по Международному стандарту ISO 9001;
- Лицензия ФСБ на осуществление работ с использованием сведений, составляющих государственную тайну;
- Поставка специализированных компонентов (Xilinx, Altera, Analog Devices, Intersil, Interpoint, Microsemi, Aeroflex, Peregrine, Syfer, Eurofarad, Texas Instrument, Miteq, Cobham, E2V, MA-COM, Hittite, Mini-Circuits, General Dynamics и др.);

Помимо этого, одним из направлений компании «ЭлектроПласт» является направление «Источники питания». Мы предлагаем Вам помощь Конструкторского отдела:

- Подбор оптимального решения, техническое обоснование при выборе компонента;
- Подбор аналогов;
- Консультации по применению компонента;
- Поставка образцов и прототипов;
- Техническая поддержка проекта;
- Защита от снятия компонента с производства.



Как с нами связаться

Телефон: 8 (812) 309 58 32 (многоканальный)

Факс: 8 (812) 320-02-42

Электронная почта: org@eplast1.ru

Адрес: 198099, г. Санкт-Петербург, ул. Калинина, дом 2, корпус 4, литера А.