

ZXGD3104N8

SYNCHRONOUS MOSFET CONTROLLER IN SO8

Description

The ZXGD3104 is intended to drive MOSFETS configured as ideal diode replacements. The device is comprised of a differential amplifier detector stage and high current driver. The detector monitors the reverse voltage of the MOSFET such that if body diode conduction occurs a positive voltage is applied to the MOSFET's Gate pin.

Once the positive voltage is applied to the Gate the MOSFET switches on. The detectors' output voltage is then proportional to the MOSFET Drain-Source voltage and this is applied to the Gate via the driver. This action provides a rapid MOSFET turn off at zero Drain current.

Applications

- Flyback Converters in:
 - ≥90W Laptop Adaptors

Typical Configuration

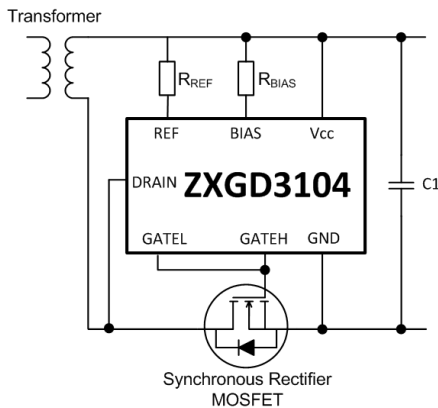

Features

- 5-25V Vcc range
- Operating up to 250kHz
- Suitable for Discontinuous Mode (DCM), Critical Conduction Mode (CrCM) and Continuous Mode (CCM) operation
- Turn-off propagation delay 15ns and turn-off time 20ns.
- Proportional Gate Drive
- Detector threshold voltage -10mV
- Standby current 5mA
- "Lead-Free", RoHS Compliant (Note 1)
- Halogen and Antimony free. "Green" Device (Note 2)
- Qualified to AEC-Q101 Standards for High Reliability

Mechanical Data

- Case: SO-8
- Case material: Molded Plastic. "Green" Molding Compound.
- UL Flammability Rating 94V-0
- Moisture Sensitivity: Level 1 per J-STD-020
- Terminals: Matte Tin Finish
- Solderable per MIL-STD-202, Method 208
- Weight: 0.074 grams (approximate)

SO-8

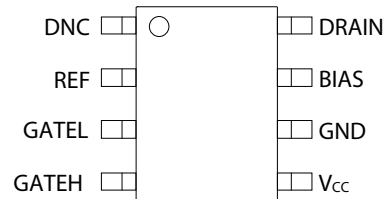

Top View
Pin-Out

Ordering Information (Note 3)

Product	Marking	Reel size (inches)	Tape width (mm)	Quantity per reel
ZXGD3104N8TC	ZXGD3104	13	12	2,500

- Notes:
1. No purposefully added lead
 2. Diodes Inc's "Green" Policy can be found on our website at <http://www.diodes.com>
 3. For packaging details, go to our website at <http://www.diodes.com>

Marking Information

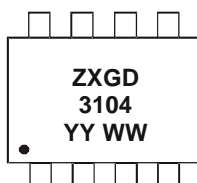

- ZXGD = Product Type Marking Code, Line 1
- 3104 = Product Type Marking Code, Line 2
- YY = Year (ex: 11 = 2011)
- WW = Week (01 - 53)

Functional Block Diagram

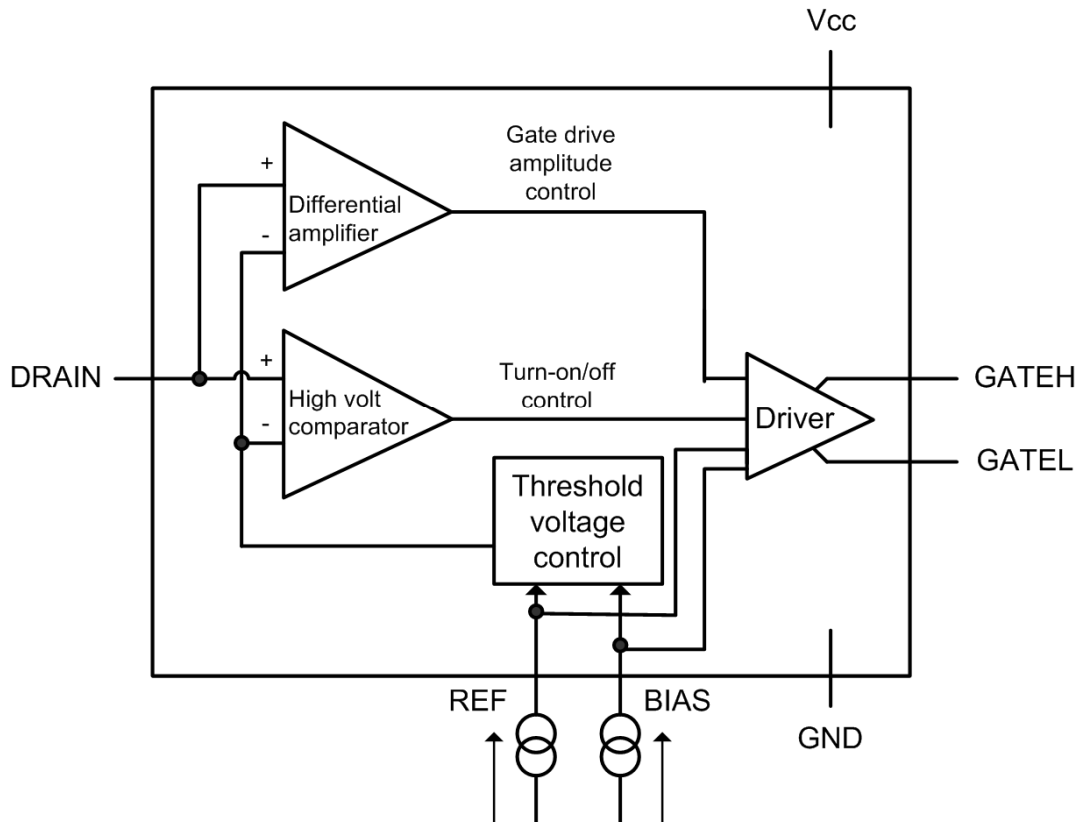

Pin No.	Name	Description and function
1	DNC	Do not connect Leave pin floating.
2	REF	Reference This pin is connected to V_{CC} via resistor, R_{REF} . Select R_{REF} to source 2.16mA into this pin. Refer to Table 1, in Application Information section.
3	GATEL	Gate turn off This pin sinks current, I_{SINK} , from the synchronous MOSFET Gate.
4	GATEH	Gate turn on This pin sources current, I_{SOURCE} , to the synchronous MOSFET Gate.
5	V_{CC}	Power Supply This is the supply pin. It is recommended to decouple this point to ground closely with a ceramic capacitor.
6	GND	Ground This is the ground reference point. Connect to the synchronous MOSFET Source terminal.
7	BIAS	Bias This pin is connected to V_{CC} via resistor, R_{BIAS} . Select R_{BIAS} to source 3mA into this pin. Refer to Table 1, in Application Information section.
8	DRAIN	Drain connection This pin connects directly to the synchronous MOSFET Drain terminal.

ZXGD3104N8

Maximum Ratings @T_A = 25°C unless otherwise specified

Characteristic	Symbol	Value	Unit
Supply voltage, relative to GND	V _{CC}	25	V
Drain pin voltage	V _D	-3 to 180	V
Gate output voltage	V _G	-3 to V _{CC} + 3	V
Gate Driver peak source current	I _{SOURCE}	2.5	A
Gate Driver peak sink current	I _{SINK}	7	A
Reference voltage	V _{REF}	V _{CC}	V
Reference current	I _{REF}	25	mA
Bias voltage	V _{BIAS}	V _{CC}	V
Bias current	I _{BIAS}	100	mA

Thermal Characteristics @T_A = 25°C unless otherwise specified

Characteristic	Symbol	Value	Unit
Power Dissipation Linear derating factor	P _D	(Note 4)	490
		(Note 5)	3.92
		(Note 6)	655
		(Note 7)	5.24
		(Note 7)	720
Thermal Resistance, Junction to Ambient	R _{θJA}	(Note 4)	5.76
		(Note 5)	785
		(Note 6)	6.28
		(Note 7)	255
Thermal Resistance, Junction to Lead	R _{θJL}	135	°C/W
Operating Temperature Range	T _J	-40 to +150	°C
Storage Temperature Range	T _{STG}	-50 to +150	

- Notes:
4. For a device surface mounted on minimum recommended pad layout FR4 PCB with high coverage of single sided 1oz copper, in still air conditions; the device is measured when operating in a steady-state condition.
 5. Same as note (4), except pin 5 (V_{CC}) and pin 6 (GND) are both connected to separate 5mm x 5mm 1oz copper heatsinks.
 6. Same as note (5), except both heatsinks are 10mm x 10mm.
 7. Same as note (5), except both heatsinks are 15mm x 15mm.
 8. Thermal resistance from junction to solder-point at the end of each lead on pin 5 (V_{CC}) and pin 6 (GND).

Thermal Derating Curve

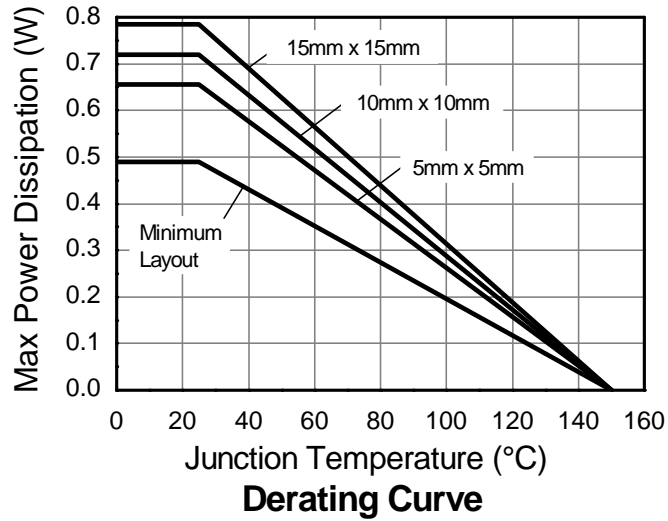

ESD Rating

Characteristic	Value	Unit
ESD for Human Body Model	2000	V
ESD for Machine Model	300	

ZXGD3104N8

Electrical Characteristics @T_A = 25°C unless otherwise specified

V_{CC} = 19V; R_{BIAS} = 6.3kΩ; R_{REF} = 8.5kΩ

Characteristic	Symbol	Min	Typ	Max	Unit	Test Condition	
Input and Supply							
Quiescent current	I _Q	-	5.16	-	mA	V _D ≥ 0V	
Gate Driver							
Turn-off Threshold Voltage (Note 9 & 10)	V _T	-16	-10	0	mV	V _G = 1V	
Gate output voltage	(Note 9 & 10)	V _{G(off)}	0	0.73	1.0	V	V _D ≥ 1V
	(Note 9 & 11)	V _G	12.5	14	V _{CC}		V _D = -50mV
			17	18	V _{CC}		V _D = -100mV
Switching Performance for Q _{G(tot)} = 124nC (Note 12)							
Turn-on propagation delay	t _{d(rise)}	175	250	325	ns	Refer to switching waveforms in Fig. 1	
Turn-off propagation delay	t _{d(fall)}	11	15	20			
Gate rise time	t _r	335	480	625			
		530	760	990			
Gate fall time	t _f	35	50	65	Continuous Conduction Mode		

- Notes:**
 9. GATEH connected to GATEL
 10. R_H = 100kΩ, R_L = O/C
 11. R_L = 100kΩ, R_H = O/C
 12. refer to test circuit below

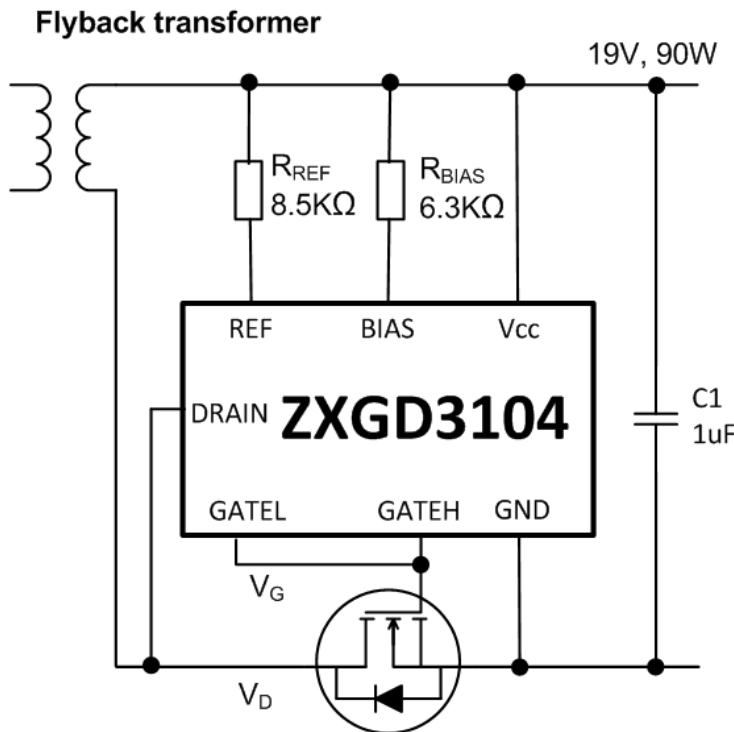

100V MOSFET
 Q_{G(tot)} = 124nC R_{DS(on)} = 8.5mΩ

Test conditions
 Primary side input voltage = 400V
 Switching frequency = 65kHz
 Discontinuous conduction mode

Descriptions of the normal operation

The operation of the controller is described step-by-step with reference to the timing diagram in Figure 1.

1. The controller monitors the MOSFET Drain-Source voltage.
2. When, due to transformer action, the MOSFET body diode is forced to conduct there is approximately -0.8V on the Drain pin.
3. The detector outputs a positive voltage with respect to ground, this voltage is then fed to the MOSFET driver stage and current is sourced out of the GATE pin.
4. The controller goes into proportional gate drive control — the GATE output voltage is proportional to the on-resistance-induced Drain-Source voltage drop across the MOSFET. Proportional gate drive ensures that MOSFET conducts for majority of the conduction cycle and minimizes body diode conduction time.
5. As the Drain current decays linearly toward zero, proportional gate drive control reduces the Gate voltage so the MOSFET can be turned off rapidly at zero current crossing. The GATE voltage is removed when the Drain-Source voltage crosses the detection threshold voltage to minimize reverse current flow.
6. At zero Drain current, the controller GATE output voltage is pulled low to $V_{G(off)}$ to ensure that the MOSFET is off.

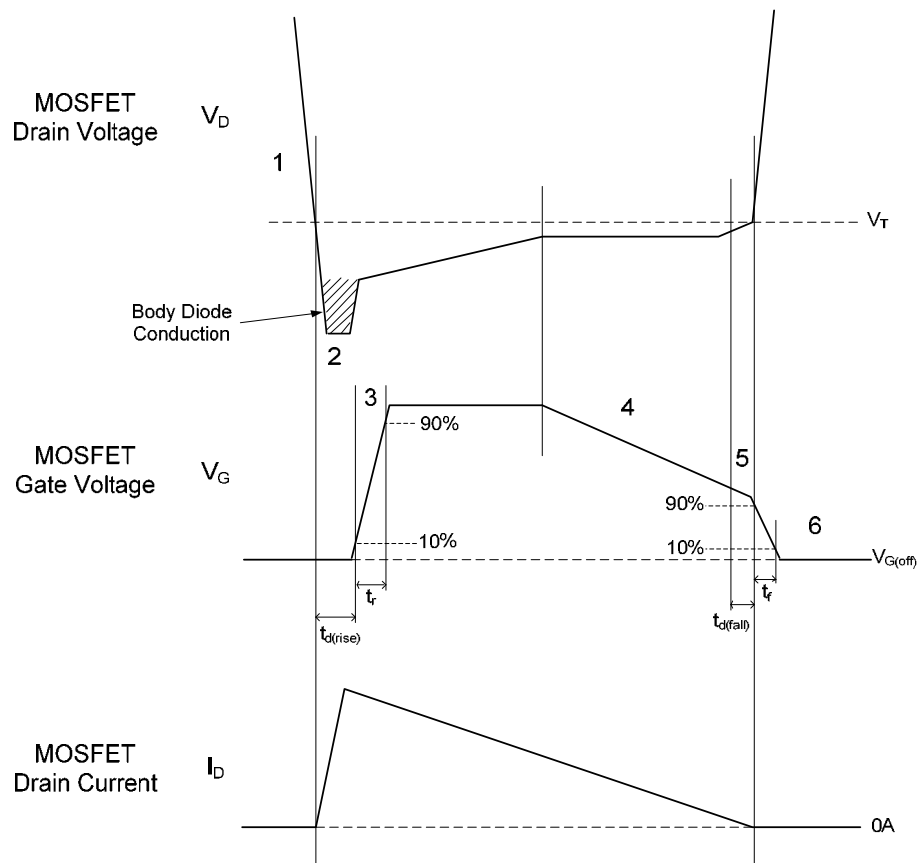
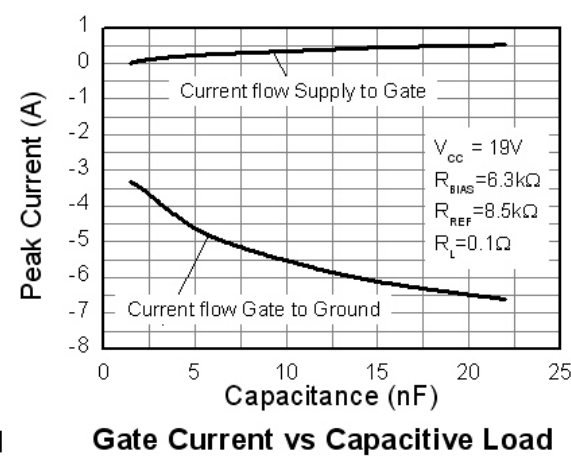
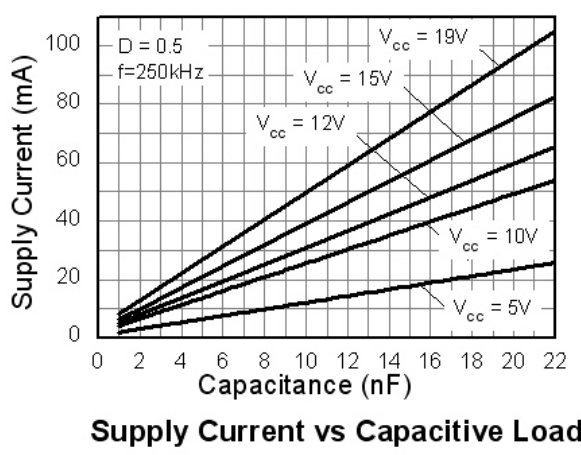
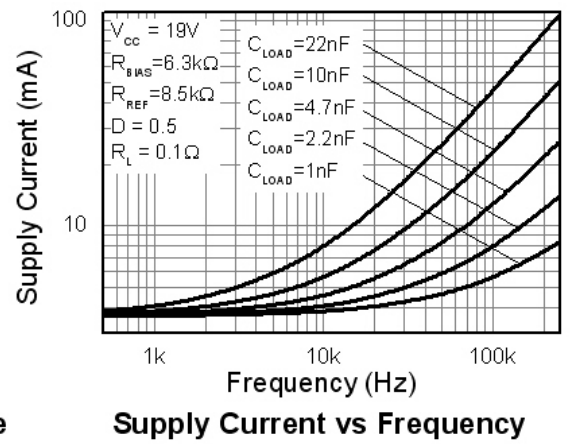
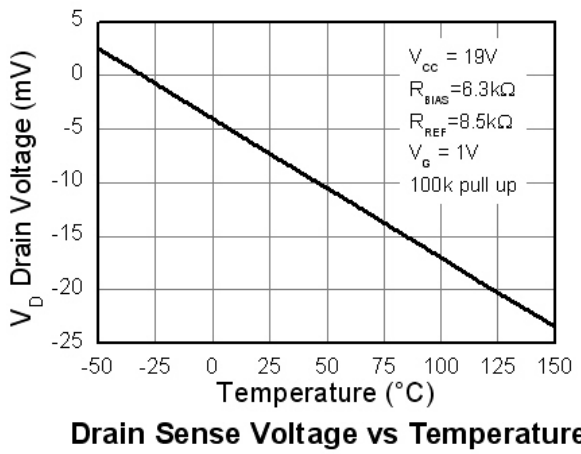
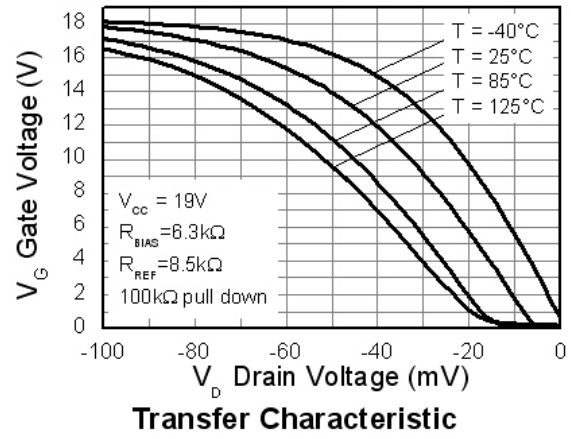
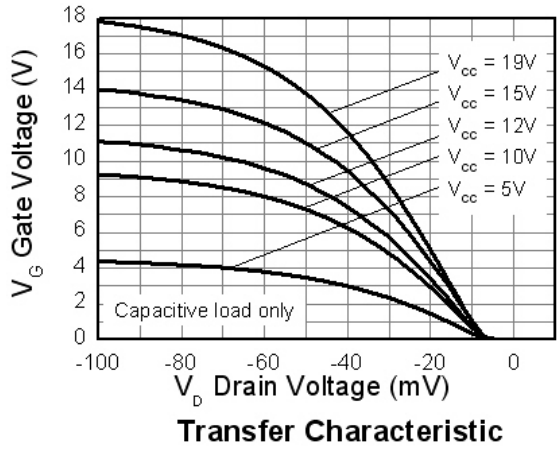
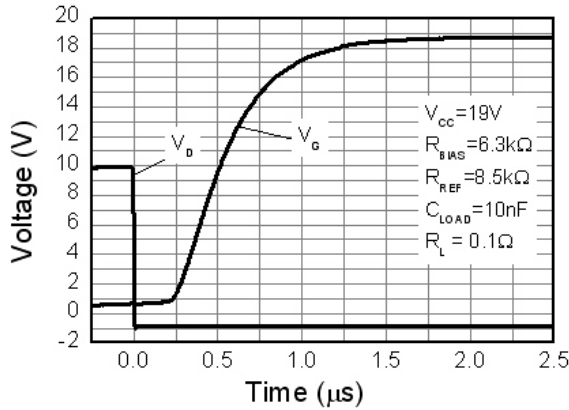

Figure 1. Timing diagram for a critical conduction mode Flyback converter

Typical Electrical Characteristics @ $T_A = 25^\circ\text{C}$ unless otherwise specified



Continued - Typical Electrical Characteristics @ $T_A = 25^\circ\text{C}$ unless otherwise specified



Switch On Speed

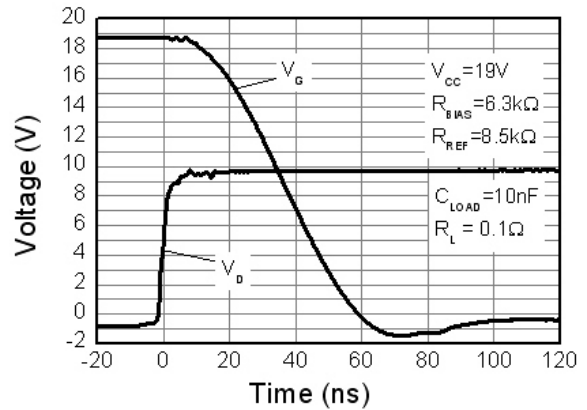

Switch Off Speed

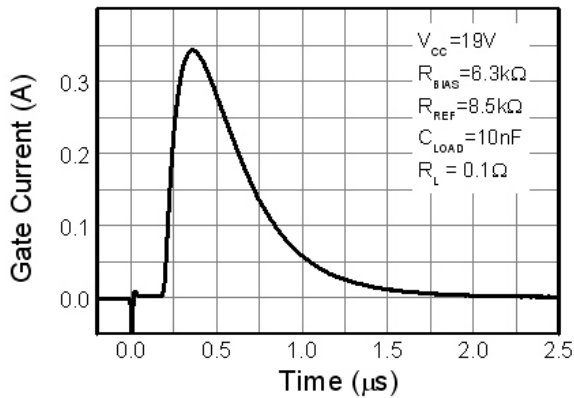

Gate Drive On Current

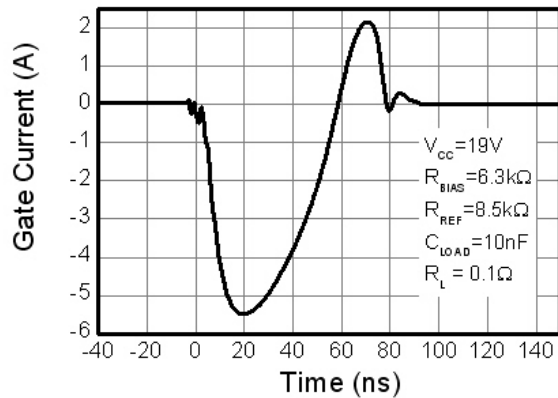

Gate Drive Off Current

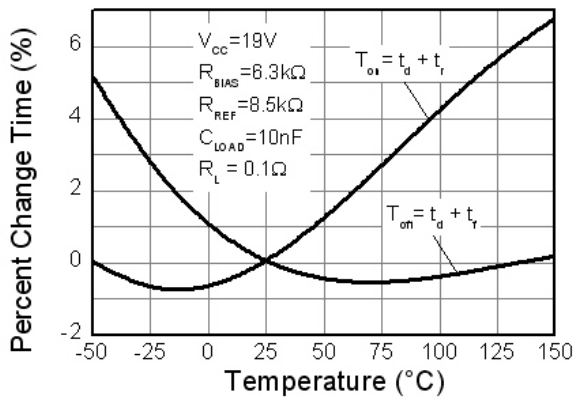

Switching vs Temperature

Application Information

The purpose of the ZXGD3104 is to drive a MOSFET as a low- V_F Schottky diode replacement in offline power converters. When combined with a low $R_{DS(ON)}$ MOSFET, it can yield significant power efficiency improvement, whilst maintaining design simplicity and incurring minimal component count. Figure 2 shows typical configuration of ZXGD3104 for synchronous rectification in a 19V output Flyback Adaptor.

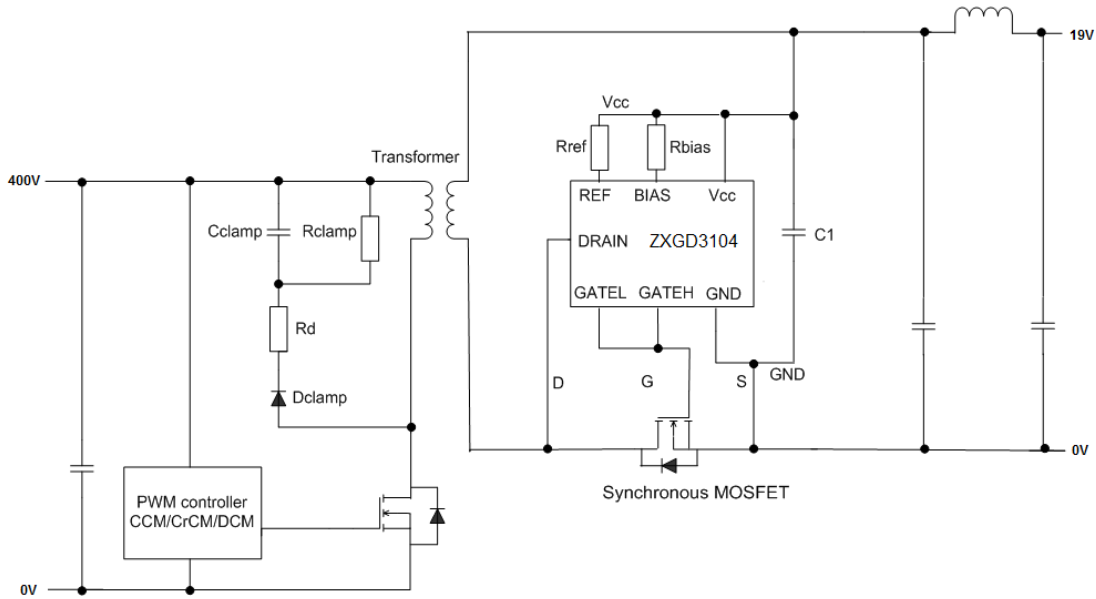

Figure 2. Example connections in Flyback power supply

Figure 3 shows operating waveforms for ZXGD3104 driving a MOSFET with $Q_{g(TOT)} = 124nC$ in a 19V output Flyback converter operating in critical conduction mode.

Typical waveforms

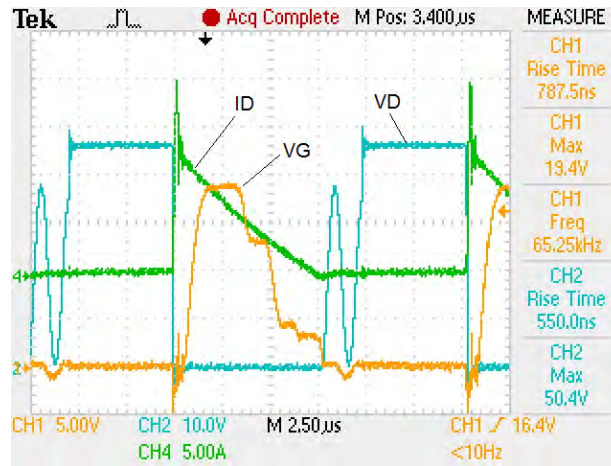

Fig 3a: Critical conduction mode, operating for MOSFET with $Q_{g(TOT)} = 124nC$

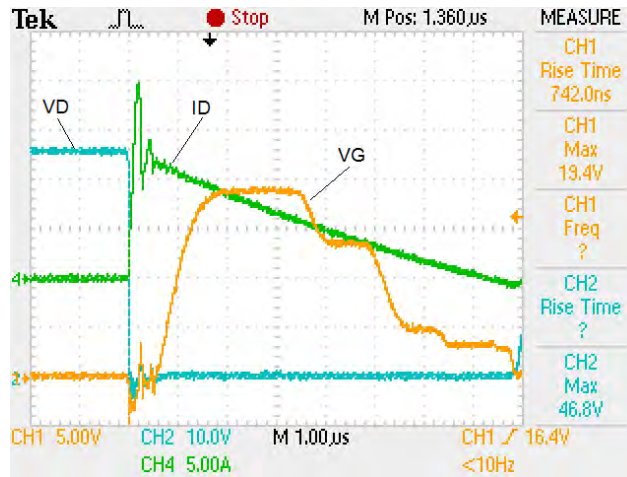

Fig 3b: Typical switching waveform

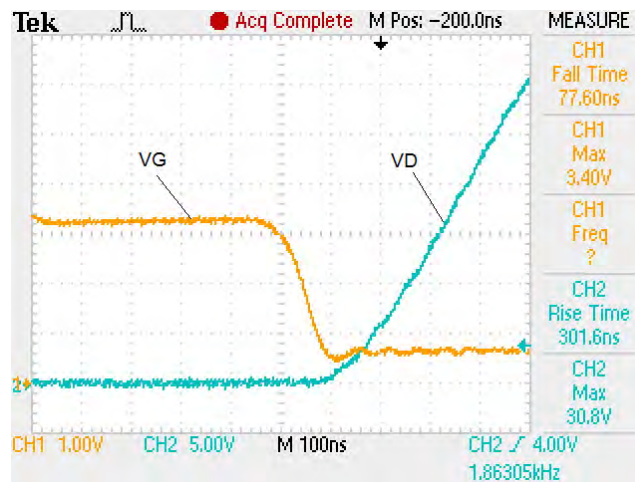

Fig 3c: Close up of typical turn off waveform

Design considerations

It is advisable to decouple the ZXGD3104 closely to V_{CC} and ground due to the possibility of high peak gate currents with a $1\mu\text{F}$ X7R type ceramic capacitor C1 as shown in Figure 2. Also the ground return loop should be as short as possible.

To minimize parasitic inductance-induced premature turn-off of the synchronous controller always keep the PCB track length between ZXGD3104's Drain input and MOSFET's Drain to less than 10mm. Low internal inductance SMD MOSFET packages are also recommended for high switching frequency power conversion to minimize MOSFET body diode conduction loss.

The Gate pins should be as close to the MOSFET's gate as possible. External gate resistors are optional. They can be inserted to control the rise and fall time which may help with EMI issues.

The careful selection of external resistors R_{REF} and R_{BIAS} is important to the optimum device operation. Select a value for resistor R_{REF} and R_{BIAS} from Table 1 based on the desired V_{CC} value. This provides the typical ZXGD3104's detection threshold voltage of -10mV.

Table 1. Recommended resistor values for various supply voltages

V_{CC}	R_{BIAS}	R_{REF}
5V	1.6 k Ω	2 k Ω
10V	3.3 k Ω	4.3 k Ω
12V	3.9 k Ω	5.1 k Ω
15V	5.1 k Ω	6.8 k Ω
19V	6.3 k Ω	8.5 k Ω

Package Outline Dimensions

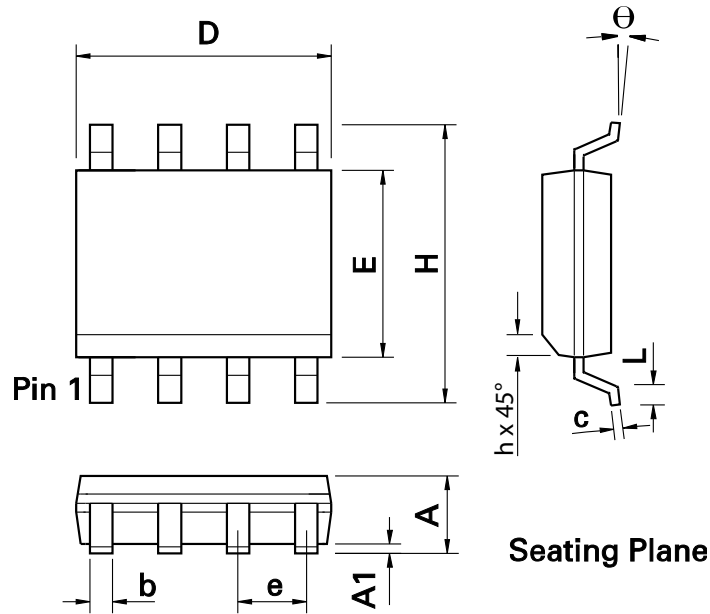

DIM	Inches		Millimeters		DIM	Inches		Millimeters	
	Min.	Max.	Min.	Max.		Min.	Max.	Min.	Max.
A	0.053	0.069	1.35	1.75	e	0.050 BSC		1.27 BSC	
A1	0.004	0.010	0.10	0.25	b	0.013	0.020	0.33	0.51
D	0.189	0.197	4.80	5.00	c	0.008	0.010	0.19	0.25
H	0.228	0.244	5.80	6.20	θ	0°	8°	0°	8°
E	0.150	0.157	3.80	4.00	h	0.010	0.020	0.25	0.50
L	0.016	0.050	0.40	1.27	-	-	-	-	-

Suggested Pad Layout

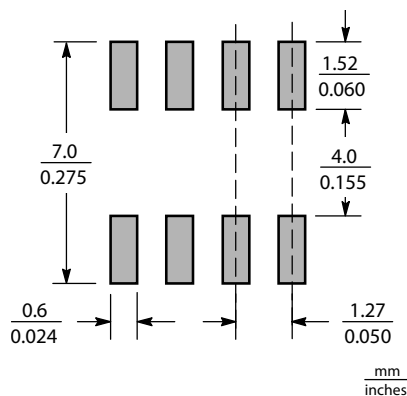

IMPORTANT NOTICE

DIODES INCORPORATED MAKES NO WARRANTY OF ANY KIND, EXPRESS OR IMPLIED, WITH REGARDS TO THIS DOCUMENT, INCLUDING, BUT NOT LIMITED TO, THE IMPLIED WARRANTIES OF MERCHANTABILITY AND FITNESS FOR A PARTICULAR PURPOSE (AND THEIR EQUIVALENTS UNDER THE LAWS OF ANY JURISDICTION).

Diodes Incorporated and its subsidiaries reserve the right to make modifications, enhancements, improvements, corrections or other changes without further notice to this document and any product described herein. Diodes Incorporated does not assume any liability arising out of the application or use of this document or any product described herein; neither does Diodes Incorporated convey any license under its patent or trademark rights, nor the rights of others. Any Customer or user of this document or products described herein in such applications shall assume all risks of such use and will agree to hold Diodes Incorporated and all the companies whose products are represented on Diodes Incorporated website, harmless against all damages.

Diodes Incorporated does not warrant or accept any liability whatsoever in respect of any products purchased through unauthorized sales channel. Should Customers purchase or use Diodes Incorporated products for any unintended or unauthorized application, Customers shall indemnify and hold Diodes Incorporated and its representatives harmless against all claims, damages, expenses, and attorney fees arising out of, directly or indirectly, any claim of personal injury or death associated with such unintended or unauthorized application.

Products described herein may be covered by one or more United States, international or foreign patents pending. Product names and markings noted herein may also be covered by one or more United States, international or foreign trademarks.

LIFE SUPPORT

Diodes Incorporated products are specifically not authorized for use as critical components in life support devices or systems without the express written approval of the Chief Executive Officer of Diodes Incorporated. As used herein:

A. Life support devices or systems are devices or systems which:

1. are intended to implant into the body, or
2. support or sustain life and whose failure to perform when properly used in accordance with instructions for use provided in the labeling can be reasonably expected to result in significant injury to the user.

B. A critical component is any component in a life support device or system whose failure to perform can be reasonably expected to cause the failure of the life support device or to affect its safety or effectiveness.

Customers represent that they have all necessary expertise in the safety and regulatory ramifications of their life support devices or systems, and acknowledge and agree that they are solely responsible for all legal, regulatory and safety-related requirements concerning their products and any use of Diodes Incorporated products in such safety-critical, life support devices or systems, notwithstanding any devices- or systems-related information or support that may be provided by Diodes Incorporated. Further, Customers must fully indemnify Diodes Incorporated and its representatives against any damages arising out of the use of Diodes Incorporated products in such safety-critical, life support devices or systems.

Copyright © 2011, Diodes Incorporated

www.diodes.com



Компания «ЭлектроПласт» предлагает заключение долгосрочных отношений при поставках импортных электронных компонентов на взаимовыгодных условиях!

Наши преимущества:

- Оперативные поставки широкого спектра электронных компонентов отечественного и импортного производства напрямую от производителей и с крупнейших мировых складов;
- Поставка более 17-ти миллионов наименований электронных компонентов;
- Поставка сложных, дефицитных, либо снятых с производства позиций;
- Оперативные сроки поставки под заказ (от 5 рабочих дней);
- Экспресс доставка в любую точку России;
- Техническая поддержка проекта, помощь в подборе аналогов, поставка прототипов;
- Система менеджмента качества сертифицирована по Международному стандарту ISO 9001;
- Лицензия ФСБ на осуществление работ с использованием сведений, составляющих государственную тайну;
- Поставка специализированных компонентов (Xilinx, Altera, Analog Devices, Intersil, Interpoint, Microsemi, Aeroflex, Peregrine, Syfer, Eurofarad, Texas Instrument, Miteq, Cobham, E2V, MA-COM, Hittite, Mini-Circuits, General Dynamics и др.);

Помимо этого, одним из направлений компании «ЭлектроПласт» является направление «Источники питания». Мы предлагаем Вам помощь Конструкторского отдела:

- Подбор оптимального решения, техническое обоснование при выборе компонента;
- Подбор аналогов;
- Консультации по применению компонента;
- Поставка образцов и прототипов;
- Техническая поддержка проекта;
- Защита от снятия компонента с производства.



Как с нами связаться

Телефон: 8 (812) 309 58 32 (многоканальный)

Факс: 8 (812) 320-02-42

Электронная почта: org@eplast1.ru

Адрес: 198099, г. Санкт-Петербург, ул. Калинина, дом 2, корпус 4, литера А.