

## 2 x 35 W power amplifier for car radio

### Features

- High output power capability:
  - 2 x 40 W max./4  $\Omega$
  - 2 x 35 W/4  $\Omega$  EIAJ
  - 2 x 25 W/4  $\Omega$  @14.4 V, 1 kHz, 10 %
  - 2 x 25 W/2  $\Omega$  @14.4 V, 1 kHz, 10 %
- 2  $\Omega$  driving
- Differential inputs
- Minimum external components count
- Internally fixed gain (26 dB)
- Mute function (CMOS compatible)
- Automute at minimum supply voltage detection
- Standby function
- No audible pop during mute and standby operations
- Clipping detector with programmable distortion threshold
- Protections:
  - Short circuit (out to ground, out to supply voltage, across the load)
  - Overrating chip temperature with soft thermal limiter
  - Load dump voltage
  - Fortuitous open ground
  - Loudspeaker DC current
  - ESD

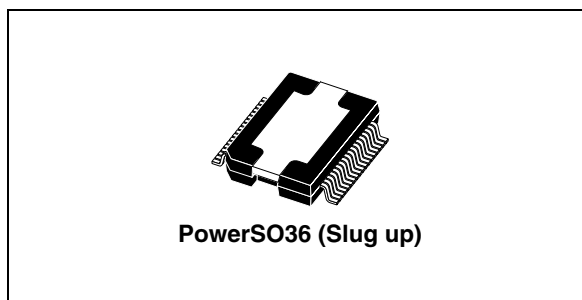

### Description

The TDA7376PD is a new technology dual bridge audio amplifier in PowerSO36 package designed for car radio applications.

Thanks to the fully complementary PNP/NPN output stage configuration the TDA7376PD delivers a rail-to-rail voltage swing with no need of bootstrap capacitors.

Differential input pairs, that will accept either single ended or differential input signals, guarantee high noise immunity making the device suitable for both car radio and car boosters applications.

The audio mute control, that attenuates the output signal of the audio amplifiers, suppresses pop on - off transients and cuts any noises coming from previous stages. The standby control, that de-biases the amplifiers, reduces the cost of the power switch. The on-board programmable distortion detector allows compression facility whenever the amplifier is overdriven, so limiting the distortion at any levels inside the presettable range.

**Table 1. Device summary**

Order code	Package	Packing
TDA7376PD	PowerSO36	Tube
TDA7376PDTR	PowerSO36	Tape and reel

# Contents

- 1      Block and pins connection diagrams ..... 5**
  
- 2      Electrical specifications ..... 6**
  - 2.1    Absolute maximum ratings ..... 6
  - 2.2    Thermal data ..... 6
  - 2.3    Electrical characteristics ..... 6
  - 2.4    Electrical characteristics curves ..... 8
  - 2.5    Test and application circuits ..... 10
  
- 3      Package information ..... 12**
  
- 4      Revision history ..... 13**

## List of tables

Table 1.	Device summary . . . . .	1
Table 2.	Absolute maximum ratings . . . . .	6
Table 3.	Thermal data . . . . .	6
Table 4.	Electrical characteristics . . . . .	6
Table 5.	Document revision history . . . . .	13

## List of figures

Figure 1.	Block diagram . . . . .	5
Figure 2.	Pins connection diagram (top view) . . . . .	5
Figure 3.	Clip detector threshold vs. THD set. voltage . . . . .	8
Figure 4.	Quiescent current vs. supply voltage . . . . .	8
Figure 5.	Output power vs. supply voltage (THD = 1 %) . . . . .	8
Figure 6.	Output power vs. supply voltage (THD = 10 %) . . . . .	8
Figure 7.	EIAJ power vs. supply voltage . . . . .	8
Figure 8.	THD vs. frequency . . . . .	8
Figure 9.	THD vs. output power (RL = 4 W) . . . . .	9
Figure 10.	THD vs. output power (RL = 24 W) . . . . .	9
Figure 11.	Dissipated power and efficiency vs. output power . . . . .	9
Figure 12.	SVR vs. frequency . . . . .	9
Figure 13.	CMRR vs. frequency . . . . .	9
Figure 14.	Crosstalk vs. frequency . . . . .	9
Figure 15.	Differential inputs test and application circuit . . . . .	10
Figure 16.	Single ended inputs test and application circuit . . . . .	10
Figure 17.	Application board reference circuit . . . . .	11
Figure 18.	PowerSO36 (slug up) mechanical data and package dimensions . . . . .	12

# 1 Block and pins connection diagrams

Figure 1. Block diagram

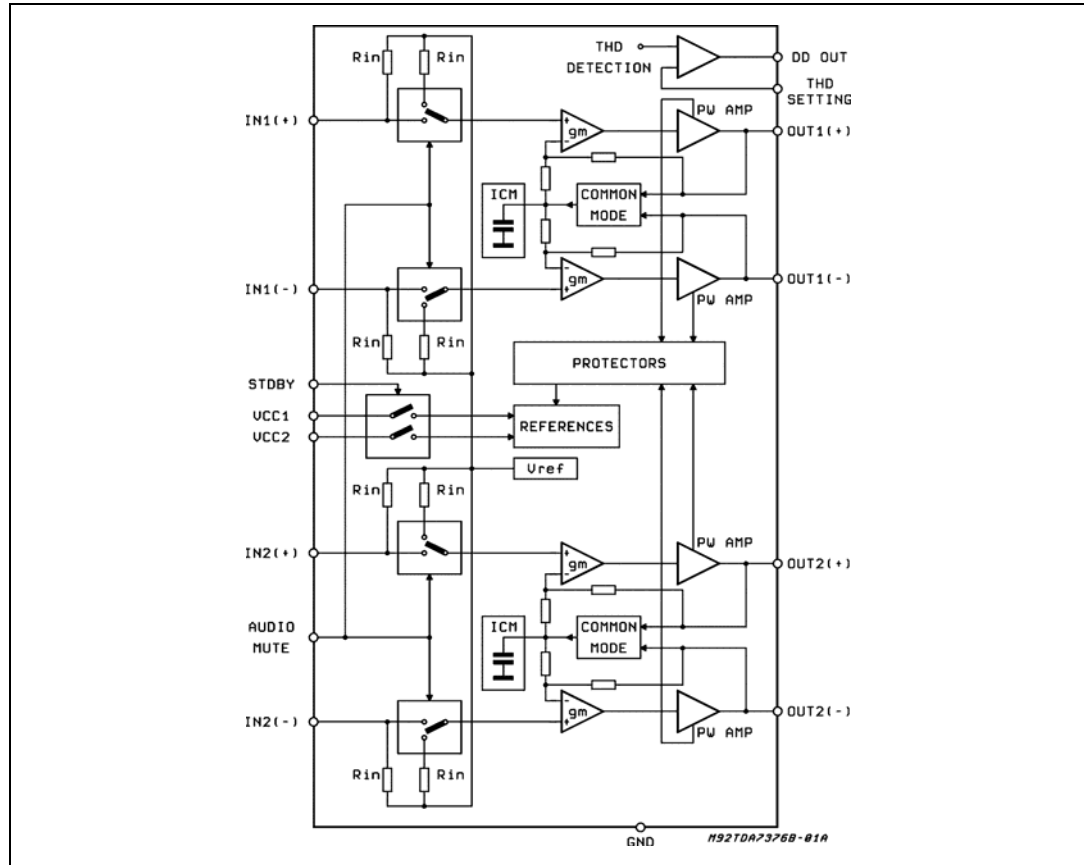
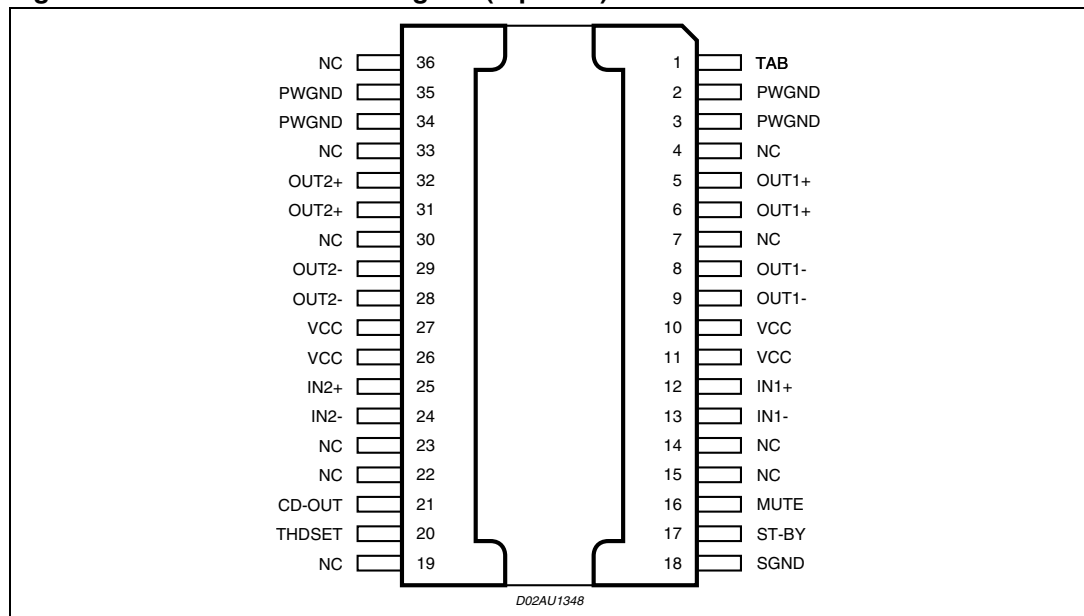

Figure 2. Pins connection diagram (top view)



## 2 Electrical specifications

### 2.1 Absolute maximum ratings

**Table 2. Absolute maximum ratings**

Symbol	Parameter	Value	Unit
$V_{OP}$	Operating supply voltage	18	V
$V_S$	DC supply voltage	28	V
$V_{peak}$	Peak supply voltage (t = 50 ms)	50	V
$I_O$	Output peak current (not repetitive t = 100 $\mu$ s)	8	A
	Output peak current (repetitive f > 10 Hz)	6	A
$P_{tot}$	Power dissipation $T_{case} = 85^\circ\text{C}$	36	W
$T_{stg}, T_j$	Storage and junction temperature	-40 to 150	$^\circ\text{C}$

### 2.2 Thermal data

**Table 3. Thermal data**

Symbol	Parameter	Value	Unit
$R_{th\ j-case}$	Thermal resistance junction-to-case	Max 2	$^\circ\text{C/W}$

### 2.3 Electrical characteristics

Refer to the test circuits [Figure 15](#) and [16](#),  $V_S = 14.4\text{ V}$ ;  $R_L = 4\ \Omega$ ;  $f = 1\text{ kHz}$ ;  $T_{amb} = 25\ ^\circ\text{C}$ , unless otherwise specified.

**Table 4. Electrical characteristics**

Symbol	Parameter	Test condition	Min.	Typ.	Max.	Unit
$V_S$	Supply voltage range	-	8	-	18	V
$I_d$	Total quiescent drain current	$R_L = \infty$	-	-	200	mA
$V_{OS}$	Output offset voltage	-	-	-	120	mV
$P_O$	Output power	THD = 10 %;	23	25	-	W
		THD = 10 %; $R_L = 2\ \Omega$	33	37	-	W
$P_{O\ max}$	Max. output power <sup>(1)</sup>	-	36	40	-	W
$P_{O\ EIAJ}$	EIAJ output power <sup>(1)</sup>	$V_S = 13.7\text{ V}$	32	35	-	W
THD	Distortion	$P_O = 0.5\text{ to }10\text{ W}$ $P_O = 0.5\text{ to }15\text{ W}$	-	0.03 0.08	-	%
$C_T$	Cross talk	f = 1 kHz; $R_g$ f = 10 kHz; $R_g$	-	80 70	-	dB

Table 4. Electrical characteristics (continued)

Symbol	Parameter	Test condition	Min.	Typ.	Max.	Unit
R <sub>IN</sub>	Input impedance	differential input	45	-	-	kΩ
		Single Ended input	40	-	-	
G <sub>V</sub>	Voltage gain	differential input	25	26	27	dB
		Single Ended input	25	26	27	dB
ΔG <sub>V</sub>	Channel gain balance	-	-	-	1	dB
E <sub>IN</sub>	Input noise voltage	R <sub>g</sub> = 600 Ω; "A" weighted R <sub>g</sub> = 600 Ω; 22 Hz to 33 kHz	-	3 4	6	μV
SVR	Supply voltage rejection	f = 100 Hz; V <sub>r</sub> = 1 Vrms; R <sub>g</sub> = 0; f = 10 Hz; V <sub>r</sub> = 1 Vrms; R <sub>g</sub> = 0;	45	55	-	dB
BW	Power bandwidth	(-3dB)	75	-	-	kHz
CMRR	Common mode rejection ratio	V <sub>CM</sub> = 1 Vrms input referred	60	-	-	dB
A <sub>SB</sub>	Standby attenuation	V <sub>SB</sub> = 1.5V; P <sub>O ref</sub> = 1 W	80	90	-	dB
V <sub>SB IN</sub>	Standby input threshold	-	-	-	1.5	V
V <sub>SB OUT</sub>	Standby output threshold	-	3.5	-	-	V
I <sub>sb</sub>	Standby current consumption	V <sub>SB</sub> = 0V	-	-	20	μA
A <sub>M</sub>	Mute attenuation	V <sub>M</sub> = 1.5 V; P <sub>O ref</sub> = 1 W	-	85	-	dB
V <sub>M IN</sub>	Mute in threshold	-	-	-	1.5	V
V <sub>M OUT</sub>	Mute out threshold	-	3.5	-	-	V
I <sub>6</sub>	Mute pin current	V <sub>6</sub> = 0 to V <sub>S</sub> ; V <sub>S max.</sub> = 18 V	-	-	100	μA
D <sub>DL</sub>	Distortion detection level <sup>(2)</sup>	-	3.5	-	-	%
D <sub>DOUT</sub>	Distortion detector output DC current	Output low, sinked current (V <sub>pin10</sub> = 1.5 V)	1	-	-	mA
		Output high, leakage current (V <sub>pin10</sub> = V <sub>S</sub> , @ V <sub>S max.</sub> = 18 V)	-	-	10	μA

1. Saturated square wave output
2. See [Figure 3](#) for THD setting.

The TDA7376PD is equipped with a programmable clipping distortion detector circuitry that allows to signal out the output stage saturation by providing a current sinking into an open collector output (D<sub>DOUT</sub>) when the total harmonic distortion of the output signal reaches the preset level. The desired threshold is fixed through an external divider that produces a proper voltage level across the THD set pin. [Figure 3](#) shows the THD detection threshold versus the THD set voltage. Since it is essential that the THD set voltage be proportional to the supply voltage, [Figure 4](#) shows its value as a fraction of V<sub>CC</sub>. The actual voltage can be computed by multiplying the fraction corresponding to the desired THD threshold by the application's supply voltage.

## 2.4 Electrical characteristics curves

**Figure 3. Clip detector threshold vs. THD set. Figure 4. Quiescent current vs. supply voltage**

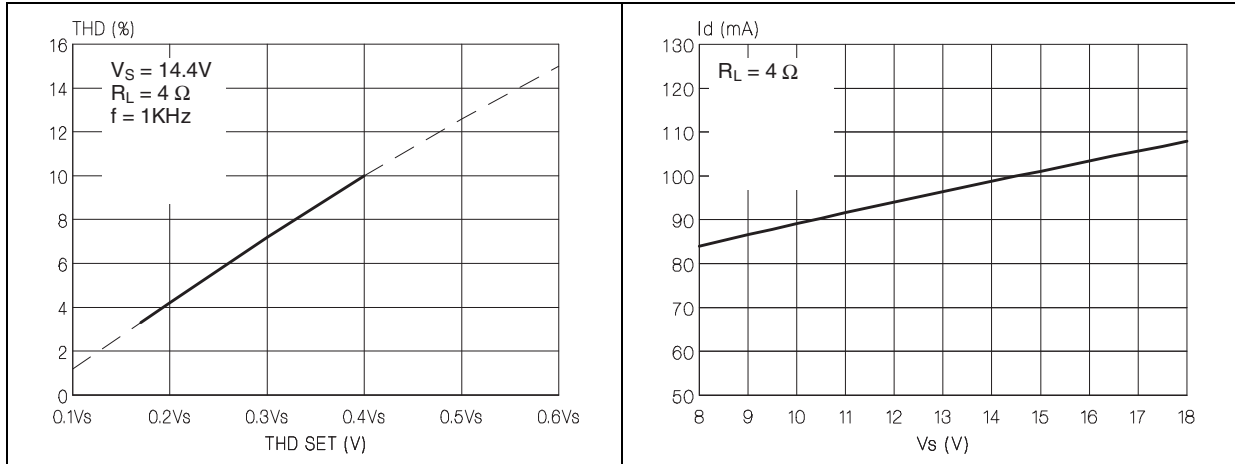

**Figure 5. Output power vs. supply voltage (THD = 1 %)**

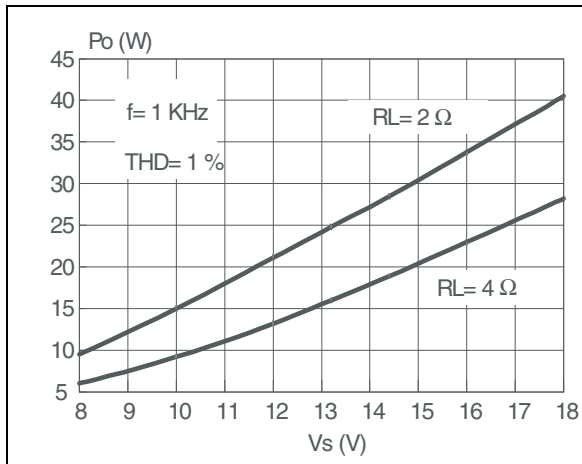

**Figure 7. EIAJ power vs. supply voltage**

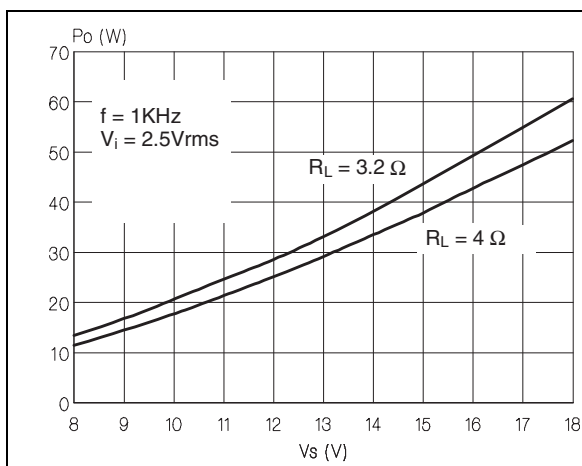

**Figure 6. Output power vs. supply voltage (THD = 10 %)**

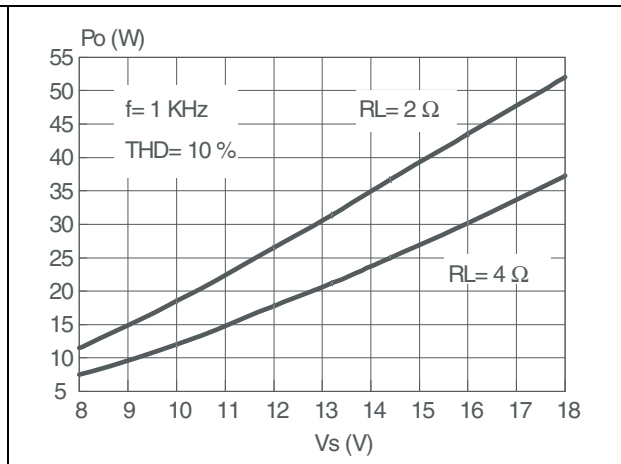

**Figure 8. THD vs. frequency**

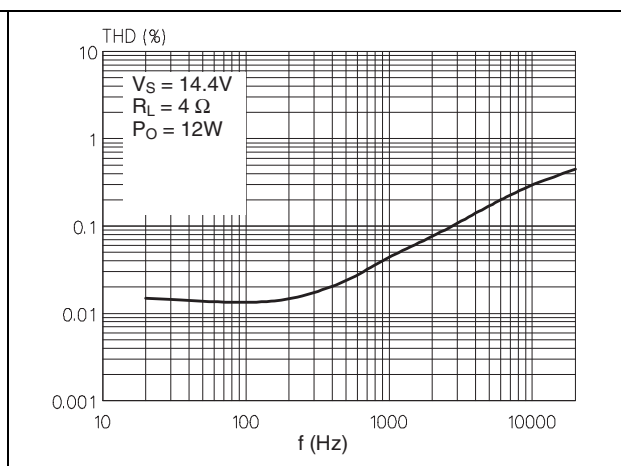



Figure 9. THD vs. output power ( $R_L = 4 \Omega$ )

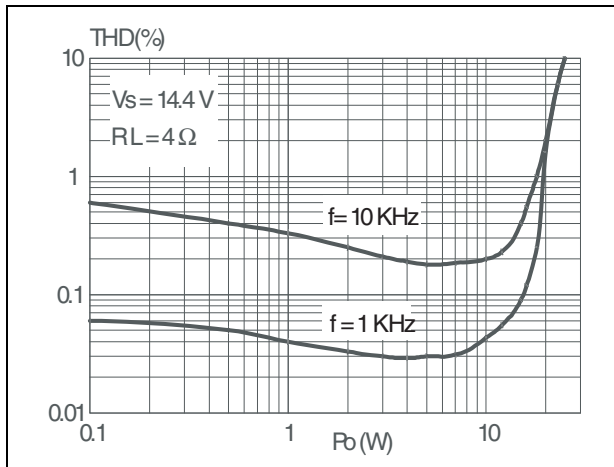

Figure 10. THD vs. output power ( $R_L = 24 \Omega$ )

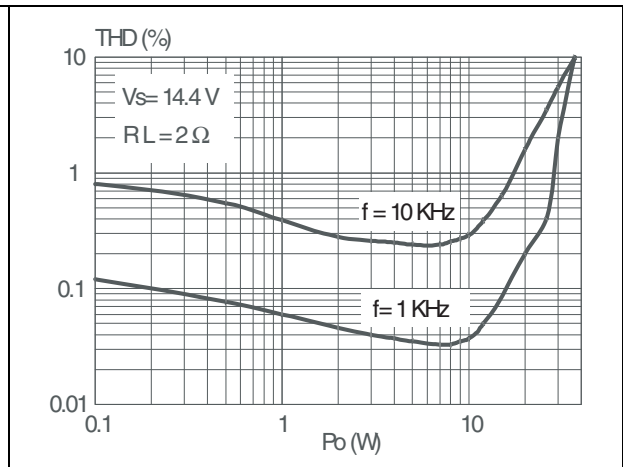

Figure 11. Dissipated power and efficiency vs. output power

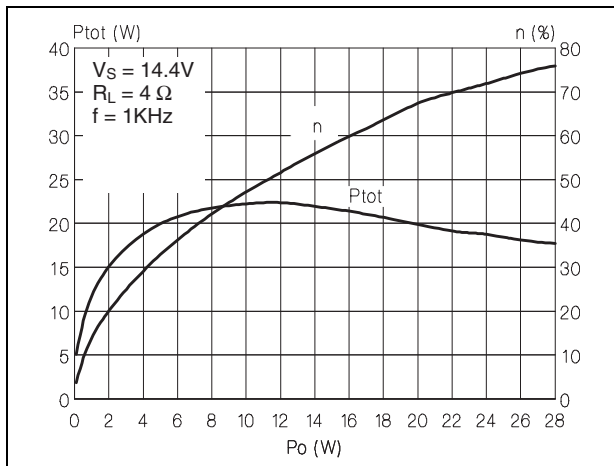

Figure 12. SVR vs. frequency

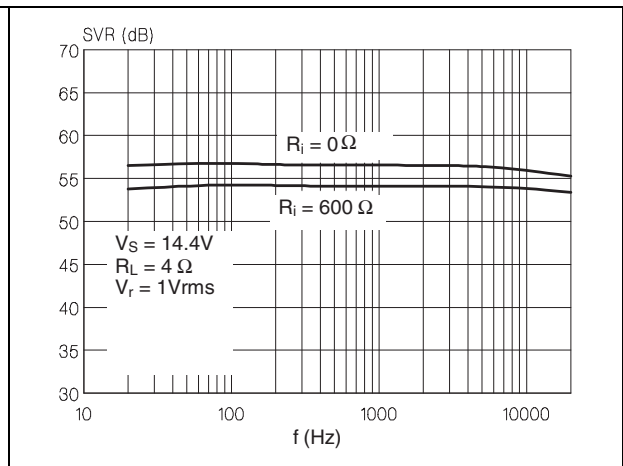

Figure 13. CMRR vs. frequency

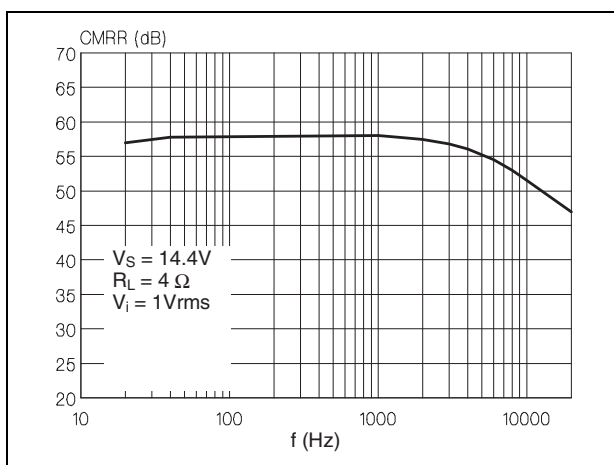
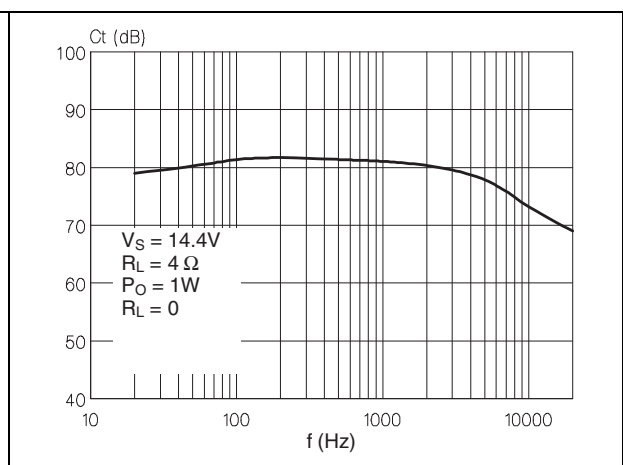

Figure 14. Crosstalk vs. frequency



## 2.5 Test and application circuits

Figure 15. Differential inputs test and application circuit

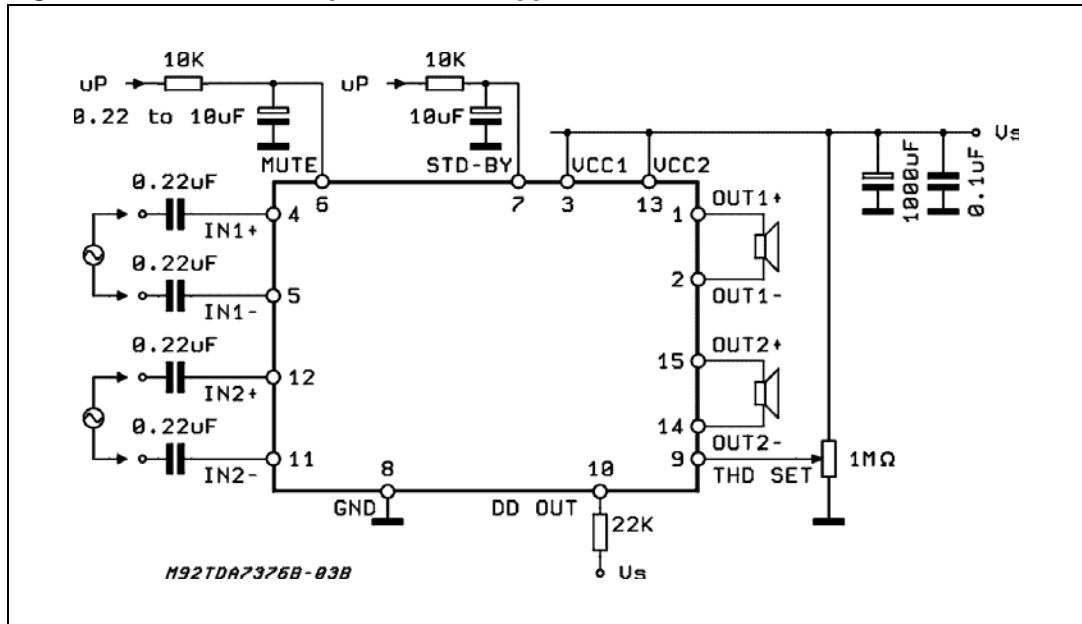

Figure 16. Single ended inputs test and application circuit

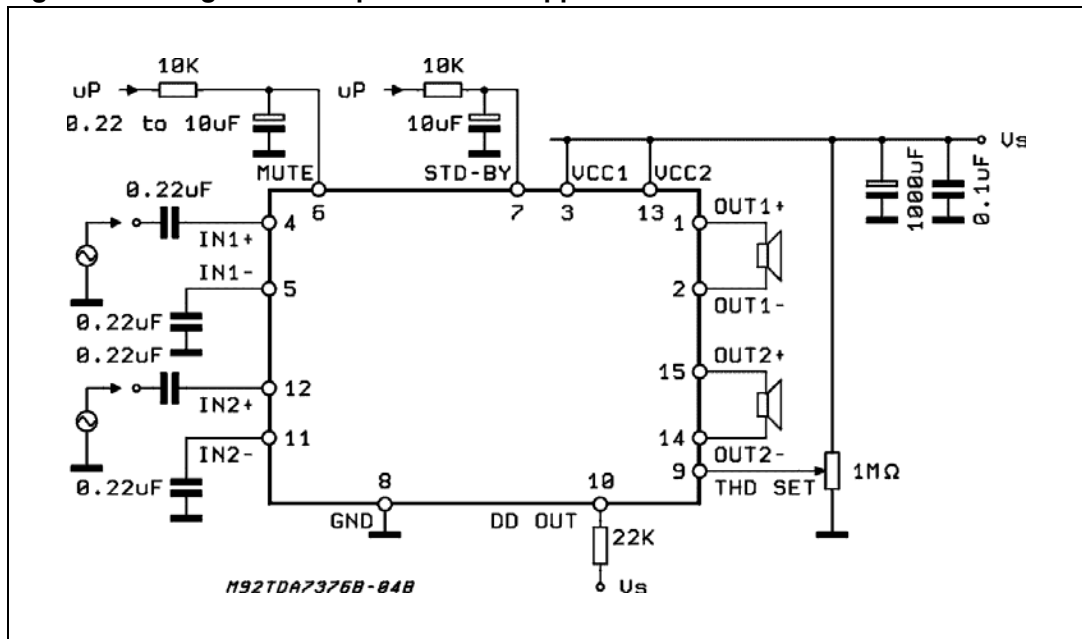
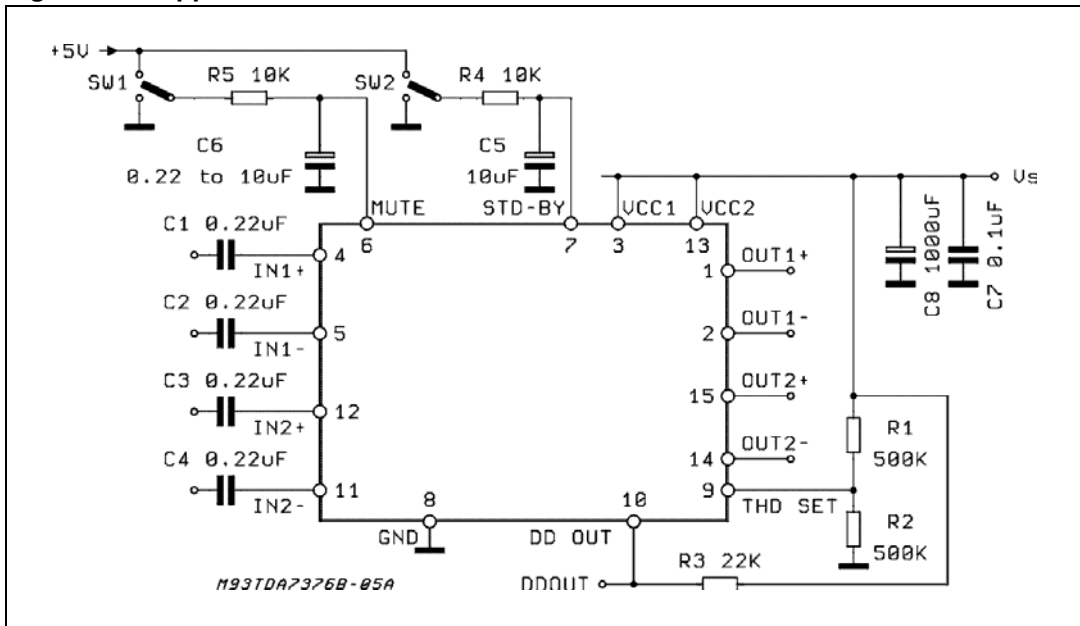

Figure 17. Application board reference circuit



### 3 Package information

In order to meet environmental requirements, ST offers these devices in different grades of ECOPACK® packages, depending on their level of environmental compliance. ECOPACK® specifications, grade definitions and product status are available at: [www.st.com](http://www.st.com).

ECOPACK® is an ST trademark.

**Figure 18. PowerSO36 (slug up) mechanical data and package dimensions**

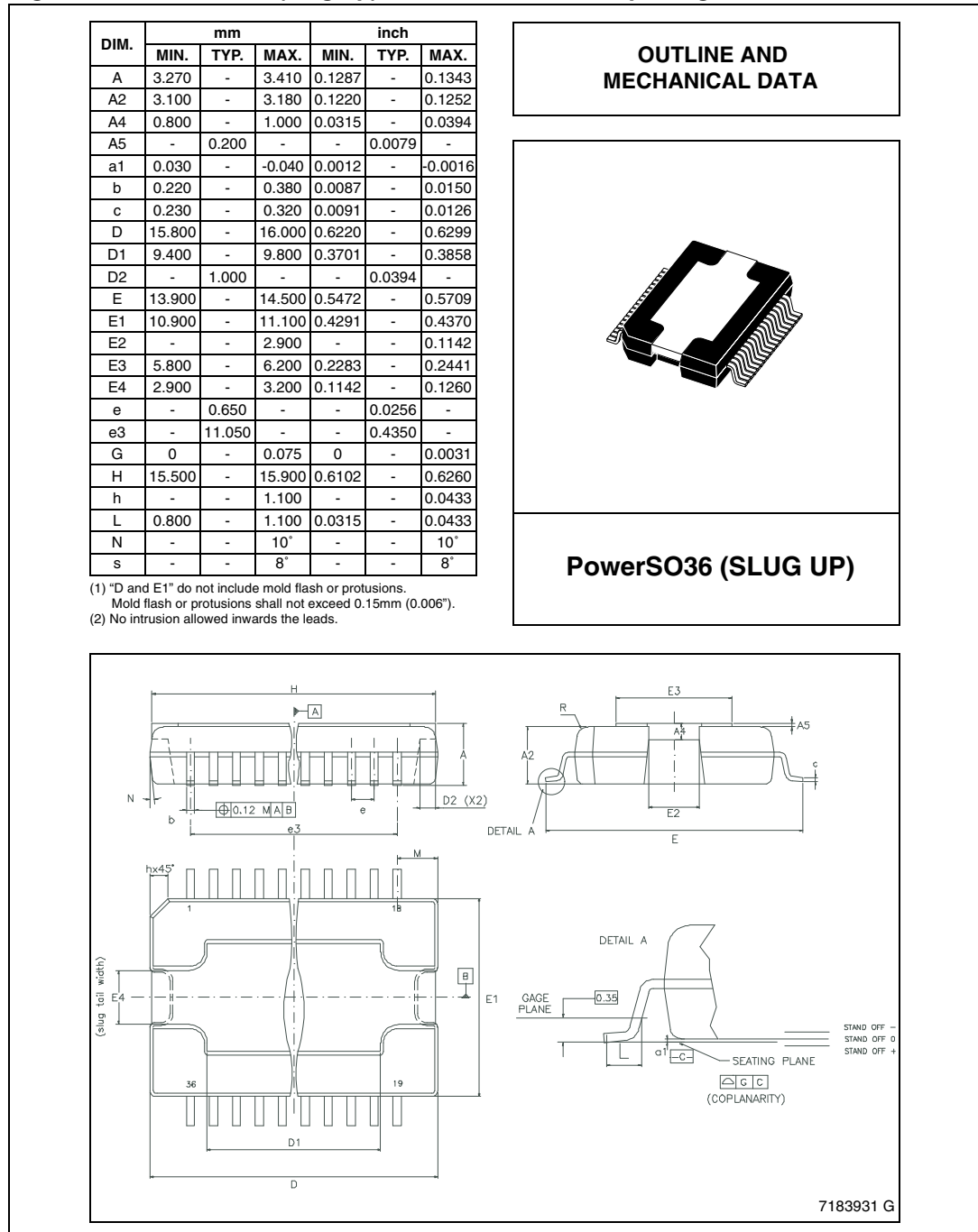

## 4 Revision history

**Table 5. Document revision history**

Date	Revision	Changes
13-Dec-2003	1	Initial release.
16-Apr-2004	2	Corrected package drawing.
11-Dec-2009	3	Document reformatted. Updated <a href="#">Section 3: Package information on page 12.</a>
17-Sep-2013	4	Updated Disclaimer.

**Please Read Carefully:**

Information in this document is provided solely in connection with ST products. STMicroelectronics NV and its subsidiaries ("ST") reserve the right to make changes, corrections, modifications or improvements, to this document, and the products and services described herein at any time, without notice.

All ST products are sold pursuant to ST's terms and conditions of sale.

Purchasers are solely responsible for the choice, selection and use of the ST products and services described herein, and ST assumes no liability whatsoever relating to the choice, selection or use of the ST products and services described herein.

No license, express or implied, by estoppel or otherwise, to any intellectual property rights is granted under this document. If any part of this document refers to any third party products or services it shall not be deemed a license grant by ST for the use of such third party products or services, or any intellectual property contained therein or considered as a warranty covering the use in any manner whatsoever of such third party products or services or any intellectual property contained therein.

**UNLESS OTHERWISE SET FORTH IN ST'S TERMS AND CONDITIONS OF SALE ST DISCLAIMS ANY EXPRESS OR IMPLIED WARRANTY WITH RESPECT TO THE USE AND/OR SALE OF ST PRODUCTS INCLUDING WITHOUT LIMITATION IMPLIED WARRANTIES OF MERCHANTABILITY, FITNESS FOR A PARTICULAR PURPOSE (AND THEIR EQUIVALENTS UNDER THE LAWS OF ANY JURISDICTION), OR INFRINGEMENT OF ANY PATENT, COPYRIGHT OR OTHER INTELLECTUAL PROPERTY RIGHT.**

**ST PRODUCTS ARE NOT DESIGNED OR AUTHORIZED FOR USE IN: (A) SAFETY CRITICAL APPLICATIONS SUCH AS LIFE SUPPORTING, ACTIVE IMPLANTED DEVICES OR SYSTEMS WITH PRODUCT FUNCTIONAL SAFETY REQUIREMENTS; (B) AERONAUTIC APPLICATIONS; (C) AUTOMOTIVE APPLICATIONS OR ENVIRONMENTS, AND/OR (D) AEROSPACE APPLICATIONS OR ENVIRONMENTS. WHERE ST PRODUCTS ARE NOT DESIGNED FOR SUCH USE, THE PURCHASER SHALL USE PRODUCTS AT PURCHASER'S SOLE RISK, EVEN IF ST HAS BEEN INFORMED IN WRITING OF SUCH USAGE, UNLESS A PRODUCT IS EXPRESSLY DESIGNATED BY ST AS BEING INTENDED FOR "AUTOMOTIVE, AUTOMOTIVE SAFETY OR MEDICAL" INDUSTRY DOMAINS ACCORDING TO ST PRODUCT DESIGN SPECIFICATIONS. PRODUCTS FORMALLY ESCC, QML OR JAN QUALIFIED ARE DEEMED SUITABLE FOR USE IN AEROSPACE BY THE CORRESPONDING GOVERNMENTAL AGENCY.**

Resale of ST products with provisions different from the statements and/or technical features set forth in this document shall immediately void any warranty granted by ST for the ST product or service described herein and shall not create or extend in any manner whatsoever, any liability of ST.

ST and the ST logo are trademarks or registered trademarks of ST in various countries.

Information in this document supersedes and replaces all information previously supplied.

The ST logo is a registered trademark of STMicroelectronics. All other names are the property of their respective owners.

© 2013 STMicroelectronics - All rights reserved

STMicroelectronics group of companies

Australia - Belgium - Brazil - Canada - China - Czech Republic - Finland - France - Germany - Hong Kong - India - Israel - Italy - Japan - Malaysia - Malta - Morocco - Philippines - Singapore - Spain - Sweden - Switzerland - United Kingdom - United States of America

[www.st.com](http://www.st.com)



Компания «ЭлектроПласт» предлагает заключение долгосрочных отношений при поставках импортных электронных компонентов на взаимовыгодных условиях!

Наши преимущества:

- Оперативные поставки широкого спектра электронных компонентов отечественного и импортного производства напрямую от производителей и с крупнейших мировых складов;
- Поставка более 17-ти миллионов наименований электронных компонентов;
- Поставка сложных, дефицитных, либо снятых с производства позиций;
- Оперативные сроки поставки под заказ (от 5 рабочих дней);
- Экспресс доставка в любую точку России;
- Техническая поддержка проекта, помощь в подборе аналогов, поставка прототипов;
- Система менеджмента качества сертифицирована по Международному стандарту ISO 9001;
- Лицензия ФСБ на осуществление работ с использованием сведений, составляющих государственную тайну;
- Поставка специализированных компонентов (Xilinx, Altera, Analog Devices, Intersil, Interpoint, Microsemi, Aeroflex, Peregrine, Syfer, Eurofarad, Texas Instrument, Miteq, Cobham, E2V, MA-COM, Hittite, Mini-Circuits, General Dynamics и др.);

Помимо этого, одним из направлений компании «ЭлектроПласт» является направление «Источники питания». Мы предлагаем Вам помощь Конструкторского отдела:

- Подбор оптимального решения, техническое обоснование при выборе компонента;
- Подбор аналогов;
- Консультации по применению компонента;
- Поставка образцов и прототипов;
- Техническая поддержка проекта;
- Защита от снятия компонента с производства.



#### Как с нами связаться

**Телефон:** 8 (812) 309 58 32 (многоканальный)

**Факс:** 8 (812) 320-02-42

**Электронная почта:** [org@eplast1.ru](mailto:org@eplast1.ru)

**Адрес:** 198099, г. Санкт-Петербург, ул. Калинина, дом 2, корпус 4, литера А.