

Bolt Style EMI Filters

SA Series – 4-40 Thread - Epoxy Sealed – Circuits Available – C & L

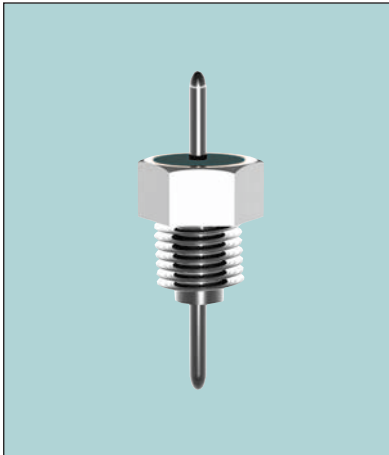

APPLICATIONS

The SA series provides effective filtering in the RF and MICROWAVE frequency spectrums from 10 MHz through 26 GHz. Designed for mounting in a tapped bulkhead or with the standard nut and lockwasher provided, it is ideal for high impedance circuits where large capacitance values are not practical. In the “L” section version an internal ferrite bead

element provides both inductance and series resistance (lossy characteristic) which improves insertion loss and provides superior transient performance. The SA series comes with a standard .020 diameter beryllium copper lead. Alternate lead lengths, diameters of .016 or .026 and alternate materials in steel or half-hard copper are available.

CHARACTERISTICS

- Meets or exceeds the applicable portions of MIL-F-28861/6. See QPL listings.
- Smallest screwbody filter available.
- Features rugged monolithic discoidal capacitor construction.
- Epoxy seal on both ends.

SPECIFICATIONS

1. Plating: Silver standard – Electro-tin or gold available
2. Material:
 - Case: Cold rolled steel
 - Leads: Beryllium copper (steel or half/hard copper leads available)
3. Operating Temperature Range: -55°C to +125°C
4. Insulation Resistance:
 - At 25°C: 1,000 megohm-microfarad min., or 100,000 megohms min., whichever is less
 - At 125°C: 100 megohm-microfarad min., or 10,000 megohms min., whichever is less
5. Dielectric Withstanding Voltage (DWW):
 - R-level designs: 2.0 times rated DC voltage
 - Class B, Class S designs: 2.5 times rated DC voltage
6. DC Resistance (DCR): .02 ohm, maximum
7. Dissipation Factor (DF): 3% maximum
8. Rated DC Current: 5 Amps, maximum
9. Recommended Mounting Torque: 32 oz-in. ± 4 oz-in.
10. Supplied with mounting nut and lockwasher - See Filter Design Guide Screw and Locking Washer Table
11. Insertion Loss for the “C” and “L” sections are equivalent due to the saturation characteristic of the ferrite bead element at rated current. At lower currents the “L” becomes much more effective.

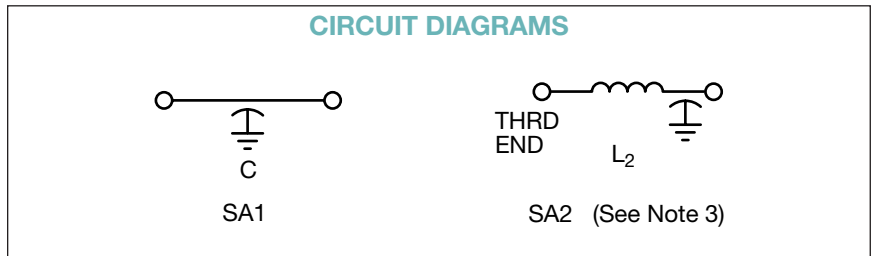
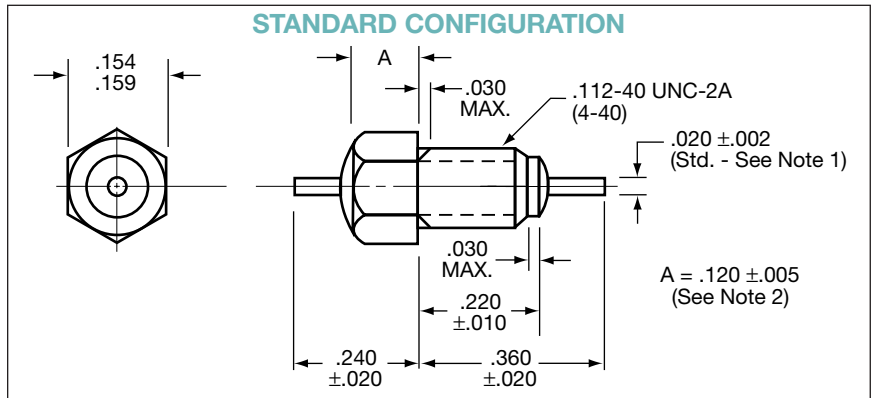

millimeters (inches)	
0.05 (.002)	3.05 (.120)
0.13 (.005)	3.68 (.145)
0.25 (.010)	3.91 (.154)
0.41 (.016)	4.04 (.159)
0.51 (.020)	5.59 (.220)
0.66 (.026)	6.10 (.240)
0.76 (.030)	9.14 (.360)
2.84 (.112)	—

(See Note 4)

Notes:

1. Standard catalog designs have .020" dia. lead. MIL-F-28861/6 calls for .026" dia. .026" dia. will not be supplied unless specified.
2. "A" dimension of .120 ± .005 will satisfy M28861/6-003 requirement for .145 ± .030. All "SA" series are supplied A = .120 ± .005.
3. All SA2 L-Section Filters have inductor (bead) at threaded end.
4. Metric equivalent dimensions given for information only.

Bolt Style EMI Filters

SA Series – 4-40 Thread - Epoxy Sealed – Circuits Available – C & L



SPECIFICATIONS

AVX P/N	CKT	CAP ¹	DC Voltage	DCR	Insertion Loss ² Per MIL-STD-220, +25°C					
					1 MHz	10 MHz	100 MHz	200 MHz	1 GHz	10 GHz
SA1C1-102	C	1000	50	.02	–	4	20	25	25	55
SA1C1-502	C	5000	50	.02	–	15	34	41	42	55
SA1C1-103	C	.01	50	.02	4	21	35	42	50	70
SA1C1-273	C	.027	50	.02	10	30	39	43	65	70
SA1C1-503	C	.05	50	.02	15	35	42	45	70	70
SA2C1-102	L2	1000	50	.02	–	4	20	27	30	60
SA2C1-502	L2	5000	50	.02	–	15	35	41	45	60
SA2C1-103	L2	.01	50	.02	4	21	35	44	50	70
SA2C1-273	L2	.027	50	.02	10	30	50	45	65	70
SA2C1-503	L2	.05	50	.02	15	37	45	45	70	70
SA1A1-102	C	1000	100	.02	–	4	20	25	25	55
SA1A1-502	C	5000	100	.02	–	15	35	41	42	55
SA1A1-103	C	.01	100	.02	4	21	35	42	50	70
SA1A1-273	C	.027	100	.02	10	30	39	43	65	70
SA1A1-453	C	.045	100	.02	14	35	42	45	70	70
SA2A1-102	L2	1000	100	.02	–	4	20	27	30	60
SA2A1-502	L2	5000	100	.02	–	15	35	41	45	60
SA2A1-103	L2	.01	100	.02	4	21	35	44	50	70
SA2A1-273	L2	.027	100	.02	10	30	50	45	70	70
SA2A1-453	L2	.045	100	.02	14	37	45	45	70	70
SA1B1-102	C	1000	200	.02	–	4	20	25	25	55
SA1B1-502	C	5000	200	.02	–	15	34	41	42	55
SA1B1-103	C	.01	200	.02	4	21	35	42	50	70
SA2B1-102	L2	1000	200	.02	–	4	20	27	30	60
SA2B1-502	L2	5000	200	.02	–	15	35	41	45	60
SA2B1-103	L2	.01	200	.02	4	21	35	44	50	70

¹ Decimal point values indicate capacitance in microfarads.
Non-decimal point values indicate capacitance in picofarads.

² Insertion loss limits are based on theoretical values.
Actual measurements may vary due to internal capacitor
resonances and other design constraints.



Компания «ЭлектроПласт» предлагает заключение долгосрочных отношений при поставках импортных электронных компонентов на взаимовыгодных условиях!

Наши преимущества:

- Оперативные поставки широкого спектра электронных компонентов отечественного и импортного производства напрямую от производителей и с крупнейших мировых складов;
- Поставка более 17-ти миллионов наименований электронных компонентов;
- Поставка сложных, дефицитных, либо снятых с производства позиций;
- Оперативные сроки поставки под заказ (от 5 рабочих дней);
- Экспресс доставка в любую точку России;
- Техническая поддержка проекта, помощь в подборе аналогов, поставка прототипов;
- Система менеджмента качества сертифицирована по Международному стандарту ISO 9001;
- Лицензия ФСБ на осуществление работ с использованием сведений, составляющих государственную тайну;
- Поставка специализированных компонентов (Xilinx, Altera, Analog Devices, Intersil, Interpoint, Microsemi, Aeroflex, Peregrine, Syfer, Eurofarad, Texas Instrument, Miteq, Cobham, E2V, MA-COM, Hittite, Mini-Circuits, General Dynamics и др.);

Помимо этого, одним из направлений компании «ЭлектроПласт» является направление «Источники питания». Мы предлагаем Вам помощь Конструкторского отдела:

- Подбор оптимального решения, техническое обоснование при выборе компонента;
- Подбор аналогов;
- Консультации по применению компонента;
- Поставка образцов и прототипов;
- Техническая поддержка проекта;
- Защита от снятия компонента с производства.



Как с нами связаться

Телефон: 8 (812) 309 58 32 (многоканальный)

Факс: 8 (812) 320-02-42

Электронная почта: org@eplast1.ru

Адрес: 198099, г. Санкт-Петербург, ул. Калинина, дом 2, корпус 4, литера А.