

FLUKE®

CLKT, CLKTO, CLV Infrared Window Installation Guide

Introduction

The Infrared Window is a precision made accessory which, when accurately installed, will give years of trouble free service. Read and understand these instructions thoroughly before attempting to install the units.

All of the items in Table 1 are available from Fluke.

Table 1.

Model	Application	Type	Size
CLKT	Outdoor	3, 12	2", 3", 4"
CLKTO, CLV	Indoor	1	3"

PN 3783652
June 2010 Rev.1, 3/11
© 2010-11 Fluke Corporation. Product specifications are subject to change without notice. All rights reserved. Printed in UK.

How to Contact Fluke

To contact Fluke, call one of the following telephone numbers:

- Technical Support USA: 1-800-44-FLUKE (1-800-443-5853)
- Calibration/Repair USA: 1-888-99-FLUKE (1-888-993-5853)
- Canada: 1-800-36-FLUKE (1-800-363-5853)
- Europe: +31 402-675-200
- Japan: +81-3-3434-0181
- Singapore: +65-738-5655
- Anywhere in the world: +1-425-446-5500

Or, visit Fluke's website at <http://www.fluke.com/irwindows>.

To view, print, or download the latest manual supplement, visit <http://us.fluke.com/usen/support/manuals>.

Safety Information



Warning

To prevent damage or injury:

- Follow these instructions.
- Comply with local and national safety requirements when working in hazardous locations.
- Wear appropriate eye and ear protection.

Before You Start

The installation may be carried out by using either an electro-hydraulic hole punch (Figure 1, Item 1) or a circular hole saw (Figure 2, Item 1).

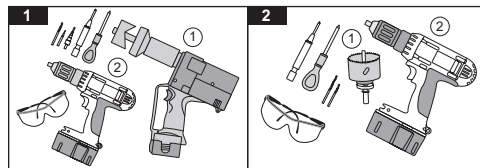

Tools required:

1. Electro-hydraulic punch (Figure 1) or hole saw (Figure 2)
2. Drilling machine
3. Conedrill
4. Pozidrive screwdriver
5. Center punch
6. 6 mm (1/4") high-speed twist drill
7. Tapping drill:
 - for 50 mm (2") units use 2.78 mm (7/64")
 - for 75 mm (3") units use 3.57 mm (9/64")
 - for 100 mm (4") units use 3.57 mm (9/64")
8. Digital vernier calipers.

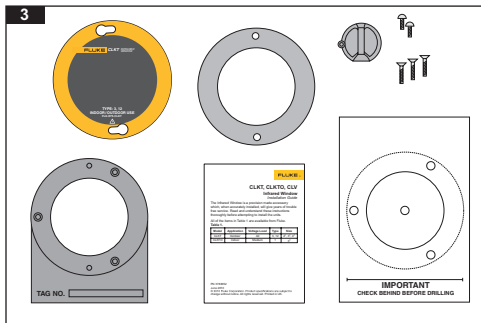

Getting Started

Step 1: Unpack and Check

When your Infrared Window arrives, carefully unpack the unit.

Remove the two front security screws and lay out the components. Check that you have all of the parts (Figure 3).

1. Security screws (2)
2. Security cover (1)
3. 2-hole gasket (1)
4. Fixing screws (various)
5. Drilling template (1)

6. Installation instructions (1)

7. Mounting frame (1)

Step 2: Fit the Drilling Template onto a Flat Surface

Having decided on the correct position for the unit, select the drilling template. Peel off the back and stick to the panel with the wording horizontal (Figure 4).

Step 3: Center Punch

Using the center punch, punch the fixing holes and center hole as marked (Figure 5).

Step 4: Drill Center Hole

Using the 6 mm (1/4") twist drill, drill out the center hole (B) (Figure 6).

- For 50 mm (2") unit, proceed to step 5.
- For 75 mm (3") and 100 mm (4") units, proceed to step 6.

Step 5: Drill Fixing Holes

Using the 2.78 mm (7/64") twist drill, drill out the fixing holes (Figure 7).

- If using hole saws, proceed to step 7(A).
- If using the hole punch, proceed to step 8(A).

Step 6: Drill Fixing Holes

Using the 3.57 mm (9/64") twist drill, drill out the fixing holes (Figure 8).

- If using hole saws, proceed to step 7(A).
- If using the hole punch, proceed to step 8(A).

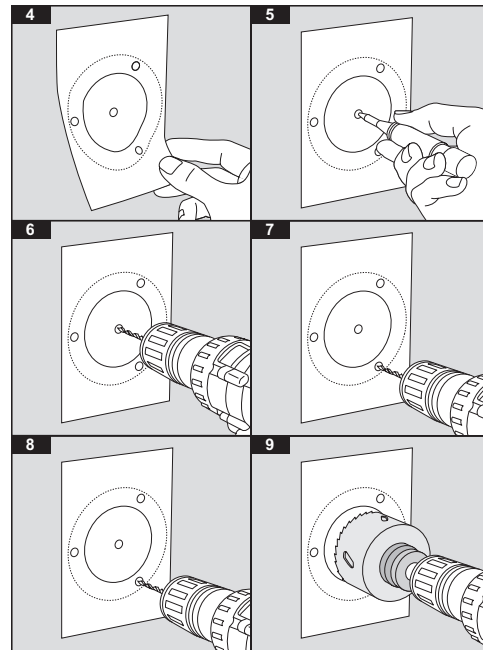

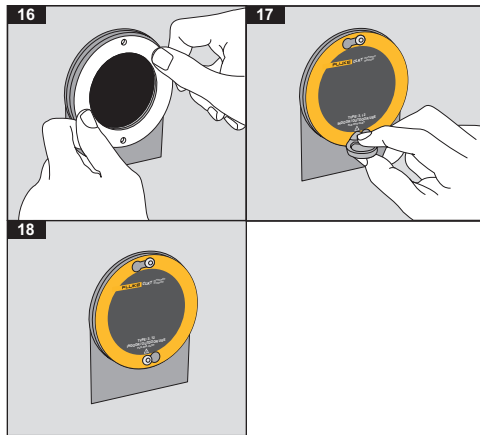
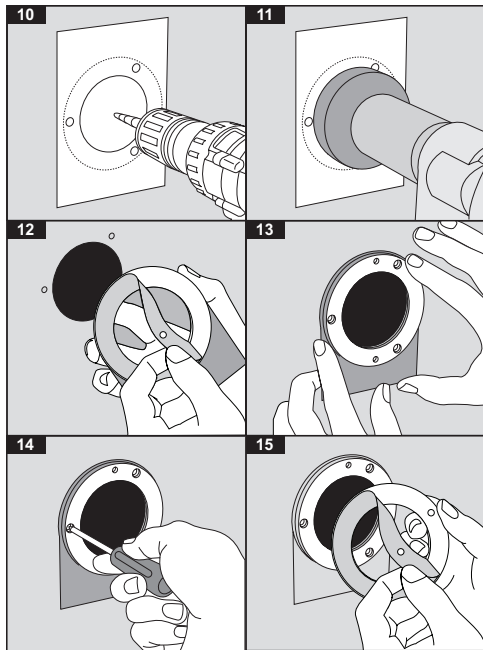

Step 7(A): Enlarging the Center Hole (Hole Saw)

From Table 2, select the correct size of hole saw. Proceed to step 7(B).

Table 2.

Infrared Window Size	Hole Saw Size
50 mm (2")	43 mm (1-3/4")
75 mm (3")	68 mm (2-5/8")
100 mm (4")	93 mm (3-5/8")

Step 7(B): Enlarging the Center Hole (Hole Saw)

Using the 6 mm (1/4") hole as a pilot hole, enlarge the center hole using the selected hole saw (Figure 9). Deburr all of the holes and treat as required. Proceed to step 9.

Step 8(A): Enlarging the Center Hole (Hole Punch)

Refer to the hole punch manual and follow all safety procedures.

From Table 3, select the correct drawbar/punch/die/kwik stepper combination.

Using the Kwik Stepper, enlarge the 6mm center hole (Figure 10) to the size shown in Table 3. Proceed to step 8(B).

Table 3.

Infrared Window Size	Size	K/Step	Greenlee Punch/Die/PN
50 mm (2")	43.2 mm/1.7"	20 mm/0.8"	06974/04013
75 mm (3")	69.9 mm/2.75"	20 mm/0.8"	04247/04246
100 mm (4")	92 mm/3.62"	20 mm/0.8"	Hole Saw Only

Step 8(B): Enlarging the Center Hole (Hole Punch)

Referring to Table 3, and following the instructions in the hole punch manual, punch out the center hole (Figure 11).

Step 9: De-Burr the Holes, Remove any Shavings and the Self Adhesive Template

Degrease the front panel.

Step 10: Fix Infrared Window

Peel off the protective cover from the rear panel gasket on the Infrared Window's mounting frame (Figure 12).

Align the fixing holes and firmly press the Infrared Window into place (Figure 13).

Using the correct sized screwdriver and the countersunk screws provided, fix back the Infrared Window (Figure 14).

Gradually advance each fixing until the gasket is seen to compress evenly. Refer to Table 4.

Step 11 - Fitting Security Cover

Peel off the cover from the 2-hole gasket (Figure 15).

Align the gasket with the two fixing holes positioned vertically and press the gasket into position (Figure 16).

Fit the security cover using the two security screws provided (Figure 17).

The Infrared Window is ready to use. Remember to remove the cover before imaging (Figure 18).

Gasket Compression Table

Tighten tapite screws until gasket compresses as listed in Table 4.

Note

Take all measurements with digital vernier calipers.

Table 4.

2" Compression Table			
Standard Gasket		Premier Gasket	
U/C	C	U/C	C
16.8 mm	16.3 mm	16.3 mm	15.0 mm
0.663"	0.643"	0.643"	0.591"
3" Compression Table			
16.8 mm	16.3 mm	16.3 mm	15.0 mm
0.663"	0.643"	0.643"	0.591"
4" Compression Table			
20.4 mm	19.9 mm	N/A	N/A
0.805"	0.784"	N/A	N/A
U/C = Overall dimension - Exterior of security cover to front face of the panel with gasket uncompressed.			
C = Overall dimension - Exterior of security cover to front face of the panel with gasket compressed.			



Компания «ЭлектроПласт» предлагает заключение долгосрочных отношений при поставках импортных электронных компонентов на взаимовыгодных условиях!

Наши преимущества:

- Оперативные поставки широкого спектра электронных компонентов отечественного и импортного производства напрямую от производителей и с крупнейших мировых складов;
- Поставка более 17-ти миллионов наименований электронных компонентов;
- Поставка сложных, дефицитных, либо снятых с производства позиций;
- Оперативные сроки поставки под заказ (от 5 рабочих дней);
- Экспресс доставка в любую точку России;
- Техническая поддержка проекта, помощь в подборе аналогов, поставка прототипов;
- Система менеджмента качества сертифицирована по Международному стандарту ISO 9001;
- Лицензия ФСБ на осуществление работ с использованием сведений, составляющих государственную тайну;
- Поставка специализированных компонентов (Xilinx, Altera, Analog Devices, Intersil, Interpoint, Microsemi, Aeroflex, Peregrine, Syfer, Eurofarad, Texas Instrument, Miteq, Cobham, E2V, MA-COM, Hittite, Mini-Circuits, General Dynamics и др.);

Помимо этого, одним из направлений компании «ЭлектроПласт» является направление «Источники питания». Мы предлагаем Вам помощь Конструкторского отдела:

- Подбор оптимального решения, техническое обоснование при выборе компонента;
- Подбор аналогов;
- Консультации по применению компонента;
- Поставка образцов и прототипов;
- Техническая поддержка проекта;
- Защита от снятия компонента с производства.



Как с нами связаться

Телефон: 8 (812) 309 58 32 (многоканальный)

Факс: 8 (812) 320-02-42

Электронная почта: org@eplast1.ru

Адрес: 198099, г. Санкт-Петербург, ул. Калинина, дом 2, корпус 4, литера А.