

PRODUCT NUMBER
SEE TABLE

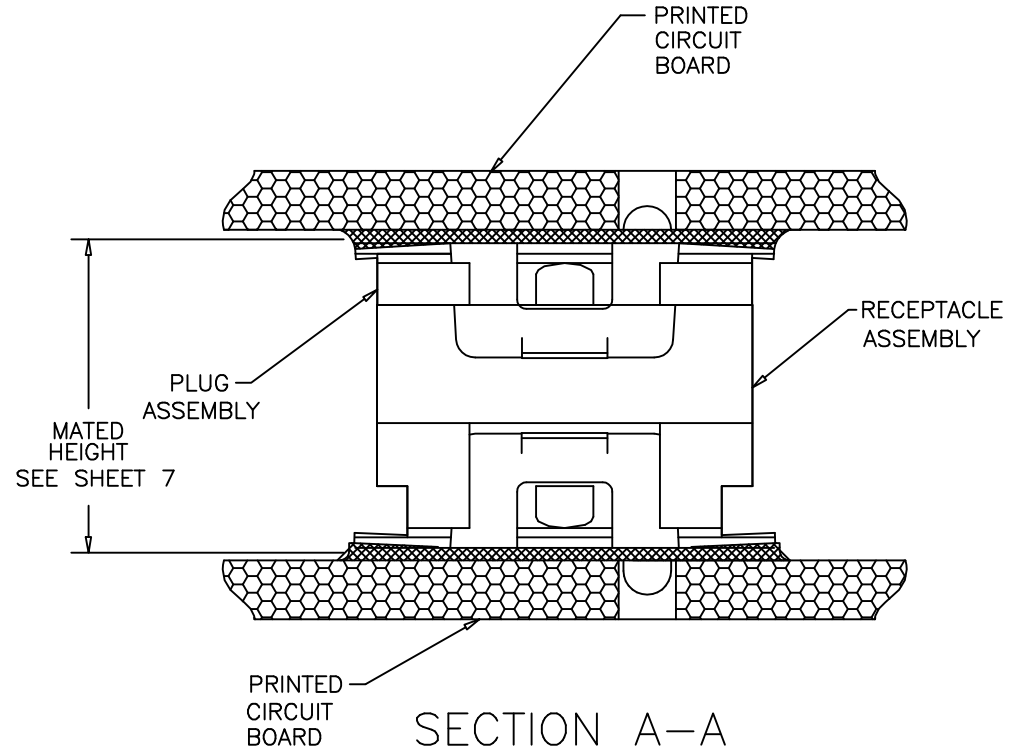

SECTION A-A
ROTATED 90°
N.T.S.

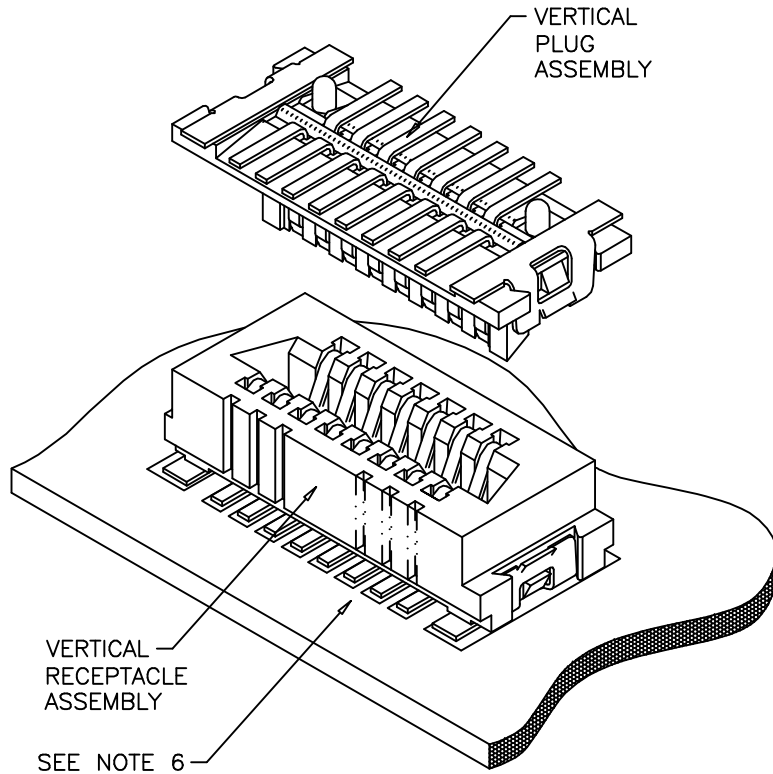

Copyright FCI

mat'l. code		surface ISO 1302		tolerance ISO 406 ISO 1101		projection 		product family CONAN [®]	
ltr	ecn no	dr	date	tolerances unless otherwise specified		INCH/MM 		title CONAN [®] CONNECTOR ASSEMBLY	
A	-	GM	2013-01-14	angles	linear	.XX±.01/.XX±0.3		dwg no	
B	ELX-N-13992	GM	2013-02-05			.XXX±.005/.XX±0.13		sheet 1 of 7	
C	ELX-N-14209	GM	2013-03-07	0°±2'		.XXXX±.0020/.XXX±0.05		size 10124017	
-	-	-	-	dr	GM SUN	2013-01-14		A3	
-	-	-	-	enr	GM SUN	2013-01-14		type Product Customer Drawing	
-	-	-	-	chr	RICK BIAN	2013-01-14			
-	-	-	-	appd	RICK BIAN	2013-01-14			
sheet	revision	C	C	C	C	C	C		
index	sheet	1	2	3	4	5	6	7	

PRODUCT NUMBER
SEE TABLE

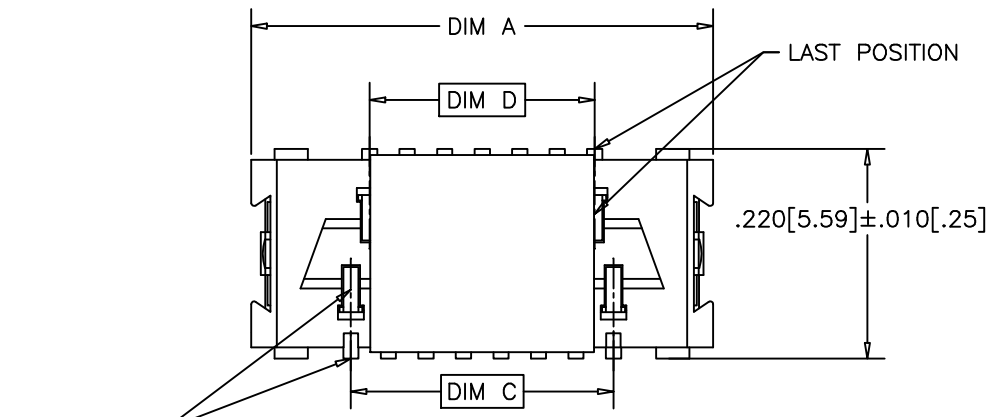

RECEPTACLE

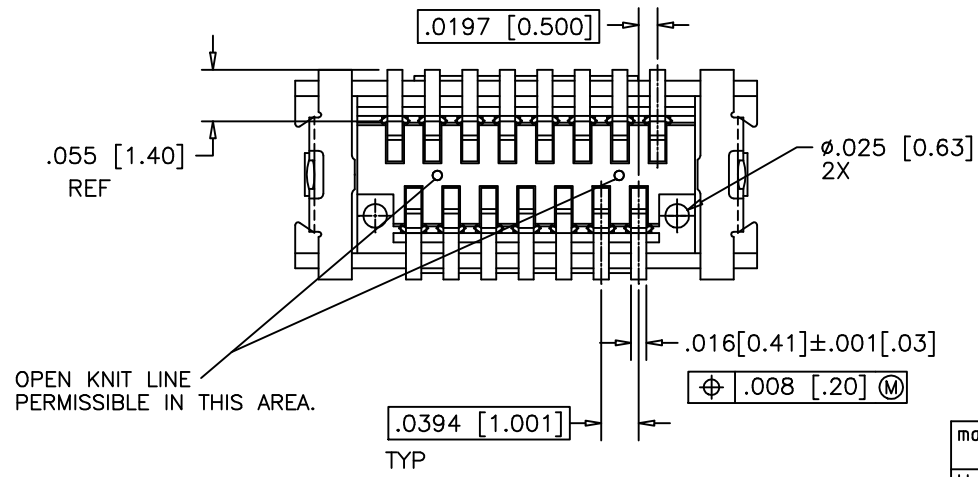
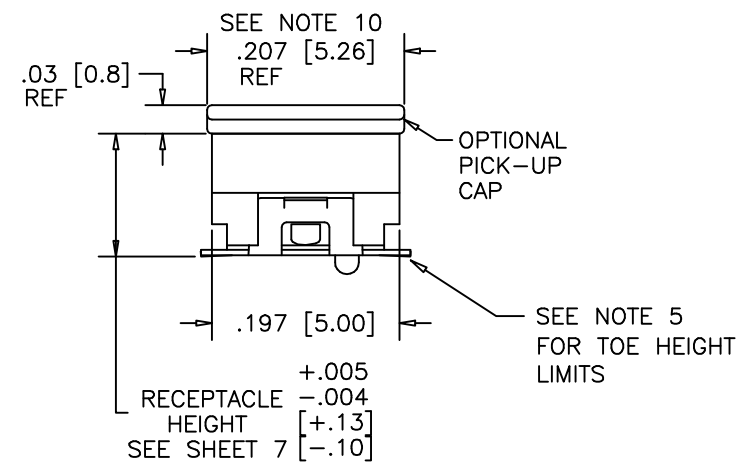
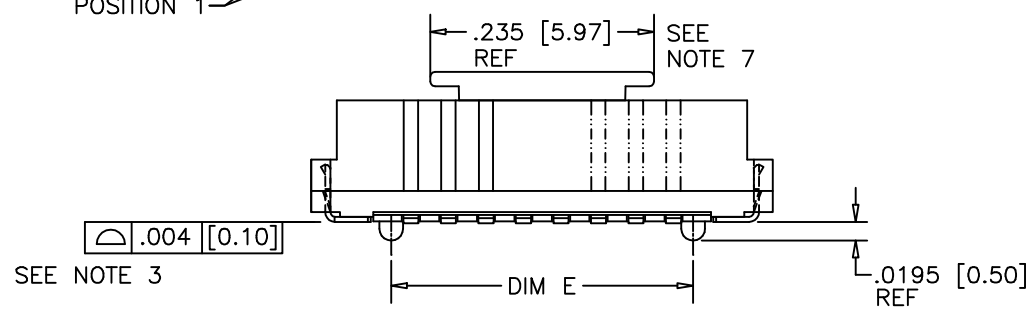

mat'l. code		surface ISO 1302 ✓	tolerance ISO 406 ISO 1101	projection INCH/MM scale 5:1	product family CONAN®
ltr	ecn no	dr	date	title CONAN® CONNECTOR ASSEMBLY	
c				dwg no 10124017	
				sheet 2of 7 size A3	
				type Product Customer Drawing	
sheet index	revision sheet				



Copyright FCI

1

2 3

4

5

6

PRODUCT NUMBER
SEE TABLE

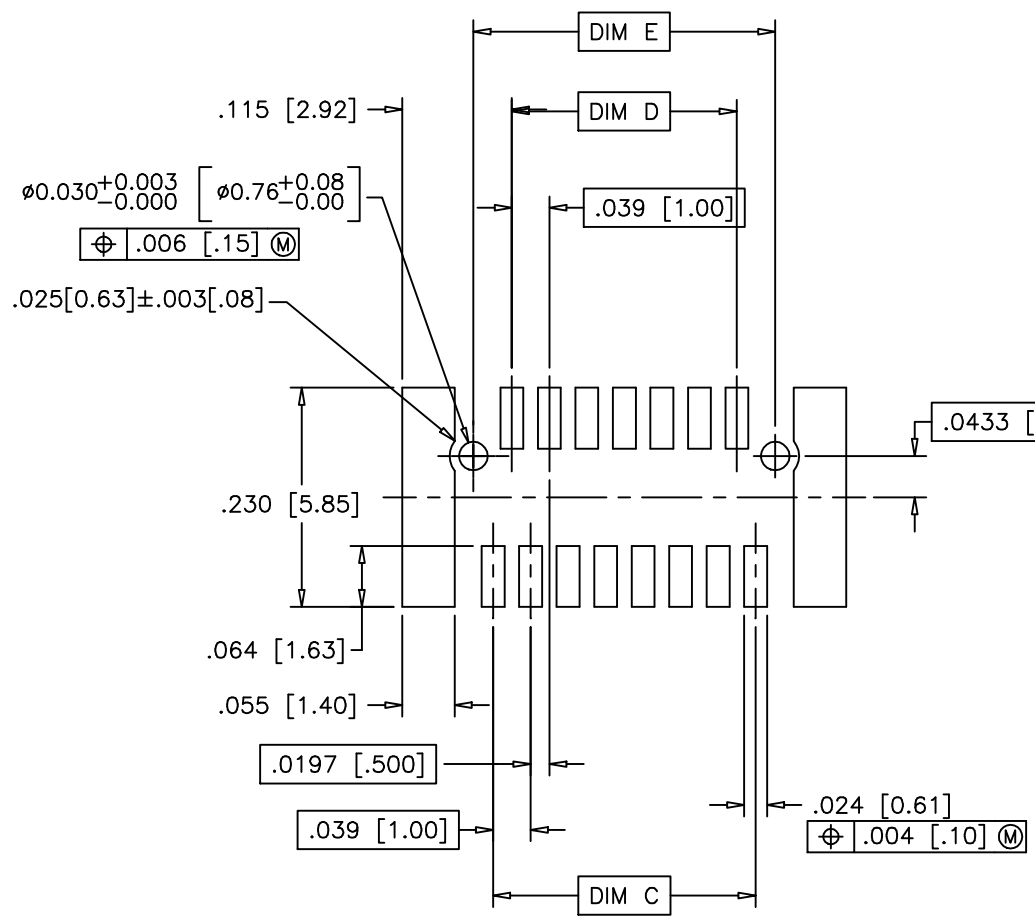

RECOMMENDED
PAD LAYOUT
FOR RECEPTACLE

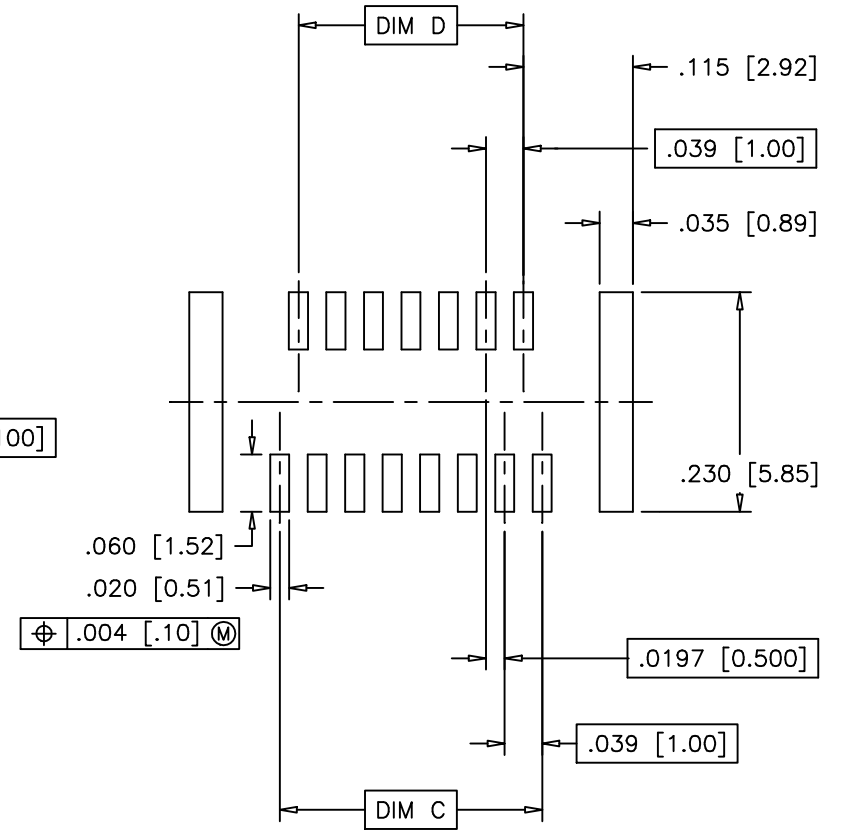

RECOMMENDED
STENCIL LAYOUT
FOR RECEPTACLE



Copyright FCI

mat'l. code		surface ISO 1302 ✓		tolerance ISO 406 ISO 1101		projection 		product family CONAN®	
ltr		ecn no		dr		date		title CONAN® CONNECTOR ASSEMBLY	
c								dwg no 10124017	
								sheet 3 of 7 size A3	
								type Product Customer Drawing	
sheet index		revision sheet							

PRODUCT NUMBER
SEE TABLE

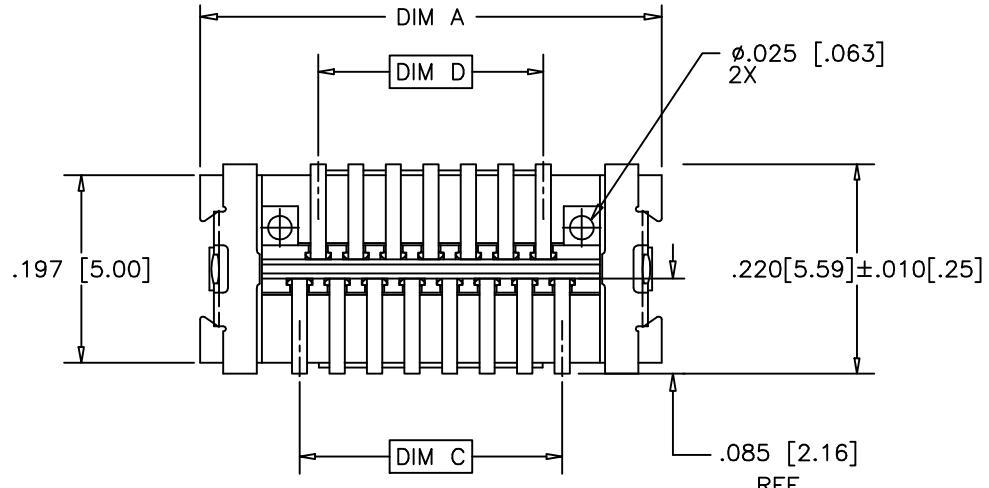

PLUG

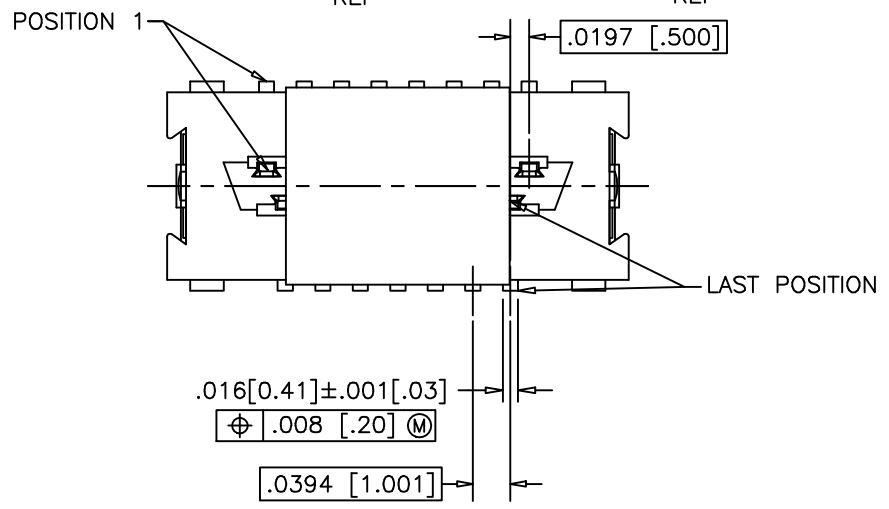
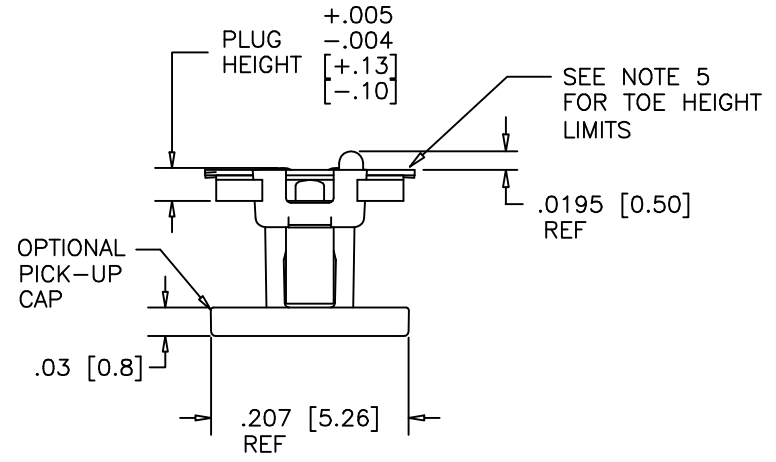
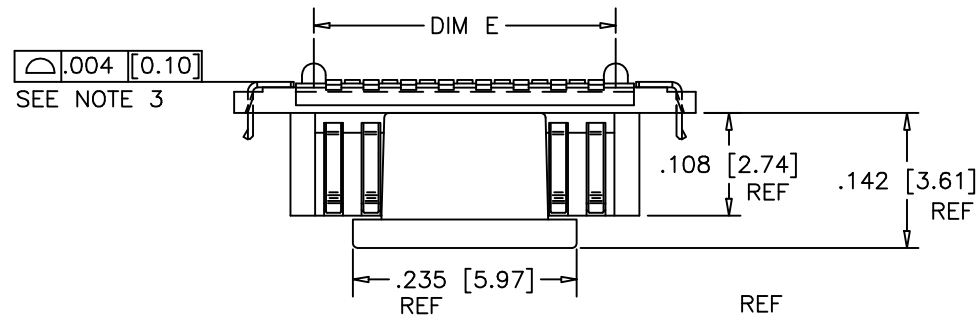

mat'l. code		surface ISO 1302 ✓		tolerance ISO 406 ISO 1101		projection ⊕		product family CONAN®	
ltr	ecn no	dr	date	tolerances unless otherwise specified				title	
c				angles	linear	INCH/MM		CONAN® CONNECTOR ASSEMBLY	
				0°±2°	XXX±.01/XX±0.3 XXX±.005/XX±0.13 XXXX±.0020/XXX±0.05	scale 5:1		dwg no 10124017 sheet 4 of 7 size A3	
		dr	GM SUN	2013-01-14			type Product Customer Drawing		
		enr	GM SUN	2013-01-14					
		chr	RICK BIAN	2013-01-14					
		appd	RICK BIAN	2013-01-14					
sheet index	revision sheet								



Copyright FCI

PRODUCT NUMBER
SEE TABLE

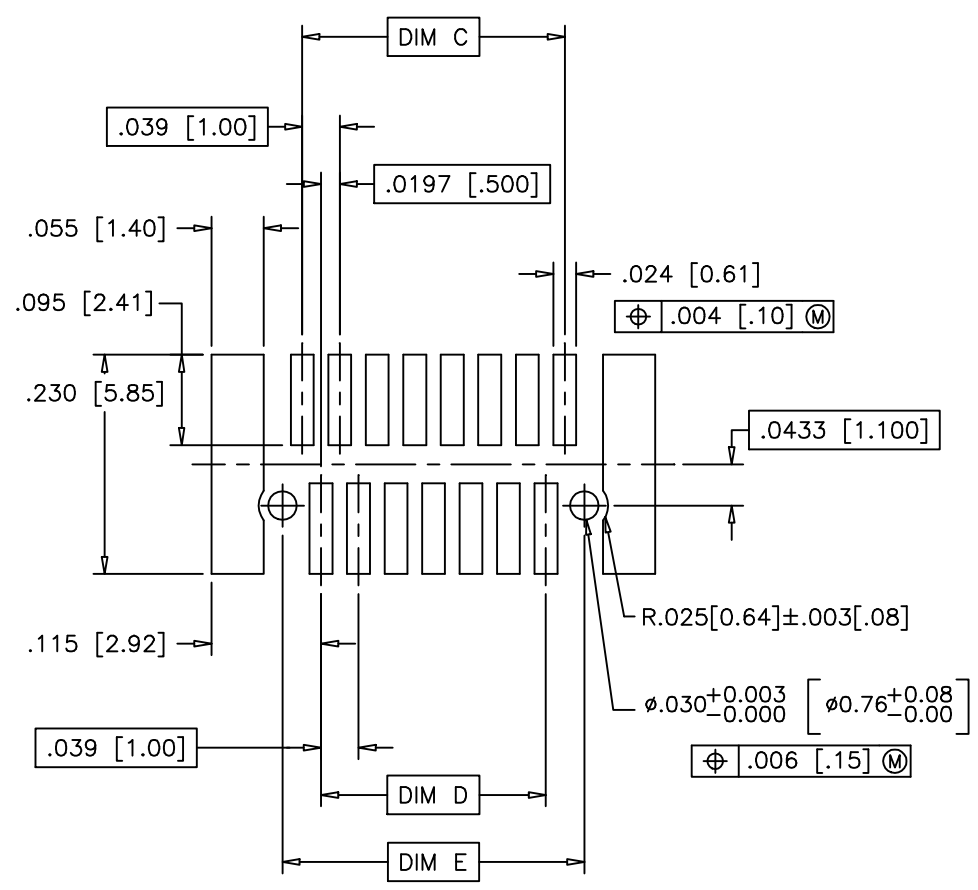

RECOMMENDED
PAD LAYOUT
FOR PLUG

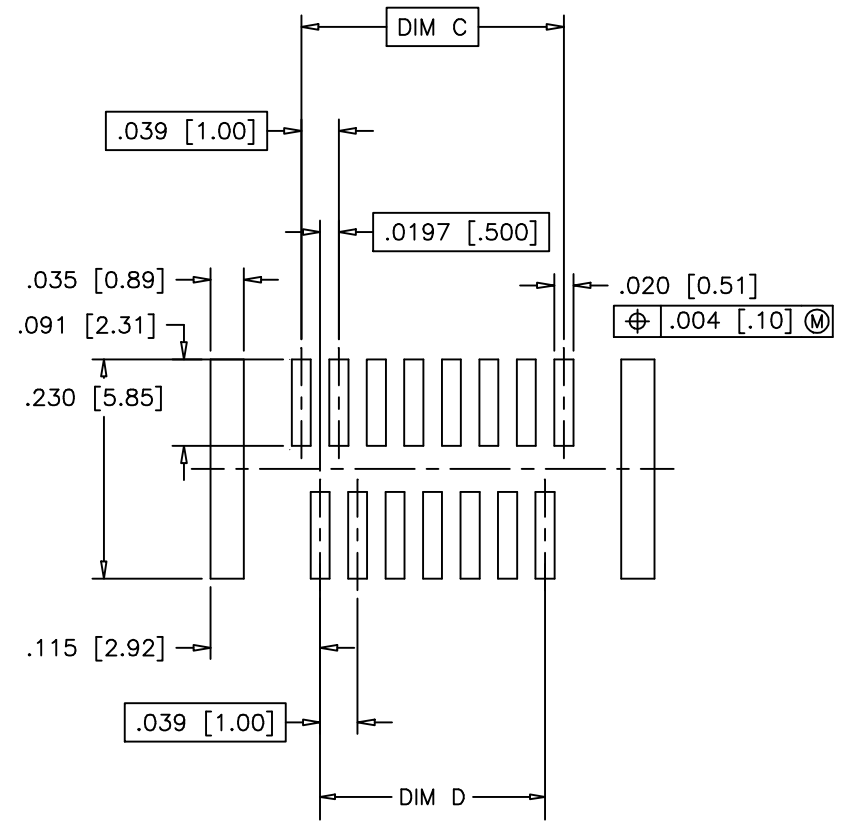

RECOMMENDED
STENCIL LAYOUT
FOR PLUG



Copyright FCI

mat'l. code		surface ISO 1302 ✓		tolerance ISO 406 ISO 1101		projection INCH/MM		product family CONAN®	
ltr		ecn no		dr		date		title	
c								CONAN® CONNECTOR ASSEMBLY	
		angles		linear		tolerances unless otherwise specified XXX±.01/XX±0.3 XXX±.005/XX±0.13 XXXX±.0020/XXX±0.05		scale 5:1	
		0°±2'						dwg no	
		dr		GM SUN		2013-01-14		sheet 5 of 7 size	
		enr		GM SUN		2013-01-14		10124017 A3	
		chr		RICK BIAN		2013-01-14		type	
		appd		RICK BIAN		2013-01-14		Product Customer Drawing	
sheet index		revision sheet							

PRODUCT NUMBER	POS	DIM "A"	DIM "C"	DIM "D"	DIM "E"
10124017-TCWXY09LF	9	.366 [9.30]	.157 [4.00]	.118 [3.00]	.1990 [5.055]
-TCWXY11LF	11	.406 [10.30]	.197 [5.00]	.157 [4.00]	.2380 [6.045]
-TCWXY15LF	15	.484 [12.30]	.276 [7.00]	.236 [6.00]	.3170 [8.052]
-TCWXY21LF	21	.602 [15.30]	.394 [10.00]	.354 [9.00]	.4350 [11.049]
-TCWXY25LF	25	.681 [17.30]	.472 [12.00]	.433 [11.00]	.5140 [13.056]
-TCWXY31LF	31	.800 [20.30]	.591 [15.00]	.551 [14.00]	.6320 [16.053]
-TCWXY41LF	41	.996 [25.30]	.787 [20.00]	.748 [19.00]	.8290 [21.057]
-TCWXY51LF	51	1.193 [30.30]	.984 [25.00]	.945 [24.00]	1.0260 [26.060]
-TCWXY69LF	69	1.547 [39.30]	1.339 [34.00]	1.299 [33.00]	1.3800 [35.052]

NOTES:

1. MATERIALS:

RECEPTACLE HOUSING - LCP, UL-94V-0. COLOR: NATURAL.

RECEPTACLE TERMINALS - COPPER ALLOY, PLATED WITH GOLD IN CONTACT AREA AND OTHER ALL AREA PLATING G/F WITH AN OVERALL 50µ"/1.27µ Ni UNDERPLATE.

PLUG HOUSING - LCP, UL-94V-0. COLOR: NATURAL.

PLUG TERMINALS - COPPER ALLOY, PLATED WITH GOLD IN CONTACT AREA AND OTHER ALL AREA PLATING G/F WITH AN OVERALL 50µ"/1.27µ Ni UNDERPLATE.

HOLD DOWN - COPPER ALLOY. PLATED WITH GOLD FLISH OVER NICKEL.

2. REFERENCE GS-12-0977 FOR PRODUCT PERFORMANCE AND ENVIRONMENTAL RESISTANCE DATA.

3. SEE TA-774 FOR FURTHER DESCRIPTION OF HOW THIS DIMENSION IS APPLIED.

4. RECOMMENDED SOLDER PASTE THICKNESS IS .006 TO .008 INCHES THICK.

5. THE TOE HEIGHT OF THE SOLDER TAIL SHALL BE MEASURED FROM THE LOWEST POINT OF THE .004 CO-PLANARITY GRAVITY PLANE. THIS MEASUREMENT IS NOT TO EXCEED A WINDOW OF .000 TO .007 INCHES.

6. THREE SLOTS MAY BE LOCATED AT EITHER END OF HOUSING.

7. THE HOUSING WILL WITHSTAND EXPOSURE TO 260°C PEAK TEMPERATURE FOR 30 SECONDS IN A CONVECTION INFRA RED OR VAPOR PHASE REFLOW OVEN. SEE APPLICATION/PROCEDURES IF THEY ARE AVAILABLE

8. PRODUCT WITH "LF" AT THE END MEETS EUROPEAN UNION DIRECTIVES AND OTHER COUNTRY REGULATION AS DESCRIBED IN GS-22-008.

FCIconnect.com

Copyright FCI

mat'l. code		surface ISO 1302	tolerance ISO 406 ISO 1101	projection 	product family CONAN®
ltr	ecn no	dr	date	tolerances unless otherwise specified	title CONAN® CONNECTOR ASSEMBLY
c				linear XXX±.01/XX±0.3 XXX±.005/XX±0.13 XXXX±.0020/XXX±0.05	INCH/MM scale 5:1
				dr	GM SUN 2013-01-14
				enr	GM SUN 2013-01-14
				chr	RICK BIAN 2013-01-14
				appd	RICK BIAN 2013-01-14
sheet index	revision sheet				dwg no 10124017 type Product Customer Drawing
					sheet 6 of 7 size A3

PRODUCT NUMBER
SEE TABLE

CONAN® ASSEMBLY PART NUMBER

10124017 - T C W X Y ZZ LF

LEAD FREE
SEE NOTE 8

TYPE	T
PLUG NO PEGS	0
PLUG WITH PEGS	1
RECEPTACLE NO PEGS	2
RECEPTACLE WITH PEGS	3

PICK AND PLACE CAP OR TAPE	C
WITHOUT CAP OR TAPE	0
WITH CAP	1
WITH TAPE (RECEPTACLE ONLY)	2

PACKAGING	W
TUBE	2
PRESSURE SEALED TAPE & REEL	3

Y	PLUG HEIGHT	RECEPTACLE HEIGHT	MATED HEIGHT	+0.10 -0.008 [+.25] [-.20]
1	.034 [.86]	.129 [3.28]	.163 [4.15]	
2	.048 [1.23]	SEE Y=1 FOR ALL RECEPTACLES	.177 [4.50]	
3	.068 [1.73]		.197 [5.00]	
4	.107 [2.72]		.236 [6.00]	
5	.1465 [3.721]		.276 [7.00]	

ZZ	NUMBER OF POSITIONS
09	9
11	11
15	15
21	21
25	25
31	31
41	41
51	51
69	69

X	PLATING
1	15u" Au ON CONTACT AREA, OTHER ALL AREA PLATING G/F.
2	30u" Au ON CONTACT AREA, OTHER ALL AREA PLATING G/F.

EXAMPLE: 10124017-3131125LF
IS A CONAN® RECEPTACLE ASSEMBLY,
HAVING PEGS AND WITH A PICK AND PLACE CAP.
IT IS .13 [3.2] HIGH AND 25 POSITIONS AND IS
PACKAGED IN PRESSURE SEALED TAPE, REEL AND LEAD FREE.

mat'l. code		surface ISO 1302	tolerance ISO 406 ISO 1101	projection 	product family CONAN®
ltr	ecn no	dr	date	title CONAN® CONNECTOR ASSEMBLY	
c				tolerances unless otherwise specified	dwg no
				angles linear XX±.01/XX±0.3 XXX±.005/XXX±0.13 XXXX±.0020/XXX±0.05	sheet 7 of 7 size
				0°±2'	10124017 A3
				dr GM SUN 2013-01-14	type Product Customer Drawing
				enr GM SUN 2013-01-14	
				chr RICK BIAN 2013-01-14	
				appd RICK BIAN 2013-01-14	
sheet index	revision sheet				



Copyright FCI



Компания «ЭлектроПласт» предлагает заключение долгосрочных отношений при поставках импортных электронных компонентов на взаимовыгодных условиях!

Наши преимущества:

- Оперативные поставки широкого спектра электронных компонентов отечественного и импортного производства напрямую от производителей и с крупнейших мировых складов;
- Поставка более 17-ти миллионов наименований электронных компонентов;
- Поставка сложных, дефицитных, либо снятых с производства позиций;
- Оперативные сроки поставки под заказ (от 5 рабочих дней);
- Экспресс доставка в любую точку России;
- Техническая поддержка проекта, помощь в подборе аналогов, поставка прототипов;
- Система менеджмента качества сертифицирована по Международному стандарту ISO 9001;
- Лицензия ФСБ на осуществление работ с использованием сведений, составляющих государственную тайну;
- Поставка специализированных компонентов (Xilinx, Altera, Analog Devices, Intersil, Interpoint, Microsemi, Aeroflex, Peregrine, Syfer, Eurofarad, Texas Instrument, Miteq, Cobham, E2V, MA-COM, Hittite, Mini-Circuits, General Dynamics и др.);

Помимо этого, одним из направлений компании «ЭлектроПласт» является направление «Источники питания». Мы предлагаем Вам помощь Конструкторского отдела:

- Подбор оптимального решения, техническое обоснование при выборе компонента;
- Подбор аналогов;
- Консультации по применению компонента;
- Поставка образцов и прототипов;
- Техническая поддержка проекта;
- Защита от снятия компонента с производства.



Как с нами связаться

Телефон: 8 (812) 309 58 32 (многоканальный)

Факс: 8 (812) 320-02-42

Электронная почта: org@eplast1.ru

Адрес: 198099, г. Санкт-Петербург, ул. Калинина, дом 2, корпус 4, литера А.