

THIS DRAWING IS UNPUBLISHED. RELEASED FOR PUBLICATION
 © COPYRIGHT - By - ALL RIGHTS RESERVED.

LOC		DIST		REVISIONS			
P	LTR	DESCRIPTION	DATE	DWN	APVD		
AD	00	A7	REVISED PER ECO-14-005988	23APR2014	NK	RH	

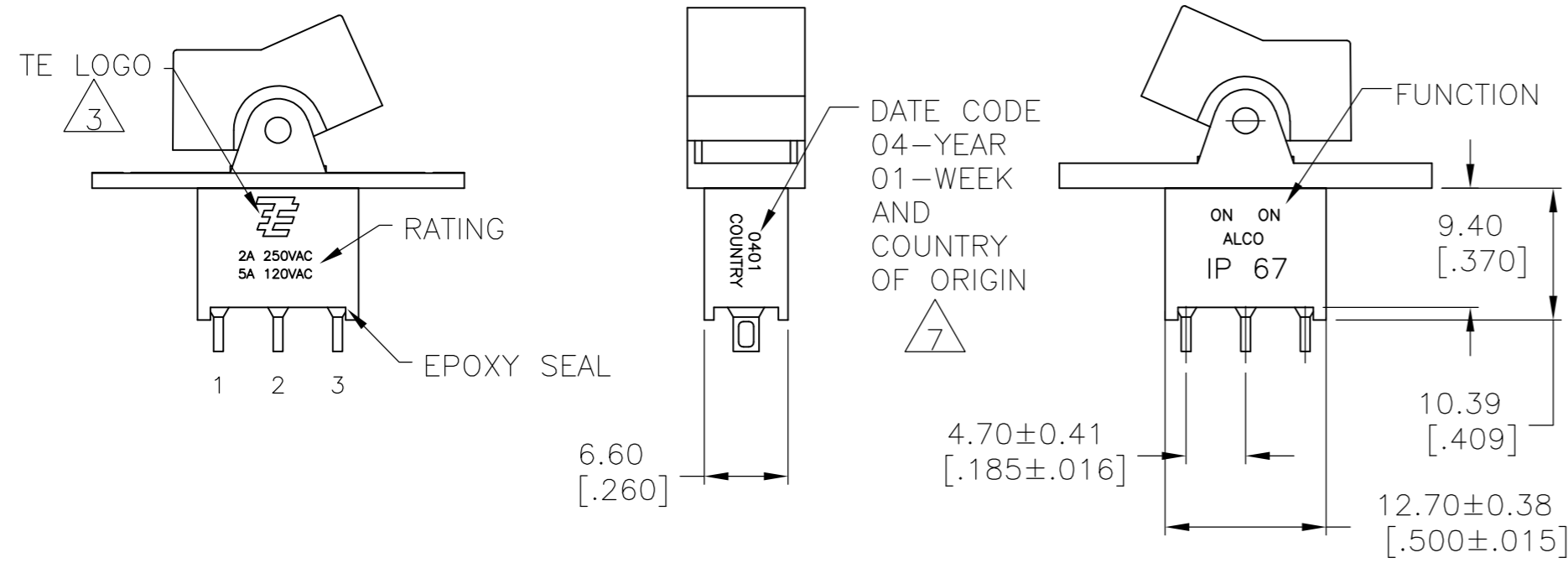

- ALL MATERIALS AND FINISHES SHALL COMPLY WITH EU DIRECTIVE 2002/95/EC OF 27JAN2003 (ROHS).
- G CONTACT OPTION CAN BE USED FOR SIGNAL OR POWER LEVEL SWITCHING. IF SWITCH IS USED AT LEVELS EXCEEDING .4VA @ 20V AC/DC, SWITCH IS RENDERED FOR POWER SWITCHING ONLY DUE TO ARC REMOVAL OF GOLD PLATING. RATING MARKED ON THE SWITCH IS 2A 250VAC, 5A 120VAC.
- TE LOGO PER TEC-202-36.
- SWITCHES MEET REQUIREMENTS OF IP67
- PANEL MOUNT ACTUATOR PIVOT SUPPLIED WITH C, W, W4, Z & Z3 TERMINATIONS. PC MOUNT ACTUATOR PIVOT SUPPLIED WITH A, AV2, V3 & V4 TERMINATIONS
- DATE CODE AND COUNTRY OF ORIGIN MAY APPEAR ON EITHER SIDE OF SWITCH.
- ALL LOGO, RATING, DATE CODE, AND FUNCTION MARKINGS TO BE LASER MARKED.

FUNCTION CHART

FUNCTION			
01	ON	NONE	ON
03	ON	OFF	ON
05	(ON)	OFF	(ON)
07	ON	OFF	(ON)
08	ON	NONE	(ON)
TERMINALS CONNECTED	2-3	---	1-2

NONE: NO MECHANICAL POSITION
 OFF: MECHANICAL POSITION WITH NO ELECTRICAL CONNECTION
 (ON): MOMENTARY ACTION

SPECIFICATIONS

RATING, B CONTACTS	.4VA MAX @20V MAX. AC OR DC
RATING, G CONTACTS-SEE NOTE 2	.4VA MAX @20V MAX. AC OR DC OR
	5A @120 VAC OR 28 VDC (RESISTIVE)
RATING, Q CONTACTS	2A @250 VAC (RESISTIVE)
	5A @120 VAC OR 28 VDC (RESISTIVE)
ELECTRICAL LIFE	6,000 CYCLES AT RATED LOAD
CONTACT RESISTANCE	10 MILLIOHMS MAX INITIAL @ 2-4VDC, 100MA
INSULATION RESISTANCE	1,000 MEGOHMS MIN
DIELECTRIC WITHSTANDING VOLTAGE	1,000 V RMS AT SEA LEVEL
OPERATING TEMPRATURE	-30C TO 85C

PART NUMBER SEQUENCE

MODEL	FUNCTION	TOGGLE	TERMINAL	CONTACT	ACTUATOR COLOR	ROHS
AE1						04
	01	J1	A	B	0 BLACK (STD)	
	03	J50	AV2	G	1 BROWN	
	05	J2	C	Q	2 RED	
	07	J60	V3		3 ORANGE	
	08		V4		4 YELLOW	
			W		5 GREEN	
			W4		6 BLUE	
			Z		8 GRAY	
			Z3		9 WHITE	

THIS DRAWING IS A CONTROLLED DOCUMENT.		DWN	M.BINNER	06JAN05		TE Connectivity		
DIMENSIONS: mm [INCHES]		CHK	M.ZITTO	06JAN05		NAME		
TOLERANCES UNLESS OTHERWISE SPECIFIED:		APVD	M.ZITTO	06JAN05		GEMINI AE SERIES ROCKER SWITCH SINGLE POLE		
0 PLC ± -		PRODUCT SPEC				SIZE	CAGE CODE	DRAWING NO
1 PLC ± -		APPLICATION SPEC			A2	00779	C=1571988	
2 PLC ± -					SCALE		SHEET	
3 PLC ± .010					2:1		1 of 5	
4 PLC ± -					REV		A7	
ANGLES ± 4°					CUSTOMER DRAWING			
FINISH								

THIS DRAWING IS UNPUBLISHED. RELEASED FOR PUBLICATION
 © COPYRIGHT - By - ALL RIGHTS RESERVED.

LOC	DIST	REVISIONS					
AD	00	P	LTR	DESCRIPTION	DATE	DWN	APVD
		-	-	SEE SHEET 1	-	-	-

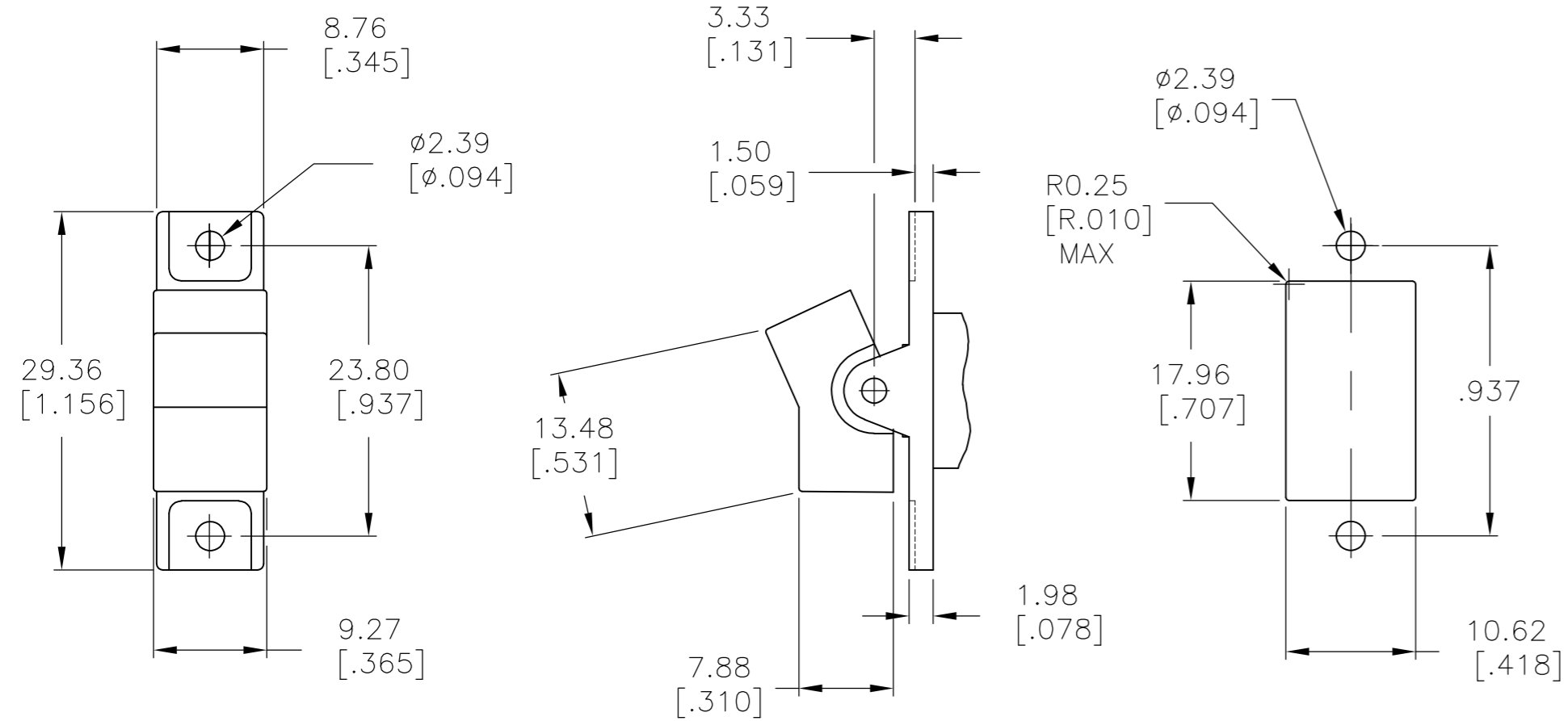

J1 SHOWN WITH PANEL MOUNT ACTUATOR PIVOT

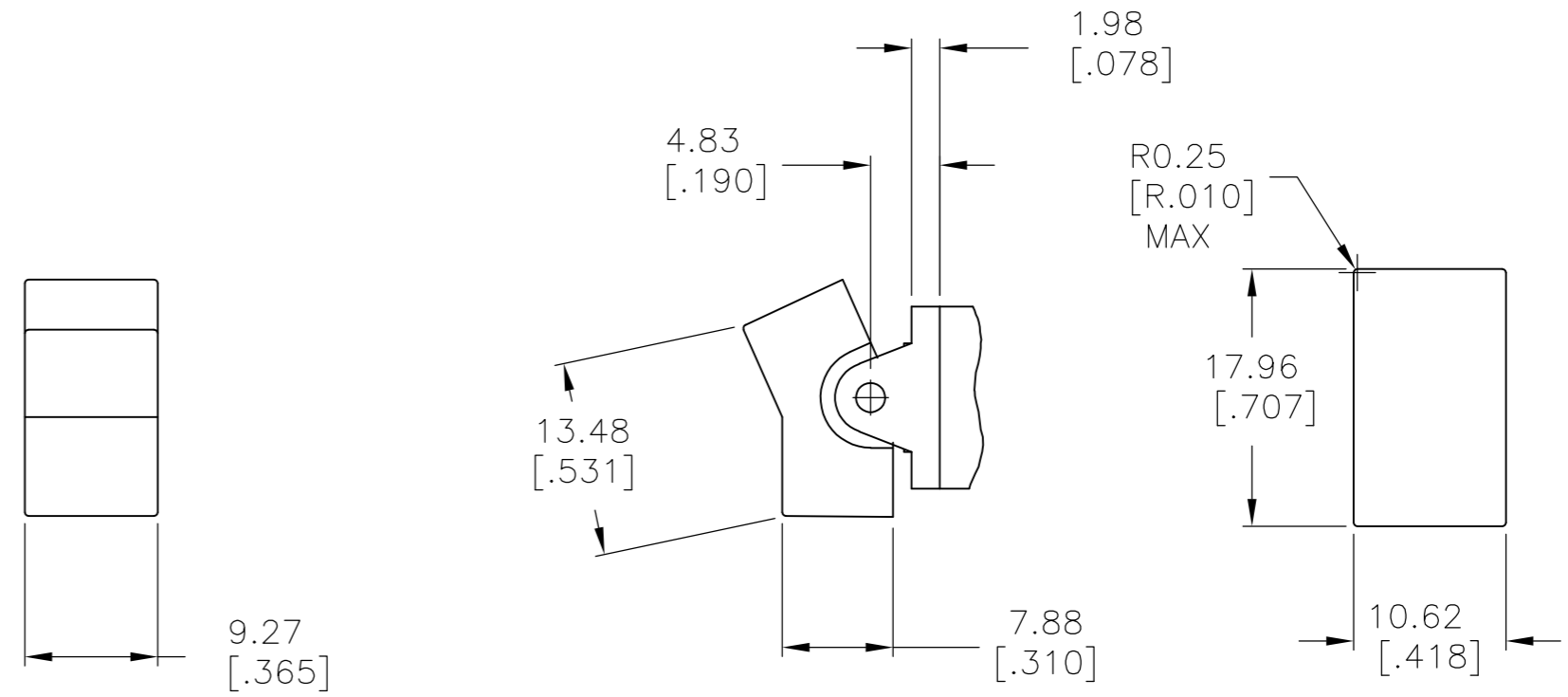

J1 SHOWN WITH PC MOUNT ACTUATOR PIVOT

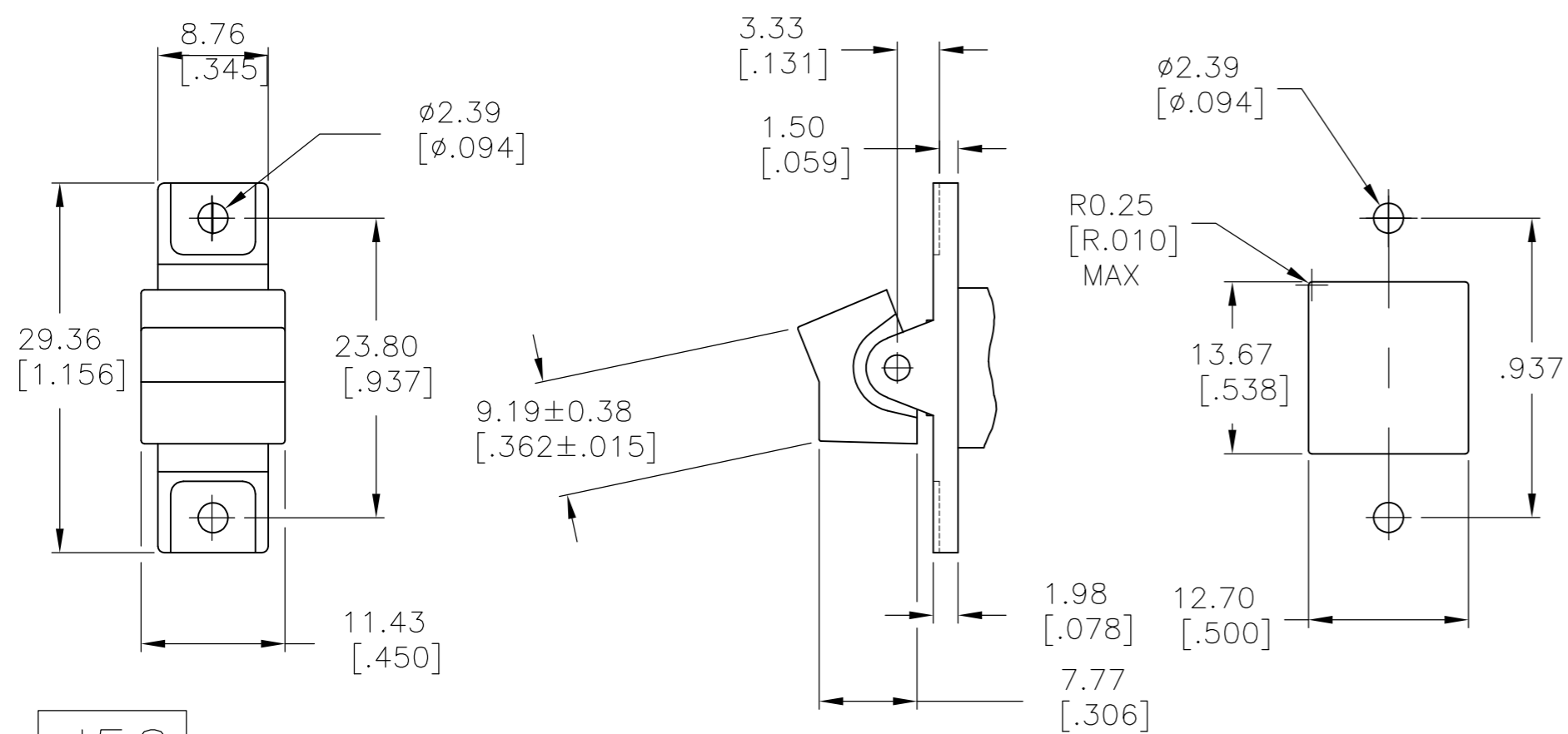

J50 SHOWN WITH PANEL MOUNT ACTUATOR PIVOT

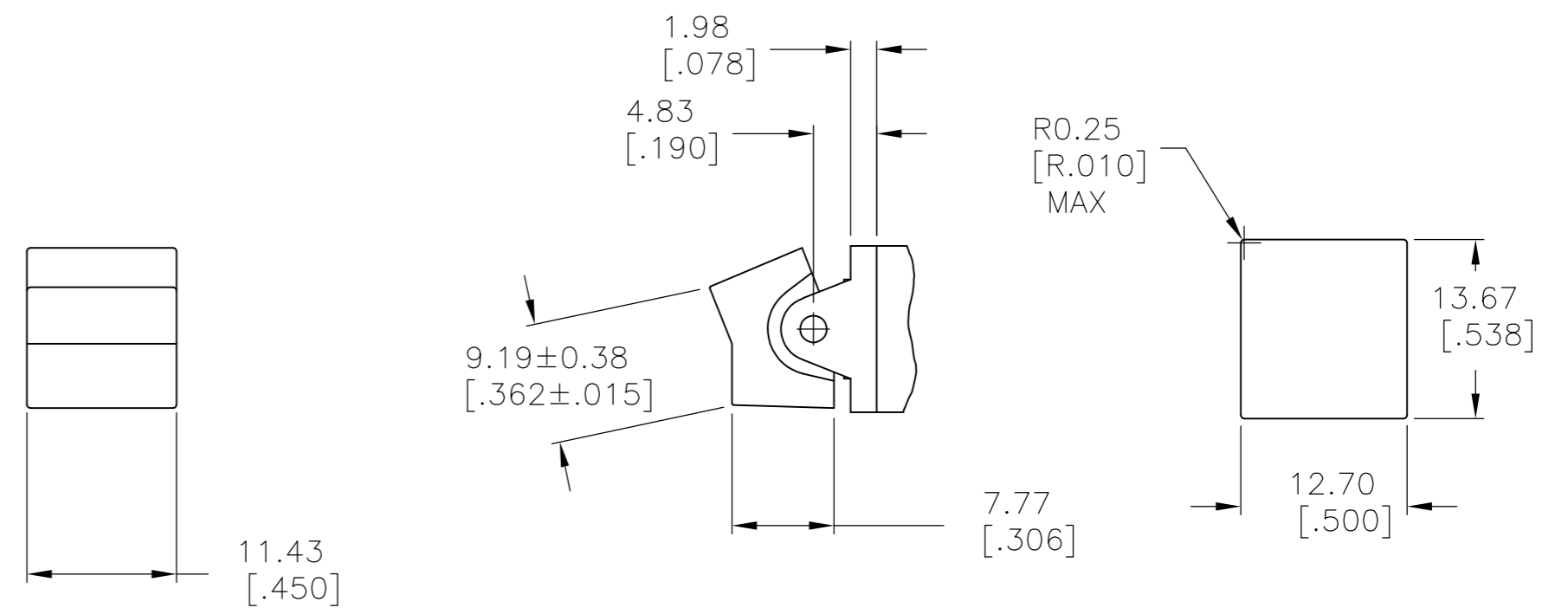

J50 SHOWN WITH PC MOUNT ACTUATOR PIVOT

1.52-3.17 [.060-.125]	15.75-15.87 [.620-.625]
1.19-1.50 [.047-.059]	15.72 [.619]
PANEL THICKNESS	DIM "A"

THIS DRAWING IS A CONTROLLED DOCUMENT.		DWN M.BINNER 06JAN05	TE Connectivity	
DIMENSIONS: mm [INCHES]		CHK M.ZITTO 06JAN05		
TOLERANCES UNLESS OTHERWISE SPECIFIED:		APVD M.ZITTO 06JAN05	NAME GEMINI AE SERIES ROCKER SWITCH SINGLE POLE	
0 PLC ± -		PRODUCT SPEC	SIZE	
1 PLC ± -		APPLICATION SPEC	CAGE CODE	
2 PLC ± -			DRAWING NO	
3 PLC ± .010			RESTRICTED TO	
4 PLC ± -			A2 00779 C=1571988	
ANGLES ± 4°			SCALE 2:1 SHEET 2 OF 5 REV A7	
MATERIAL		WEIGHT	CUSTOMER DRAWING	
FINISH				

THIS DRAWING IS UNPUBLISHED. RELEASED FOR PUBLICATION
 © COPYRIGHT - By - ALL RIGHTS RESERVED.

LOC		DIST		REVISIONS			
P	LTR	DESCRIPTION	DATE	DWN	APVD		
-	-	SEE SHEET 1	-	-	-		

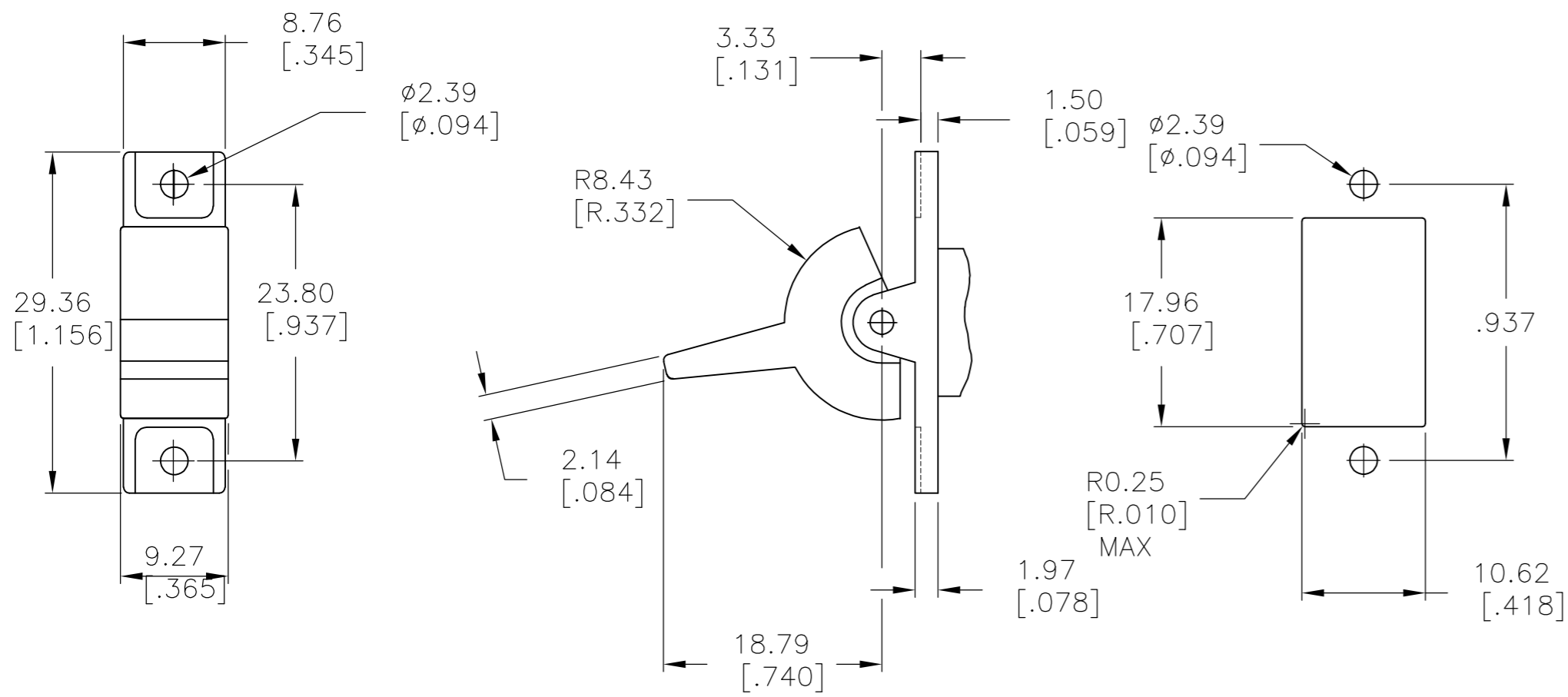

J2 SHOWN WITH PANEL MOUNT ACTUATOR PIVOT

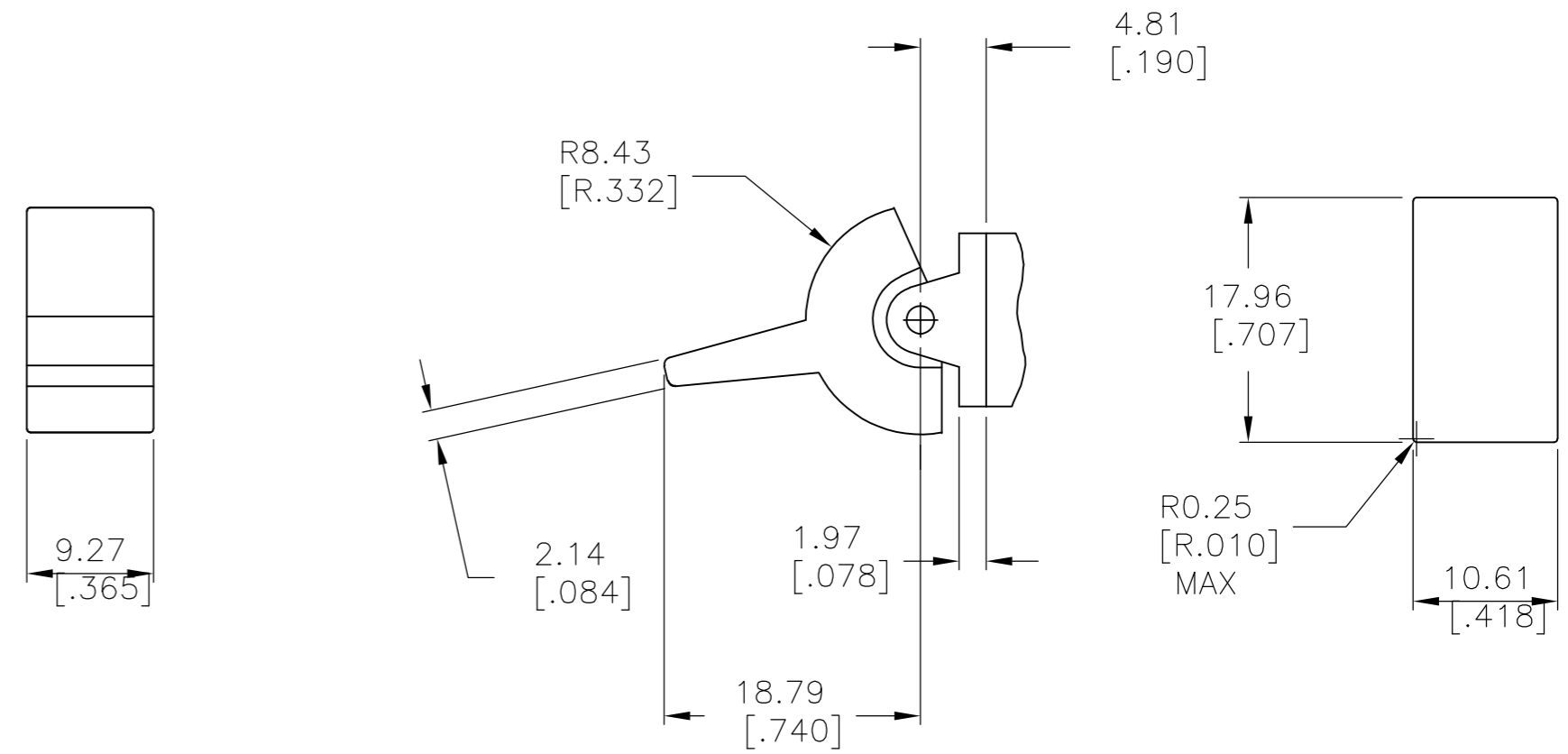

J2 SHOWN WITH PC MOUNT ACTUATOR PIVOT

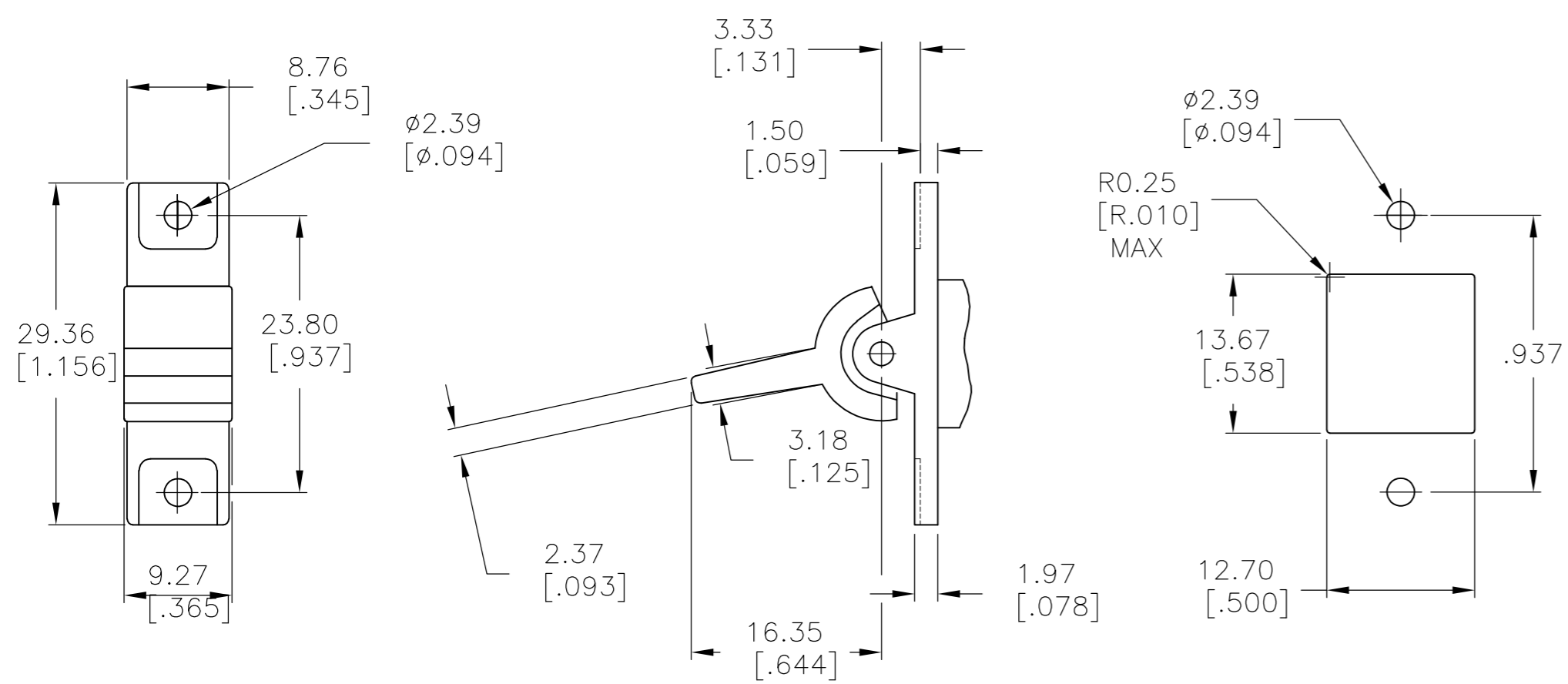

J60 SHOWN WITH PANEL MOUNT ACTUATOR PIVOT

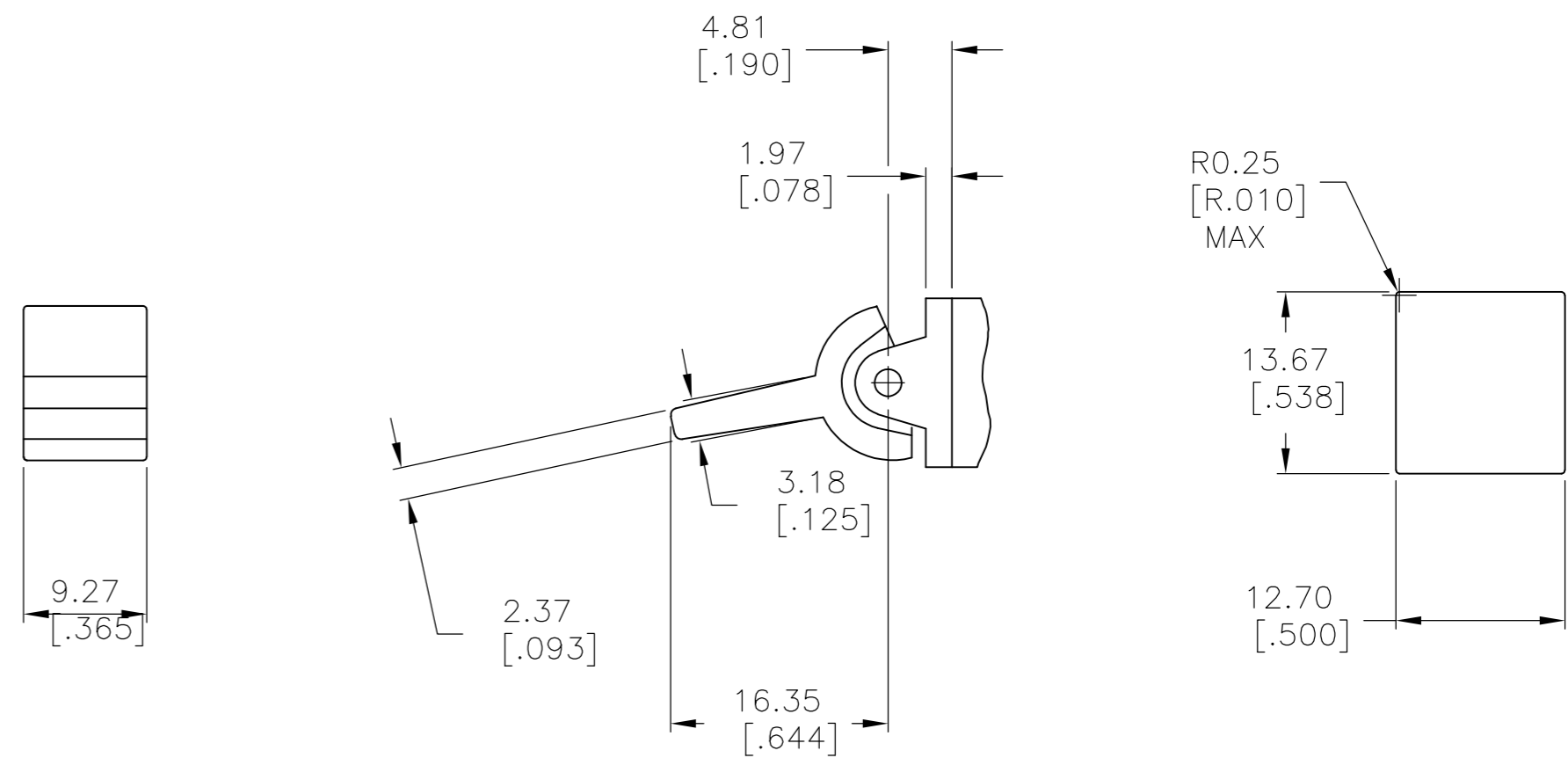

J60 SHOWN WITH PC MOUNT ACTUATOR PIVOT

1.52-3.17 [.060-.125]	15.75-15.87 [.620-.625]
1.19-1.50 [.047-.059]	15.72 [.619]
PANEL THICKNESS	DIM "A"

THIS DRAWING IS A CONTROLLED DOCUMENT.		DWN	M.BINNER	06JAN05	TE Connectivity
DIMENSIONS:		CHK	M.ZITTO	06JAN05	
mm [INCHES]		APVD	M.ZITTO	06JAN05	
TOLERANCES UNLESS OTHERWISE SPECIFIED:		PRODUCT SPEC	NAME		
0 PLC	± -	APPLICATION SPEC	GEMINI AE SERIES ROCKER SWITCH SINGLE POLE		
1 PLC	± -	WEIGHT	-		
2 PLC	± -	CUSTOMER DRAWING	-		
3 PLC	± .010	SCALE	2:1		
4 PLC	± -	SHEET	3 of 5		
ANGLES	± 4°	REV	A7		
MATERIAL	FINISH	A2 00779 C=1571988			RESTRICTED TO

THIS DRAWING IS UNPUBLISHED. RELEASED FOR PUBLICATION
 © COPYRIGHT - By - ALL RIGHTS RESERVED.

LOC		DIST		REVISIONS				
P	LTR	DESCRIPTION	DATE	DWN	APVD			
AD	00	SEE SHEET 1	-	-	-			

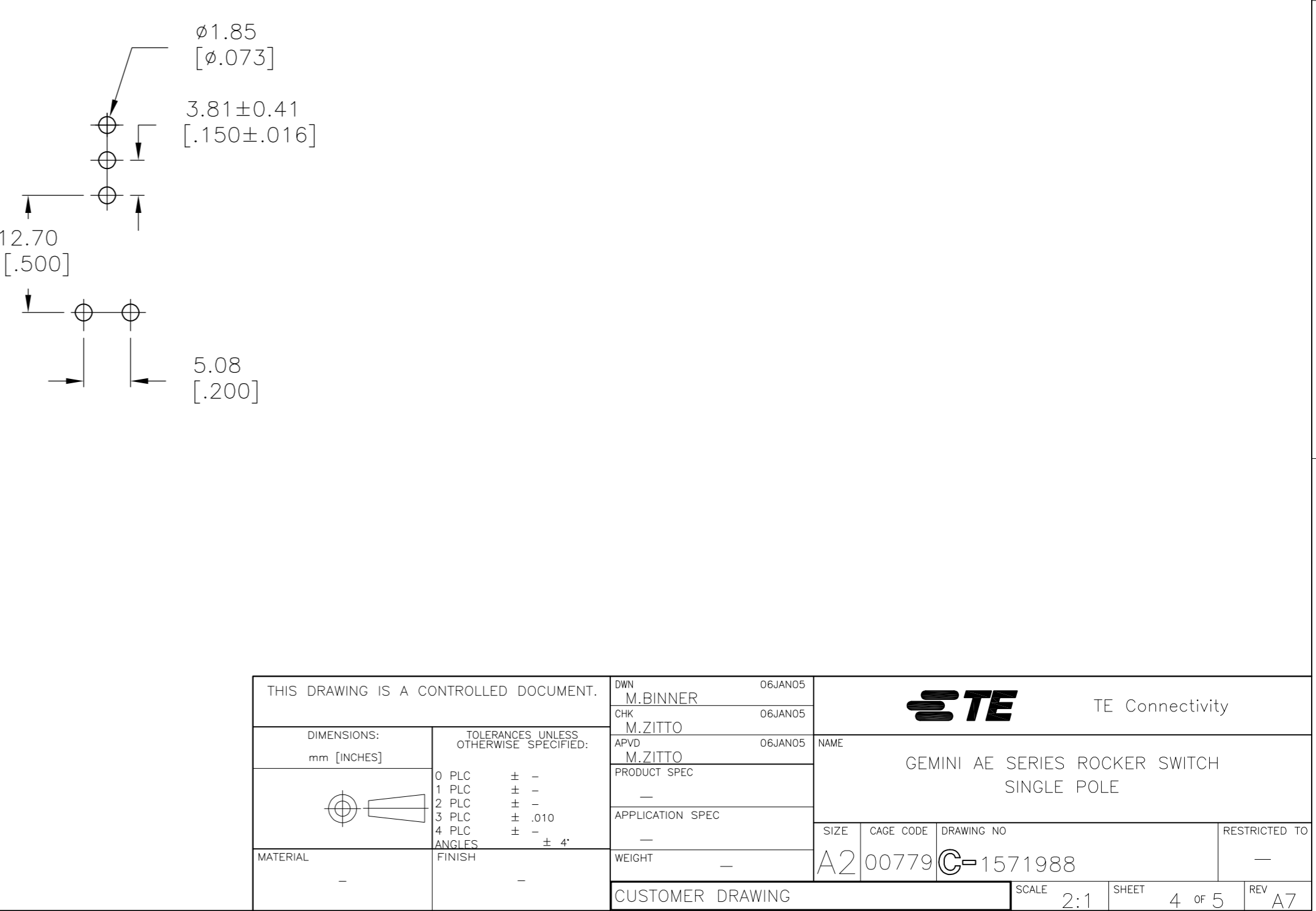
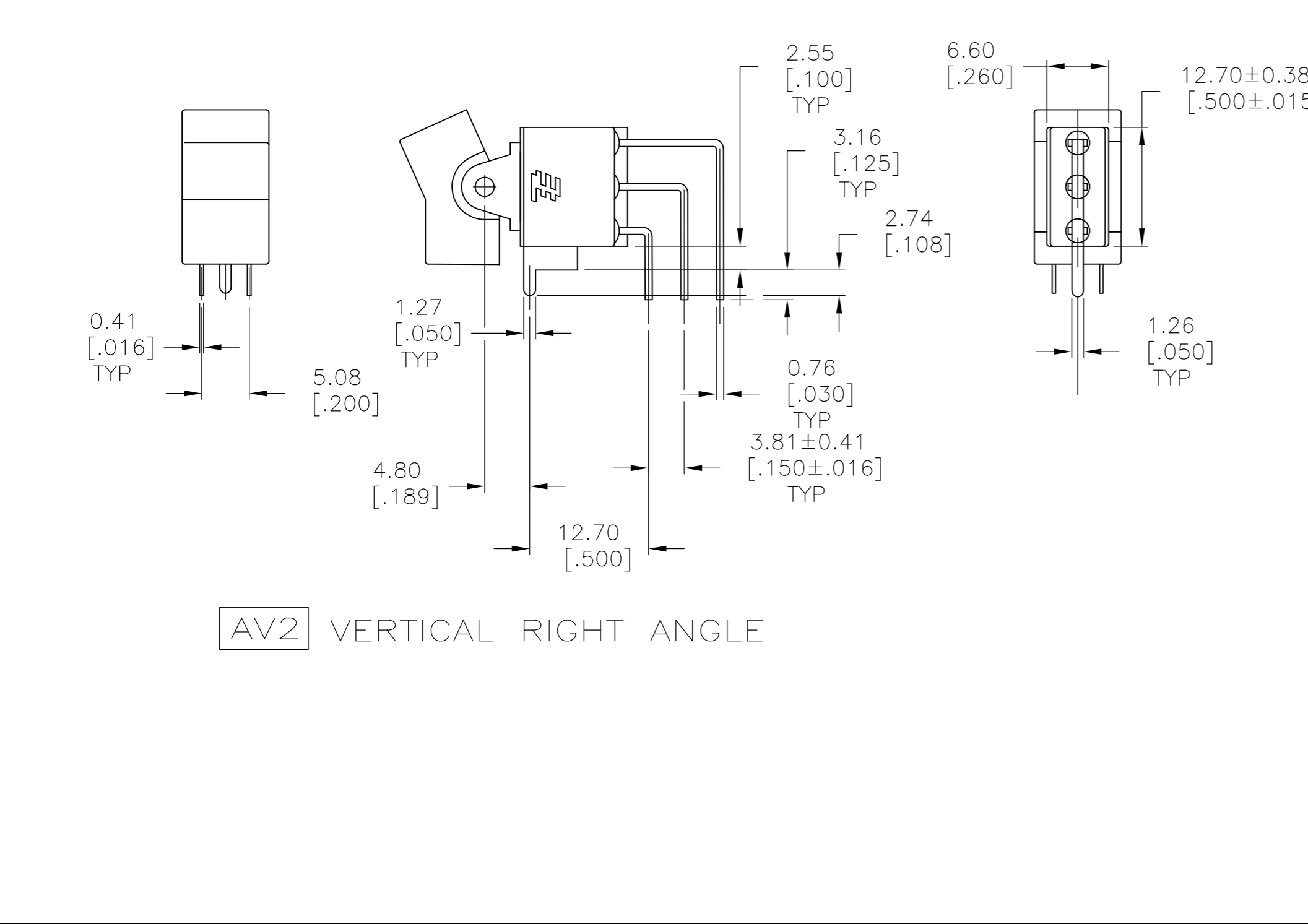
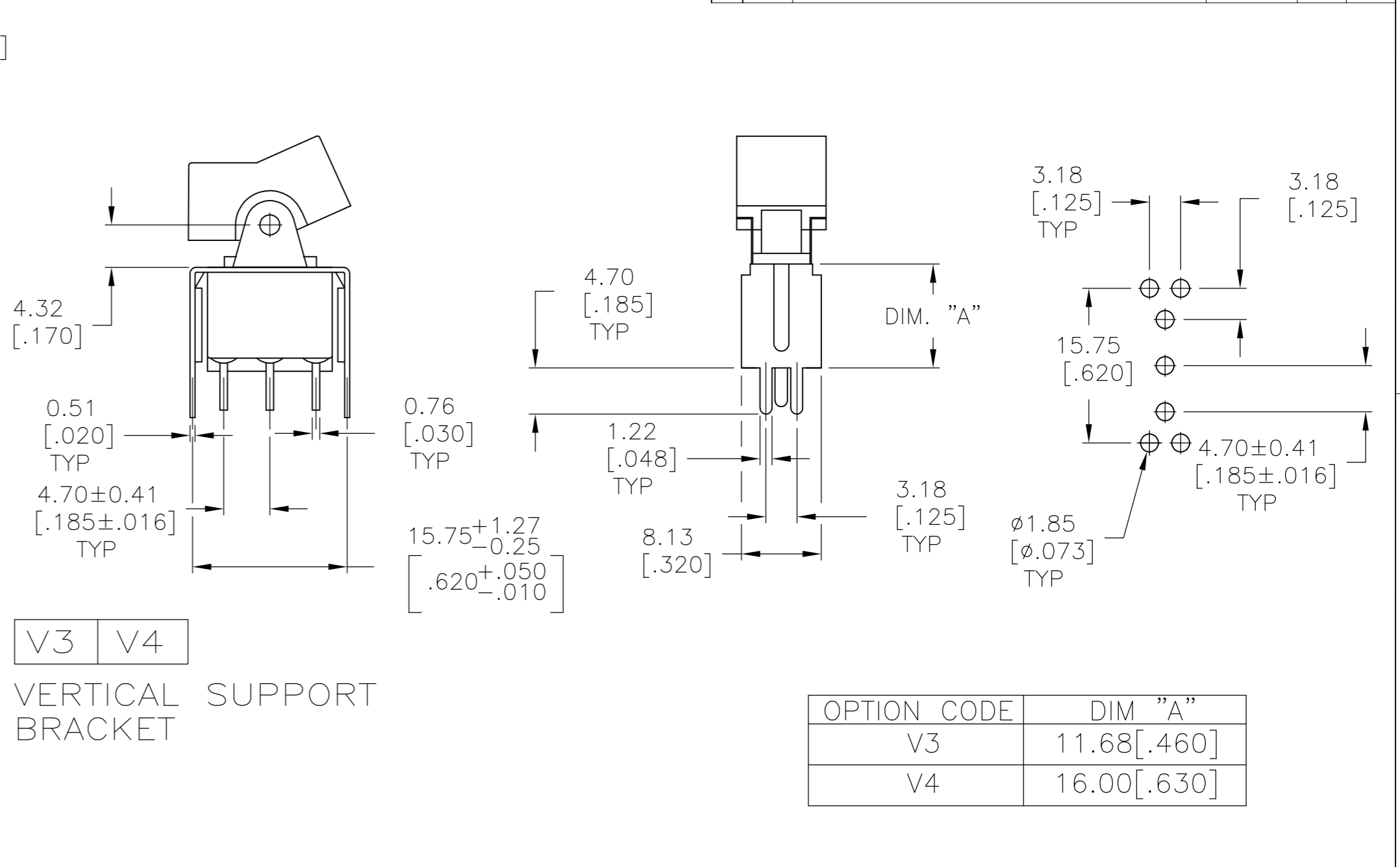
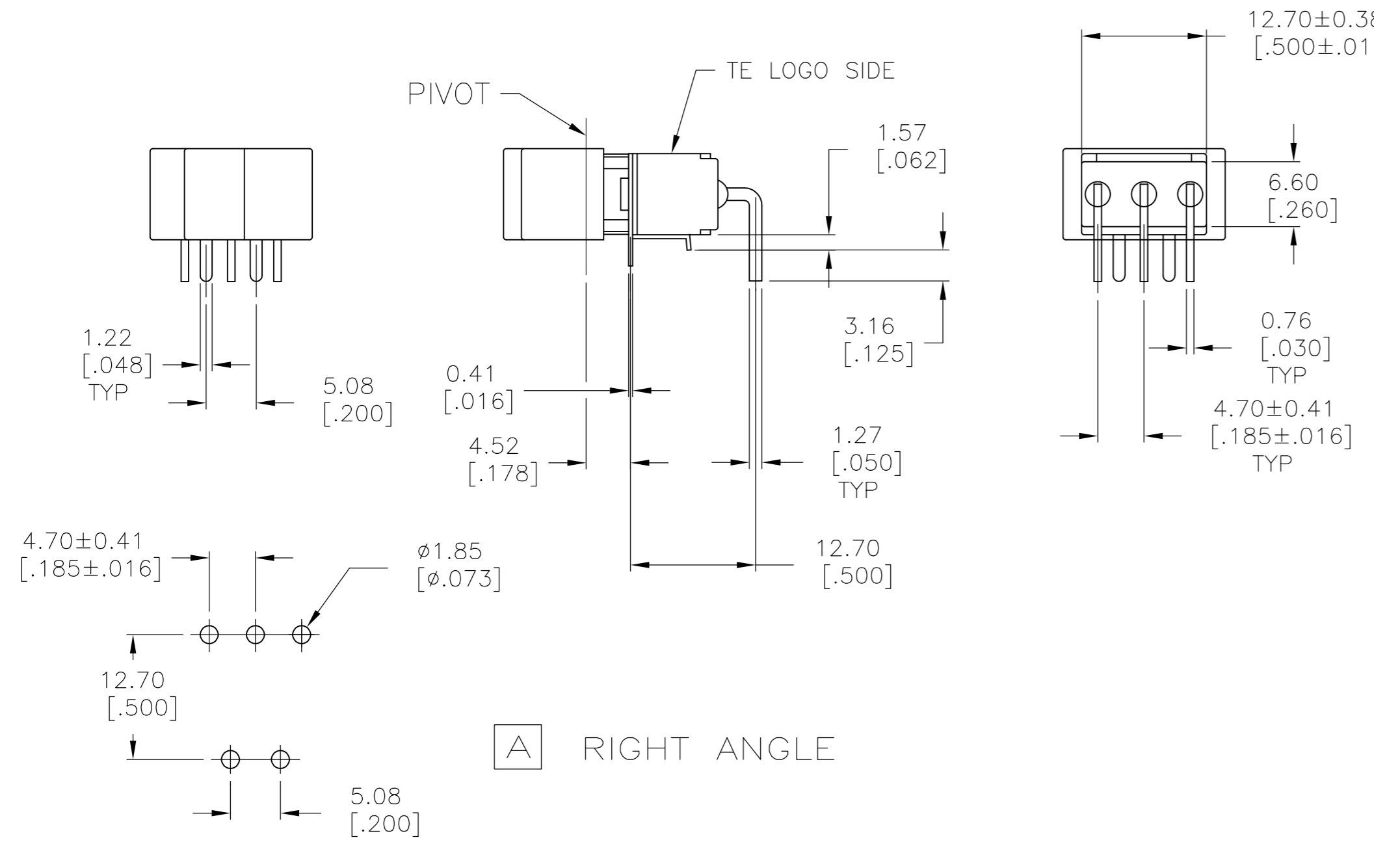

THIS DRAWING IS A CONTROLLED DOCUMENT.		DWN	M.BINNER	06JAN05		TE Connectivity		
DIMENSIONS:		CHK	M.ZITTO	06JAN05		NAME		
mm [INCHES]		APVD	M.ZITTO	06JAN05		GEMINI AE SERIES ROCKER SWITCH		
TOLERANCES UNLESS OTHERWISE SPECIFIED:		PRODUCT SPEC	APPLICATION SPEC			SINGLE POLE		
0 PLC ± -		MATERIAL		WEIGHT	SIZE	CAGE CODE	DRAWING NO	RESTRICTED TO
1 PLC ± -		FINISH		-	A2	00779	C=1571988	-
2 PLC ± -					SCALE		SHEET	REV
3 PLC ± .010					2:1		4 OF 5	A7
4 PLC ± -					CUSTOMER DRAWING			
ANGLES ± 4°								

THIS DRAWING IS UNPUBLISHED. RELEASED FOR PUBLICATION
 © COPYRIGHT - By - ALL RIGHTS RESERVED.

LOC	DIST	REVISIONS			
P	LTR	DESCRIPTION	DATE	DWN	APVD
AD	00	SEE SHEET 1	-	-	-

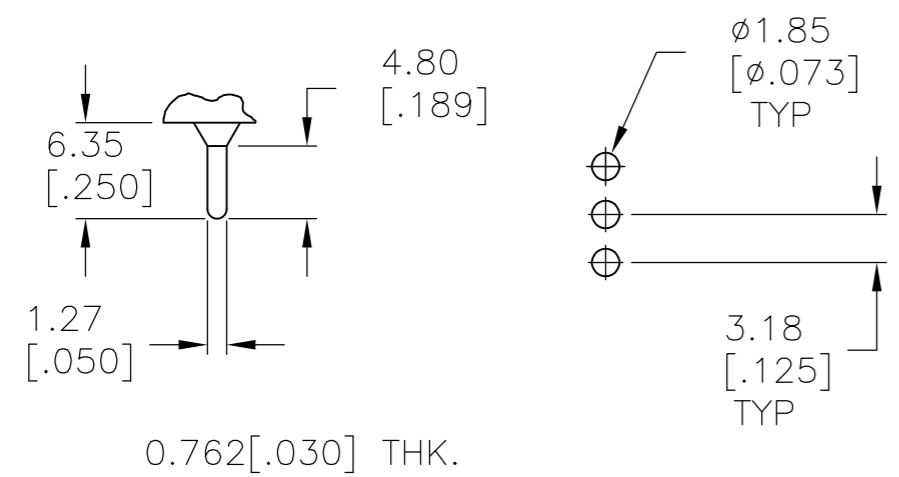

C PRINTED CIRCUIT

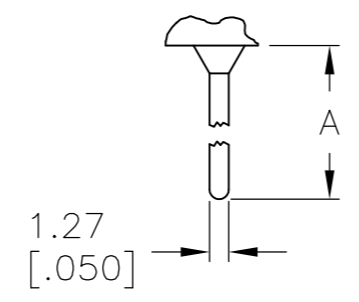

OPTION	DIM A
W	18.69 [.736]
W4	26.97 [1.062]

W **W4** WIRE WRAP

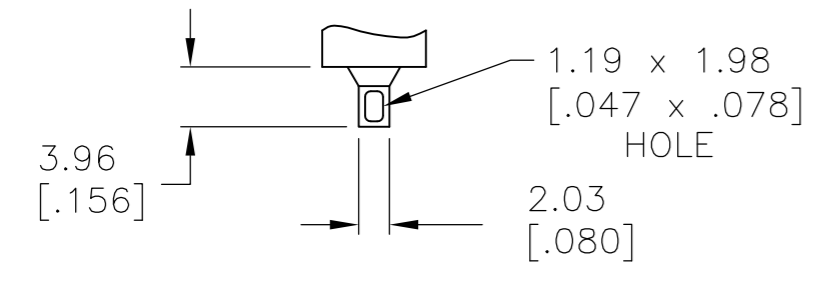

Z WIRE LUG

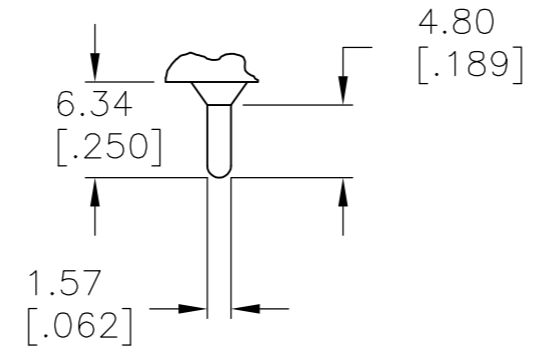

Z3 QUICK CONNECT

MATERIALS CHART

COMPONENT NAME	BASE MATERIAL	FINISH
CASE & BUSHING	NYLON, RED, UL94 V-0	
O-RING	PVC, BLACK	
B TERMINALS & CONTACTS	COPPER	GOLD NICKEL
G TERMINALS & CONTACTS	COPPER	GOLD OVER SILVER
Q TERMINALS & CONTACTS	COPPER	SILVER
ACTUATOR	PHENOLIC, BLACK, UL94 V-1	
ACTUATOR LEVER	ZINC ALLOY	NICKEL
SPRING	MUSIC WIRE	
PIVOT PIN	STEEL	NICKEL
MOUNTING BRACKET	NYLON, UL94 V-1	
ROCKER CAP	NYLON, UL94 V-1	
TERMINAL SEAL	EPOXY, UL94V-0	
MARKING	INK, BLACK	
SUPPORT BRACKET	BRASS	TIN
RETAINER	STAINLESS STEEL	

PRELIMINARY	AE101J3V31Q004	1-1571988-7
	AE108J60V3B004	1-1571988-6
	AE108J1ZQ004	1-1571988-5
	AE107J1ZQ004	1-1571988-4
	AE107J1AQ004	1-1571988-3
	AE105J60V3B004	1-1571988-2
	AE105J1ZB004	1-1571988-1
	AE105J1V3B004	1-1571988-0
	AE105J1AQ004	1571988-9
	AE103J60V3Q204	1571988-8
	AE103J50V3B004	1571988-7
	AE101J1V3Q004	1571988-6
	AE101J1V3B004	1571988-5
	AE101J1AV2Q004	1571988-4
	AE101J1AQ404	1571988-3
	AE101J1AQ004	1571988-2
	AE101J1AB004	1571988-1
	ALCO P/N	TE P/N

THIS DRAWING IS A CONTROLLED DOCUMENT.

DWN	M.BINNER	06JAN05
CHK	M.ZITTO	06JAN05
APVD	M.ZITTO	06JAN05

TE TE Connectivity

NAME: GEMINI AE SERIES ROCKER SWITCH SINGLE POLE

SIZE	A2	CAGE CODE	00779	DRAWING NO	C=1571988	RESTRICTED TO	-	
CUSTOMER DRAWING			SCALE	2:1	SHEET	5 of 5	REV	A7

1571988

B

A



Компания «ЭлектроПласт» предлагает заключение долгосрочных отношений при поставках импортных электронных компонентов на взаимовыгодных условиях!

Наши преимущества:

- Оперативные поставки широкого спектра электронных компонентов отечественного и импортного производства напрямую от производителей и с крупнейших мировых складов;
- Поставка более 17-ти миллионов наименований электронных компонентов;
- Поставка сложных, дефицитных, либо снятых с производства позиций;
- Оперативные сроки поставки под заказ (от 5 рабочих дней);
- Экспресс доставка в любую точку России;
- Техническая поддержка проекта, помощь в подборе аналогов, поставка прототипов;
- Система менеджмента качества сертифицирована по Международному стандарту ISO 9001;
- Лицензия ФСБ на осуществление работ с использованием сведений, составляющих государственную тайну;
- Поставка специализированных компонентов (Xilinx, Altera, Analog Devices, Intersil, Interpoint, Microsemi, Aeroflex, Peregrine, Syfer, Eurofarad, Texas Instrument, Miteq, Cobham, E2V, MA-COM, Hittite, Mini-Circuits, General Dynamics и др.);

Помимо этого, одним из направлений компании «ЭлектроПласт» является направление «Источники питания». Мы предлагаем Вам помощь Конструкторского отдела:

- Подбор оптимального решения, техническое обоснование при выборе компонента;
- Подбор аналогов;
- Консультации по применению компонента;
- Поставка образцов и прототипов;
- Техническая поддержка проекта;
- Защита от снятия компонента с производства.



Как с нами связаться

Телефон: 8 (812) 309 58 32 (многоканальный)

Факс: 8 (812) 320-02-42

Электронная почта: org@eplast1.ru

Адрес: 198099, г. Санкт-Петербург, ул. Калинина, дом 2, корпус 4, литера А.