

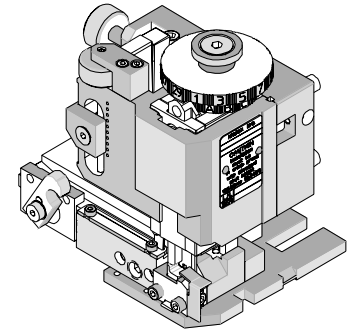

## FineAdjust Applicator Specification Sheet Part No. 63860-1500



### FEATURES

- Quick punch removal with the push of a button for fast and easy tooling change
- Applicator designed to industry standard mounting and shut height 135.80mm (5.346")
- Quick set-up time; plus the crimp height, track and feed adjustments can be set without removing the applicator from the press
- Fine adjustment allows users to achieve target with little effort by adjusting in increments of .015mm (.0006") for conductor crimp height and .063mm (.0025") for insulation height
- Independent adjustment rings allow users to quickly adjust the conductor or insulation crimp height without affecting each other
- Directly adapts to most automatic wire processing machines

### SCOPE

Products: Mini-Fit Jr.™ Crimp Terminal 16 AWG with smaller insulation OD's.

Terminal Series No.	Terminal Order No.				Wire Size		Insulation Diameter		Strip Length	
					AWG	mm <sup>2</sup>	mm	In.	mm	In.
5556	39-00-0077	39-00-0118	39-00-0173	39-00-0204	16	1.31	1.80-2.45	.071-.096	3.00-3.50	.118-.138
	39-00-0079	39-00-0141	39-00-0179	39-00-0211						
	39-00-0089	39-00-0157	39-00-0185	39-00-0217						
	39-00-0093	39-00-0167	39-00-0198	39-00-0447						
	39-00-0112									
5558	39-00-0081	39-00-0099	39-00-0147	40-01-0855	16	1.31	1.80-2.45	.071-.096	3.00-3.50	.118-.138
	39-00-0083	39-00-0124	39-00-0223	98-00-0176						
	39-00-0095	39-00-0130	39-00-0449							
44476	44476-3111	44476-3211			16	1.31	1.80-2.45	.071-.096	3.00-3.50	.118-.138
44478	44478-3111	44478-3211			16	1.31	1.80-2.45	.071-.096	3.00-3.50	.118-.138
44485	44485-3211	44485-3311	44485-3411		16	1.31	1.80-2.45	.071-.096	3.00-3.50	.118-.138
45750	45750-3111	45750-3211			16	1.31	2.20-2.45	.087-.096	3.00-3.50	.118-.138
46012	46012-3111	46012-3211			16	1.31	2.20-2.45	.087-.096	3.00-3.50	.118-.138
46018	46018-3541				16	1.31	2.20-2.45	.087-.096	3.00-3.50	.118-.138
46083	46083-3111	46083-3121	46083-3211	46083-3221	16	1.31	2.20-2.45	.087-.096	3.00-3.50	.118-.138
46098	46098-3541				16	1.31	2.20-2.45	.087-.096	3.00-3.50	.118-.138

⚠ This Applicator will crimp the above terminals and wires.  
 However it provides optimum A-620 Class 2 crimps for 16 AWG wire  
 with insulation O.D. 2.20-2.45mm (example UL1007).  
 Applicator 63860-1200 should be used for insulation O.D. 2.45-3.15mm (example UL1015).

### DEFINITION OF TERMS

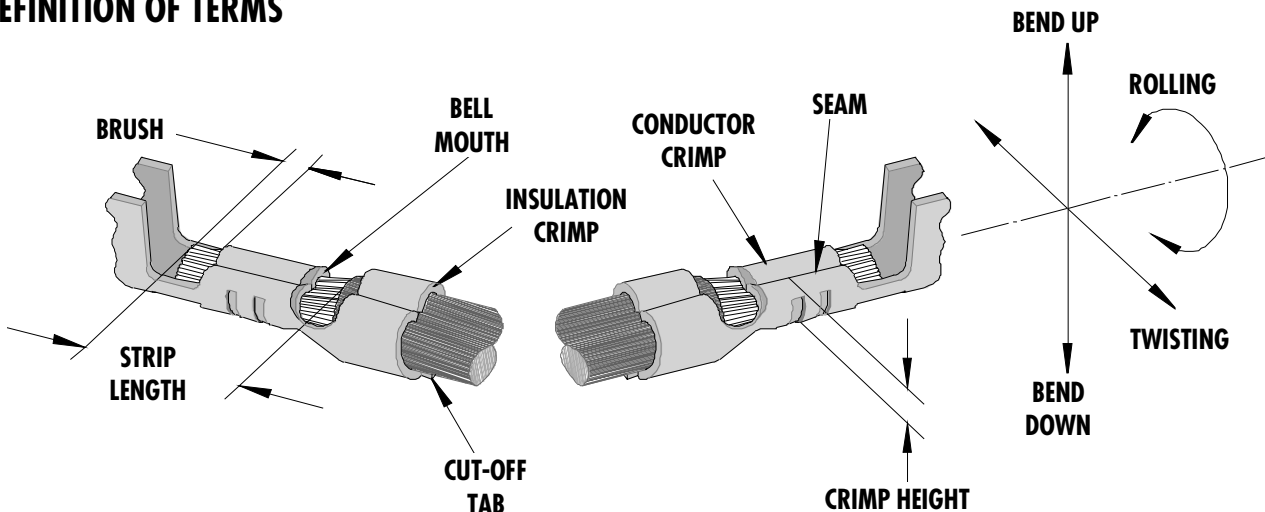

The above terminal drawing is a generic terminal representation. It is not an image of a terminal listed in the scope.

### CRIMP SPECIFICATION

Terminal Series No.	Bell mouth		Cut-off Tab Max.		Conductor Brush	
	mm	In.	mm	In.	mm	In.
5556	0.20-0.50	.008-.020	0.30	.012	0.00-1.00	.000-.039
5558	0.20-0.50	.008-.020	0.30	.012	0.00-1.00	.000-.039
44476	0.20-0.50	.008-.020	0.30	.012	0.00-1.00	.000-.039
44478	0.20-0.50	.008-.020	0.30	.012	0.00-1.00	.000-.039
44485	0.20-0.50	.008-.020	0.30	.012	0.00-1.00	.000-.039
45750	0.20-0.50	.008-.020	0.30	.012	0.00-1.00	.000-.039
46012	0.20-0.50	.008-.020	0.30	.012	0.00-1.00	.000-.039
46018	0.20-0.50	.008-.020	0.30	.012	0.00-1.00	.000-.039
46083	0.20-0.50	.008-.020	0.30	.012	0.00-1.00	.000-.039
46098	0.20-0.50	.008-.020	0.30	.012	0.00-1.00	.000-.039

Terminal Series No.	Bend up	Bend down	Twist	Roll	Punch Width (Ref)			
					Conductor		Insulation	
	Degree		Degree		mm	In.	mm	In.
5556	5	2	5	15	1.90	.075	2.60	.102
5558	5	2	5	15	1.90	.075	2.60	.102
44476	5	2	5	15	1.90	.075	2.60	.102
44478	5	2	5	15	1.90	.075	2.60	.102
44485	5	2	5	15	1.90	.075	2.60	.102
45750	5	2	5	15	1.90	.075	2.60	.102
46012	5	2	5	15	1.90	.075	2.60	.102
46018	5	2	5	15	1.90	.075	2.60	.102
46083	5	2	5	15	1.90	.075	2.60	.102
46098	5	2	5	15	1.90	.075	2.60	.102

**Seam**  
Seam shall not be open  
And no wire allowed out  
of the crimping area

After crimping, the crimp profiles should measure the following:

Terminal Series No.	Wire Size		Conductor				Pull Force Min.	
			Crimp Height		Crimp Width (Ref)			
	AWG	mm <sup>2</sup>	mm	In.	mm	In.	N	Lb.
5556	16	1.31	1.14-1.24	.045-.049	1.97	.078	68.4	15.4
5558	16	1.31	1.14-1.24	.045-.049	1.97	.078	68.4	15.4
44476	16	1.31	1.14-1.24	.045-.049	1.97	.078	68.4	15.4
44478	16	1.31	1.14-1.24	.045-.049	1.97	.078	68.4	15.4
44485	16	1.31	1.14-1.24	.045-.049	1.97	.078	68.4	15.4
45750	16	1.31	1.14-1.24	.045-.049	1.97	.078	68.4	15.4
46012	16	1.31	1.14-1.24	.045-.049	1.97	.078	68.4	15.4
46018	16	1.31	1.14-1.24	.045-.049	1.97	.078	68.4	15.4
46083	16	1.31	1.14-1.24	.045-.049	1.97	.078	68.4	15.4
46098	16	1.31	1.14-1.24	.045-.049	1.97	.078	68.4	15.4

 Tool Qualification Notes:

1. Pull Force should be measured with no influence from the insulation crimp.
2. The above specifications are guidelines to an optimum crimp.

**PARTS LIST**

<b>FineAdjust Applicator 63860-1500</b>				
<b>Item</b>	<b>Order No</b>	<b>Engineering No.</b>	<b>Description</b>	<b>Quantity</b>
<b>Perishable Tooling</b>				
	63860-1570	63860-1570	Tool Kit (All "Y" Items)	REF
1	63444-1909	63444-1909	Conductor Punch	1 Y
2	63445-1943	63445-1943	Conductor Anvil	1 Y
3	63446-2610	63446-2610	Insulation Punch	1 Y
4	63445-2610	63445-2610	Insulation Anvil	1 Y
5	63443-0002	63443-0002	Cut-Off Plunger Front	1 Y
6	63443-0012	63443-0012	Plunger Retainer Front	1 Y
<b>Other Components</b>				
7	11-18-4083	60707-8	Front Cover	1
8	11-24-1067	4996-4	Cut-off Plunger Spring	1
9	11-40-4039	8302-5	Plunger Striker Front	1
10	63443-0009	63443-0009	Scrap Chute Front	1
11	63443-0021	63443-0021	Lower Tooling Key	1
12	63443-2408	63443-2408	Anvil Mount	1
13	63443-4018	63443-4018	Wire Stop	1
14	63443-6003	63443-6003	Rear Cover	1
<b>Frame</b>				
15	63800-4901	63800-4901	Top	1
16	63801-3281	63801-3281	Base	1
17	63801-4650	63801-4650	Track	1
<b>Hardware</b>				
18	N/A	N/A	M3 by 6 Long SHCS	2**
19	N/A	N/A	M4 by 6 Long SHCS	1**
20	N/A	N/A	M4 by 12 Long BHCS	2**
21	N/A	N/A	M4 by 16 Long SHCS	1**
22	N/A	N/A	M4 by 20 Long SHCS	1**
23	N/A	N/A	M4 by 50 Long SHCS	1**
24	N/A	N/A	3MM by 6 Long Roll Pin	1**
25	N/A	N/A	#10-32 by 1/4" Long BHCS	1**
** Available from an industrial supply company such as MSC (1-800-645-7270).				

# Assembly Drawing

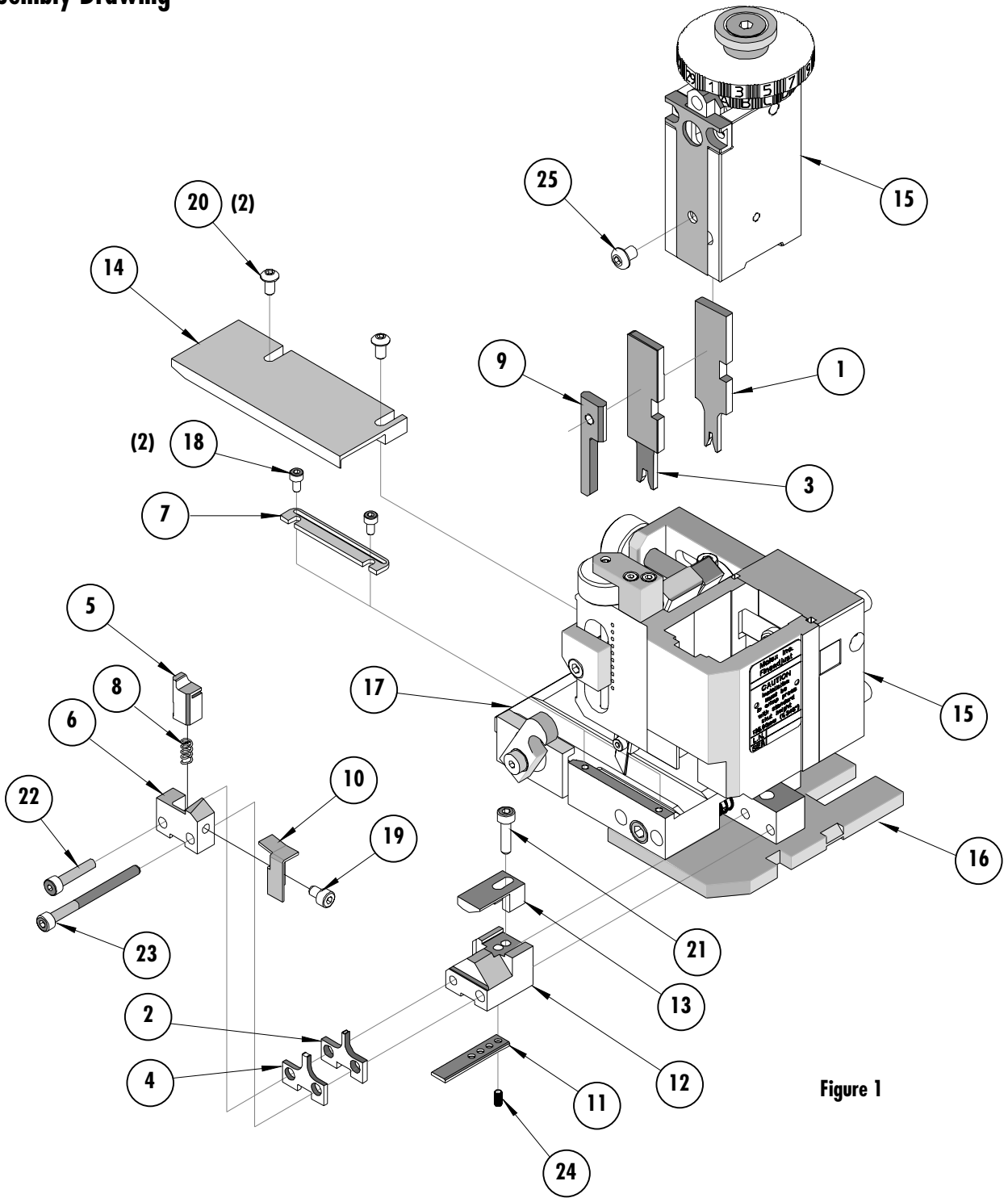

Figure 1

## NOTES

1. Molex recommends an extra perishable tooling kit be maintained at your facility.
2. Verify tooling alignment by manually cycling the press and Applicator before crimping under power. Check that all screws are tight.
3. Slugs, Terminals, Dirt and Oil should be kept clear of work area.
4. Wear safety glasses at all times.
5. For recommended maintenance refer to the FineAdjust Manual.

**CAUTION:** This applicator should only be used in a press with a shut height of 135.80 mm (5.346"). Tooling damage could result at a lower setting.

**CAUTION:** To prevent injury never operate this Applicator without the guards supplied with the press or wire-processing machine in place. Reference the press or wire processing manufacturer's instruction manual.

**CAUTION:** Molex crimp specifications are valid only when used with Molex terminals, applicators and tooling.

**Americas Headquarters**

Lisle, Illinois 60532 U.S.A.  
1-800-78MOLEX  
amerinfo@molex.com

**Far East North Headquarters**

Yamato, Kanagawa, Japan  
81-462-65-2324  
feninfo@molex.com

**Far East South Headquarters**

Jurong, Singapore  
65-6-268-6868  
fesinfo@molex.com

**European Headquarters**

Munich, Germany  
49-89-413092-0  
eurinfo@molex.com

**Corporate Headquarters**

2222 Wellington Ct.  
Lisle, IL 60532 U.S.A.  
630-969-4550  
Fax: 630-969-1352

Visit our Web site at <http://www.molex.com>



Компания «ЭлектроПласт» предлагает заключение долгосрочных отношений при поставках импортных электронных компонентов на взаимовыгодных условиях!

Наши преимущества:

- Оперативные поставки широкого спектра электронных компонентов отечественного и импортного производства напрямую от производителей и с крупнейших мировых складов;
- Поставка более 17-ти миллионов наименований электронных компонентов;
- Поставка сложных, дефицитных, либо снятых с производства позиций;
- Оперативные сроки поставки под заказ (от 5 рабочих дней);
- Экспресс доставка в любую точку России;
- Техническая поддержка проекта, помощь в подборе аналогов, поставка прототипов;
- Система менеджмента качества сертифицирована по Международному стандарту ISO 9001;
- Лицензия ФСБ на осуществление работ с использованием сведений, составляющих государственную тайну;
- Поставка специализированных компонентов (Xilinx, Altera, Analog Devices, Intersil, Interpoint, Microsemi, Aeroflex, Peregrine, Syfer, Eurofarad, Texas Instrument, Miteq, Cobham, E2V, MA-COM, Hittite, Mini-Circuits, General Dynamics и др.);

Помимо этого, одним из направлений компании «ЭлектроПласт» является направление «Источники питания». Мы предлагаем Вам помощь Конструкторского отдела:

- Подбор оптимального решения, техническое обоснование при выборе компонента;
- Подбор аналогов;
- Консультации по применению компонента;
- Поставка образцов и прототипов;
- Техническая поддержка проекта;
- Защита от снятия компонента с производства.



#### Как с нами связаться

**Телефон:** 8 (812) 309 58 32 (многоканальный)

**Факс:** 8 (812) 320-02-42

**Электронная почта:** [org@eplast1.ru](mailto:org@eplast1.ru)

**Адрес:** 198099, г. Санкт-Петербург, ул. Калинина, дом 2, корпус 4, литера А.