

**PLEASE CHECK WWW.MOLEX.COM FOR LATEST PART INFORMATION**

**Part Number:** **0458021223**  
**Status:** **Active**  
**Description:** 1.20mm (.047") x 2.00mm (.079") Pitch HD Mezz™ Receptacle, 299 Circuits, 18.00mm (.709") Unmated Height, 23 Rows, Lead Free

**Documents:**

[3D Model](#) [Product Specification PS-45802-001 \(PDF\)](#)  
[Drawing \(PDF\)](#) [RoHS Certificate of Compliance \(PDF\)](#)

**Agency Certification**

CSA LR19980  
 UL E29179

**General**

Product Family PCB Receptacles  
 Series [45802](#)  
 Application Board-to-Board  
 Comments 1.20mm (.047") Pitch Pin-to-Pin and 2.00mm (.079") Pitch Row-to-Row  
 Product Name Mezzanine

**Physical**

Circuits (Loaded) 299  
 Circuits (maximum) 299  
 Color - Resin Black  
 Durability (mating cycles max) 100  
 Flammability 94V-0  
 Glow-Wire Compliant No  
 Guide to Mating Part No  
 Keying to Mating Part None  
 Lock to Mating Part Yes  
 Material - Metal High Performance Alloy (HPA)  
 Material - Plating Mating Gold  
 Material - Plating Termination Tin  
 Material - Resin High Temperature Thermoplastic  
 Number of Rows 23  
 Orientation Vertical  
 PC Tail Length (in) 0.000 In  
 PC Tail Length (mm) 0.00 mm  
 PCB Locator Yes  
 PCB Retention Yes  
 PCB Thickness Recommended (in) 0.000 In  
 PCB Thickness Recommended (mm) 0.00 mm  
 Packaging Type Tray  
 Pitch - Mating Interface (in) 0.079 In  
 Pitch - Mating Interface (mm) 2.00 mm  
 Pitch - Term. Interface (in) 0.079 In  
 Pitch - Term. Interface (mm) 2.00 mm  
 Plating min: Mating (µin) 30  
 Plating min: Mating (µm) 0.75  
 Plating min: Termination (µin) 100  
 Plating min: Termination (µm) 2.5  
 Polarized to Mating Part Yes  
 Polarized to PCB Yes  
 Robotic Placement Vacuum Pick-Up Tape  
 Stackable No

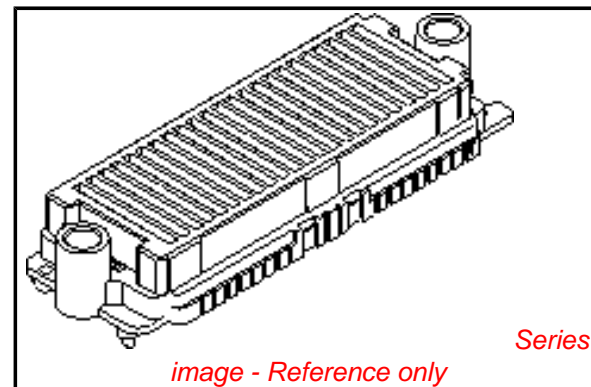

*image - Reference only*

**EU RoHS**

**ELV and RoHS Compliant**  
**REACH SVHC**  
 Not Reviewed  
**Halogen-Free Status**  
**Not Reviewed**

**China RoHS**



**Need more information on product environmental compliance?**

Email [productcompliance@molex.com](mailto:productcompliance@molex.com)  
 For a multiple part number RoHS Certificate of Compliance, [click here](#)

Please visit the [Contact Us](#) section for any non-product compliance questions.

**Search Parts in this Series**

[45802Series](#)

**Mates With**

[45830 HD Mezz™ Plug](#)

Surface Mount Compatible (SMC)	Yes
Temperature Range - Operating	-55°C to +105°C
Termination Interface: Style	Surface Mount

### **Electrical**

Current - Maximum per Contact	2A
Grounding to PCB	No
Voltage - Maximum	250V AC

### **Solder Process Data**

Duration at Max. Process Temperature (seconds)	20
Lead-free Process Capability	Reflow Capable (SMT only)
Max. Cycles at Max. Process Temperature	2
Process Temperature max. C	260

### **Material Info**

#### **Reference - Drawing Numbers**

Product Specification	PS-45802-001
Sales Drawing	SD-45802-001

This document was generated on 04/14/2010

**PLEASE CHECK [WWW.MOLEX.COM](http://WWW.MOLEX.COM) FOR LATEST PART INFORMATION**

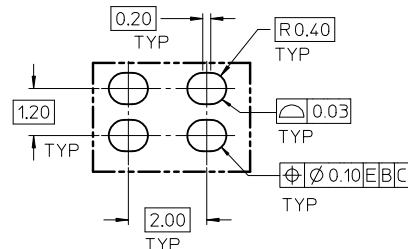
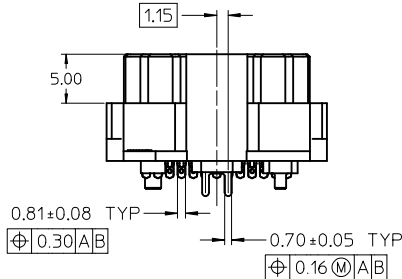
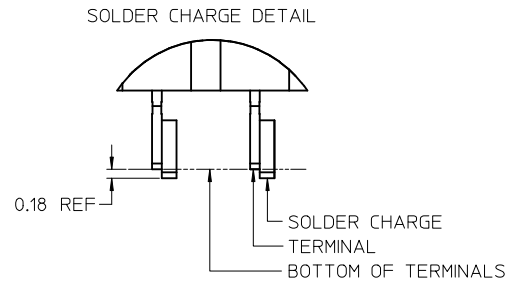
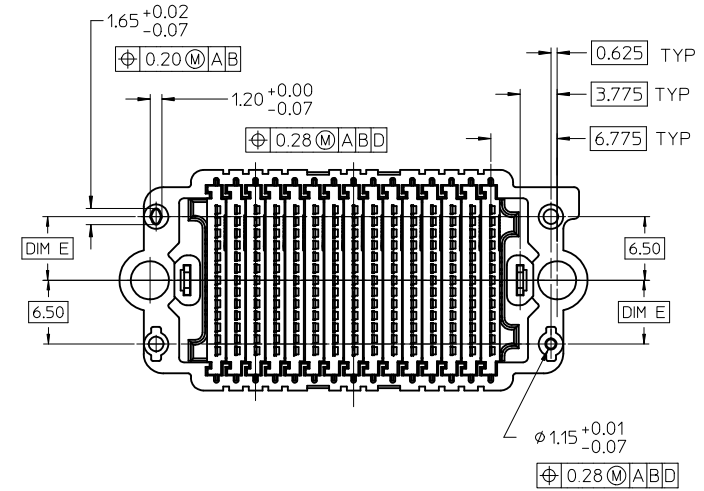
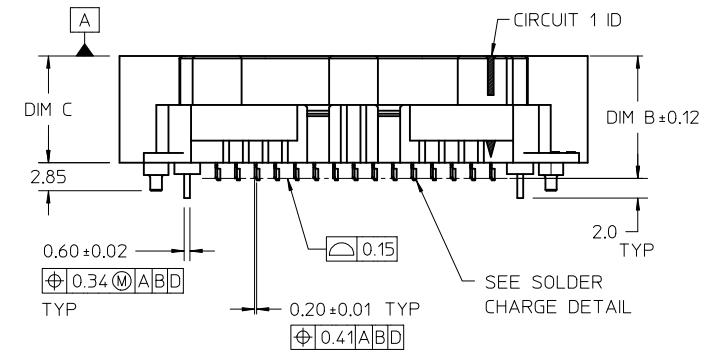
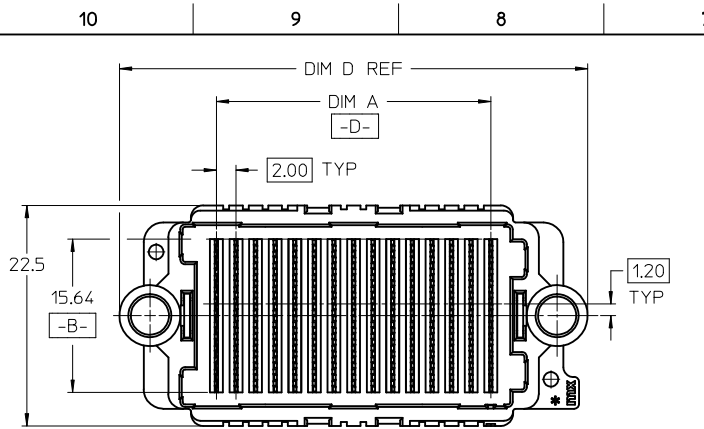

- NOTES:
- HOUSING MATERIAL: LCP, GLASS FILLED, UL 94V-0, BLACK  
CONTACT MATERIAL: HIGH PERFORMANCE ALLOY  
SOLDER NAIL MATL: STAINLESS STEEL  
SOLDER CHARGE MATL: SEE CHART
  - FINISH: SELECT GOLD 30 M.I. MIN IN CONTACT AREA  
SELECT TIN: 100 M.I. MIN IN PCB TAIL  
BOTH OVER NICKEL
  - PRODUCT SPECIFICATION: PS-45802-001
  - COSMETIC SPECIFICATION, PS-45499-002 CLASS B
  - PACKAGING SPECIFICATION: PK-45802-001
  - DATUM -D- IS THE CENTERLINE OF THE 2 END SLOTS. END SLOT CENTERLINES ARE ESTABLISHED USING 2 MEASUREMENTS FOR EACH SLOT TAKEN 7.20 EITHER SIDE OF DATUM -B-.
  - THERE ARE 13 CKTS PER ROW

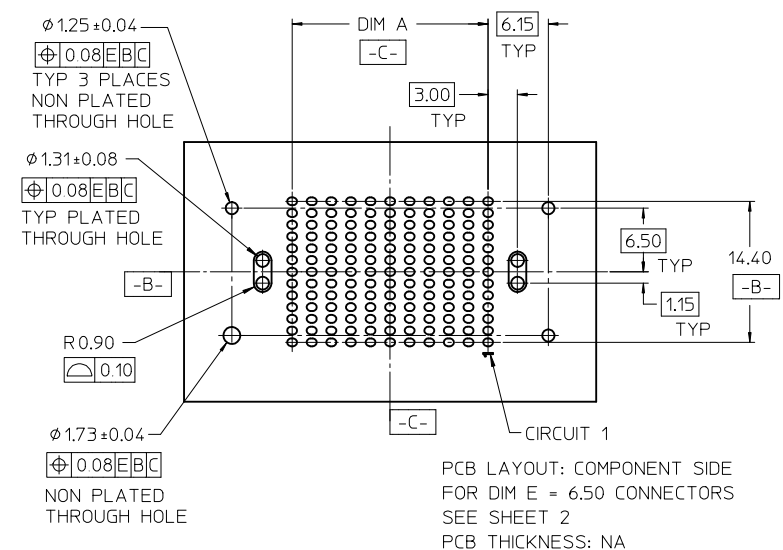

UPDATE EC NO: UCP2010-2574 DR: MNSAMIEC 2010/05/05 CHKD: PELOZA 05/02/07 APPR: JCOMERCI 2010/05/07	QUALITY SYMBOLS	GENERAL TOLERANCES (UNLESS SPECIFIED)	DIMENSION STYLE MM ONLY	SCALE 2:1	DESIGN UNITS METRIC	THIRD ANGLE PROJECTION	
	REV	DESCRIPTION	mm	INCH	DRAWN BY PELOZA	DATE 05/02/04	HIGH DENSITY MEZZANINE RECEPTACLE ASSEMBLY  <b>MOLEX INCORPORATED</b> SD-45802-001 SHEET NO. 1 OF 3
			4 PLACES ± --- ± ---		CHECKED BY PELOZA	DATE 05/02/07	
			3 PLACES ± 0.050 ± ---		APPROVED BY JCOMERCI	DATE 2009/12/23	
D2		ANGULAR ± 1/2°	MATERIAL NO.	SEE CHART	DOCUMENT NO.		
DRAFT WHERE APPLICABLE MUST REMAIN WITHIN DIMENSIONS			SIZE B	THIS DRAWING CONTAINS INFORMATION THAT IS PROPRIETARY TO MOLEX INCORPORATED AND SHOULD NOT BE USED WITHOUT WRITTEN PERMISSION			

		10	9	8	7	6	5	4	3	2	1		
TIN / LEAD PARTS LEAD CODE = "0"	STACK HEIGHT:		8 mm	9 mm	10 mm	11 mm	12 mm	13 mm	14 mm	15 mm	17 mm	18 mm	
	DIM B:		10.51	11.51	12.51	13.51	14.51	15.51	16.51	17.51	19.51	20.51	
	DIM C:		8.90	9.90	10.90	11.90	12.90	13.90	14.90	15.90	17.90	18.90	
	ROWS	DIM A	DIM D	MATERIAL No	MATERIAL No	MATERIAL No	MATERIAL No	MATERIAL No	MATERIAL No	MATERIAL No	MATERIAL No	MATERIAL No	
	07	12.00	31.89	45802-0007	45802-3007	45802-2007	45802-8007	45802-4007	45802-9007	45802-6007	45802-7007	45802-5007	45802-1007
	09	16.00	35.89	45802-0009	45802-3009	45802-2009	45802-8009	45802-4009	45802-9009	45802-6009	45802-7009	45802-5009	45802-1009
	11	20.00	39.89	45802-0011	45802-3011	45802-2011	45802-8011	45802-4011	45802-9011	45802-6011	45802-7011	45802-5011	45802-1011
	13	24.00	43.89	45802-0013	45802-3013	45802-2013	45802-8013	45802-4013	45802-9013	45802-6013	45802-7013	45802-5013	45802-1013
	15	28.00	47.89	45802-0015	45802-3015	45802-2015	45802-8015	45802-4015	45802-9015	45802-6015	45802-7015	45802-5015	45802-1015
	17	32.00	51.89	45802-0017	45802-3017	45802-2017	45802-8017	45802-4017	45802-9017	45802-6017	45802-7017	45802-5017	45802-1017
	19	36.00	55.89	45802-0019	45802-3019	45802-2019	45802-8019	45802-4019	45802-9019	45802-6019	45802-7019	45802-5019	45802-1019
	21	40.00	59.89	45802-0021	45802-3021	45802-2021	45802-8021	45802-4021	45802-9021	45802-6021	45802-7021	45802-5021	45802-1021
	23	44.00	63.89	45802-0123	45802-3023	45802-2023	45802-8023	45802-4023	45802-9023	45802-6023	45802-7023	45802-5023	45802-1123
25	48.00	67.89	45802-0025	45802-3025	45802-2025	45802-8025	45802-4025	45802-9025	45802-6025	45802-7025	45802-5025	45802-1025	
27	52.00	71.89	45802-0027	45802-3027	45802-2027	45802-8027	45802-4027	45802-9027	45802-6027	45802-7027	45802-5027	45802-1027	

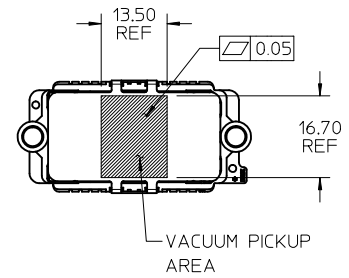

		10	9	8	7	6	5	4	3	2	1		
TIN PARTS LEAD CODE = "2"	STACK HEIGHT:		8 mm	9 mm	10 mm	11 mm	12 mm	13 mm	14 mm	15 mm	17 mm	18 mm	
	DIM B:		10.51	11.51	12.51	13.51	14.51	15.51	16.51	17.51	19.51	20.51	
	DIM C:		8.90	9.90	10.90	11.90	12.90	13.90	14.90	15.90	17.90	18.90	
	ROWS	DIM A	DIM D	MATERIAL No	MATERIAL No	MATERIAL No	MATERIAL No	MATERIAL No	MATERIAL No	MATERIAL No	MATERIAL No	MATERIAL No	
	07	12.00	31.89	45802-0207	45802-3207	45802-2207	45802-8207	45802-4207	45802-9207	45802-6207	45802-7207	45802-5207	45802-1207
	09	16.00	35.89	45802-0209	45802-3209	45802-2209	45802-8209	45802-4209	45802-9209	45802-6209	45802-7209	45802-5209	45802-1209
	11	20.00	39.89	45802-0311	45802-3211	45802-2211	45802-8211	45802-4211	45802-9211	45802-6211	45802-7211	45802-5211	45802-1211
	13	24.00	43.89	45802-0213	45802-3213	45802-2213	45802-8213	45802-4213	45802-9213	45802-6213	45802-7213	45802-5213	45802-1213
	15	28.00	47.89	45802-0215	45802-3215	45802-2215	45802-8215	45802-4215	45802-9215	45802-6215	45802-7215	45802-5215	45802-1215
	17	32.00	51.89	45802-0217	45802-3217	45802-2217	45802-8217	45802-4217	45802-9217	45802-6217	45802-7217	45802-5217	45802-1217
	19	36.00	55.89	45802-0219	45802-3219	45802-2219	45802-8219	45802-4219	45802-9219	45802-6219	45802-7219	45802-5219	45802-1219
	21	40.00	59.89	45802-0221	45802-3221	45802-2221	45802-8221	45802-4221	45802-9221	45802-6221	45802-7221	45802-5221	45802-1221
	23	44.00	63.89	45802-0223	45802-3223	45802-2223	45802-8223	45802-4223	45802-9223	45802-6223	45802-7223	45802-5223	45802-1223
25	48.00	67.89	45802-0225	45802-3225	45802-2225	45802-8225	45802-4225	45802-9225	45802-6225	45802-7225	45802-5225	45802-1225	
27	52.00	71.89	45802-0227	45802-3227	45802-2227	45802-8227	45802-4227	45802-9227	45802-6227	45802-7227	45802-5227	45802-1227	

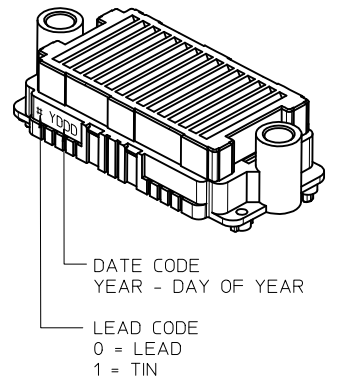

DIM E = 6.50 ON ALL PART NO.  
ON THIS SHEET

SEE SHEET 1  
EC NO: UCP2010-2574  
DRAWN:KSM/IEC 2010/05/05  
CHKD:PELOZA 05/02/07  
APPR:JCOMERCI 2010/05/07  
REV DESCRIPTION

GENERAL TOLERANCES (UNLESS SPECIFIED)  
4 PLACES ± --- ± ---  
3 PLACES ± 0.050 ± ---  
2 PLACES ± 0.15 ± ---  
1 PLACE ± 0.3 ± ---  
ANGULAR ± 1/2°  
DRAFT WHERE APPLICABLE MUST REMAIN WITHIN DIMENSIONS

DIMENSION STYLE  
MM ONLY  
DRAWN BY DATE  
PELOZA 05/02/04  
CHECKED BY DATE  
PELOZA 05/02/07  
APPROVED BY DATE  
JCOMERCI 2009/12/23  
MATERIAL NO.  
SEE CHART

SCALE 1:1  
DESIGN UNITS METRIC  
THIRD ANGLE PROJECTION  
TITLE  
HIGH DENSITY MEZZANINE RECEPTACLE ASSEMBLY  
MOLEX INCORPORATED  
DOCUMENT NO. SD-45802-001  
SHEET NO. 2 OF 3  
THIS DRAWING CONTAINS INFORMATION THAT IS PROPRIETARY TO MOLEX INCORPORATED AND SHOULD NOT BE USED WITHOUT WRITTEN PERMISSION

DIM E = 3.77 ON ALL PART NO.  
ON THIS SHEET

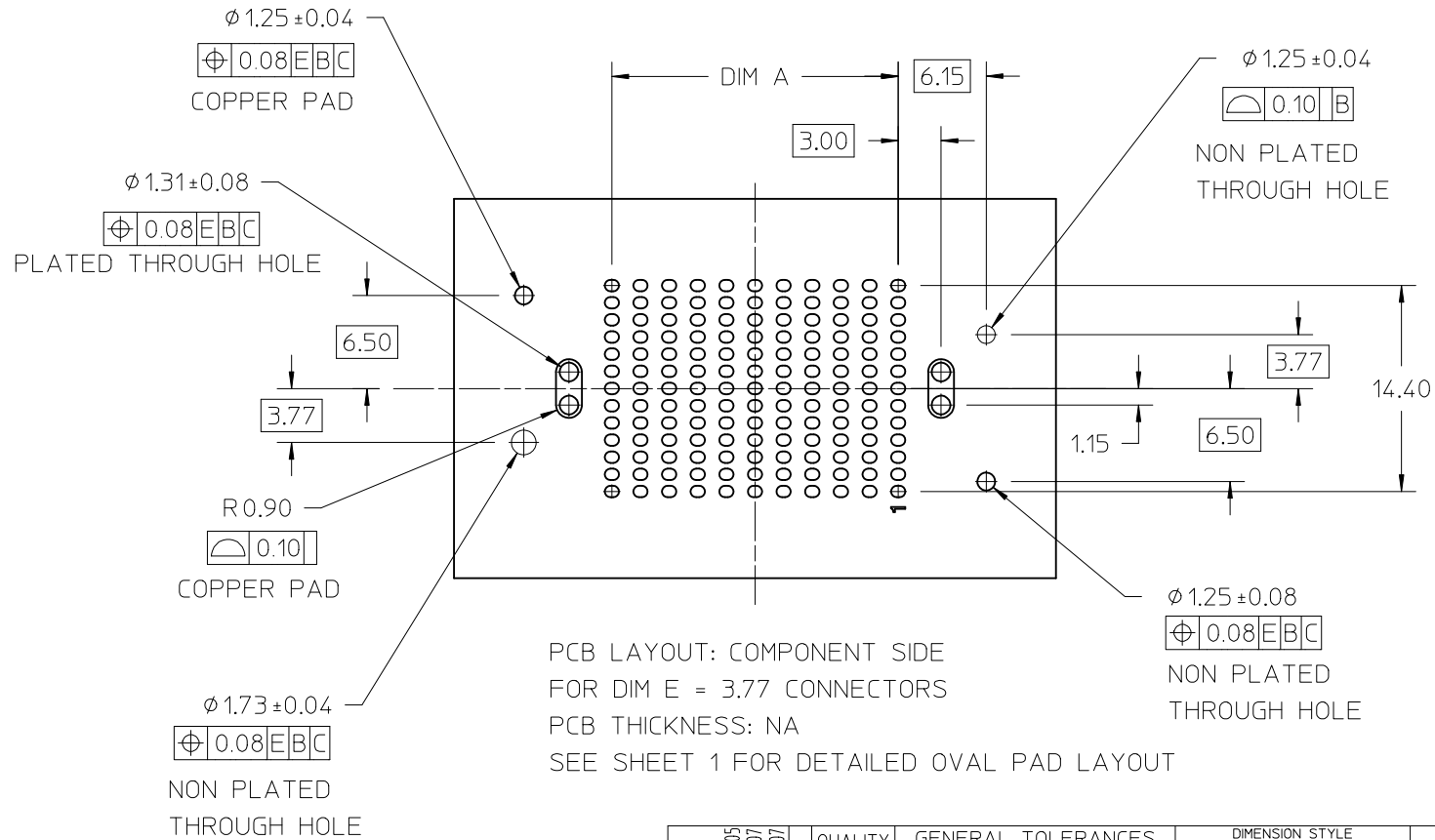

PCB LAYOUT: COMPONENT SIDE  
FOR DIM E = 3.77 CONNECTORS  
PCB THICKNESS: NA  
SEE SHEET 1 FOR DETAILED OVAL PAD LAYOUT

LEAD CODE = "0"			
	STACK HEIGHT:	18 mm	
	DIM B:	20.51	
	DIM C:	18.90	
ROWS	DIM A	DIM D	MATERIAL No
07	12.00	31.89	45802-1507
09	16.00	35.89	45802-1509
11	20.00	39.89	45802-1511
13	24.00	43.89	45802-1513
15	28.00	47.89	45802-1515
17	32.00	51.89	45802-1517
19	36.00	55.89	45802-1519
21	40.00	59.89	45802-1521
23	44.00	63.89	45802-1523
25	48.00	67.89	45802-1525
27	52.00	71.89	45802-1527

LEAD CODE = "2"			
	STACK HEIGHT:	18 mm	
	DIM B:	20.51	
	DIM C:	18.90	
ROWS	DIM A	DIM D	MATERIAL No
07	12.00	31.89	45802-1607
09	16.00	35.89	45802-1609
11	20.00	39.89	45802-1611
13	24.00	43.89	45802-1613
15	28.00	47.89	45802-1615
17	32.00	51.89	45802-1617
19	36.00	55.89	45802-1619
21	40.00	59.89	45802-1621
23	44.00	63.89	45802-1623
25	48.00	67.89	45802-1625
27	52.00	71.89	45802-1627

<b>ENTER DESCRIPTION</b> EC NO: UCP2010-2574 DRWKSAMIEC 2010/05/05 CHKD:PELOZA 05/02/07 APPR:JCOMERCI 2010/05/07 <b>D2</b>	<b>QUALITY SYMBOLS</b> ▽/0 ▽/0 ▽/0	<b>GENERAL TOLERANCES (UNLESS SPECIFIED)</b>		<b>DIMENSION STYLE</b> <b>MM ONLY</b>		<b>SCALE</b> 3:1	<b>DESIGN UNITS</b> METRIC	THIRD ANGLE PROJECTION	
		mm	INCH	DRAWN BY	DATE	<b>TITLE</b> HIGH DENSITY MEZZANINE RECEPTACLE ASSEMBLY			
		4 PLACES ± ---	± ---	PELOZA	05/02/04				
		3 PLACES ± 0.050	± ---	CHECKED BY	DATE	<b>MOLEX INCORPORATED</b>			
2 PLACES ± 0.15	± ---	PELOZA	05/02/07						
1 PLACE ± 0.3	± ---	APPROVED BY	DATE	<b>SD-45802-001</b>					
ANGULAR ±1/2°		JCOMERCI	2009/12/23						
DRAFT WHERE APPLICABLE MUST REMAIN WITHIN DIMENSIONS		MATERIAL NO.		SEE CHART		DOCUMENT NO.		SHEET NO.	
		SIZE B		THIS DRAWING CONTAINS INFORMATION THAT IS PROPRIETARY TO MOLEX INCORPORATED AND SHOULD NOT BE USED WITHOUT WRITTEN PERMISSION				3 OF 3	



Компания «ЭлектроПласт» предлагает заключение долгосрочных отношений при поставках импортных электронных компонентов на взаимовыгодных условиях!

Наши преимущества:

- Оперативные поставки широкого спектра электронных компонентов отечественного и импортного производства напрямую от производителей и с крупнейших мировых складов;
- Поставка более 17-ти миллионов наименований электронных компонентов;
- Поставка сложных, дефицитных, либо снятых с производства позиций;
- Оперативные сроки поставки под заказ (от 5 рабочих дней);
- Экспресс доставка в любую точку России;
- Техническая поддержка проекта, помощь в подборе аналогов, поставка прототипов;
- Система менеджмента качества сертифицирована по Международному стандарту ISO 9001;
- Лицензия ФСБ на осуществление работ с использованием сведений, составляющих государственную тайну;
- Поставка специализированных компонентов (Xilinx, Altera, Analog Devices, Intersil, Interpoint, Microsemi, Aeroflex, Peregrine, Syfer, Eurofarad, Texas Instrument, Miteq, Cobham, E2V, MA-COM, Hittite, Mini-Circuits, General Dynamics и др.);

Помимо этого, одним из направлений компании «ЭлектроПласт» является направление «Источники питания». Мы предлагаем Вам помощь Конструкторского отдела:

- Подбор оптимального решения, техническое обоснование при выборе компонента;
- Подбор аналогов;
- Консультации по применению компонента;
- Поставка образцов и прототипов;
- Техническая поддержка проекта;
- Защита от снятия компонента с производства.



#### Как с нами связаться

**Телефон:** 8 (812) 309 58 32 (многоканальный)

**Факс:** 8 (812) 320-02-42

**Электронная почта:** [org@eplast1.ru](mailto:org@eplast1.ru)

**Адрес:** 198099, г. Санкт-Петербург, ул. Калинина, дом 2, корпус 4, литера А.