

# One-Time Programmable, Linear-Taper Digital Potentiometers

## General Description

The MAX5427/MAX5428/MAX5429 linear-taper digital potentiometers function as mechanical potentiometers, but replace the mechanics with a simple 2-wire digital interface. These digital potentiometers are unique in that they have an optional one-time programmable feature that either sets the wiper's power-on reset (POR) position to a user-defined value, or the wiper can be set and the interface disabled to prevent further adjustment.

The MAX5427 has an end-to-end resistance of 100k $\Omega$ , the MAX5428 a resistance of 50k $\Omega$ , and the MAX5429 a resistance of 10k $\Omega$ . All these devices have 32 wiper positions, operate from a single 2.7V to 5.5V supply, and use less than 1.5 $\mu$ A (max) static supply current.

The MAX5427/MAX5428/MAX5429 are available in 8-pin thin QFN and  $\mu$ MAX<sup>®</sup> packages. Each device is guaranteed over the extended temperature range of -40°C to +85°C.

## Applications

Mechanical Potentiometer Replacement  
Products Using One-Time Factory Calibration

## Pin Configurations



$\mu$ Max is a registered trademark of Maxim Integrated Products, Inc.

## Features

- ◆ Wiper Position Stored After One-Time Fuse Programming
- ◆ User-Defined Power-On Reset Position
- ◆ 35ppm/°C End-to-End Temperature Coefficient and 5ppm/°C Ratiometric Temperature Coefficient
- ◆ 32 Tap Positions
- ◆ Tiny 8-Pin Thin QFN and  $\mu$ MAX Packages
- ◆ Ultra-Low 1.5 $\mu$ A (max) Static Supply Current
- ◆ 2.7V to 5.5V Single-Supply Operation
- ◆ Wiper Position Programmed Through Simple 2-Wire Serial Interface
- ◆ 10k $\Omega$ , 50k $\Omega$ , and 100k $\Omega$  End-to-End Resistances

## Ordering Information

PART	TEMP RANGE	PIN-PACKAGE	R (k $\Omega$ )
MAX5427EUA	-40°C to +85°C	8 $\mu$ MAX	100
MAX5427ETA	-40°C to +85°C	8 Thin QFN-EP*	100
MAX5428EUA	-40°C to +85°C	8 $\mu$ MAX	50
MAX5428ETA	-40°C to +85°C	8 Thin QFN-EP*	50
MAX5429EUA	-40°C to +85°C	8 $\mu$ MAX	10
MAX5429ETA	-40°C to +85°C	8 Thin QFN-EP*	10

\*EP = Exposed paddle.

## Functional Block Diagram

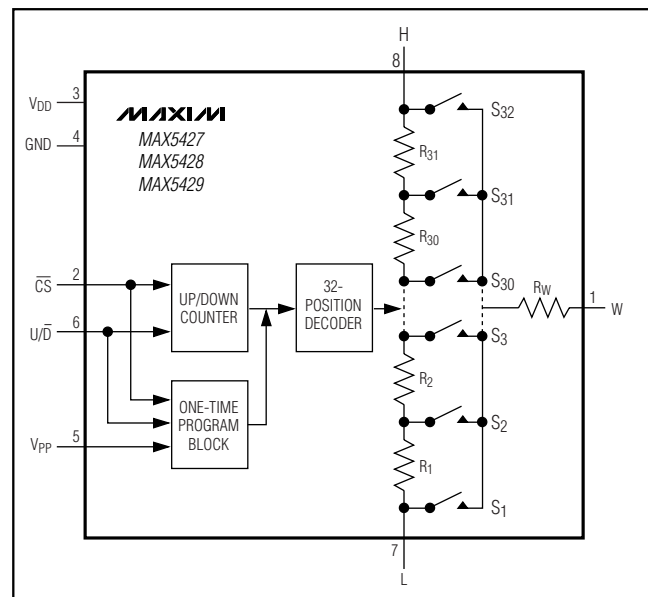

# One-Time Programmable, Linear-Taper Digital Potentiometers

## ABSOLUTE MAXIMUM RATINGS

V <sub>DD</sub> to GND	-0.3V to +6.0V
V <sub>PP</sub> to GND	-0.3V to +12.0V
All Other Pins to GND	-0.3V to (V <sub>DD</sub> + 0.3V)
Input and Output Latchup Immunity	±200mA
Maximum Continuous Current into H, L, and W	
MAX5427	±1.5mA
MAX5428	±1.5mA
MAX5429	±2.0mA

Continuous Power Dissipation (T <sub>A</sub> = +70°C)	
8-Pin $\mu$ MAX (derate 4.5mW/°C above +70°C)	362mW
8-Pin QFN-EP (derate 24.4mW/°C above +70°C)	1951mW
Operating Temperature Range	-40°C to +85°C
Junction Temperature	+150°C
Storage Temperature Range	-65°C to +150°C
Lead Temperature (soldering, 10s)	+300°C

Stresses beyond those listed under "Absolute Maximum Ratings" may cause permanent damage to the device. These are stress ratings only, and functional operation of the device at these or any other conditions beyond those indicated in the operational sections of the specifications is not implied. Exposure to absolute maximum rating conditions for extended periods may affect device reliability.

## ELECTRICAL CHARACTERISTICS

(V<sub>DD</sub> = 2.7V to 5.5V, V<sub>PP</sub> = GND, V<sub>H</sub> = V<sub>DD</sub>, V<sub>L</sub> = GND, T<sub>A</sub> = -40°C to +85°C, unless otherwise noted. Typical values are at V<sub>DD</sub> = 5.0V, T<sub>A</sub> = +25°C, unless otherwise noted.) (Note 1)

PARAMETER	SYMBOL	CONDITIONS	MIN	TYP	MAX	UNITS
<b>DC PERFORMANCE</b>						
Resolution			32			Taps
End-to-End Resistance		MAX5427	75	100	125	k $\Omega$
		MAX5428	37.5	50	62.5	
		MAX5429	7.5	10	12.5	
End-to-End Resistance Tempco	TC <sub>R</sub>			35		ppm/°C
Ratiometric Resistance Tempco		MAX5427/MAX5428		5		ppm/°C
		MAX5429		10		
Integral Nonlinearity	INL	Potentiometer configuration, no load, Figure 1			±1	LSB
Differential Nonlinearity	DNL	Potentiometer configuration, no load, Figure 1			±1	LSB
Full-Scale Error		Potentiometer configuration, no load, Figure 1			-0.5	LSB
Zero-Scale Error		Potentiometer configuration, no load, Figure 1			+0.5	LSB
Wiper Resistance	R <sub>W</sub>	MAX5427 I <sub>W</sub> = 20 $\mu$ A; MAX5428 I <sub>W</sub> = 40 $\mu$ A; MAX5429 I <sub>W</sub> = 200 $\mu$ A		100	240	$\Omega$
<b>DIGITAL INPUTS (<math>\overline{CS}</math>, U/<math>\overline{D}</math>)</b>						
Input High Voltage	V <sub>IH</sub>		0.7 x V <sub>DD</sub>			V
Input Low Voltage	V <sub>IL</sub>				0.3 x V <sub>DD</sub>	V
Input Current	I <sub>IN</sub>			±0.1	±1	$\mu$ A
Input Capacitance	C <sub>IN</sub>			5		pF
<b>TIMING CHARACTERISTICS (Note 2)</b>						
U/ $\overline{D}$ Mode to $\overline{CS}$ Setup	t <sub>CU</sub>	Figures 2, 3	50			ns
$\overline{CS}$ Hold to U/ $\overline{D}$ Mode	t <sub>CI</sub>	Figures 2, 3	50			ns
U/ $\overline{D}$ Step Hold to $\overline{CS}$	t <sub>IC</sub>	Figures 2, 3	0			ns
U/ $\overline{D}$ Step Low Time	t <sub>IL</sub>	Figures 2, 3	100			ns

# One-Time Programmable, Linear-Taper Digital Potentiometers

MAX5427/MAX5428/MAX5429

## ELECTRICAL CHARACTERISTICS (continued)

( $V_{DD} = 2.7V$  to  $5.5V$ ,  $V_{PP} = GND$ ,  $V_H = V_{DD}$ ,  $V_L = GND$ ,  $T_A = -40^{\circ}C$  to  $+85^{\circ}C$ , unless otherwise noted. Typical values are at  $V_{DD} = 5.0V$ ,  $T_A = +25^{\circ}C$ , unless otherwise noted.) (Note 1)

PARAMETER	SYMBOL	CONDITIONS	MIN	TYP	MAX	UNITS
U/D Step High Time	$t_{IH}$	Figures 2, 3	100			ns
Wiper Switching Time	$t_{IW}$	$C_L = 0pF$ , Figures 2, 3		100		ns
$V_{PP}$ Rising Edge to $\overline{CS}$ Falling Edge	$t_{PC}$	Figure 4	1			ms
$\overline{CS}$ Falling Edge to $V_{PP}$ Falling Edge	$t_{CP}$	Figure 4	5			ms
$\overline{CS}$ Step Low Time	$t_{CL}$	Figure 4	5			ms
$\overline{CS}$ Step High Time	$t_{CH}$	Figure 4	5			ms
$V_{PP}$ Falling Edge to $\overline{CS}$ Rising Edge	$t_{PH}$	Figure 4	1			ms
U/D Frequency	$f_{U/\overline{D}MAX}$				5	MHz
Power-Up Time	$t_{UP}$	(Note 3)			1	ms
Output Settling Time	$t_{SETTLE}$	100k $\Omega$ variable resistor configuration, $C_L = 10pF$ , Figure 1		1		$\mu s$
		100k $\Omega$ potentiometer configuration, $C_L = 10pF$ , Figure 1		0.25		
<b>POWER SUPPLY</b>						
Supply Voltage	$V_{DD}$		2.7		5.5	V
Static Supply Current	$I_{DD}$	(Note 4)			1.5	$\mu A$
Programming Voltage	$V_{PP}$	$T_A < +50^{\circ}C$	10.45		11.55	V
		$T_A \geq +50^{\circ}C$	11		11.55	
Programming Current	$I_{PP}$	$V_{PP} = 11V$		5		mA

**Note 1:** All devices are production tested at  $T_A = +25^{\circ}C$  and are guaranteed by design for  $T_A = -40^{\circ}C$  to  $+85^{\circ}C$ .

**Note 2:** Digital timing is guaranteed by design, not production tested.

**Note 3:** Power-up time is the period of time from when the power supply is applied until the serial interface is ready for writing.

**Note 4:** Digital inputs  $\overline{CS}$  and  $U/\overline{D}$  are connected to GND or  $V_{DD}$ .



Figure 1. Potentiometer/Variable-Resistor Configuration

# One-Time Programmable, Linear-Taper Digital Potentiometers

## Typical Operating Characteristics

( $V_{DD} = 5.0V$ ,  $T_A = +25^\circ C$ , unless otherwise noted.)



# One-Time Programmable, Linear-Taper Digital Potentiometers

## Typical Operating Characteristics (continued)

( $V_{DD} = 5.0V$ ,  $T_A = +25^\circ C$ , unless otherwise noted.)



## Pin Description

PIN	NAME	FUNCTION
1	W	Wiper Connection
2	$\overline{CS}$	Chip-Select Input. A high-to-low $\overline{CS}$ transition determines the mode: increment if $U/\overline{D}$ is high, or decrement if $U/\overline{D}$ is low. $\overline{CS}$ is also used for one-time programming (see the <i>One-Time Programming</i> section).
3	$V_{DD}$	Power-Supply Voltage
4	GND	Ground
5	$V_{PP}$	Programming Voltage for One-Time Programming. Connect $V_{PP}$ to 10V supply when one-time programming the device. For normal operation, connect to ground or let float.
6	$U/\overline{D}$	Up/Down Control Input. With $\overline{CS}$ low, a low-to-high transition increments or decrements the wiper position.
7	L	Low Terminal of Resistor
8	H	High Terminal of Resistor

## Detailed Description

The MAX5427/MAX5428/MAX5429 are 100k $\Omega$ /50k $\Omega$ /10k $\Omega$  (end-to-end resistance) digitally controlled potentiometers. They have 32 tap positions that are accessible to the wiper along the resistor array between H and L.

The wiper (W) position is adjusted sequentially through the tap positions using a simple 2-wire interface. These digital potentiometers have an optional one-time programmable feature that sets the POR position of the wiper. The 2-wire interface can then be disabled, permanently preventing unwanted adjustment.

## Digital Interface Operation

The MAX5427/MAX5428/MAX5429 have two modes of operation when the serial interface is active: increment

mode and decrement mode. The serial interface is only active when  $\overline{CS}$  is low.

The  $\overline{CS}$  and  $U/\overline{D}$  inputs control the position of the wiper along the resistor array. When  $\overline{CS}$  transitions from high to low, the part goes into increment mode if  $U/\overline{D}$  is high (Figure 2), and into decrement mode if  $U/\overline{D}$  is low (Figure 3). Once the mode is set, the device remains in that mode until  $\overline{CS}$  goes high. A low-to-high transition at the  $U/\overline{D}$  increments or decrements the wiper position depending on the current mode.

When the  $\overline{CS}$  input transitions to high (when serial interface is inactive) and  $U/\overline{D}$  is low, the wiper increments or decrements one position in accordance with the state of  $U/\overline{D}$  when  $\overline{CS}$  went low. If  $U/\overline{D}$  is high when  $\overline{CS}$  transitions to high, the wiper remains in the same position.

MAX5427/MAX5428/MAX5429

# One-Time Programmable, Linear-Taper Digital Potentiometers



Figure 2. Increment Mode Serial Interface Timing Diagram



Figure 3. Decrement Mode Serial Interface Timing Diagram

The value of the counter is then stored and the wiper position is maintained.

The wiper performs a make-before-break transition, ensuring that there is never an open circuit during a transition from one resistor tap to another. When the wiper is at either end (max/min) of the resistor array, additional transitions in the direction of the endpoint do not change the counter value (the counter does not wrap around).

### One-Time Programming

The factory-set default position of the wiper on power-up is tap 16. However, the power-up position can be changed once using the one-time programming feature. After the wiper is moved to the desired position, the programming sequence is initiated by setting  $U/\bar{D}$  high, applying 11V to  $V_{PP}$ , and then taking  $\bar{CS}$  low. Five pulses on  $\bar{CS}$  (consisting of  $\bar{CS}$  starting from low and going high for  $t_{CH}$  and then low for  $t_{CL}$ ) program the device (Figure 4). The programming voltage should then be taken to zero. After the device is programmed,  $V_{PP}$  can be set to zero or be allowed to float. The wiper position is still adjustable, but always returns to this programmed position on power-up.

If the intent is to program the device to a specific wiper position and not to allow further adjustments, then six programming pulses are required (as opposed to five), as shown in Figure 4. The sixth pulse locks the wiper position and disables the serial interface. This also allows  $U/\bar{D}$  and  $\bar{CS}$  to float without any increase in supply current. Once the lockout bit is set, no further adjustment to the potentiometer is possible, effectively changing the potentiometer into a fixed resistor-divider (Table 1).

Table 1. One-Time Programming Options

MODE	POWER-ON RESET WIPER POSITION	ADJUSTABLE WIPER
Factory Default (Unprogrammed)	Tap 16	Yes
Programmed (5 Programming Pulses)	Programmed position	Yes
Lock-Bit Set (6 Programming Pulses)	Programmed position	No

# One-Time Programmable, Linear-Taper Digital Potentiometers

MAX5427/MAX5428/MAX5429



Figure 4. One-Time Program Mode Serial Interface Timing Diagram

It is recommended that the user either use six  $\overline{CS}$  pulses (convert to a fixed voltage-divider) or five pulses (program the initial power-up value of the device, but still be able to adjust the wiper). If the device is programmed with five pulses and later it is desired to disable the interface (convert to a fixed voltage-divider), then care must be taken to ensure that the wiper is in the same position as it was originally set to (when programmed with five pulses). The full six programming pulses must be applied. If the wiper is not in its original programmed position prior to disabling the interface, the final locked-out position is correct. Note that once the six-pulse program occurs, no further programming is possible.

The  $V_{PP}$  power supply must be able to source at least 5mA and have a good transient response. The  $V_{PP}$  power supply should be decoupled with 22 $\mu$ F and have no more than 250 $\mu$ H of inductance and/or 40 $\Omega$  of parasitic resistance between the capacitors and the device (Figure 5). The device does not require decoupling capacitors near  $V_{PP}$ , provided the above guidelines are met.



Figure 5.  $V_{PP}$  Power-Supply Connection

## Chip Information

TRANSISTOR COUNT: 2270  
PROCESS: BICMOS

# One-Time Programmable, Linear-Taper Digital Potentiometers

## Package Information

(The package drawing(s) in this data sheet may not reflect the most current specifications. For the latest package outline information, go to [www.maxim-ic.com/packages](http://www.maxim-ic.com/packages).)





# One-Time Programmable, Linear-Taper Digital Potentiometers

## Package Information (continued)

(The package drawing(s) in this data sheet may not reflect the most current specifications. For the latest package outline information, go to [www.maxim-ic.com/packages](http://www.maxim-ic.com/packages).)

MAX5427/MAX5428/MAX5429

COMMON DIMENSIONS		
SYMBOL	MIN.	MAX.
A	0.70	0.80
D	2.90	3.10
E	2.90	3.10
A1	0.00	0.05
L	0.20	0.40
k	0.25 MIN.	
A2	0.20 REF.	

PACKAGE VARIATIONS								
PKG. CODE	N	D2	E2	e	JEDEC SPEC	b	[(N/2)-1] x e	DOWNBONDS ALLOWED
T633-1	6	1.50±0.10	2.30±0.10	0.95 BSC	MO229 / WEEA	0.40±0.05	1.90 REF	NO
T633-2	6	1.50±0.10	2.30±0.10	0.95 BSC	MO229 / WEEA	0.40±0.05	1.90 REF	NO
T833-1	8	1.50±0.10	2.30±0.10	0.65 BSC	MO229 / WEEC	0.30±0.05	1.95 REF	NO
T833-2	8	1.50±0.10	2.30±0.10	0.65 BSC	MO229 / WEEC	0.30±0.05	1.95 REF	NO
T833-3	8	1.50±0.10	2.30±0.10	0.65 BSC	MO229 / WEEC	0.30±0.05	1.95 REF	YES
T1033-1	10	1.50±0.10	2.30±0.10	0.50 BSC	MO229 / WEED-3	0.25±0.05	2.00 REF	NO
T1433-1	14	1.70±0.10	2.30±0.10	0.40 BSC	----	0.20±0.05	2.40 REF	YES
T1433-2	14	1.70±0.10	2.30±0.10	0.40 BSC	----	0.20±0.05	2.40 REF	NO

**NOTES:**

1. ALL DIMENSIONS ARE IN mm. ANGLES IN DEGREES.
2. COPLANARITY SHALL NOT EXCEED 0.08 mm.
3. WARPAGE SHALL NOT EXCEED 0.10 mm.
4. PACKAGE LENGTH/PACKAGE WIDTH ARE CONSIDERED AS SPECIAL CHARACTERISTIC(S).
5. DRAWING CONFORMS TO JEDEC MO229, EXCEPT DIMENSIONS "D2" AND "E2", AND T1433-1 & T1433-2.
6. "N" IS THE TOTAL NUMBER OF LEADS.
7. NUMBER OF LEADS SHOWN ARE FOR REFERENCE ONLY.

-DRAWING NOT TO SCALE-

	
TITLE: PACKAGE OUTLINE, 6, 8, 10 & 14L, TDFN, EXPOSED PAD, 3x3x0.80 mm	
APPROVAL	DOCUMENT CONTROL NO. 21-0137
REV.	G 2/2

# One-Time Programmable, Linear-Taper Digital Potentiometers

## Package Information (continued)

(The package drawing(s) in this data sheet may not reflect the most current specifications. For the latest package outline information, go to [www.maxim-ic.com/packages](http://www.maxim-ic.com/packages).)

8LUMAXD.EPS

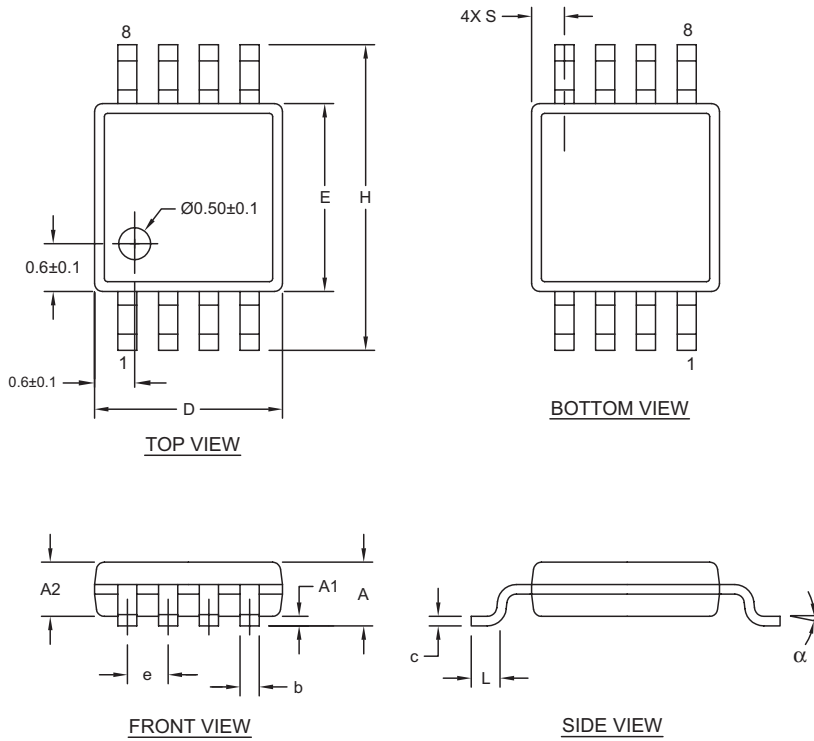

DIM	INCHES		MILLIMETERS	
	MIN	MAX	MIN	MAX
A	-	0.043	-	1.10
A1	0.002	0.006	0.05	0.15
A2	0.030	0.037	0.75	0.95
b	0.010	0.014	0.25	0.36
c	0.005	0.007	0.13	0.18
D	0.116	0.120	2.95	3.05
e	0.0256 BSC		0.65 BSC	
E	0.116	0.120	2.95	3.05
H	0.188	0.198	4.78	5.03
L	0.016	0.026	0.41	0.66
α	0°	6°	0°	6°
S	0.0207 BSC		0.5250 BSC	

- NOTES:
1. D&E DO NOT INCLUDE MOLD FLASH.
  2. MOLD FLASH OR PROTRUSIONS NOT TO EXCEED 0.15MM (.006").
  3. CONTROLLING DIMENSION: MILLIMETERS.
  4. MEETS JEDEC MO-187C-AA.

<small>PROPRIETARY INFORMATION</small>		
<small>TITLE:</small> PACKAGE OUTLINE, 8L uMAX/uSOP		
<small>APPROVAL</small>	<small>DOCUMENT CONTROL NO.</small> 21-0036	<small>REV.</small> J 1/1

Maxim cannot assume responsibility for use of any circuitry other than circuitry entirely embodied in a Maxim product. No circuit patent licenses are implied. Maxim reserves the right to change the circuitry and specifications without notice at any time.

10 **Maxim Integrated Products, 120 San Gabriel Drive, Sunnyvale, CA 94086 408-737-7600**



Компания «ЭлектроПласт» предлагает заключение долгосрочных отношений при поставках импортных электронных компонентов на взаимовыгодных условиях!

Наши преимущества:

- Оперативные поставки широкого спектра электронных компонентов отечественного и импортного производства напрямую от производителей и с крупнейших мировых складов;
- Поставка более 17-ти миллионов наименований электронных компонентов;
- Поставка сложных, дефицитных, либо снятых с производства позиций;
- Оперативные сроки поставки под заказ (от 5 рабочих дней);
- Экспресс доставка в любую точку России;
- Техническая поддержка проекта, помощь в подборе аналогов, поставка прототипов;
- Система менеджмента качества сертифицирована по Международному стандарту ISO 9001;
- Лицензия ФСБ на осуществление работ с использованием сведений, составляющих государственную тайну;
- Поставка специализированных компонентов (Xilinx, Altera, Analog Devices, Intersil, Interpoint, Microsemi, Aeroflex, Peregrine, Syfer, Eurofarad, Texas Instrument, Miteq, Cobham, E2V, MA-COM, Hittite, Mini-Circuits, General Dynamics и др.);

Помимо этого, одним из направлений компании «ЭлектроПласт» является направление «Источники питания». Мы предлагаем Вам помощь Конструкторского отдела:

- Подбор оптимального решения, техническое обоснование при выборе компонента;
- Подбор аналогов;
- Консультации по применению компонента;
- Поставка образцов и прототипов;
- Техническая поддержка проекта;
- Защита от снятия компонента с производства.



#### Как с нами связаться

**Телефон:** 8 (812) 309 58 32 (многоканальный)

**Факс:** 8 (812) 320-02-42

**Электронная почта:** [org@eplast1.ru](mailto:org@eplast1.ru)

**Адрес:** 198099, г. Санкт-Петербург, ул. Калинина, дом 2, корпус 4, литера А.