

30 V_{PP} MONO CLASS-D AUDIO AMPLIFIER FOR PIEZO/CERAMIC SPEAKERS

Description

The PAM8902H is a mono, Class-D audio amplifier with integrated boost convertor designed for piezo and ceramic speakers. The PAM8902H is capable of driving a ceramic/ piezo speaker with 30V_{pp}(10.6V_{rms}) from a 3.6V power supply. The PAM8902H's Boost converter operates at a fixed frequency of 1.5MHz, and provides a 17.5V supply with a minimum number of external components. PAM8902H features an integrated audio low pass filter that rejects high frequency noise thus improving audio fidelity. And three gain modes of 21dB, 26dB and 32.5dB easy for using. PAM8902H also provides thermal, short, under and over voltage protection.

The PAM8902H is available in a 16-ball 1.95mm x 1.95mm CSP package and 16-pin QFN4x4 package.

Features

- Supply Voltage Range From 2.5V to 5.5V
- 30 V_{PP} Output Load Voltage From a 2.5V Supply
- Integrated Boost Converter Generates 17.5V Supply
- Programmable Soft-Start
- Small Boost Converter Inductor
- Selectable Gain of 21dB, 26dB, and 32.5dB
- Selectable Boost Output Voltage of 8V, 12V, and 17.5V
- Low Shutdown Current: <1μA
- Build in Thermal, OCP, OVP, Short Protection
- Available in Space Saving Packages:
 - 16-ball 1.95mmx1.95mm CSP Package
 - 16-pin QFN4x4 Package

Applications

- Wireless or Cellular Handsets
- Portable DVD Player
- Personal Digital Assistants (PDAs)
- Electronic Dictionaries
- Digital Still Cameras

Pin Assignments

16 Ball CSP
Top View

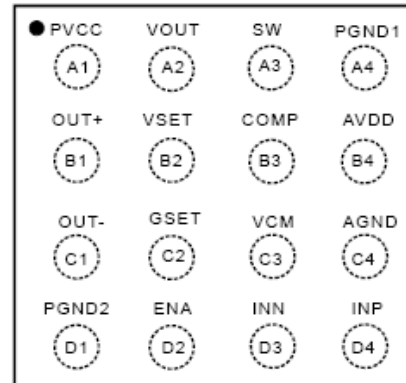

Top View
QFN 4X4 16L

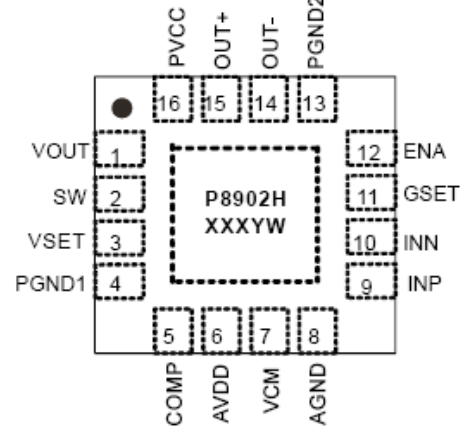

● : Pin 1 Indicator

Typical Applications Circuit

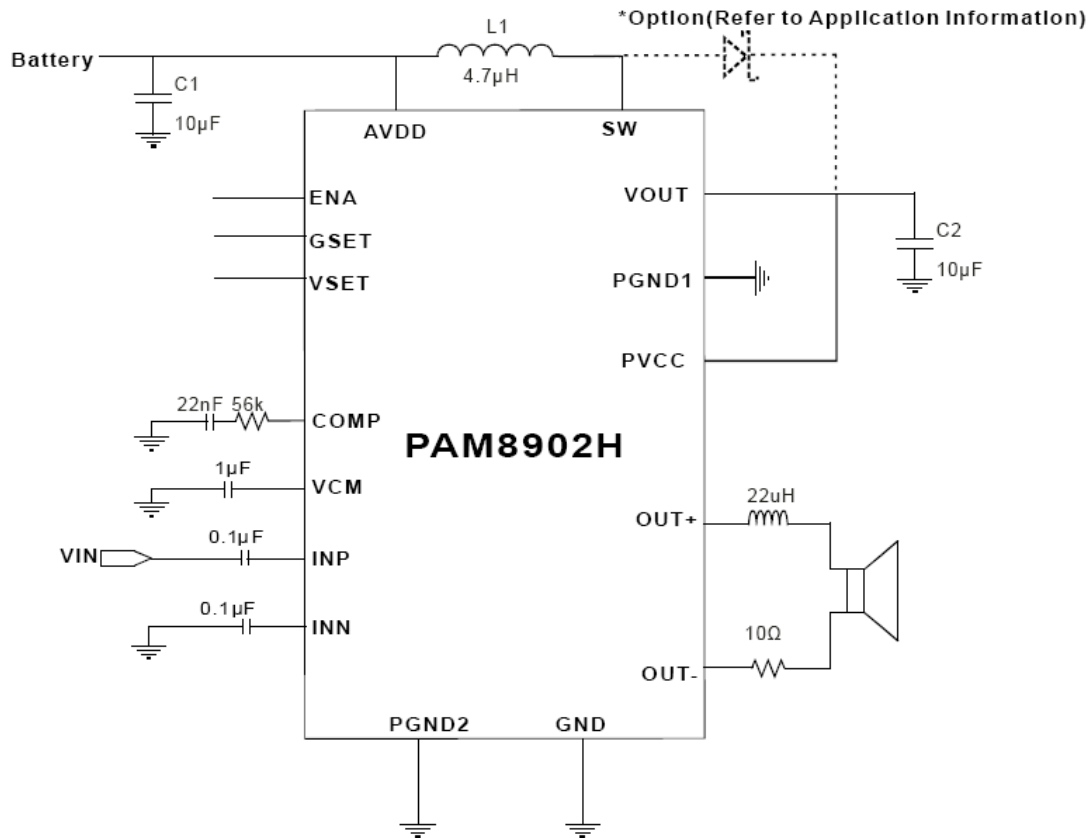

Pin Descriptions

Pin Name	Bump (CSP)	Pin Number (QFN)	Function
PVCC	A1	16	Audio Amplifier Power Supply
VOUT	A2	1	Boost Converter Output
SW	A3	2	Boost Converter Switching Node
PGND1	A4	4	Boost Converter Power Ground
OUT+	B1	15	Positive Differential Audio Output
VSET	B2	3	Boost Converter Output Voltage Setting (8V,12V,17.5V)
COMP	B3	5	Boost Converter compensation
AVDD	B4	6	Power Supply
OUT-	C1	14	Negative Differential Audio Output
GSET	C2	11	Amplifier Gain setting (21dB , 26dB , 32.5dB)
VCM	C3	7	Common Mode bypass Cap
AGND	C4	8	Analog Ground
PGND2	D1	13	Class D Power Ground
ENA	D2	12	Whole chip Enable
INN	D3	10	Negative Differential Audio Input
INP	D4	9	Positive Differential Audio Input

Functional Block Diagram

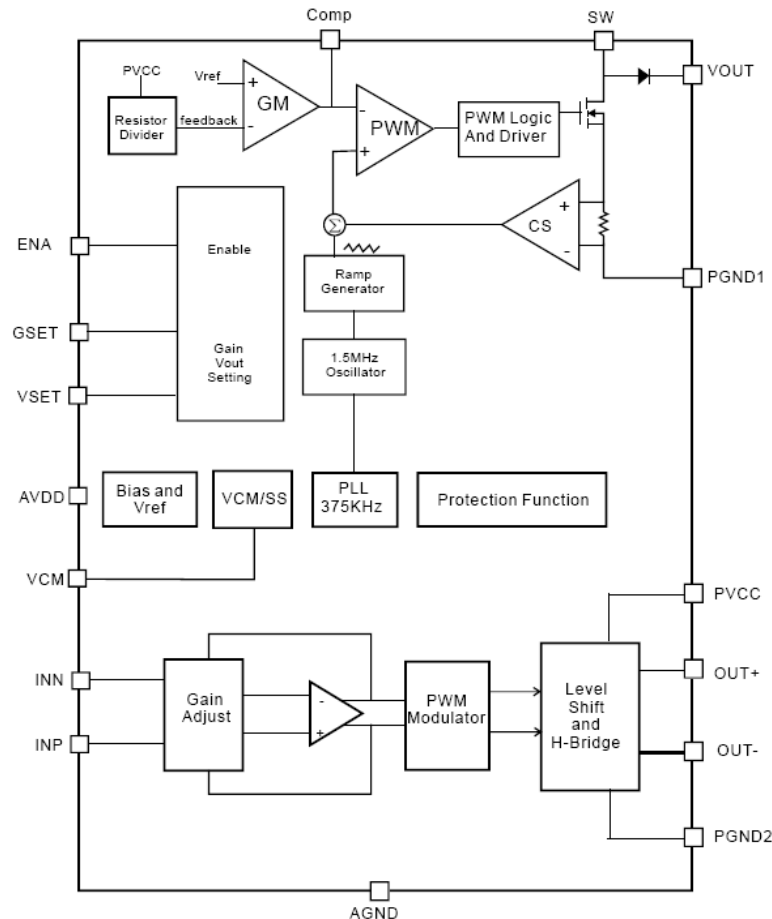

Absolute Maximum Ratings (@T_A = +25°C, unless otherwise specified.)

These are stress ratings only and functional operation is not implied. Exposure to absolute maximum ratings for prolonged time periods may affect device reliability. All voltages are with respect to ground.

Parameter	Rating	Unit
Supply Voltage	6.0	V
Input Voltage	-0.3 to V _{DD} +0.3	
Storage Temperature	-65 to 150	°C
Maximum Junction Temperature	150	
Soldering Temperature	250, 10sec	

Recommended Operating Conditions (@T_A = +25°C, unless otherwise specified.)

Parameter	Rating	Unit
Supply Voltage Range	2.5 to 5.5	V
Ambient Temperature Range	-40 to +85	°C
Junction Temperature Range	-40 to +125	

Thermal Information

Parameter	Symbol	Package	Maximum	Unit
Thermal Resistance (Junction to Ambient)	θ_{JA}	CSP	90	°C/W
		QFN4x4-16	52	
Thermal Resistance (Junction to Case)	θ_{JC}	CSP	72	°C/W
		QFN4x4-16	30	

Electrical Characteristics (@ $T_A = +25^\circ\text{C}$, $V_{DD} = 3.6\text{V}$, $C_L = 1\mu\text{F}$, V_{SET} Float, unless otherwise specified.)

Symbol	Parameter	Conditions	Min	Typ	Max	Unit
V_{DD}	Input Voltage		2.5		5.5	V
I_Q	Quiescent Current	EN > 1.2V, VSET = High		30	48	mA
		EN > 1.2V, VSET = Floating		10	18	
		EN > 1.2V, VSET = GND		5	12	
I_{SD}	Shutdown Current	EN = 0V		0.1	1.0	μA
T_{WU}	Wake-Up Time	EN From Low to High		40		mS
V_{EH}	Chip Enable		1.2			V
V_{EL}	Chip Disable				0.4	
V_H	GSET/VSET High		$V_{DD} - 0.5$		V_{DD}	V
V_F	GSET/VSET Floating		1		$V_{DD} - 1$	
V_L	GSET/VSET Low		0		0.5	
UVLO	Under Voltage Lockout Threshold	V_{DD} From High to Low		2.2		V
UVLO _H	Under Voltage Lockout Hysteresis	V_{DD} From Low to High		0.2		
OTP	Thermal Shutdown Threshold			150		°C
OTPH	Thermal Shutdown Lockout Hysteresis			30		°C
Boost Converter						
V_{O1}	Output Voltage	VSET = GND, No Load	7.2	8.0	8.8	V
V_{O2}		VSET = NC, No Load	10.8	12.0	13.2	V
V_{O3}		VSET = AVDD, No Load	16	17.5	19	V
C_L	Current Limit	Average Input Current		1.0		A
R_{LS}	Low Side MOSFET $R_{DS(ON)}$	$I_O = 50\text{mA}$		0.5		Ω
f_{OSCB}	Boost Switching Frequency		1.1	1.5	1.9	MHz
Class-D						
f_{OSCD}	Class-D Amplifier Switching Frequency	Input AC-GND	225	375	475	KHz
CMRR	Common Mode Reject Ratio	$V_{IN} = \pm 100\text{mV}$, $V_{DD} = 3.6\text{V}$		60		dB
V_{OS}	Output Offset Voltage	Output Offset Voltage		5	50	mV
R_P	$R_{DS(ON)}$	High Side		1.5		Ω
		Low Side		0.6		Ω
A_{V1}	Closed-Loop Voltage Gain	$G_{SET} = AVDD$, $V_O = 1V_{RMS}$		32.5		dB
A_{V2}		$G_{SET} = AVDD$, $V_O = 1V_{RMS}$		26		
A_{V3}		$G_{SET} = AVDD$, $V_O = 1V_{RMS}$		21		
PSRR	Power Supply Reject Ratio	200m V_{PP} Supply Ripple @ 217Hz		70		dB
THD+N	Total Harmonic Distortion Plus Noise	$V_O = 5V_{RMS}$		0.3		%
SNR	Signal to Noise Ratio	Input AC Ground, A-Weighting		90		dB

Typical Operating Characteristics

(@T_A = +25°C, V_{DD} = 4.2V, Gain = 26dB, C_{IN} = 1μF, C_{LOAD} = 1μF, unless otherwise specified.)

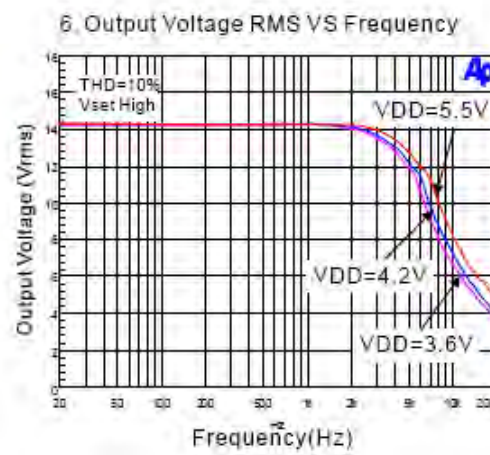
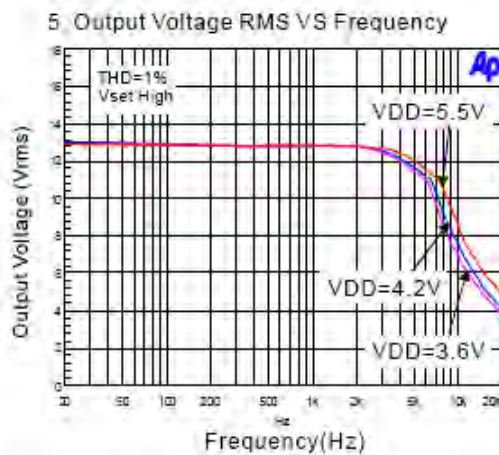
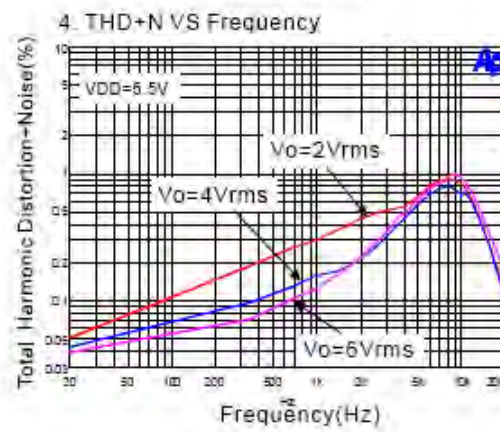
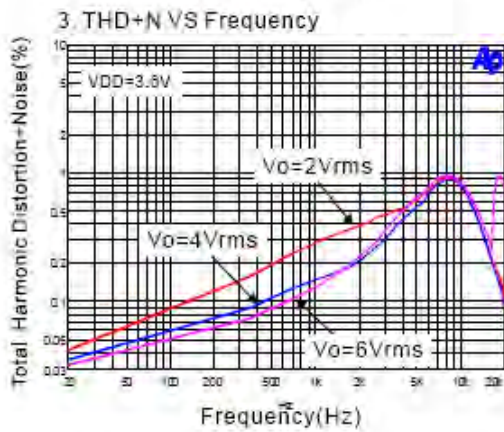
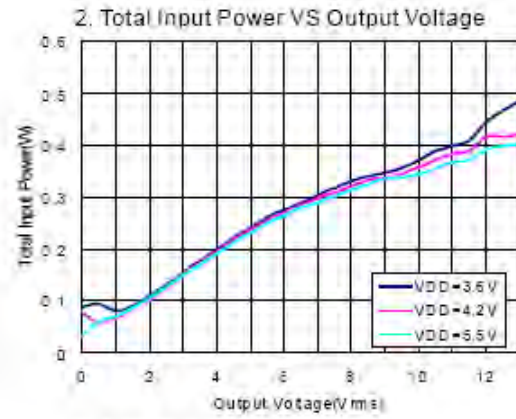
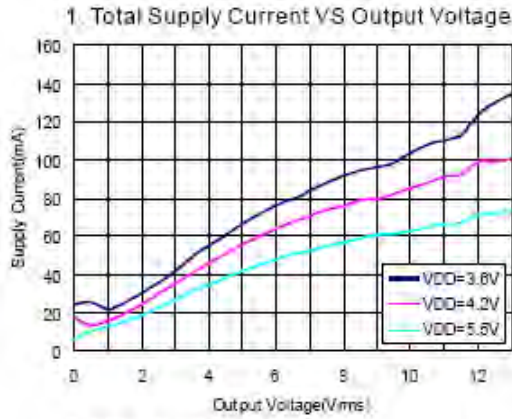

Typical Operating Characteristics (cont.) (@ $T_A = +25^\circ\text{C}$, $V_{DD} = 5\text{V}$, Gain = 18dB, unless otherwise specified.)

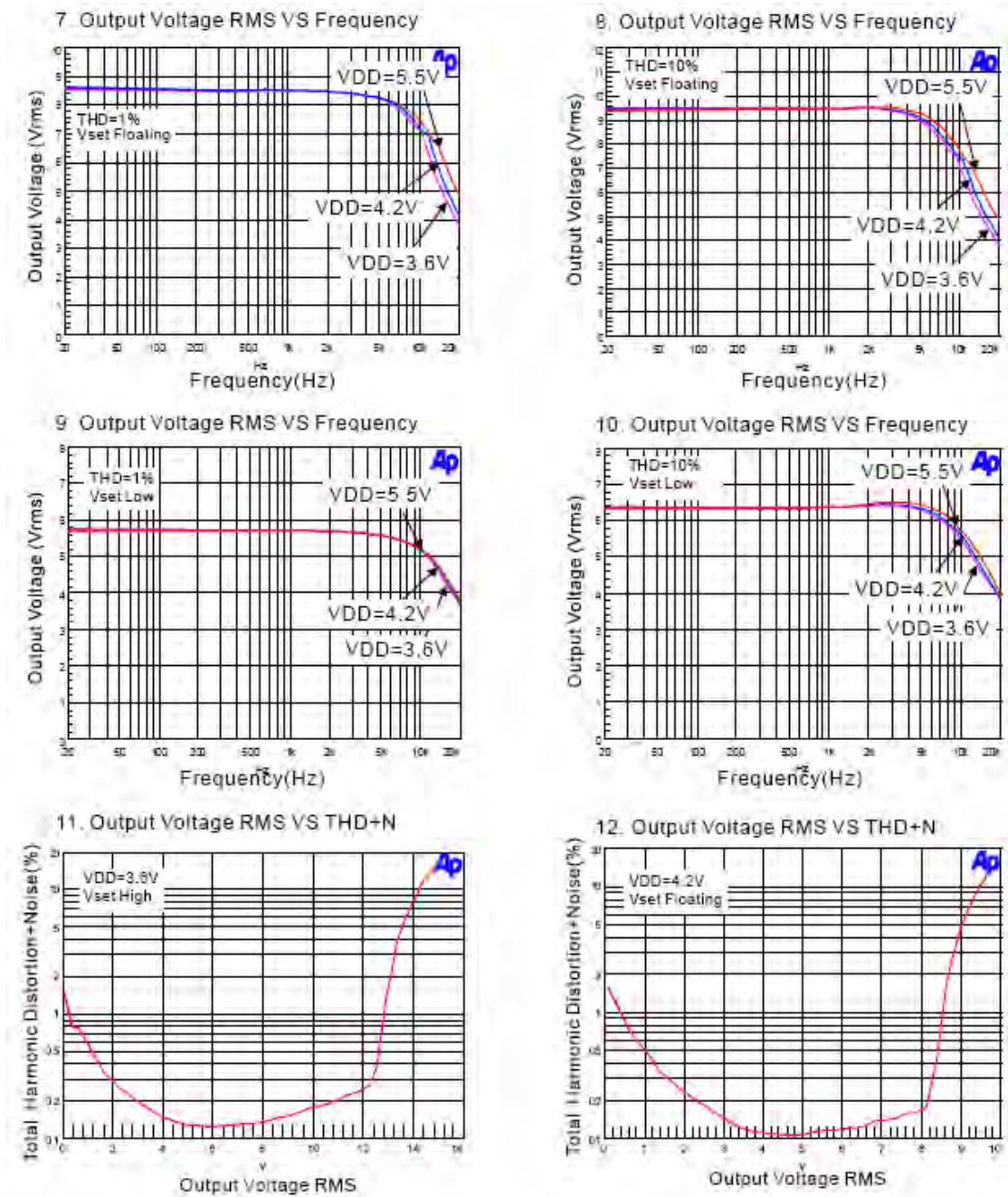

Application Information

Select Boost Converter Output Voltage

Customer can use V_{SET} pin to set boost converter output voltage between 8V, 12V and 17.5V. V_{SET} pin configuration table as below:

V_{SET} Pin Configuration	Min	Max	PVCC Voltage	Audio Amplifier Maximum Output Voltage
Connect to AVDD	AVDD – 0.5V	AVDD	17.5V	11V _{RMS} ($V_{PP} = 31.1V$)
Floating	1V	AVDD – 1V	12V	5V _{RMS} ($V_{PP} = 22.6V$)
Connect to GND	GND	0.5V	8V	5V _{RMS} ($V_{PP} = 14.1V$)

Input Resistance (R_I)

The input resistors ($R_I = R_{IN} + R_{EX}$) set the gain of the amplifier according to Equation 1 when anti-saturation is inactive.

$$G = 20 \text{ Log } [12.8 \cdot R_F / (R_{IN} + R_{EX})] \text{ (dB)}$$

G_{SET}	R_{IN}	R_F
$G_{SET} = V_{DD}$	36.5k Ω	122.6k Ω
$G_{SET} = \text{Floating}$	59k Ω	100k Ω
$G_{SET} = \text{GND}$	82k Ω	77.4k Ω

Where R_{IN} is a 77.4k Ω internal resistor, R_{EX} is the external input resistor, R_F is a 122.6k Ω internal resistor. Resistor matching is very important in fully differential amplifiers. The balance of the output on the reference voltage depends on matched ratios of the resistors. CMRR, PSRR, and cancellation of the second harmonic distortion diminish if resistor mismatch occurs. Therefore, it is recommended to use 1% tolerance resistors or better to keep the performance optimized. Matching is more important than overall tolerance. Resistor arrays with 1% matching can be used with a tolerance greater than 1%.

Place the input resistors very close to the PAM8902H to limit noise injection on the high-impedance nodes. For optimal performance the gain should be set to lower. Lower gain allows the PAM8902H to operate at its best, and keeps a high voltage at the input making the inputs less susceptible to noise. In addition to these features, higher value of R_I minimizes pop noise.

Input Capacitors (C_I)

In the typical application, an input capacitor, C_I , is required to allow the amplifier to bias the input signal to the proper DC level for optimum operation. In this case, C_I and the minimum input impedance R_I form a high-pass filter with the corner frequency determined in the follow equation:

$$f_C = \frac{1}{2\pi R_I C_I}$$

It is important to consider the value of C_I as it directly affects the low frequency performance of the circuit. For example, when R_I is 150k Ω and the specification calls for a flat bass response are down to 150Hz. Equation is reconfigured as followed:

$$C_I = \frac{1}{2\pi R_{IFC}}$$

When input resistance variation is considered, the C_I is 7nF, so one would likely choose a value of 10nF. A further consideration for this capacitor is the leakage path from the input source through the input network (C_I , $R_I + R_F$) to the load. This leakage current creates a DC offset voltage at the input to the amplifier that reduces useful headroom, especially in high gain applications. For this reason, a low-leakage tantalum or ceramic capacitor is the best choice. When polarized capacitors are used, the positive side of the capacitor should face the amplifier input in most applications as the DC level is held at $V_{DD}/2$, which is likely higher than the source DC level. Please note that it is important to confirm the capacitor polarity in the application.

Application Information (cont.)

Decoupling Capacitor

The PAM8902H is a high-performance CMOS audio amplifier that requires adequate power supply decoupling to ensure the output total harmonic distortion (THD) as low as possible.

The optimum decoupling is achieved by using two different types of capacitors that target on different types of noise on the power supply leads. For higher frequency transients, spikes or digital hash on the line, a good low equivalent series-resistance (ESR) ceramic capacitor, typically 1 μ F, is placed as close as possible to the device AVDD pin for the best operation. For filtering lower frequency noise signals, a large ceramic capacitor of 10 μ F or greater placed near the AVDD supply trace is recommended.

External Schottky Diode

Use external schottky diode can get the best driving capability and efficiency. Since internal power diode has limited driving capability, only in following conditions customer can remove the external schottky diode to reduce the cost.

1. $V_{SET} = GND$ or Floating and C_L less than 1 μ F.
2. The signal frequency less than 4KHz.
3. Haptic application (50-500Hz)

Shutdown Operation

In order to reduce power consumption while not in use, the PAM8902H contains shutdown circuitry amplifier off when a logic low is placed on the ENA pin. By switching the ENA pin connected to GND, the PAM8902H supply current draw will be minimized in idle mode.

Under Voltage Lock-out (UVLO)

The PAM8902H incorporates circuitry designed to detect supply voltage. When the supply voltage drops to 2.2V or below, the PAM8902H goes into a state of shutdown, and the device comes out of its shutdown state and restore to normal function only when reset the power supply or ENA pin.

Short Circuit Protection (SCP)

The PAM8902H has short circuit protection circuitry on the outputs to prevent the device from damage when output-to-output shorted or output-to-GND shorted occurs. When a short circuit occurs, the device goes into a latch state and must be reset by cycling the voltage on the ENA pin to a logic low and then back to the logic high state for normal operation. This will clear the short-circuit flag and allow for normal operation if the short was removed. If the short was not removed, the protection circuitry will again activate.

Over Temperature Protection (OTP)

Thermal protection on the PAM8902H prevents the device from damage when the internal die temperature exceeds +150°C. There is a 15°C tolerance on this trip point from device to device. Once the die temperature exceeds the set point, the device will enter the shutdown state and the outputs are disabled, in this condition both OUT+ and OUT- will become high impedance. This is not a latched fault. The thermal fault is cleared once the temperature of the die decreased by 30°C. This large hysteresis will prevent motor boating sound well and the device begins normal operation at this point with no external system interaction.

Ordering Information

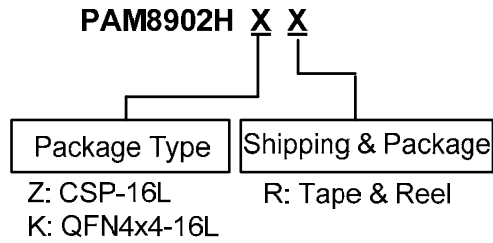

Part Number	Part Marking	Package Type	Standard Package
PAM8902HZER	BT YW	CSP-16L	3000 Units/Tape&Reel
PAM8902HKER	P8902H XXXYW	QFN4x4-16L	3000 Units/Tape&Reel

Marking Information

16 Ball CSP
Top View

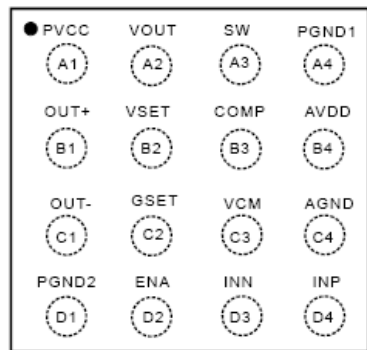

Marking

BT
YW

BT: Product Code of PAM8902H
Y: Year
W: Week

Top View
QFN 4X4 16L

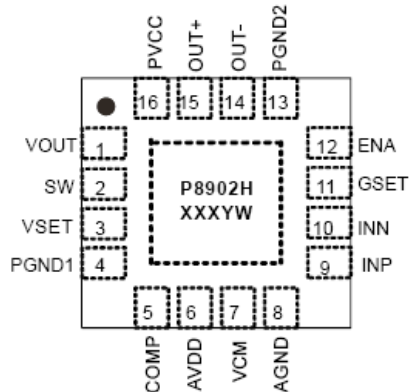

Y: Year
W: Week
X: Internal Code

Package Outline Dimensions (All dimensions in mm.)

CSP-16

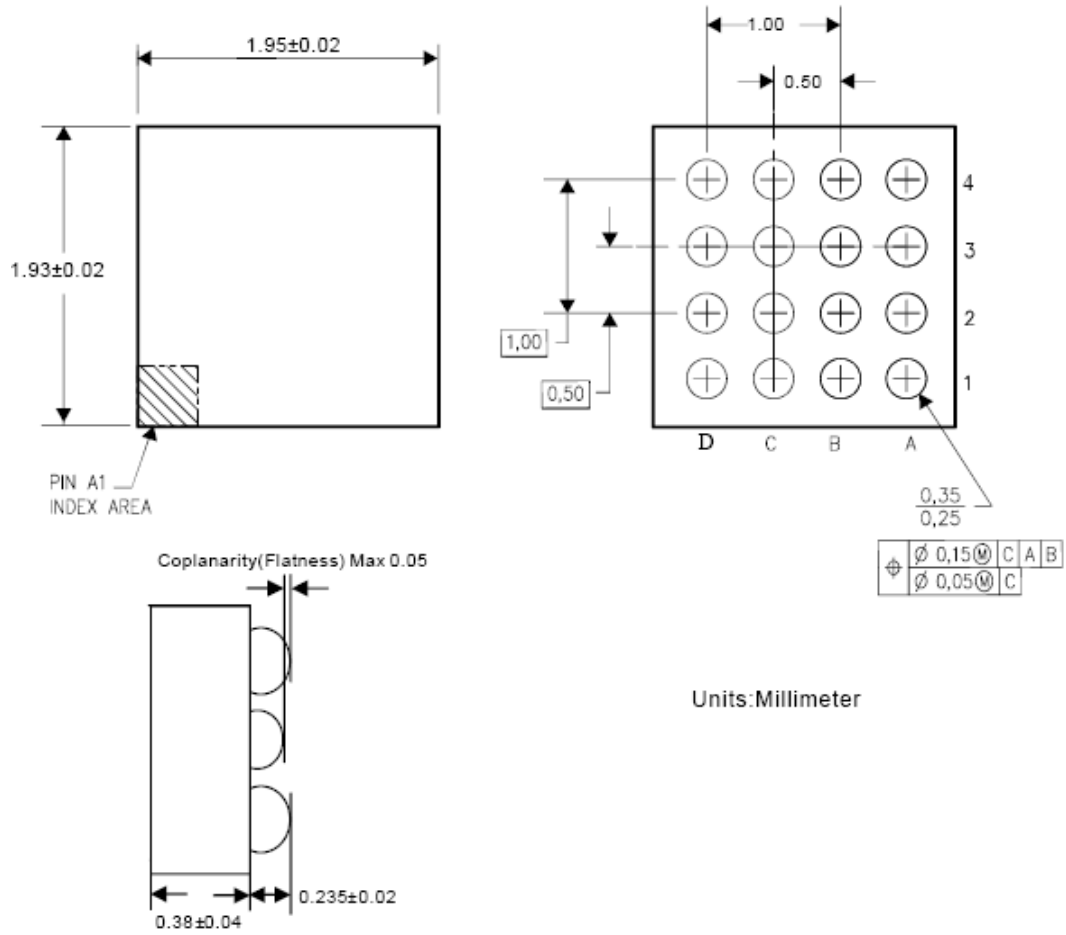

Package Outline Dimensions (All dimensions in mm.)

QFN4x4-16

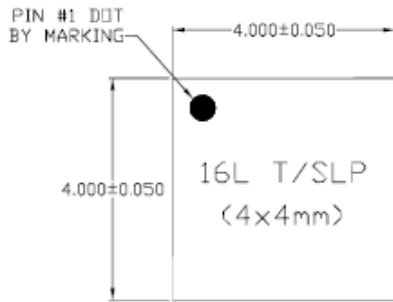

TOP VIEW

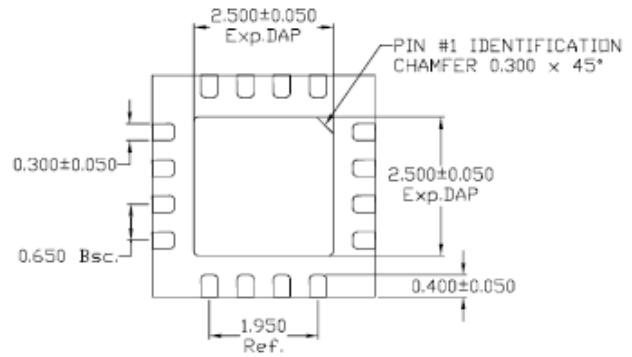

BOTTOM VIEW

NOTE:

1) TSLP AND SLP SHARE THE SAME EXPOSE OUTLINE BUT WITH DIFFERENT THICKNESS:

A		TSLP	SLP
	MAX.	0.800	0.900
NOM.	0.750	0.850	
MIN.	0.700	0.800	

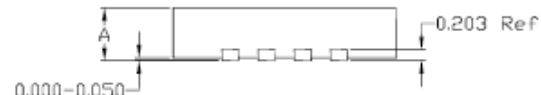

SIDE VIEW

IMPORTANT NOTICE

DIODES INCORPORATED MAKES NO WARRANTY OF ANY KIND, EXPRESS OR IMPLIED, WITH REGARDS TO THIS DOCUMENT, INCLUDING, BUT NOT LIMITED TO, THE IMPLIED WARRANTIES OF MERCHANTABILITY AND FITNESS FOR A PARTICULAR PURPOSE (AND THEIR EQUIVALENTS UNDER THE LAWS OF ANY JURISDICTION).

Diodes Incorporated and its subsidiaries reserve the right to make modifications, enhancements, improvements, corrections or other changes without further notice to this document and any product described herein. Diodes Incorporated does not assume any liability arising out of the application or use of this document or any product described herein; neither does Diodes Incorporated convey any license under its patent or trademark rights, nor the rights of others. Any Customer or user of this document or products described herein in such applications shall assume all risks of such use and will agree to hold Diodes Incorporated and all the companies whose products are represented on Diodes Incorporated website, harmless against all damages.

Diodes Incorporated does not warrant or accept any liability whatsoever in respect of any products purchased through unauthorized sales channel. Should Customers purchase or use Diodes Incorporated products for any unintended or unauthorized application, Customers shall indemnify and hold Diodes Incorporated and its representatives harmless against all claims, damages, expenses, and attorney fees arising out of, directly or indirectly, any claim of personal injury or death associated with such unintended or unauthorized application.

Products described herein may be covered by one or more United States, international or foreign patents pending. Product names and markings noted herein may also be covered by one or more United States, international or foreign trademarks.

This document is written in English but may be translated into multiple languages for reference. Only the English version of this document is the final and determinative format released by Diodes Incorporated.

LIFE SUPPORT

Diodes Incorporated products are specifically not authorized for use as critical components in life support devices or systems without the express written approval of the Chief Executive Officer of Diodes Incorporated. As used herein:

A. Life support devices or systems are devices or systems which:

1. are intended to implant into the body, or
2. support or sustain life and whose failure to perform when properly used in accordance with instructions for use provided in the labeling can be reasonably expected to result in significant injury to the user.

B. A critical component is any component in a life support device or system whose failure to perform can be reasonably expected to cause the failure of the life support device or to affect its safety or effectiveness.

Customers represent that they have all necessary expertise in the safety and regulatory ramifications of their life support devices or systems, and acknowledge and agree that they are solely responsible for all legal, regulatory and safety-related requirements concerning their products and any use of Diodes Incorporated products in such safety-critical, life support devices or systems, notwithstanding any devices- or systems-related information or support that may be provided by Diodes Incorporated. Further, Customers must fully indemnify Diodes Incorporated and its representatives against any damages arising out of the use of Diodes Incorporated products in such safety-critical, life support devices or systems.

Copyright © 2012, Diodes Incorporated

www.diodes.com



Компания «ЭлектроПласт» предлагает заключение долгосрочных отношений при поставках импортных электронных компонентов на взаимовыгодных условиях!

Наши преимущества:

- Оперативные поставки широкого спектра электронных компонентов отечественного и импортного производства напрямую от производителей и с крупнейших мировых складов;
- Поставка более 17-ти миллионов наименований электронных компонентов;
- Поставка сложных, дефицитных, либо снятых с производства позиций;
- Оперативные сроки поставки под заказ (от 5 рабочих дней);
- Экспресс доставка в любую точку России;
- Техническая поддержка проекта, помощь в подборе аналогов, поставка прототипов;
- Система менеджмента качества сертифицирована по Международному стандарту ISO 9001;
- Лицензия ФСБ на осуществление работ с использованием сведений, составляющих государственную тайну;
- Поставка специализированных компонентов (Xilinx, Altera, Analog Devices, Intersil, Interpoint, Microsemi, Aeroflex, Peregrine, Syfer, Eurofarad, Texas Instrument, Miteq, Cobham, E2V, MA-COM, Hittite, Mini-Circuits, General Dynamics и др.);

Помимо этого, одним из направлений компании «ЭлектроПласт» является направление «Источники питания». Мы предлагаем Вам помощь Конструкторского отдела:

- Подбор оптимального решения, техническое обоснование при выборе компонента;
- Подбор аналогов;
- Консультации по применению компонента;
- Поставка образцов и прототипов;
- Техническая поддержка проекта;
- Защита от снятия компонента с производства.



Как с нами связаться

Телефон: 8 (812) 309 58 32 (многоканальный)

Факс: 8 (812) 320-02-42

Электронная почта: org@eplast1.ru

Адрес: 198099, г. Санкт-Петербург, ул. Калинина, дом 2, корпус 4, литера А.