

NHD-12864AZ-FSW-GBW-VZ

Graphic Liquid Crystal Display Module

NHD-	Newhaven Display
12864-	128 x 64 pixels
AZ-	Model
F-	Transflective
SW-	Side White LED backlight
G-	STN- Gray
B-	6:00 View
W-	Wide Temperature (-20°C ~ +70°C)
VZ-	With Built-in Negative Voltage Supply
	RoHS Compliant-8.8

Newhaven Display International, Inc.

2511 Technology Drive, Suite 101

Elgin IL, 60124

Ph: 847-844-8795

Fax: 847-844-8796

www.newhavendisplay.com

nhtech@newhavendisplay.com

nhsales@newhavendisplay.com

Document Revision History

Revision	Date	Description	Changed by
0	11/15/2008	Initial Release	-
1	4/2/2010	User guide reformat	BE
2	5/6/2010	Block diagram/initialization updated	BE
3	1/21/2011	Update Electrical Characteristics	JT
4	12/17/2012	Controller information updated	AK

Functions and Features

- 128x64 pixels
- Built-in NT7108C controller
- +5.0V power supply
- 1/64 duty, 1/9 bias
- RoHS Compliant

Mechanical Drawing

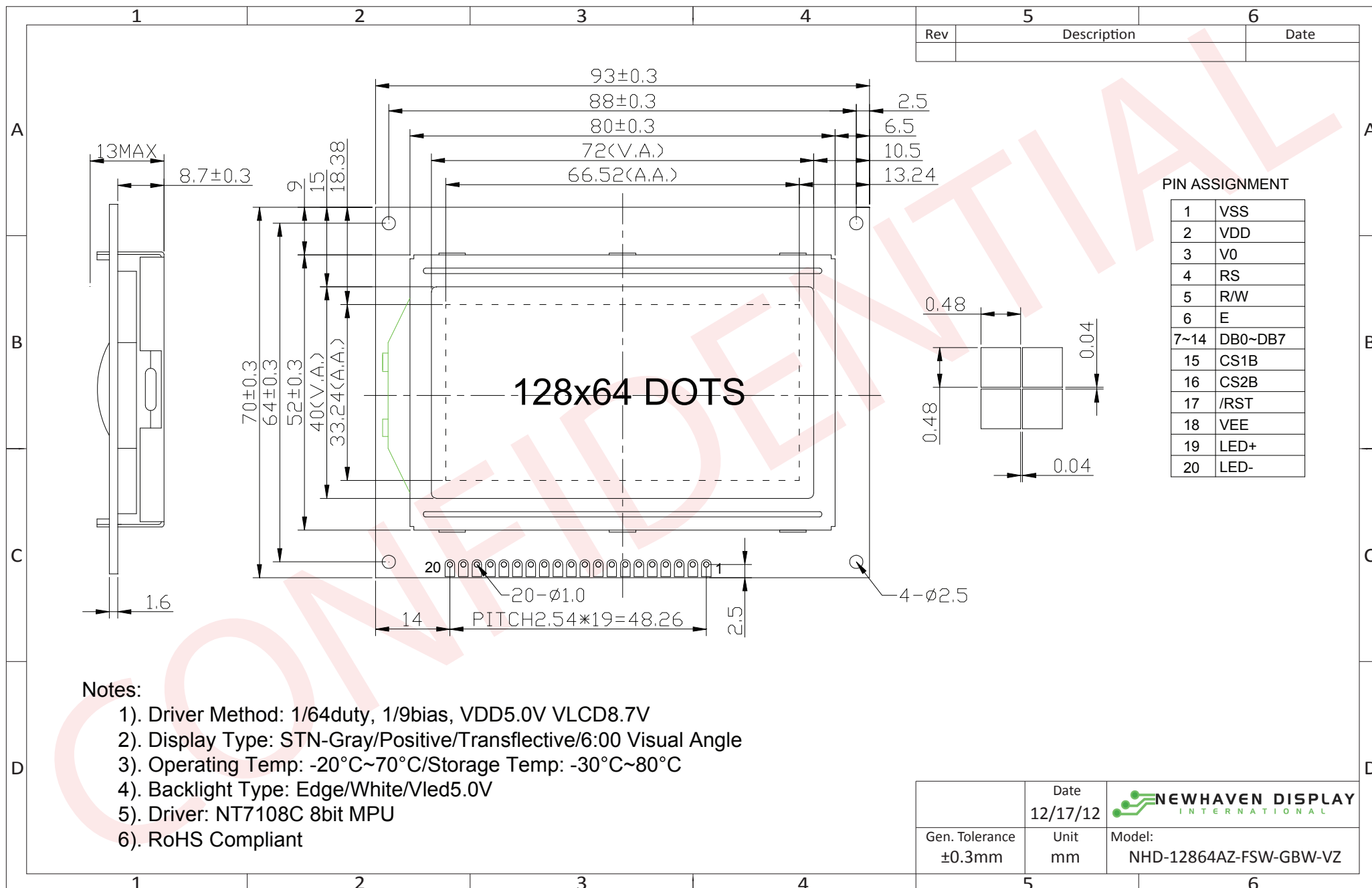

	Date	 NEWHAVEN DISPLAY INTERNATIONAL
	12/17/12	
Gen. Tolerance	Unit	Model:
±0.3mm	mm	NHD-12864AZ-FSW-GBW-VZ

The drawing contained herein is the exclusive property of Newhaven Display International, Inc. and shall not be copied, reproduced, and/or disclosed in any format without permission.

Pin Description and Wiring Diagram

Pin No.	Symbol	External Connection	Function Description
1	VSS	Power Supply	Ground
2	VDD	Power Supply	Power supply for Logic (+5.0V)
3	V0	Adj Power Supply	Power Supply for contrast (approx. -8.8V)
4	RS	MPU	Register select: 1=Data, 0=Instruction
5	R/W	MPU	Read/Write select signal, R/W=1: Read R/W: =0: Write
6	E	MPU	Operation enable signal. Falling edge triggered.
7-14	DB0-DB7	MPU	This is an 8-bit Bi-directional data bus
15	CS1B	MPU	Chip Selection: CS1=H, CS2=L → select IC1 (left side) CS1=L, CS2=H → select IC2 (right side)
16	CS2B	MPU	
17	/RES	MPU	Active LOW Reset signal
18	VEE	Power Supply	Negative voltage output (-10V)
19	LED+	Power Supply	Power for LED backlight (+5.0V via on-board resistor)
20	LED-	Power Supply	Ground for Backlight

Recommended LCD connector: 2.54mm pitch pins

Backlight connector: ----

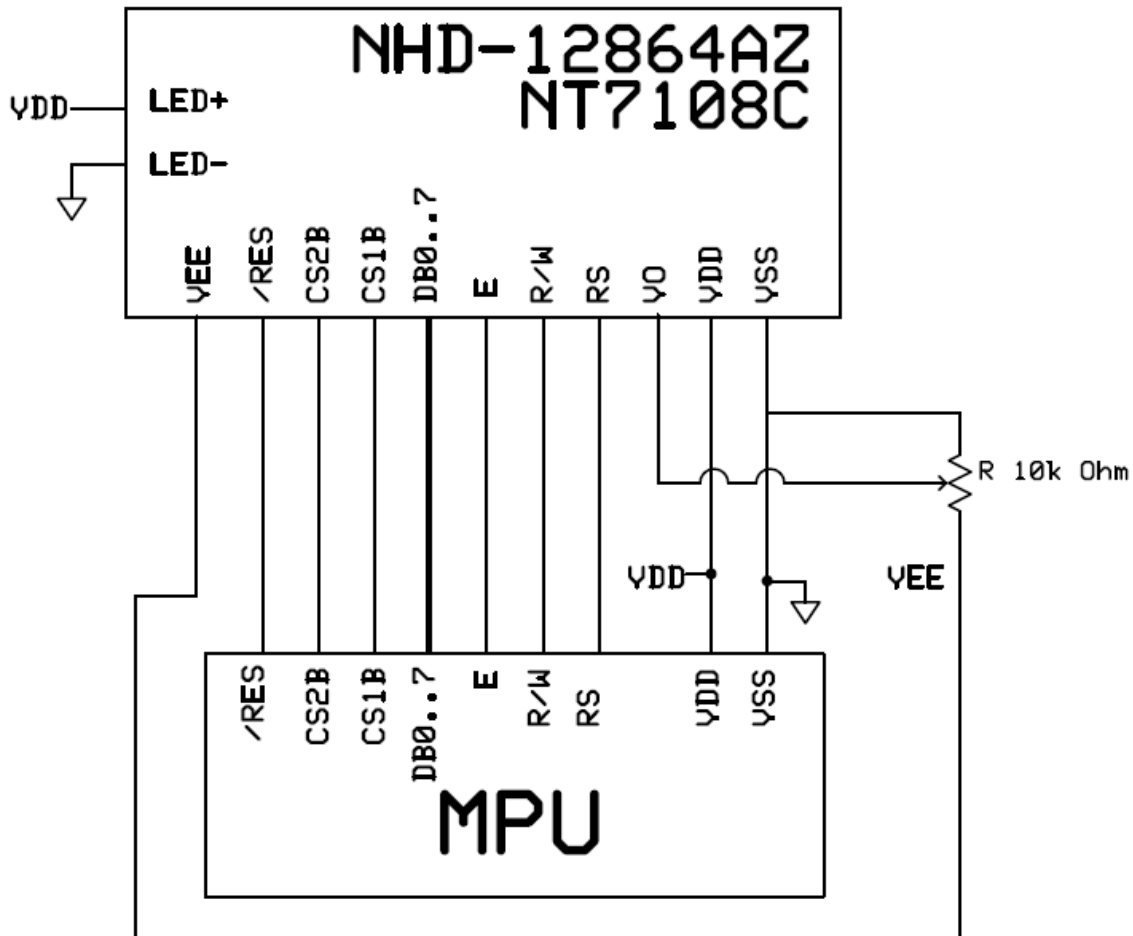

Electrical Characteristics

Item	Symbol	Condition	Min.	Typ.	Max.	Unit
Operating Temperature Range	Top	Absolute Max	-20	-	+70	°C
Storage Temperature Range	Tst	Absolute Max	-30	-	+80	°C
Supply Voltage	VDD		4.7	5.0	5.5	V
Supply Current	IDD	Ta=25°, VDD=5.0V	-	3.5	4.5	mA
Supply for LCD (contrast)	VDD-V0	Ta=25°		8.7	9.0	V
"H" Level input	Vih		0.7*VDD	-	VDD	V
"L" Level input	Vil		0	-	0.3*VDD	V
"H" Level output	Voh		2.4	-	-	V
"L" Level output	Vol		-	-	0.4	V
Backlight Supply Voltage	Vled		-	5.0	-	V
Backlight Supply Current	Iled	Vled=5.0V, R=68Ω	-	30	50	mA

Optical Characteristics

Item	Symbol	Condition	Min.	Typ.	Max.	Unit
Viewing Angle – Top		Cr ≥ 2	-	35	-	°
Viewing Angle – Bottom			-	60	-	°
Viewing Angle – Left			-	40	-	°
Viewing Angle – Right			-	40	-	°
Contrast Ratio	Cr		3	5	-	
Response Time (rise)	Tr		-	150	250	ms
Response Time (fall)	Tf		-	200	300	ms

Controller Information

Built-in NT7108C controller.

Please download specification at http://www.newhavendisplay.com/app_notes/NT7108.pdf

Table of Commands

Instruction	RS	R/W	DB7	DB6	DB5	DB4	DB3	DB2	DB1	DB0	Function	
Display on/off	L	L	L	L	H	H	H	H	H	L/H	Controls the display on or off. Internal status and display RAM data is not affected. L:OFF, H:ON	
Set address (Y address)	L	L	L	H	Y address (0-63)						Sets the Y address in the Y address counter.	
Set page (X address)	L	L	H	L	H	H	H	Page (0-7)			Sets the X address at the X address register.	
Display Start line (Z address)	L	L	H	H	Display start line (0-63)						Indicates the display data RAM displayed at the top of the screen.	
Status read	L	H	Busy	L	On/Off	Reset	L	L	L	L	Read status. BUSY L: Ready H: In operation ON/OFF L: Display ON H: Display OFF RESET L: Normal H: Reset	
Write display data	H	L	Write data									Writes data (DB0: 7) into display data RAM. After writing instruction, Y address is increased by 1 automatically.
Read display data	H	H	Read data									Reads data (DB0: 7) from display data RAM to the data bus.

Timing Characteristics

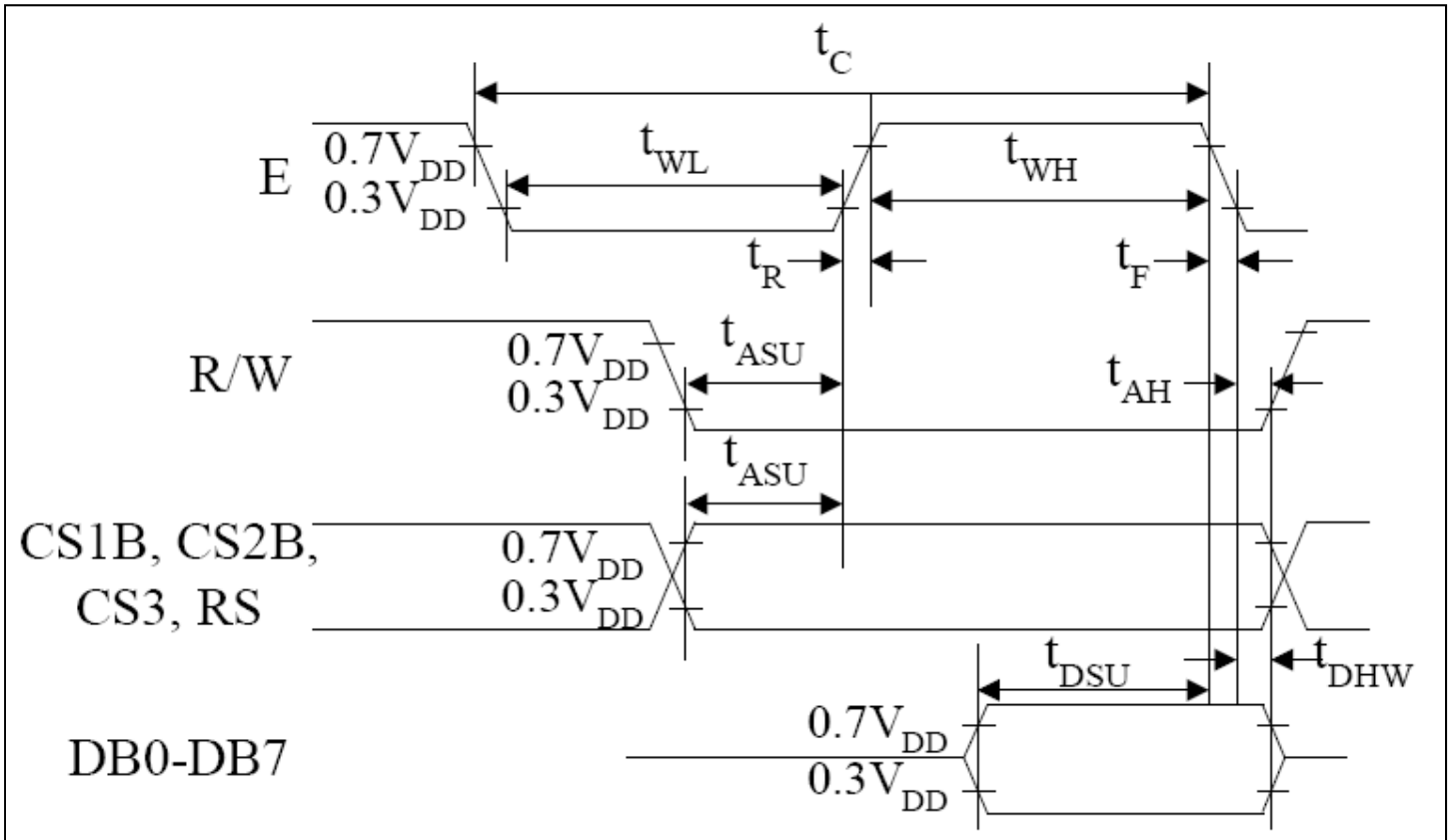

Characteristic	Symbol	Min	Type	Max	Unit
E cycle	t_c	1000	-	-	ns
E high level width	t_{WH}	450	-	-	
E low level width	t_{WL}	450	-	-	
E rise time	t_R	-	-	25	
E fall time	t_F	-	-	25	
Address set-up time	t_{ASU}	140	-	-	
Address hold time	t_{AH}	10	-	-	
Data set-up time	t_{DSU}	200	-	-	
Data delay time	t_D	-	-	320	
Data hold time (write)	t_{DHW}	10	-	-	
Data hold time (read)	t_{DHR}	20	-	-	

Example Initialization Program

```
'-----  
'DB0-DB7  7-14          P1  
'CS2      16           P3.6  
'CS1      15           P3.1  
'RST      17           P3.2  
'R/W      5            P3.7  
'D/I      4            P3.0  
'E        6            P3.4  
'-----  
Sub Init  
  Reset P3.2  
  Set P3.2  
  Reset P3.4  
  Reset P3.0  
  Reset P3.7  
  Reset P3.6  
  Reset P3.1  
  A = &H3F  
  Call Comleft           'display on  
  Call Comright         'display on  
End Sub  
'-----  
Sub Comleft  
  P1 = A  
  Set P3.6  
  Reset P3.0  
  Set P3.4  
  Reset P3.4  
  Reset P3.6  
End Sub  
  
Sub Comright  
  P1 = A  
  Set P3.1  
  Reset P3.0  
  Set P3.4  
  Reset P3.4  
  Reset P3.1  
End Sub  
  
Sub Writeleft  
  P1 = A  
  Set P3.6  
  Set P3.0  
  Set P3.4  
  Reset P3.4  
  Reset P3.6  
End Sub  
  
Sub Writeright  
  P1 = A  
  Set P3.1  
  Set P3.0  
  Set P3.4  
  Reset P3.4  
  Reset P3.1  
End Sub
```

Quality Information

Test Item	Content of Test	Test Condition	Note
High Temperature storage	Endurance test applying the high storage temperature for a long time.	+80°C , 48hrs	2
Low Temperature storage	Endurance test applying the low storage temperature for a long time.	-30°C , 48hrs	1,2
High Temperature Operation	Endurance test applying the electric stress (voltage & current) and the high thermal stress for a long time.	+70°C , 48hrs	2
Low Temperature Operation	Endurance test applying the electric stress (voltage & current) and the low thermal stress for a long time.	-20°C , 48hrs	1,2
High Temperature / Humidity Operation	Endurance test applying the electric stress (voltage & current) and the high thermal with high humidity stress for a long time.	+40°C , 90% RH , 48hrs	1,2
Thermal Shock resistance	Endurance test applying the electric stress (voltage & current) during a cycle of low and high thermal stress.	0°C,30min -> 25°C,5min -> 50°C,30min = 1 cycle 10 cycles	
Vibration test	Endurance test applying vibration to simulate transportation and use.	10-55Hz , 15mm amplitude. 60 sec in each of 3 directions X,Y,Z For 15 minutes	3
Static electricity test	Endurance test applying electric static discharge.	VS=800V, RS=1.5kΩ, CS=100pF One time	

Note 1: No condensation to be observed.

Note 2: Conducted after 4 hours of storage at 25°C, 0%RH.

Note 3: Test performed on product itself, not inside a container.

Precautions for using LCDs/LCMs

See Precautions at www.newhavendisplay.com/specs/precautions.pdf

Warranty Information and Terms & Conditions

http://www.newhavendisplay.com/index.php?main_page=terms



Компания «ЭлектроПласт» предлагает заключение долгосрочных отношений при поставках импортных электронных компонентов на взаимовыгодных условиях!

Наши преимущества:

- Оперативные поставки широкого спектра электронных компонентов отечественного и импортного производства напрямую от производителей и с крупнейших мировых складов;
- Поставка более 17-ти миллионов наименований электронных компонентов;
- Поставка сложных, дефицитных, либо снятых с производства позиций;
- Оперативные сроки поставки под заказ (от 5 рабочих дней);
- Экспресс доставка в любую точку России;
- Техническая поддержка проекта, помощь в подборе аналогов, поставка прототипов;
- Система менеджмента качества сертифицирована по Международному стандарту ISO 9001;
- Лицензия ФСБ на осуществление работ с использованием сведений, составляющих государственную тайну;
- Поставка специализированных компонентов (Xilinx, Altera, Analog Devices, Intersil, Interpoint, Microsemi, Aeroflex, Peregrine, Syfer, Eurofarad, Texas Instrument, Miteq, Cobham, E2V, MA-COM, Hittite, Mini-Circuits, General Dynamics и др.);

Помимо этого, одним из направлений компании «ЭлектроПласт» является направление «Источники питания». Мы предлагаем Вам помощь Конструкторского отдела:

- Подбор оптимального решения, техническое обоснование при выборе компонента;
- Подбор аналогов;
- Консультации по применению компонента;
- Поставка образцов и прототипов;
- Техническая поддержка проекта;
- Защита от снятия компонента с производства.



Как с нами связаться

Телефон: 8 (812) 309 58 32 (многоканальный)

Факс: 8 (812) 320-02-42

Электронная почта: org@eplast1.ru

Адрес: 198099, г. Санкт-Петербург, ул. Калинина, дом 2, корпус 4, литера А.