

SINGLE PHASE VARIABLE SPEED MOTOR CONTROL PRE-DRIVER
Description

The ZXBM1021 is a high performance, low noise, single-phase, Direct Current Brushless (BLDC) motor pre-driver with variable PWM speed control and current control suitable for fan and blower motors.

For system flexibility the motor speed can be controlled by either an external PWM control signal or by a DC voltage signal from an external control voltage or from a Thermistor network.

To prevent motor inrush current the device has a soft start feature. To help protect the motor coil, the ZXBM1021 provides rotor lock protection which shuts down the output drive if rotor lock is detected. The device automatically re-starts with soft-start when the rotor lock is removed. The ZXBM1021 monitors the motor current to provide a programmable over current limit.

A Tachometer output is provided by the open collector output Frequency Generator (FG) pin which allows external interface to monitor motor rotation or speed. The FG output is the magnetic change frequency.

The ZXBM1021 is available in space saving and low profile U-QFN4040-20 and industry standard QSOP-20 packages.

Features

- Operating voltage: 6.8V to 18V
 - Can be extended with external regulator
- Speed control via external PWM, DC or Thermistor signals
- Low noise, high efficiency
- Soft start
- Integrated current control
- Reference voltage output
- Built-in Hall amplifier for direct connection of Hall element
- Rotor Lock Protection
 - Lock detection, output shutdown and automatic re-start
- Minimum speed setting
- Frequency generator (FG) output
- Thermally enhanced space saving low profile U-QFN4040-20 and industry standard QSOP-20 packages
- **Totally Lead-Free & Fully RoHS Compliant (Notes 1 & 2)**
- **Halogen and Antimony Free. "Green" Device (Note 3)**

Notes: 1. No purposely added lead. Fully EU Directive 2002/95/EC (RoHS) & 2011/65/EU (RoHS 2) compliant.
 2. See http://www.diodes.com/quality/lead_free.html for more information about Diodes Incorporated's definitions of Halogen- and Antimony-free, "Green" and Lead-free.
 3. Halogen- and Antimony-free "Green" products are defined as those which contain <900ppm bromine, <900ppm chlorine (<1500ppm total Br + Cl) and <1000ppm antimony compounds.

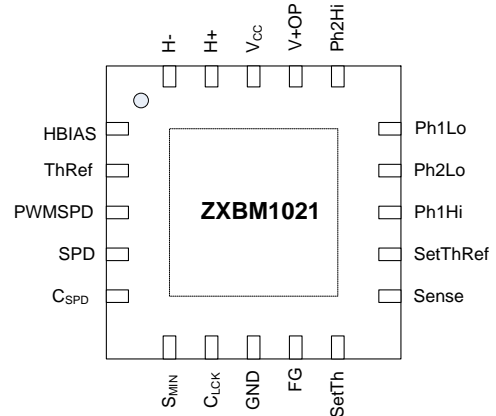
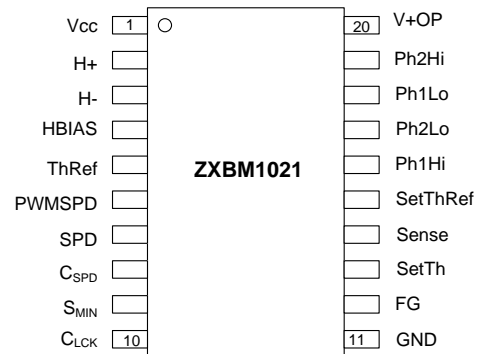
Pin Assignments
(Top View)

U-QFN4040-20
(Top View)

QSOP-20
Applications

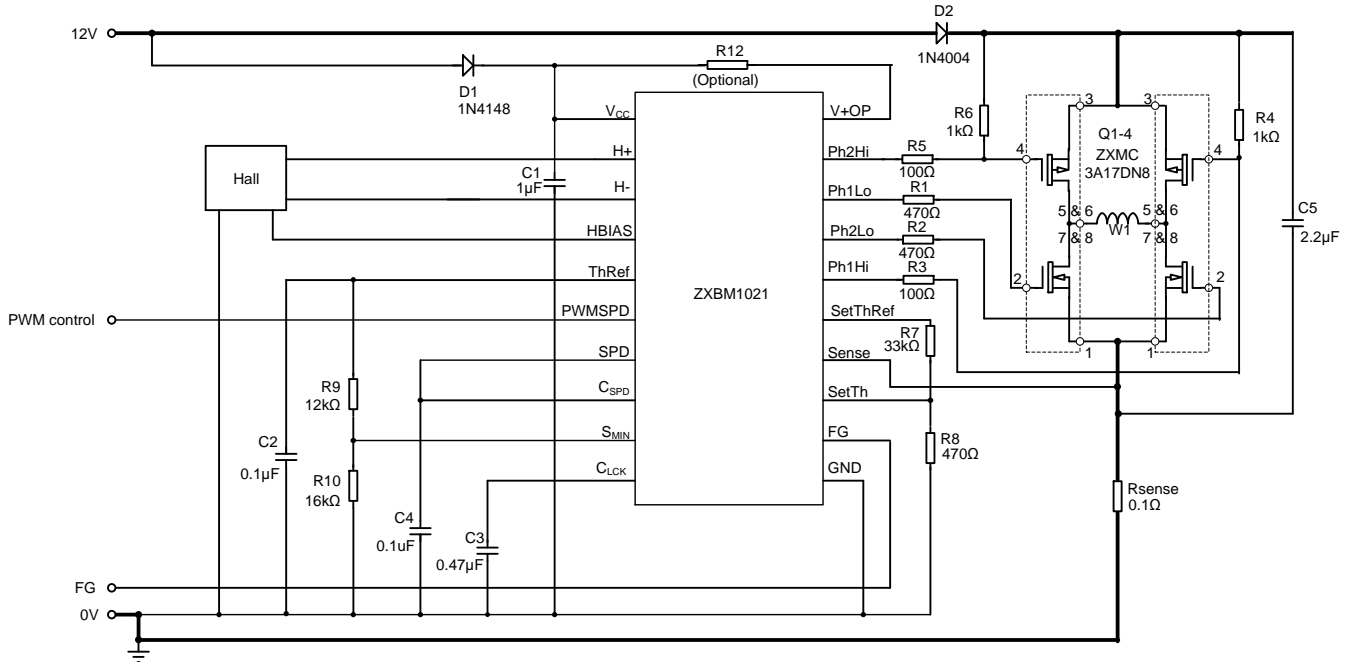
- Personal, servers and mainframe computers cooling fans
- Instrumentation and equipment cooling fans
- Home appliance fans and blowers
- Central heating blowers and extraction systems
- Industrial fans, blower and extractors
- Hand dryers
- Hand-held power tools
- Pumps

Typical Applications Circuit (Note 4)

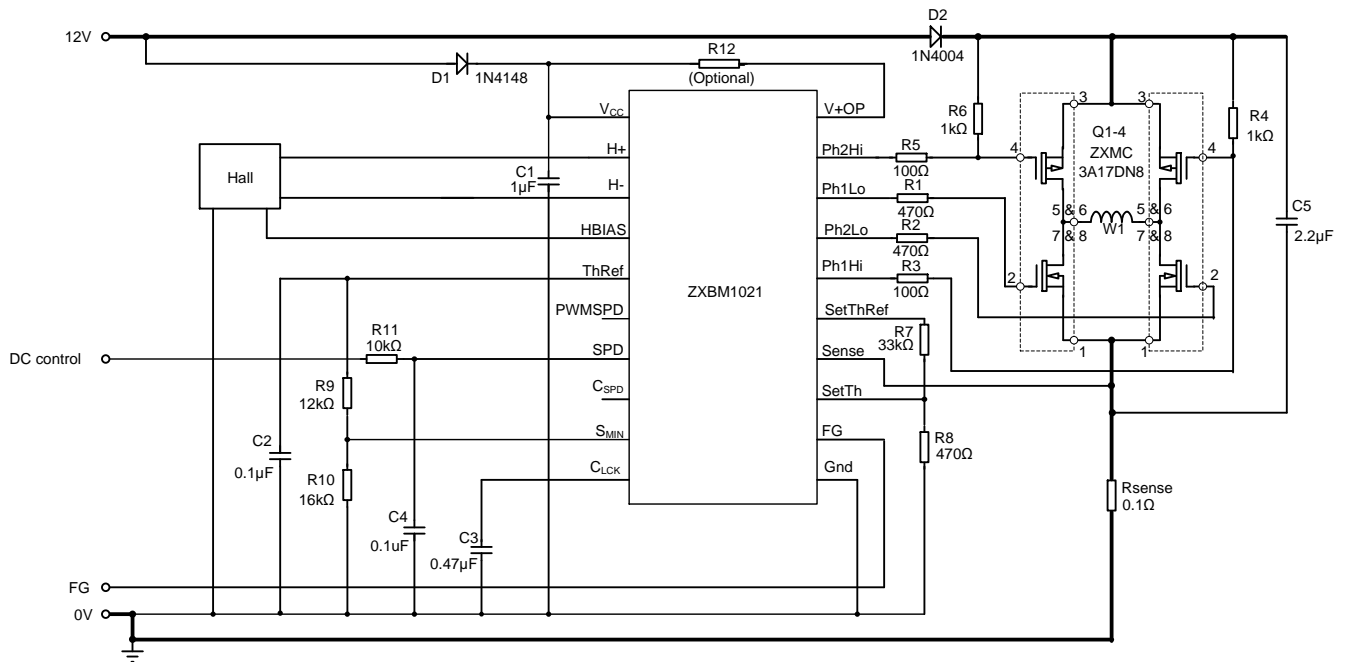

Typical Applications Circuit for PWM Control
using the ZXBM1021 and ZXMC MOSFET 1/2 Bridge Drivers



Typical Applications Circuit for DC Control
using the ZXBM1021 and ZXMC MOSFET 1/2 Bridge Drivers

Note: 4. FG pull-up resistor is not shown in the typical application circuit. Generally, the FG pull-up resistor is located at the system host end rather than the fan motor PCB.

Pin Descriptions

Package types: U-QFN4040-20 and QSOP-20

Pin Number		Pin Name	Description
U-QFN4040-20	QSOP-20		
1	4	HBIAS	Hall Bias Supply Voltage Output Pin. Output voltage is 1.75V typical to supply the external unbuffered ('naked') Hall element. A resistance can be added in series with Hall element if lower bias voltage is needed.
2	5	ThRef	5V Reference Voltage Output Pin. This voltage is used to supply the external networks.
3	6	PWMSPD	Speed Control PWM Signal Input Pin. PWM signal should be between 0% to 100% duty ratio.
4	7	SPD	DC Voltage Speed Control Input Pin. The control signal voltage should be between 3V for 0% (stop) to 1V for 100% (full speed) speed control. In DC voltage mode, connect a capacitor between SPD and ground.
5	8	C _{SPD}	Output Pin of the PWM Speed Control Input Signal Integrator. In PWM speed control mode, connect a 0.1 μ F capacitor from C _{SPD} pin to ground and connect C _{SPD} pin to SPD pin. In DC voltage speed control mode, leave this pin unconnected.
6	9	S _{MIN}	Minimum Speed Setting Pin. Voltage between 3V to 1V on this pin sets the minimum speed the motor is run at between 0% to full speed. The lowest minimum speed achieved depends on the motor coil design.
7	10	C _{CLK}	Rotor Lock Detect, Auto Restart Timing and Soft-Start Timing Control Pin. Typically a 470nF capacitor is connected to this pin to set the soft-start (to full speed), lock detect and restart timings.
8	11	GND	Supply Return Ground Pin
9	12	FG	Frequency Generator Output to Provide a Tachometer Signal. This is a buffered output from the Hall amplifier.
10	13	SetTh	Current Sense Threshold Setting Pin. Used to set the threshold voltage that represents the maximum current to be taken by the motor. The current sense voltage at Sense pin is compared to the SetTh voltage.
11	14	Sense	Current Sense Pin. Input for the signal from a sense resistor in the ground return of the H-bridge circuit to represent the current taken by the motor.
12	15	SetThRef	A variable voltage source used to set the voltage on the SetTh pin.
13	16	Ph1Hi	Phase 1 High-Side External Power Switch Drive Output Pin. This is a 50mA open-collector output.
14	17	Ph2Hi	Phase 2 High-Side External Power Switch Drive Output Pin. This is a 50mA open-collector output.
15	18	Ph2Lo	Phase-2 Low-Side External Power Switch Drive Output Pin. Darlington emitter follower output with active pull down to give source/sink current of 100mA/100mA.
16	19	Ph1Lo	Phase-1 Low-Side External Power Switch Drive Output Pin. Darlington emitter follower output with active pull down to give source/sink current of 100mA/100mA.
17	20	V+OP	Phase Low Output Supply Pin. Only the low side output drives for Ph1Lo and Ph2Lo are supplied by the V+OP pin. For external MOSFET power devices, a resistor from V _{CC} pin to V+OP slows down the turn-on speed of the low-side MOSFET S and therefore helps prevent shoot-through during turn-on of low-side switches. For external Bipolar power devices, a resistor between the V _{CC} pin and V+OP controls the current into the transistor base.
18	1	V _{CC}	Power Supply Pin
19	2	H+	Hall Device Positive Input Pin. When H+ is higher in relation to H-, Ph2 is active.
20	3	H-	Hall Device Negative Input Pin

Functional Block Diagram (Note 5)

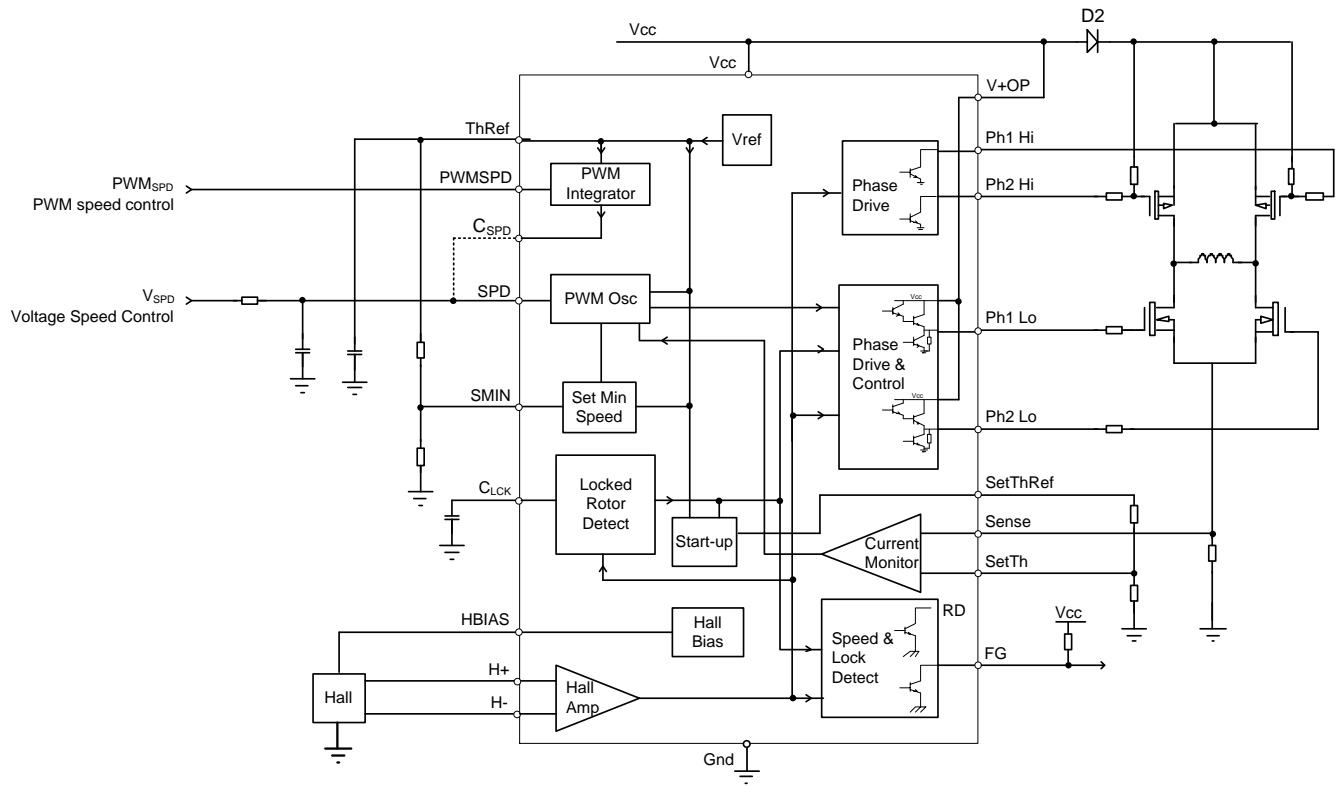

Note: 5. The ZXBM1021 has an open-collector FG. Typically a pull-up resistor of 10kΩ is recommended from FG pin to the supply voltage.

Absolute Maximum Ratings (Note 6) @ $T_A = +25^\circ\text{C}$, unless otherwise specified.)

Symbol	Characteristics	Values	Unit	
V_{CCMAX}	Supply Voltage (Note 7)	-0.6 to 20	V	
I_{CCMAX}	IC Input Current	200	mA	
P_{DMAX}	Power Dissipation (See thermal de-rating curve on 'Thermal Performance' section)	U-QFN4040-20	820	mW
		QSOP-20	820	mW
T_{ST}	Storage Temperature Range	-55 to +150	$^\circ\text{C}$	
T_J	Maximum Junction Temperature	150	$^\circ\text{C}$	
ESD HBM	Human Body Model (HBM) ESD Capability	2	kV	
ESD MM	Machine Model (MM) ESD Protection	300	V	

- Notes:
- Stresses greater than the 'Absolute Maximum Ratings' specified above may cause permanent damage to the device. These are stress ratings only; functional operation of the device at these or any other conditions exceeding those indicated in this specification is not implied. Device reliability may be affected by exposure to absolute maximum rating conditions for extended periods of time.
 - The absolute maximum V_{CC} of 20V is a transient stress rating and is not meant as a functional operating condition. It is not recommended to operate the device at the absolute maximum rated conditions for any period of time.

Recommended Operating Conditions

Symbol	Characteristic	Conditions	Min	Max	Unit
V_{CC}	Supply Voltage	Operating, -40°C to $+110^\circ\text{C}$	6.8	18.0	V
T_A	Operating Temperature Range	Operating	-40	+110	$^\circ\text{C}$

Electrical Characteristics (@ $T_A = +25^\circ\text{C}$, $V_{DD} = 12\text{V}$, unless otherwise specified.)

Symbol	Characteristics	Conditions	Min	Typ	Max	Unit
I_{CC}	Supply Current	No Load (Note 8)	—	10	15	mA
Hall Connections						
V_{IN}	Hall Amplifier Input Voltage	Diff peak to peak	40	—	—	mV
V_{CM}	Hall Amplifier Common Mode Voltage		0.5	—	V_{ThRef}	V
V_{HYS}	Hall Amplifier Input Hysteresis		—	± 12	—	mV
I_{BS}	Hall Amplifier Bias Current		—	700	1000	nA
V_{HB}	Hall Bias Voltage	$I_{HB} = 10\text{mA}$	1.5	1.75	1.95	V
I_{HB}	Hall Bias Output Current Capability		—	—	10	mA
Reference Voltage						
V_{ThRef}	ThRef Reference Output Voltage	$I_{OThRef} = 10\text{mA}$, $+25^\circ\text{C}$	4.85	5	5.15	V
		$I_{OThRef} = 10\text{mA}$, -40°C to $+110^\circ\text{C}$	4.75	5	5.25	V
I_{OThRef}	ThRef Output Current Capability		—	—	10	mA
PWM Oscillator						
F_{PWM}	PWM Frequency		18	25	—	kHz
DC Voltage Speed Control						
V_{SPDL}	SPD Voltage Minimum	100% PWM drive	—	1	—	V
V_{SPDH}	SPD Voltage Maximum	0% PWM drive	—	3	—	V
I_{SPD}	SPD Pin Current at speed demand of 50% of the full speed and without minimum speed setting	$V_{SPD} = 2\text{V}$ $S_{MIN} = 0\text{V}$	—	0.5	2	μA
$I_{SPD_S_{MIN}2\text{V}}$	SPD Pin Current with minimum speed setting of 50% of the full speed	$V_{SPD} = 3\text{V}$ $R_{SPD} = 10\text{k}\Omega$ $S_{MIN} = 2\text{V}$	—	100	—	μA
L_{inSPD}	SPD Pin voltage to output PWM linearity	$V_{SPD} = 2\text{V}$	—	—	3	%

Note: 8. Measured with pins H+, H-, C_{LCK} and C_{PWM} and all other signal pins open circuit.

Electrical Characteristics (cont.) (@T_A = +25°C, V_{DD} = 12V, unless otherwise specified.)

Symbol	Characteristics	Conditions	Min	Typ	Max	Unit
PWM Speed Control						
V _{PWMSPDH}	PWMSPD High Level		2		V _{CC}	V
V _{PWMSPDL}	PWMSPD Low Level				0.4	V
I _{PWMSPD}	PWMSPD High Level Input Current			0.8	2	μA
D _{PWMSPD}	PWM Speed Signal Duty Range		0		100	%
F _{PWM_MAX}	Maximum Frequency of PWM Control Signal				100	kHz
L _{inINT}	PWMSPD Pin PWM Duty Ratio to C _{SPD} Output Voltage Linearity	PWMSPD duty ratio 50%, PWM frequency F _{PWM} = 25kHz	1.94	2	2.06	V
Minimum Speed Setting						
I _{SMIN}	S _{MIN} Input Current	V _{SMIN} = 2V		-0.25	-0.5	μA
Soft Start						
t _{SS}	Soft-Start Time to Full Speed	C _{CLK} = 0.47μF		3		s
Lock Timing						
	Lock Condition T _{LCKDET} : T _{OFF} ratio			1:8		
I _{LCKCL}	C _{CLK} Charge Current – Soft Start (from lock) and in Lock Mode	Lock mode, V _{CLK} = 2.5V	0.45	0.7	1.07	μA
I _{LCKCR}	C _{CLK} Charge Current – Run	Run mode	3.25	5.5	9.0	μA
I _{LCKDL}	C _{CLK} Discharge Current - Lock	Lock mode, V _{CLK} = 2.5V	0.45	0.7	1.07	μA
V _{CLKTHH}	C _{CLK} High Threshold Voltage			5		V
V _{CLKTHL}	C _{CLK} Low Threshold Voltage	Lock mode		0.6		V
Current Limit						
V _{SetThRef}	SetThRef Output Voltage	I _{SetThRef} = 200uA	ThRef-0.17	ThRef-0.1V	ThRef-0.05	V
I _{SetThRef}	SetThRef Output Current				-200	μA
I _{SENSE}	Sense Input Current			-20	-100	nA
I _{SetTh}	SetTh Input Current			-20	-100	nA
Output Drives						
V _{OH}	Ph1Lo and Ph2Lo Output High Voltage	I _{OH} = 100mA	V _{CC} - 2.2	V _{CC} - 1.7		V
V _{OLA}	Ph1Lo and Ph2Lo Output Low Voltage	I _{OL} = 100mA (Note 9)		0.3	0.5	V
V _{OLB}	Ph1Lo and Ph2Lo Output Low Voltage	I _{OH} = 50μA (Note 10)		0.3	0.5	V
I _{OH}	Ph1Lo and Ph2Lo Output Source Current				100	mA
I _{OL}	Ph1Lo and Ph2Lo Output Sink Current				100	mA
V _{OLA}	Ph1Hi and Ph2Hi Output Low Voltage	I _{OH} = 50mA (Note 10)		0.3	0.5	V
I _{OL}	Ph1Hi and Ph2Hi Output Sink Current				50	mA
I _{OFF}	Ph1Hi and Ph2Hi Off Output Leakage Current				±100	nA
t _{CD}	Commutation Delay		20	70		μs
Output Flags						
I _{FGOL}	FG Low Level Output Current Capability				10	mA
V _{FGOL}	FG Low Level Output Voltage	I _{FGOL} = 10mA			0.4	V
Lock Conditions						
T _{LCKDET}	Lock Detect Time (time it waits for before next Hall signal before deciding to turn outputs off for fixed time)	C _{CLK} = 0.47μF I _{LCKCR} = 5.5μA		400		ms
T _{OFF}	Output Off Time after lock is detected.	C _{CLK} = 0.47μF		3		s

Notes: 9. Measured when opposing Phase Output is Low.
10. Measured when opposing Phase Output is High.

Functional Descriptions

H-Bias – Hall Bias Output

This is a 1.75V nominal voltage source to bias a differential un-buffered Hall element sensor. If a Hall element requires a lower voltage than the H-Bias output, connect an appropriate value resistor between the H-Bias pin and the Hall element supply pin.

H+ and H- – Hall Inputs

The rotor position is detected by a Hall sensor, with the output applied to the H+ and H- pins. This sensor can be either a 4 pin 'naked' Hall device or of the 3 pin buffered switching type. For a 4 pin device the differential Hall output signal is connected to the H+ and H- pins. For a buffered Hall sensor the Hall device output is attached to the H+ pin, with a pull-up attached if needed, whilst the H- pin has an external potential divider attached to hold the pin at half V_{ThRef} . When H+ is high in relation to H-, Ph2 is the active drive.

ThRef – Output Reference Voltage

This is a 5V nominal reference output voltage. It is designed to 'source' current and therefore it will not 'sink' any current from a higher voltage. The total current drawn from the ThRef pin by any external circuitry, such as the minimum speed potential divider to S_{MIN} pin, should not exceed 10mA.

SPD –Speed Control DC Voltage Input

The voltage applied to the SPD pin provides control over the fan motor speed by varying the Pulse Width Modulated (PWM) drive ratio at the Ph1Lo and Ph2Lo outputs. The control signal takes the form of a variable DC voltage input of range 3V to 1V, representing 0% to 100% drive respectively.

If variable speed control is not required this pin can be tied to an external potential divider to set a fixed speed or tied to ground to provide full speed i.e. 100% PWM drive.

If required this pin can also be used as an enable pin. The application of a voltage >3.0V on this pin will force the PWM drive fully off, in effect disabling the drive, providing the minimum speed function is not active (see S_{MIN} pin section below).

To use a minimum speed setting or current control in DC voltage speed control mode, add a series resistor 10k Ω or greater (R11 in typical application circuit for DC control in page 2) between speed control DC voltage input source and SPD pin.

PWMSPD – Speed Control PWM Signal Input

The duty ratio of the speed control PWM signal input to this pin controls the fan motor speed by varying the output drive PWM ratio at the Ph1Lo and Ph2Lo outputs. In the PWM speed control mode, the PWMSPD pin and the C_{SPD} pin work together to control the speed. The PWM signal input on the PWMSPD pin is integrated by the capacitor on the C_{SPD} pin (See C_{SPD} pin description). PWM control input signal to the PWMSPD pin needs to be a TTL logic levels.

C_{SPD} – PWM Speed Control Signal Integrator Output

When PWM input signal is used to control the motor speed, PWM signal is integrated to DC voltage between 1V to 3V to for speed control. If PWMSPD pin input is TTL low, the output voltage on C_{SPD} is 3V and if PWMSPD pin is TTL high, the C_{SPD} pin output is at 1V. In order for the integrator function to be fulfilled an external capacitor is required. This would normally be a 0.1 μ F capacitor for a 25kHz input PWM frequency applied to the PWMSPD input.

In PWM speed control mode, connect 0.1 μ F capacitor from C_{SPD} pin to ground and connect C_{SPD} pin to SPD pin. When in DC voltage speed control mode keep PWMSPD and C_{SPD} pins unconnected.

S_{MIN} – Minimum Speed Setting

A voltage can be set on this pin via a potential divider between the ThRef and GND pins. This voltage is monitored by the SPD pin to clamp the SPD control voltage so that it does not rise above S_{MIN} voltage. As a higher voltage on the SPD pin represents a lower speed, the S_{MIN} setting prevents the motor speed going lower than the minimum speed set by the S_{MIN} pin. If this feature is not required the pin is left tied to ThRef so no minimum speed will be set.

If the fan is being controlled from an external voltage source onto the SPD pin then either this feature should not be used or if the minimum speed setting is required then a 10k Ω or greater resistor should be placed in series with the SPD pin.

Functional Descriptions (cont.)

C_{LCK} – Locked Rotor Timing Capacitor

The C_{LCK} pin will have a capacitor connected to ground. It is a multi-function pin providing timing for the lock detect, auto-restart and soft-start conditions. Different rates of charge and discharge of C_{LCK} capacitor depending on the mode of operation (fan operation status) give the soft-start (T_{SS}) to full speed, lock-detect time (T_{LCKDET}) and lock time (T_{OFF}) before next auto-start retry. When the motor is running, the capacitor is discharged at every Hall signal change.

C_{LCK} pin provides the timing for the Locked Rotor monitor. In normal operation, and after the soft-start period, Lock Detect is enabled. If the Hall signal does not change (i.e. a rotor lock condition) within the Lock Detect time (T_{LCKDET}), the outputs are disabled. In this condition the motor will not be driven for a set time T_{OFF}. This T_{OFF} time depends on the external C_{LCK} capacitor value and its internal discharge current (I_{LCKDL}). After the T_{OFF} period device goes into a soft-start period (T_{SS}) to re-start the motor. If the motor has not turned to generate a transition on the Hall inputs by the end of this period, motor re-enters motor lock T_{OFF} period with outputs disabled. Once the fan is running normally at the end of a soft-start period, the motor is deemed as running and goes into lock-detection mode.

The time periods of T_{SS}, T_{LCKDET} and T_{OFF} are determined by the value of the external capacitor on the C_{LCK} pin and the internal charge and discharge currents during these time periods. The currents during T_{SS}, T_{LCKDET} and T_{OFF} are I_{LCKCL}, I_{LCKCR} and I_{LCKDL} respectively.

During soft-start mode, the SetThRef voltage is increased from 0 to Vref. A potential divider from SetThRef is used to generate SetTh voltage for current limit. As SetThRef ramps to nominal value, current limit set also ramps from 0 to nominal setting. This gradual release of current limit to full speed level provides the soft-start.

FG – Frequency Generator (Tachometer) Output

This is the Frequency Generator output and is a buffered signal from the Hall sensor. This is an open collector drive giving an active pull down with the high level being provided by an external pull up resistor.

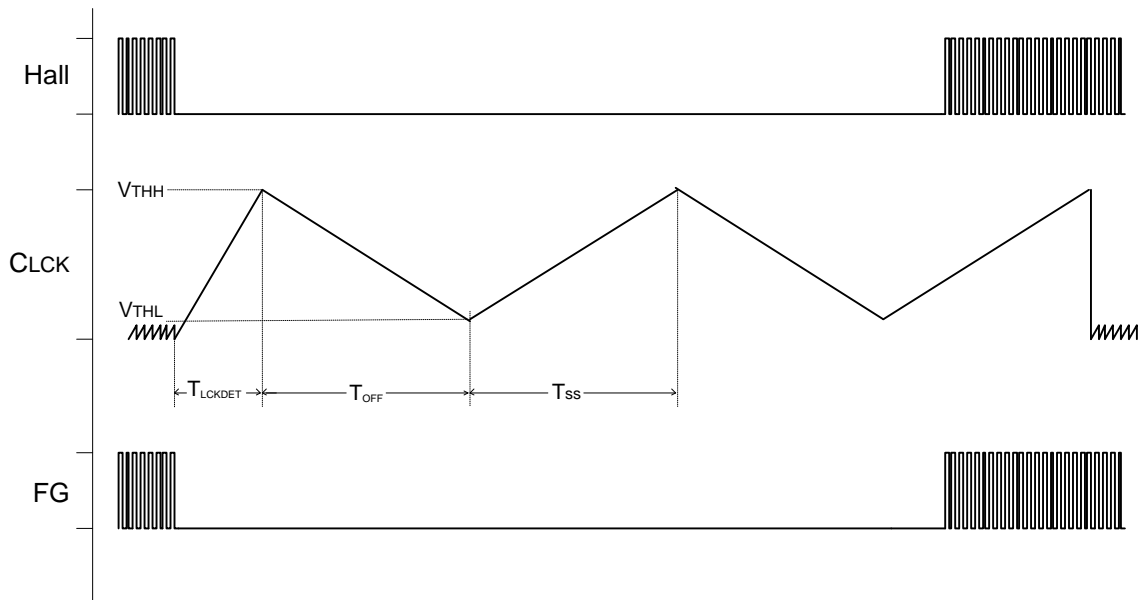

FG Timing Diagram

Functional Descriptions (cont.)

Sense – Current Control Sense

This pin is used by the current sensing circuit to monitor the current taken by the motor windings. The signal comes from a sense resistor in the low-side ground return of the external H-bridge driver.

SetTh – Current Control Threshold Voltage

This pin is used by the current sensing circuit as the reference voltage for the voltage on the sense pin to be compared against. If the voltage on the sense pin starts to exceed the voltage set on this pin the current control circuitry starts to back off the output drive PWM duty and thus reducing the current being supplied to the motor coil.

SetThRef – SetTh and Start-up Reference

This pin is derived from an internal start-up circuit and is used as the source voltage for the potential divider network attached to the SetTh pin. Under running conditions this voltage will be typically ThRef-0.1V. However, during start up the voltage ramps up from 0V to ThRef-0.1V at a rate determined by the capacitor on the C_{LCK} pin giving a gradual release of current limit from 0 to nominal setting. ThRef-0.1V is equal to 4.9V typical.

This low power pin is capable of supplying a maximum of 200µA. It should only be used to supply the potential divider network attached to the SetTh pin.

Ph1Lo and Ph2Lo – Low-Side External H-Bridge Drive Output

Ph1Lo and Ph2Lo outputs drive the low side of the external power device H-bridge that in turn drives the single phase winding. These outputs provide both the commutation and PWM waveforms. The outputs are active pull-up and active pull-down to help faster switching off when driving MOSFET devices with a high gate capacitance. When in the high state the outputs will provide up to 100mA of drive into the base or gates of external transistors as shown in the typical application circuit shown on the front page.

When in the low state the active phase drive is again capable of sinking up to 100mA to aid turn off times during PWM operation. When the phase is inactive the output is held low by a 7.5kΩ internal pull-down resistor.

Ph1Hi and Ph2Hi – High-Side External H-Bridge Driver

Ph1Hi and Ph2Hi are the high side outputs to the external H-bridge and are open collector outputs capable of sinking 50mA. This signal provides commutation only to the H-bridge.

V+OP – Phase Outputs Supply Voltage

This pin is the supply to the Phase outputs Ph1Lo and Ph2Lo only. This pin can be connected to V_{CC} pin directly or through a resistor. For external Bipolar power devices the resistor on V+OP is used to control the current into the transistor base and its value is chosen accordingly. For external MOSFET power devices, the pin can be used to slow down the turn-on speed of the low-side MOSFETS. Slowing down the turn-on speed of low side switches helps to prevent parasitic turn-on of the high-side switches and thus helping to prevent shoot-through during turn-on of low-side switches. The gate resistor connected at Ph1Lo and Ph2Lo plus the resistor on V+OP controls the turn on speed of the MOSFET. The turn-off of speed of the MOSFETS is controlled by the gate resistor only.

V_{CC} – IC Supply voltage

This provides the supply for the device's internal circuitry except Ph1Lo and Ph2Lo output stages, which are supplied from the V+OP pin.

For 12V fans this can be supplied directly from the Fan Motor supply. For fans likely to run in excess of the 18V maximum rating for the device this will be supplied from an external regulator such as a Zener diode or low drop out regulator.

GND – Supply Return

This is the device supply ground return pin and will generally be the most negative supply pin to the fan.

Typical Operating Characteristics

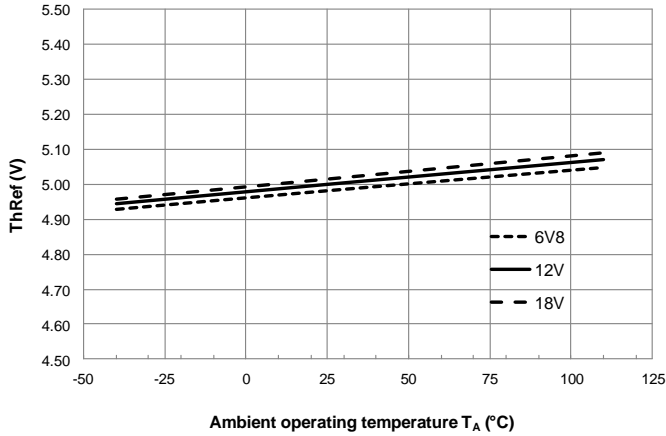

Ambient operating temperature T_A (°C)

ThRef vs Ambient Temperature

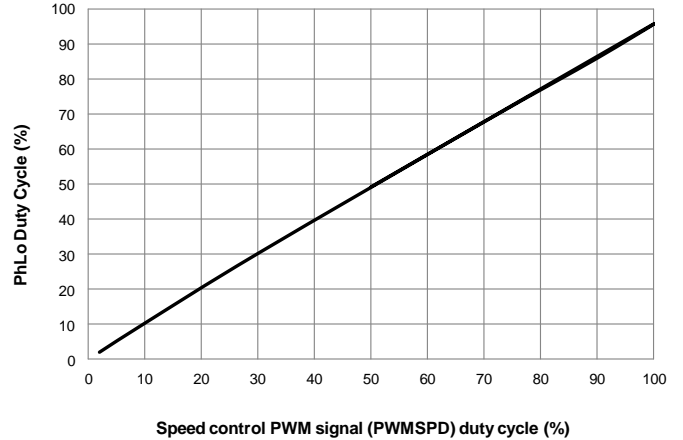

Speed control PWM signal (PWMSPD) duty cycle (%)

PhLo Output Duty Cycle vs. Speed Control PWM Signal (PWMSPD) Duty Cycle

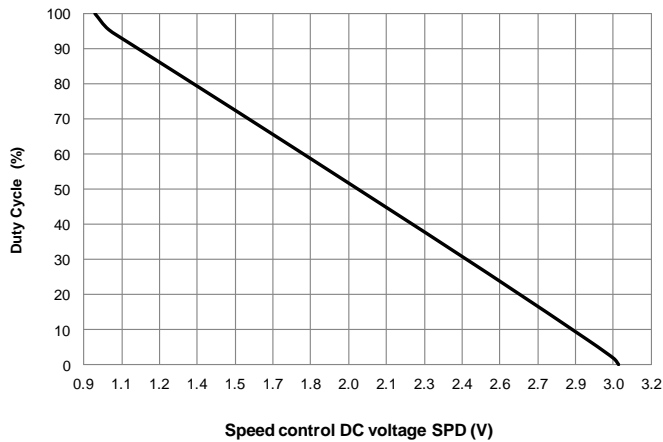

Speed control DC voltage SPD (V)

PhLo Output Duty Cycle vs Speed control DC Voltage (SPD)

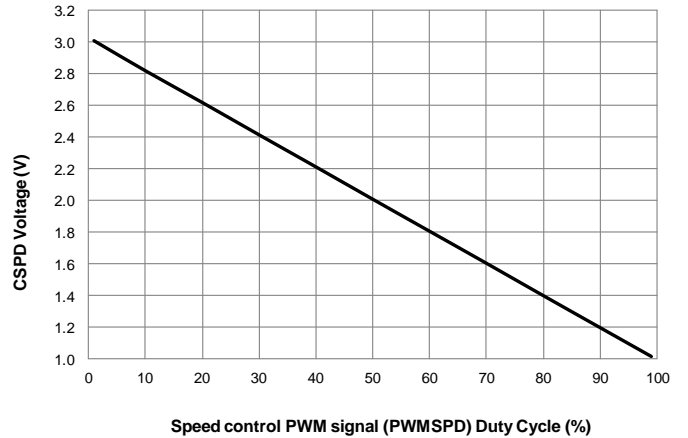

Speed control PWM signal (PWMSPD) Duty Cycle (%)

CSPD Voltage vs Speed Control PWM Signal (PWMSPD) Duty Cycle

Application Information

The ZXBM1021 is primarily controlled by a voltage on the SPD pin or a PWM signal on the PWMSPD pin.

A voltage of 1V represents a 100% PWM at the Phase Outputs and in turn represents full speed. 3V on the SPD pin conversely represents 0% PWM. The motor can therefore be controlled simply by applying a control voltage onto the SPD pin with the minimal use of external components.

This voltage control method easily lends itself to control by other signal types. For example if a thermistor is applied to the SPD pin a varying voltage can be generated at the SPD pin as the resistance of the thermistor varies with temperature.

A common form of control of fans is by a PWM signal derived from a central processor or controller. This speed control PWM signal can be applied to PWMSPD pin. Motor speed is proportional to the duty ratio of the applied PWM speed control signal on PWMSPD pin.

Voltage on the S_{MIN} pin sets the minimum speed of the motor. If the speed demand by either DC signal on SPD pin or PWM signal on PWMSPD pin is lower than the minimum speed setting, motor will run at minimum speed.

The design of a motor system will be set around the maximum speed, the minimum speed and the current of the motor. The design of the motor coil and the voltage on the output stage will set the maximum speed of the motor.

The ZXBM1021 allows easy setting and control of the minimum speed and maximum motor current, as well as for controlling the speed.

DC Speed Control

The SPD pin will respond to an input DC voltage from 3V to 1V for 0% to 100% of the full speed. To allow internal minimum speed setting (S_{MIN}) and current control (ILIM) circuits to adjust the SPD pin voltage, the speed control DC voltage signal should be driven in via a 10kΩ series resistor. The series resistor allows the SPD pin to vary even when driven externally by a low impedance source. A 0.1μF capacitor should be connected from the SPD pin to supply ground.

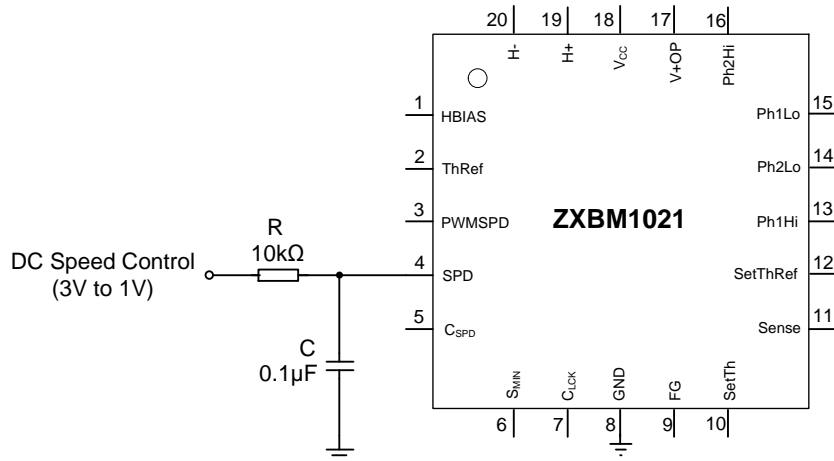

When used in DC speed control mode, PWMSPD and C_{SPD} pins should be left floating.

Application Information (cont.)

This input also allows the fan to be driven by a thermistor, to allow the speed to be controlled according to temperature. An example circuit is shown below.

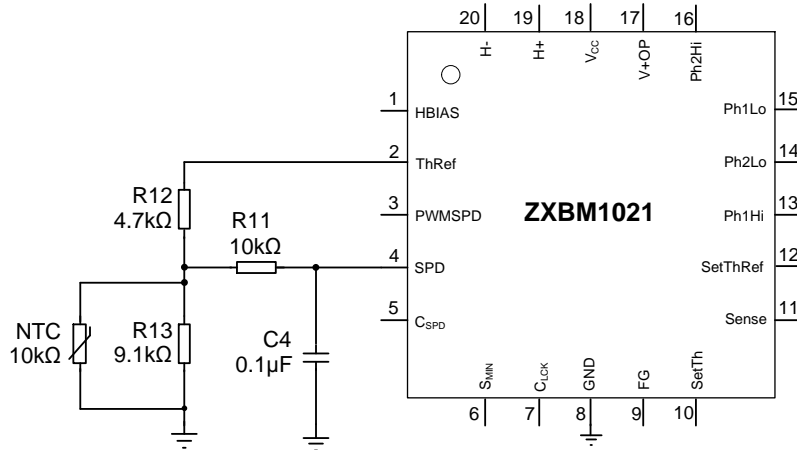

With the values shown, and a Beta value of 4000 for the NTC, the above circuit drives the ZXBM1021 with 3V (minimum speed) at 0°C, changing to 1V (maximum speed) at 82°C, subject to tolerances. To minimize additional circuitry, the 5V ThRef output from the ZXBM1021 IC can supply the current required for the thermistor network circuit as long as the total current from ThRef does not exceed 10mA.

PWM Speed Control

An additional input allows for the use of PWM to control the fan speed. The ZXBM1021's output speed is proportional to the duty cycle of the PWM input.

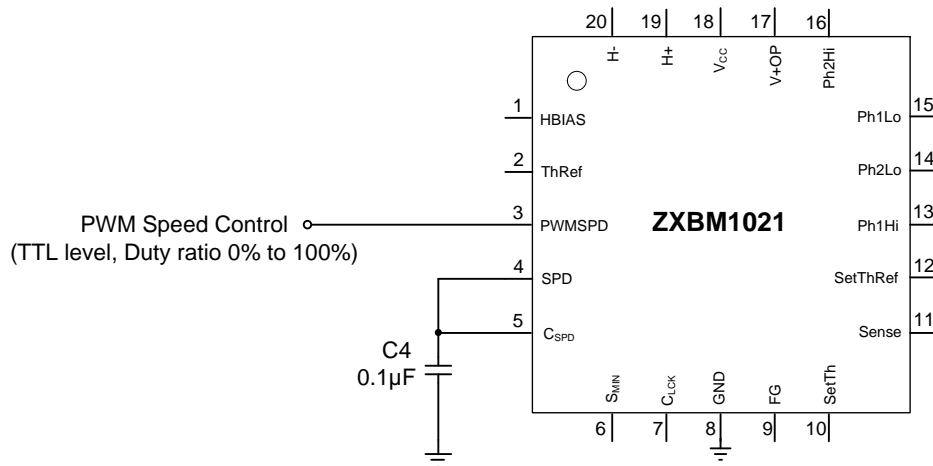

When using PWMSPD speed input, the SPD pin should be connected to CSPD with a 0.1µF capacitor connected to ground. PWMSPD can be driven from a microcontroller with either 0-5V or 0-3.3V logic levels signal. The recommended frequency of the input PWM control signal is 25kHz.

Application Information (cont.)

S_{MIN} Minimum Speed Setting

Minimum speed setting prevents the motor from running below a set speed regardless of whether the control applied is for a slower speed (either DC or PWM input). The minimum motor speed is chosen based on a speed below which the motor may or fail to start.

The S_{MIN} pin voltage sets a maximum voltage clamp for the SPD pin.

For a DC voltage input into SPD pin, the voltage range 3V to 1V represents 0% to 100% of full speed. In order to set a minimum speed of 20%, S_{MIN} should be set 20% into this range below 3V, i.e. 2.6V.

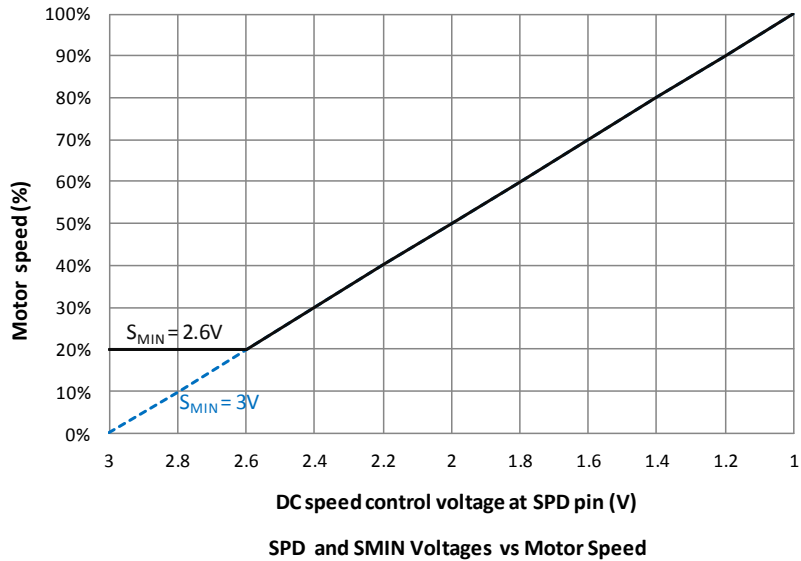

Minimum speed is set by the voltage on the S_{MIN} pin, using a potential divider from the ThRef voltage output as shown below.

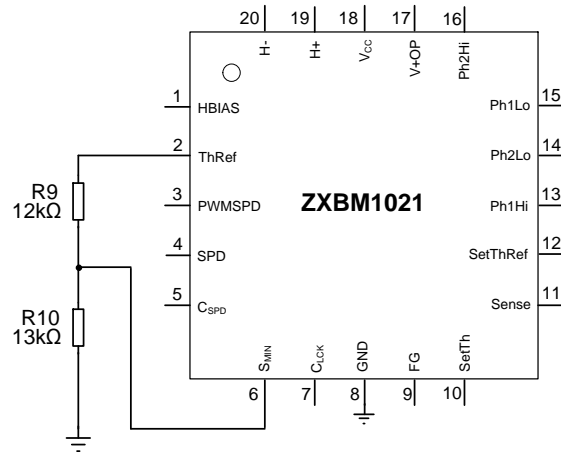

The S_{MIN} voltage is given by

$$S_{MIN} = ThRef \left(\frac{R10}{R9 + R10} \right)$$

Application Information (cont.)

ThRef is capable of driving 10mA, but it is not necessary to draw much current for S_{MIN}. Set R10+R9 in the range 5kΩ-50kΩ (1mA - 100μA).

ThRef may also be used to drive a thermistor circuit, so care must be taken to keep the total current drawn from ThRef to the correct level.

Example: Required S_{MIN} of 20% = 2.6V

$$S_{MIN} = ThRef \left(\frac{R10}{R9+R10} \right)$$

$$2.6V = 5V \left(\frac{R10}{R9+R10} \right)$$

Solve for R9

$$R9 = \left(\frac{2.4}{2.6} \right) R10$$

Choose R10 = 13kΩ and solve for R9 which gives R9 = 12kΩ. The current in R10+R9 string = 5/25000 = 200μA

If S_{MIN} is not required, the S_{MIN} pin should be pulled up externally to ThRef by 1kΩ

Motor Current Limit

The motor current limit on ZXBM1021 compares the voltage on the Sense pin against the threshold voltage on the SetTh pin. The current limit is triggered when the voltage at the Sense pin exceeds the threshold at SetTh. The device lowers the output PWM drive duty ratio if the voltage on the Sense pin rises above the threshold voltage on the SetTh pin.

The threshold value at SetTh pin is set using R7 and R8 between SetThRef, SetTh and GND. The Sense voltage is generated by the motor current flowing through the sense resistor. It is recommended to use 100mΩ for the sense resistor on the Sense pin, and vary the current limit by changing R7 and R8.

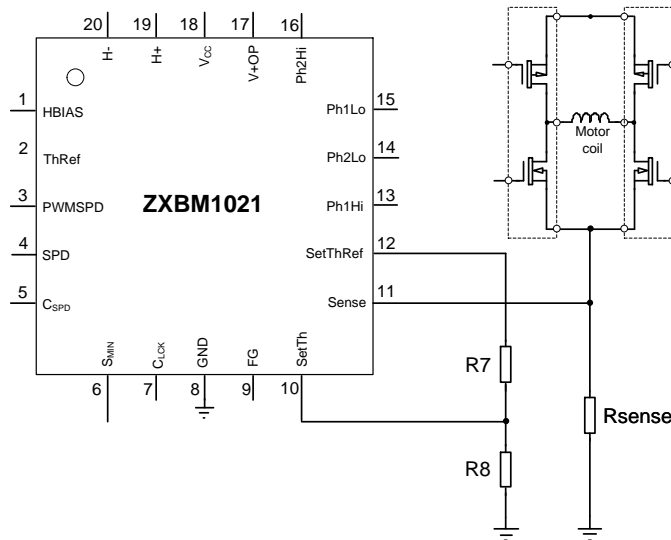

The current limit, I_{LIM}, is given by

$$I_{LIM} = \frac{SetThRef \frac{R8}{R7 + R8}}{R_{SENSE}}$$

Note that SetThRef has a maximum output current of 200μA, therefore R7+R8 must be larger than 25kΩ.

Application Information (cont.)

Example: Required $I_{LIM} = 2A$

$$I_{LIM} = \frac{\text{SetThRef} \frac{R8}{R7 + R8}}{R_{SENSE}}$$

where $\text{SetThRef} = (\text{ThRef} - 0.1V) = 4.9V$ typical

$$2A = \frac{4.9V \frac{R8}{R7 + R8}}{0.1\Omega}$$

Solve for R7

$$R7 = \left(\frac{4.9}{0.2}\right) R8$$

Choose $R8 = 2k\Omega$ and solve for R7 which gives $R7 = 47k\Omega$.

The current in R7+R8 string = $4.9/49000 = 100\mu A$ which is within maximum output current capability of the SetThRef pin.

It is important that the current limit be set above the intended average current of the motor. In practice, due to the variable nature of the motor current through a commutation cycle, it is usually necessary for the current limit to be set higher than the peak current drawn at the beginning of each commutation cycle.

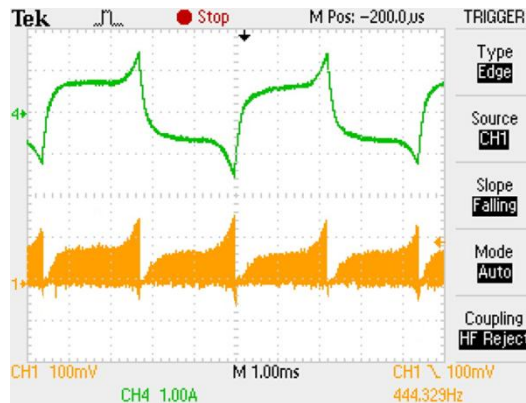

The top trace shows the motor coil current, while the lower trace shows the Sense pin voltage. As the current flow direction in the motor coil changes at each commutation cycle, the motor current in the top trace is shown as positive and negative current. The current flowing in the Rsense is always in the same direction and therefore the sense pin reads the magnitude of the motor coil current.

Current limiting may prevent the motor from reaching full speed, despite the average current being significantly lower than the current limit. The system will limit the tail-end current according to the current limit set. Current limit setting can also be used to remove the tail-end current. Example of using current limit to reduce tail-end current at full speed is shown in fibelow

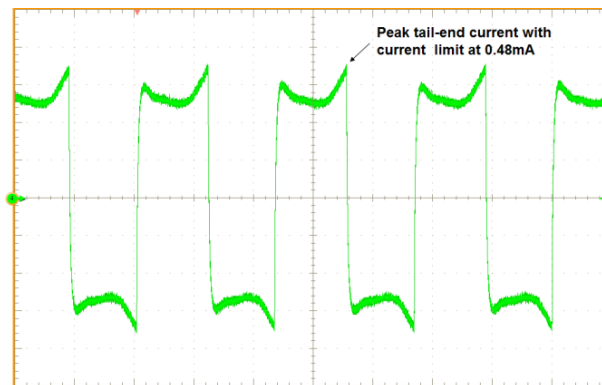

Current limit set much higher than the peak tail-end current (Peak tail-end current = 180mA typ, Current limit set at 0.485mA)

Application Information (cont.)

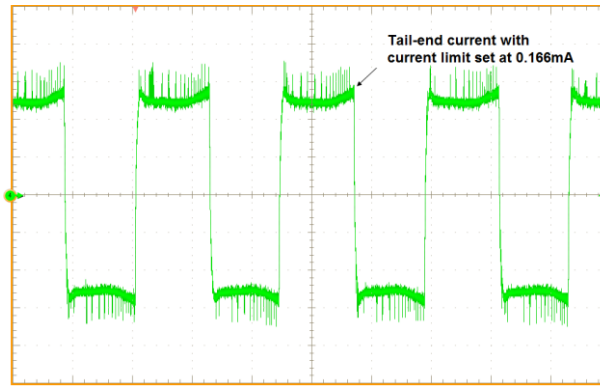

Current limit set lower than the peak tail-end current
(Tail-end current = 145mA typ, Current limit set at 0.166mA)

C_{LCK} Value

The value of C_{LCK} affects three important timings for the ZXBM1021: Soft Start, Lock Detect and Off-time.

Soft Start

When the system is initially powered on, it will go through the soft-start period, during which the motor is gradually ramped to full speed. The soft start operation relies on the current control feature being implemented and generally the current limit is set slightly above the normal running current.

In the soft start process, at power-on the voltage at C_{LCK} will rapidly increase to the low threshold, V_{CLCKTHL} (0.6V). Then, C_{LCK} will be charged from 0.6V up to the high threshold, V_{CLCKTHH} (5V) at a constant current, I_{LCKCL}, which is typically 0.7µA. The time taken to charge the capacitor from V_{CLCKTHL} to V_{CLCKTHH} level depends on the value of C_{LCK} capacitor. The soft-start time t_{SS} is given by:

$$t_{SS} = \frac{C_{LCK} (V_{CLCKTHH} - V_{CLCKTHL})}{I_{LCKCL}}$$

Since V_{CLCKTHH}, V_{CLCKTHL} and I_{LCKCL} are fixed, this becomes simply:

$$t_{SS} = C_{LCK} \times 6.29 \times 10^6$$

For the default value of C_{LCK}, 0.47µF, soft-start time is:

$$t_{SS} = 0.47 \times 10^{-6} \times 6.29 \times 10^6 = 0.47 \times 6.29 = 2.96s$$

This is the 3s stated in the datasheet electrical parameter section.

Lock Detect

When the motor is running, the hall sensor will follow the rotor magnetic flux density to detect the commutation point. Should the rotor lock, the signal from the hall sensor will cease. The value of C_{LCK} defines the lock detect time period before the ZXBM1021 shuts down the outputs in order to prevent damage to the coil.

The ZXBM1021 internal system returns C_{LCK} voltage to the low threshold, V_{CLCKTHL} (0.6V), each time the hall sensor provides a commutation signal. C_{LCK} then charges at the run current, I_{LCKCR}, which is typically 5.5µA. If the voltage on C_{LCK} reaches the high threshold, V_{CLCKTHH} (5V), before the hall sensor provides the next commutation signal then the system will shut down by entering the lock condition.

$$t_{LCKDET} = \frac{C_{LCK} (V_{CLCKTHH} - V_{CLCKTHL})}{I_{LCKCR}}$$

The thresholds voltage and charge current are fixed, therefore the time depends only on the value of C_{LCK}:

$$t_{LCKDET} = C_{LCK} \times 0.8 \times 10^6$$

For the default value of C_{LCK}, 0.47µF, t_{LCKDET} is as follows:

$$t_{LCKDET} = 0.47 \times 10^{-6} \times 0.8 \times 10^6 = 0.47 \times 0.8 = 0.376s$$

This should not interfere with normal operation of a fan as the time period for lock detection is many times longer than the expected time for one revolution. As the hall sensor will detect 4 transitions in a single revolution, 0.376s between transitions would equate to a rotational speed of 40rpm. For use in systems where extremely low rotation speeds are required, the lock detect time can be increased by making the C_{LCK} capacitor value larger.

Application Information (cont.)

Off Time

If the above lock detection causes a device shutdown, C_{LCK} is used again to provide the time period, t_{OFF}. This is the time for which the device will remain shut down after rotor lock is detected. The output shutdown period, t_{OFF}, depends C_{LCK} being discharged from the high threshold to the low threshold at the discharge current I_{LCKDL}, typically 0.7μA.

$$t_{OFF} = \frac{C_{LCK} (V_{CLKTHH} - V_{CLKTHL})}{I_{LCKDL}}$$

As above, the threshold voltages and discharge current are fixed, therefore the time depends only on the value of C_{LCK}:

$$t_{OFF} = C_{LCK} \times 6.29 \times 10^6$$

For the default value of C_{LCK}, 0.47μF, t_{OFF} is as follows:

$$t_{OFF} = 0.47 \times 10^{-6} \times 6.29 \times 10^6 = 0.47 \times 6.29 = 2.96s$$

A note on probing C_{LCK}

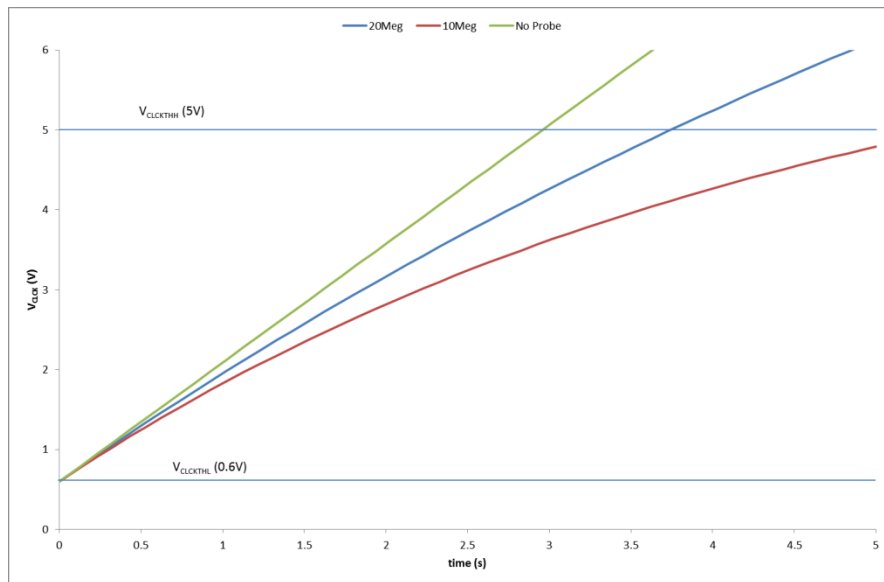

Due to the very small charge and discharge currents involved with C_{LCK}, putting an oscilloscope probe onto that node can have a significant impact on the charge time. The above graph shows simulation for the impact on soft-start t_{SS}. A typical 10X voltage probe will have 10MΩ resistance, which is enough to increase soft-start time from 3 seconds to over 5 seconds. Probing this point can be useful in understanding the operation of the system but it is important to be aware of the impact that the scope probe will have on the operation of the circuit.

Application Information (cont.)

Output Device Driving

In order to drive the output stage efficiently, it is important to minimise shoot-through currents. The ZXBM1021 has a built-in delay (commutation dead-time) to allow time for re-circulating currents to be absorbed however parasitic shoot-through can still occur. This is when the rapid switch-on of the low-side MOSFET causes a low-going pulse through the high-side MOSFET to the gate, causing it to switch on momentarily. Slowing the switch-on of the low-side MOSFET can eliminate this effect.

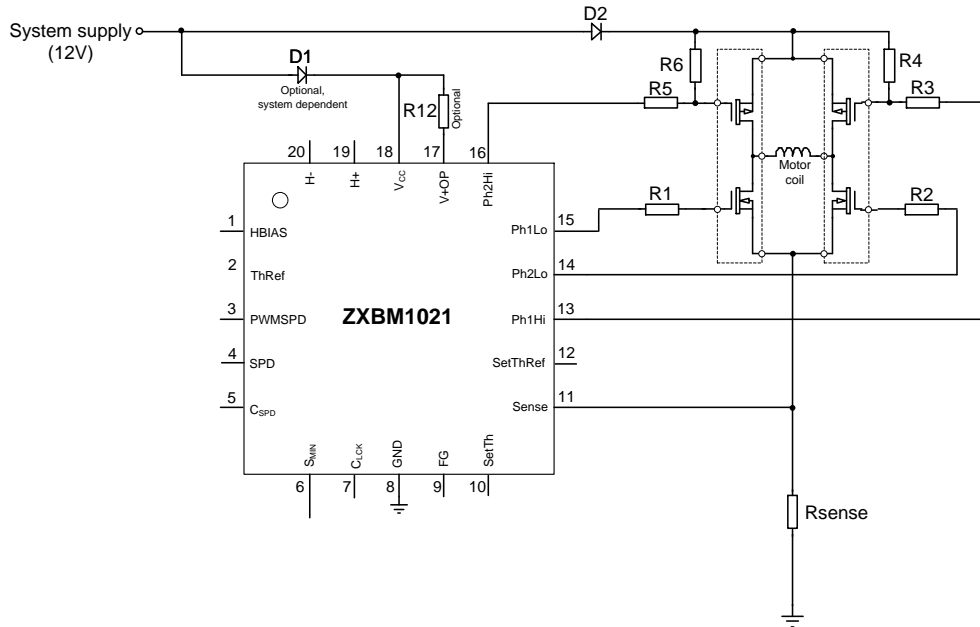

The resistors R1 to R6 and R12 in the diagram allow for control of switch-on and switch-off times for the top and bottom MOSFETs separately.

High-side MOSFETs switching speed:

- R3 and R5 control the discharge of the gates of the high-side P-channel MOSFETs, limiting the switch-on speed.
- R4 and R6 control the charging of the gates of the P-channel MOSFETs, limiting the switch-off speed.

Low-side MOSFETs switching speed:

- R1 and R2 are series gate resistors for the N-channel FETs, affecting both switch-on and switch-off times.
- R12 is the series resistor for the V+OP pin of the ZXBM1021. This resistor is effectively in series with R1 or R2 when that low-side N-channel device is switched on, limiting the switch-on time. R12 allows to vary the switch-on time relative to the switch-off time to prevent parasitic shoot-through at turn-on.

When using bipolar output devices the resistors serve similar functions in limiting the base currents of the transistors.

Application Information (cont.)

External Drive Transistors

Diodes offers a range of devices that are ideally suited to interface between the ZXBM1021 pre-driver and the motor. The following tables show a selection of products. For more comprehensive listings or the latest information please refer to the Diodes website: www.diodes.com.

MOSFETs

Part Number	Type	BV _{DSS} (V)	I _D (A)	R _{DS(ON)} @ V _{GS} = 10V (4.5V for 20V parts) (Ω)	Package
Power Switch: N-Channel MOSFETs					
DMC2020USD	N	20	7.4	0.020	SO8
	P	-20	-5.9	0.033	
DMC2038LVT	N	20	4.5	0.035	TSOT26
	P	-20	-3.2	0.074	
DMC3028LSD	N	30	7.1	0.028	SO8
	P	-30	-7.4	0.025	
DMC4040SSD	N	40	7.5	0.025	SO8
	P	-40	-7.3	0.025	
DMC4028SSD	N	40	7.2	0.028	SO8
	P	-40	-5.2	0.050	
ZXMC4559DN8	N	60	4.7	0.055	SO8
	P	-60	-3.9	0.085	
ZXMC6A09DN8	N	60	5.1	0.045	SO8
	P	-60	-4.8	0.055	

Part Number	Type	BV _{DSS} (V)	I _D (A)	R _{DS(ON)} @ V _{GS} = 10V (Ω)	Package
Power Switch: N-Channel MOSFETs					
ZXMN10A09K	N	100	7.7	0.085	TO252-3L
ZXMN10A25K	N	100	4.0	0.125	TO252-3L
ZXMN10A11G	N	100	2.4	0.35	SOT223
ZXMN10A08DN8	2 x N	100	2.1	0.25	SO8
ZXMN10B08E6	N	100	1.9	0.230	SOT23-6
ZXMN10A07Z	N	100	1.4	0.7	SOT89
ZXMN6A09K	N	60	11.2	0.04	TO252-3L
ZXMN6A25K	N	60	10.7	0.05	TO252-3L
DMN6068LK3	N	60	8.5	0.068	TO252-3L
ZXMN6A09G	N	60	7.5	0.04	SOT223
ZXMN6A25G	N	60	6.7	0.05	SOT223
ZXMN7A11K	N	60	6.1	0.120	TO252-3L
ZXMN6A09DN8	2 x N	60	5.6	0.04	SO8
DMN6068SE	N	60	5.6	0.068	SOT223
ZXMN6A08G	N	60	5.3	0.08	SOT223
ZXMN6A25DN8	2 x N	60	4.7	0.055	SO8
ZXMN6A11Z	N	60	3.6	0.120	SOT89
ZXMN6A07Z	N	60	2.2	0.250	SOT89
ZXMN6A07F	N	60	1.4	0.250	SOT23

Application Information (cont.)

Part Number	Type	B_{VDSS} (V)	I_D (A)	$R_{DS(ON)}$ @ $V_{GS} = 10V$ (Ω)	Package
Power Switch: P-Channel MOSFETS					
ZXMP10A18K	P	-100	-5.9	0.150	TO252
ZXMP10A18G	P	-100	-3.7	0.150	SOT223
ZXMP10A17E6	P	-100	-1.6	0.350	SOT26
ZXPM6A17DN8	2 x P	-60	-3.2	0.125	SO8
ZXMP6A18K	P	-60	-10.4	0.055	TO252
DMP4025LSD	2 x P	-40	-7.6	0.025	SO8
DMP4015SPS	P	-40	-13	0.011	POWERDI5060-8
ZXMP4A16G	P	-40	-6.4	0.060	SOT223
DMP3008SFG	P	-30	-11.7	0.017	POWERDI3333-8

BJTs

Part Number	Type	V_{CEO} (V)	I_C (A)	$V_{CE(sat)}$ @ I_C/I_B (mV @ A/mA)	Package
Power switch: NPN BJT					
FZT855	NPN	150	4	65 @ 0.5/50	SOT223
FMMT624	NPN	125	1	150 @ 0.5/50	SOT23
ZX5T853G	NPN	100	6	125 @ 2/100	SOT223
ZXTN19100CZ	NPN	100	5.25	65 @ 1/100	SOT89
ZXTN25100BFH	NPN	100	3	135 @ 0.5/10	SOT23
ZXTN25100DFH	NPN	100	2.5	170 @ 0.5/10	SOT23
FCX493	NPN	100	1	300 @ 0.5/50	SOT89
FCX1053A	NPN	75	3	200 @ 1/10	SOT89
ZXTN19060CG	NPN	60	7	155 @ 1/10	SOT223
ZX5T851G	NPN	60	6	135 @ 2/50	SOT223
DXT2010P5	NPN	60	5	70 @ 1/10	PowerDI5
FCX493A	NPN	60	1	500 @ 1/50	SOT89
FCX619	NPN	50	3	260 @ 2/50	SOT89
FMMT619	NPN	50	2	220 @ 2/50	SOT23
FCX619	NPN	50	3	260 @ 2/50	SOT89
Drive Buffer and Level Shift					
FMMT493	NPN	100	1	300 @ 0.5/50	SOT89
FMMT493A	NPN	60	1	250 @ 0.5/50	SOT23
ZXTN2038F	NPN	60	1	250 @ 0.5/50	SOT23
DSS41604	NPN	60	1	140 @ 0.5/50	SOT563

Thermal Performance

(1) Package type: QFN4040-20

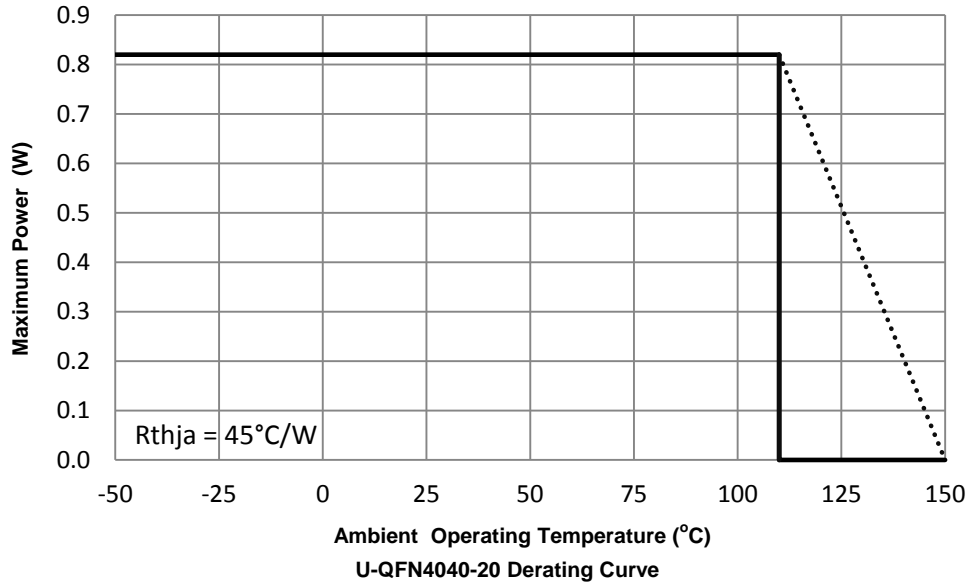

Note: 11. The power dissipation de-rating curve for ZXBM1021 in U-QFN4040-20 package is based on 2"x2" FR4 substrate, 2oz copper, 1.6mm thick PCB with minimum recommended pad layout on the top layer with thermal vias to all copper bottom layer and the 'junction to ambient' thermal resistance (Rthja) of 45°C/W.

(2) Package type: QSOP-20

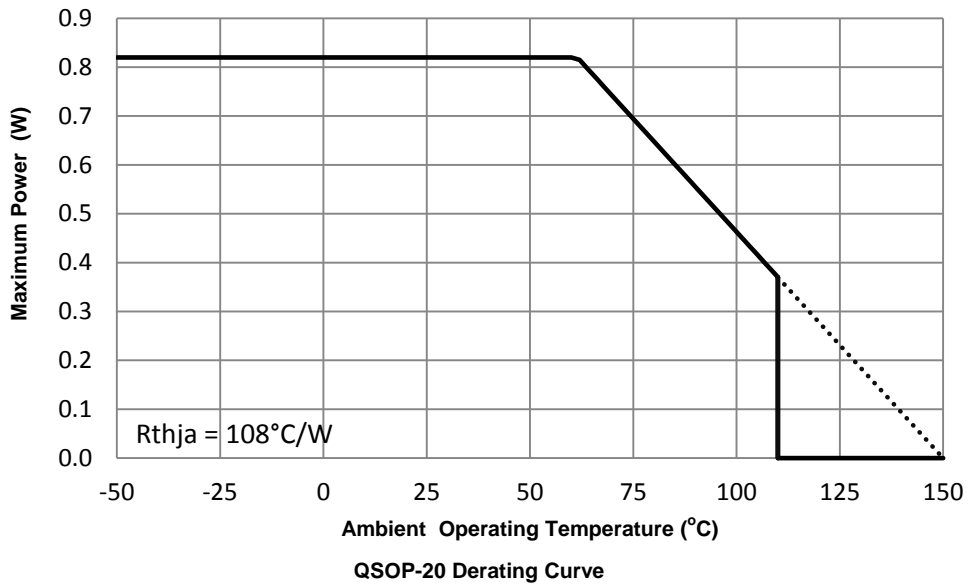

Note: 12. The power dissipation de-rating curve for ZXBM1021 in QSOP-20 package is based on 2"x2" FR4 substrate, 2oz copper, 1.6mm thick PCB all copper top layer (pad layout included) without any vias or the bottom layer copper and the 'junction to ambient' thermal resistance (Rthja) of 108°C/W.

Ordering Information

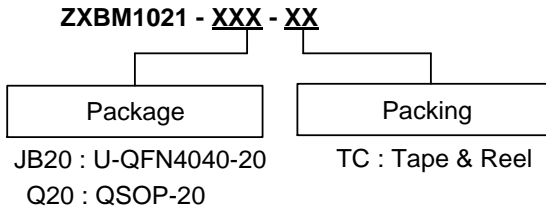

Part Number	Package Code	Packaging	13" Tape and Reel	
			Quantity	Part Number Suffix
ZXBM1021JB20TC	JB20	U-QFN4040-20	3000/Tape & Reel	TC
ZXBM1021Q20TC	Q20	QSOP-20	2500/Tape & Reel	TC

Marking Information

(1) Package type: U-QFN4040-20

(Top View)

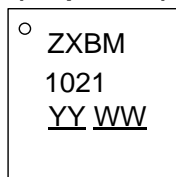

YY : Year : 00 ~ 99;
WW : Week: 01 ~ 52 week;
52 Represents 52 and 53 week

Part Number	Package	Identification Code
ZXBM1021JB20TC	QFN4040-20	ZXBM 1021

(2) Package type: QSOP-20

(Top View)

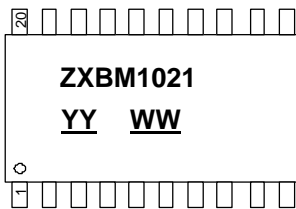

YY : Year: 00 ~ 99;
WW : Week: 01 ~ 52 week;
52 represents 52 and 53 week

Part Number	Package	Identification Code
ZXBM1021Q20TC	QSOP-20	ZXBM1021

Package Outline Dimensions (All dimensions in mm.)

Please see AP02002 at <http://www.diodes.com/datasheets/ap02002.pdf> for latest version.

(1) Package type: U-QFN4040-20

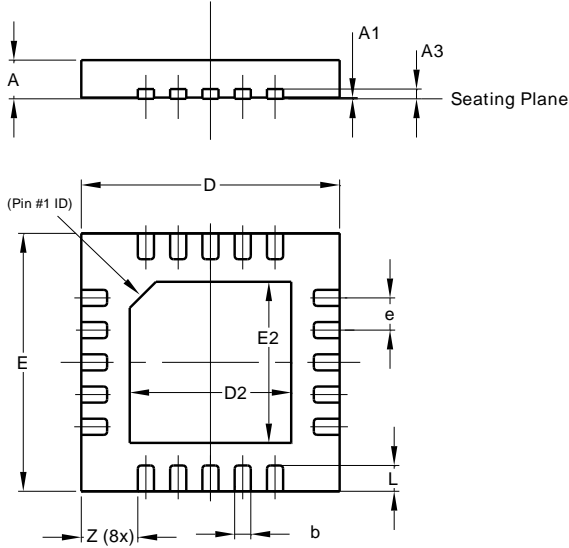

U-QFN4040-20			
Dim	Min	Max	Typ
A	0.55	0.65	0.60
A1	0	0.05	0.02
A3	-	-	0.15
b	0.20	0.30	0.25
D	3.95	4.05	4.00
D2	2.40	2.60	2.50
E	3.95	4.05	4.00
E2	2.40	2.60	2.50
e	0.50 BSC		
L	0.35	0.45	0.40
Z	-	-	0.875
All Dimensions in mm			

(2) Package Type: QSOP-20

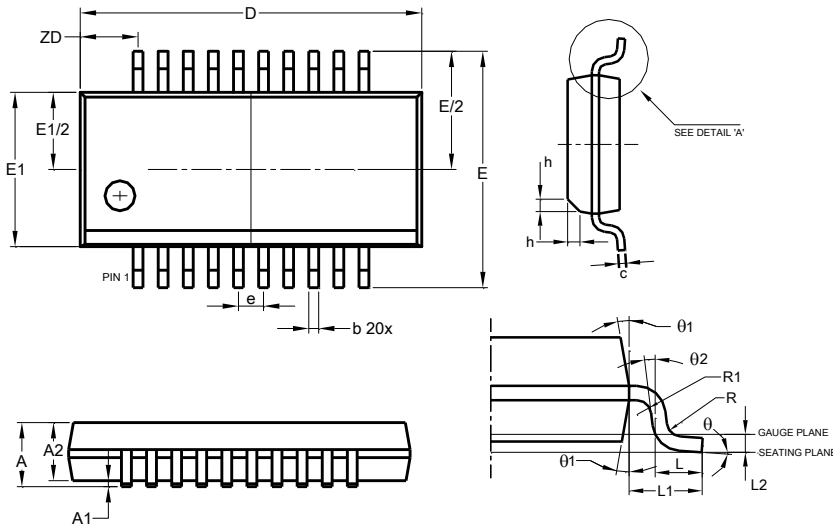

QSOP-20			
Dim	Min	Max	Typ
A	1.55	1.73	-
A1	0.10	0.25	-
A2	1.40	1.50	-
b	0.20	0.30	-
c	0.18	0.25	-
D	8.56	8.74	-
E	5.79	6.20	-
E1	3.81	3.99	-
e	0.635 BSC		
h	0.254	0.508	-
L	0.41	1.27	-
L1	1.03 REF		
L2	0.254 BSC		
R	0.0762	-	-
R1	0.0762	-	-
ZD	1.47 REF		
theta	0°	8°	-
theta1	5°	15°	-
theta2	0°	-	-
All Dimensions in mm			

IMPORTANT NOTICE

DIODES INCORPORATED MAKES NO WARRANTY OF ANY KIND, EXPRESS OR IMPLIED, WITH REGARDS TO THIS DOCUMENT, INCLUDING, BUT NOT LIMITED TO, THE IMPLIED WARRANTIES OF MERCHANTABILITY AND FITNESS FOR A PARTICULAR PURPOSE (AND THEIR EQUIVALENTS UNDER THE LAWS OF ANY JURISDICTION).

Diodes Incorporated and its subsidiaries reserve the right to make modifications, enhancements, improvements, corrections or other changes without further notice to this document and any product described herein. Diodes Incorporated does not assume any liability arising out of the application or use of this document or any product described herein; neither does Diodes Incorporated convey any license under its patent or trademark rights, nor the rights of others. Any Customer or user of this document or products described herein in such applications shall assume all risks of such use and will agree to hold Diodes Incorporated and all the companies whose products are represented on Diodes Incorporated website, harmless against all damages.

Diodes Incorporated does not warrant or accept any liability whatsoever in respect of any products purchased through unauthorized sales channel.

Should Customers purchase or use Diodes Incorporated products for any unintended or unauthorized application, Customers shall indemnify and hold Diodes Incorporated and its representatives harmless against all claims, damages, expenses, and attorney fees arising out of, directly or indirectly, any claim of personal injury or death associated with such unintended or unauthorized application.

Products described herein may be covered by one or more United States, international or foreign patents pending. Product names and markings noted herein may also be covered by one or more United States, international or foreign trademarks.

This document is written in English but may be translated into multiple languages for reference. Only the English version of this document is the final and determinative format released by Diodes Incorporated.

LIFE SUPPORT

Diodes Incorporated products are specifically not authorized for use as critical components in life support devices or systems without the express written approval of the Chief Executive Officer of Diodes Incorporated. As used herein:

A. Life support devices or systems are devices or systems which:

1. are intended to implant into the body, or
2. support or sustain life and whose failure to perform when properly used in accordance with instructions for use provided in the labeling can be reasonably expected to result in significant injury to the user.

B. A critical component is any component in a life support device or system whose failure to perform can be reasonably expected to cause the failure of the life support device or to affect its safety or effectiveness.

Customers represent that they have all necessary expertise in the safety and regulatory ramifications of their life support devices or systems, and acknowledge and agree that they are solely responsible for all legal, regulatory and safety-related requirements concerning their products and any use of Diodes Incorporated products in such safety-critical, life support devices or systems, notwithstanding any devices- or systems-related information or support that may be provided by Diodes Incorporated. Further, Customers must fully indemnify Diodes Incorporated and its representatives against any damages arising out of the use of Diodes Incorporated products in such safety-critical, life support devices or systems.

Copyright © 2014, Diodes Incorporated

www.diodes.com



Компания «ЭлектроПласт» предлагает заключение долгосрочных отношений при поставках импортных электронных компонентов на взаимовыгодных условиях!

Наши преимущества:

- Оперативные поставки широкого спектра электронных компонентов отечественного и импортного производства напрямую от производителей и с крупнейших мировых складов;
- Поставка более 17-ти миллионов наименований электронных компонентов;
- Поставка сложных, дефицитных, либо снятых с производства позиций;
- Оперативные сроки поставки под заказ (от 5 рабочих дней);
- Экспресс доставка в любую точку России;
- Техническая поддержка проекта, помощь в подборе аналогов, поставка прототипов;
- Система менеджмента качества сертифицирована по Международному стандарту ISO 9001;
- Лицензия ФСБ на осуществление работ с использованием сведений, составляющих государственную тайну;
- Поставка специализированных компонентов (Xilinx, Altera, Analog Devices, Intersil, Interpoint, Microsemi, Aeroflex, Peregrine, Syfer, Eurofarad, Texas Instrument, Miteq, Cobham, E2V, MA-COM, Hittite, Mini-Circuits, General Dynamics и др.);

Помимо этого, одним из направлений компании «ЭлектроПласт» является направление «Источники питания». Мы предлагаем Вам помощь Конструкторского отдела:

- Подбор оптимального решения, техническое обоснование при выборе компонента;
- Подбор аналогов;
- Консультации по применению компонента;
- Поставка образцов и прототипов;
- Техническая поддержка проекта;
- Защита от снятия компонента с производства.



Как с нами связаться

Телефон: 8 (812) 309 58 32 (многоканальный)

Факс: 8 (812) 320-02-42

Электронная почта: org@eplast1.ru

Адрес: 198099, г. Санкт-Петербург, ул. Калинина, дом 2, корпус 4, литера А.