

ABSOLUTE MAXIMUM RATINGS

(Note 1)

Supply Voltages

V_{DD} to DGND -0.3V to 5V

V_{EE} to AGND 0.3V to -70V

DGND to AGND (Note 2) $\pm 1V$

Digital Pins

SCL, SDAIN, SDAOUT, INT, AUTO, RESET

SHDN n , AD n DGND - 0.3V to DGND + 5V

Analog Pins

GATE n (Note 3) $V_{EE} - 0.3V$ to $V_{EE} + 12V$

DETECT n Peak Currents (Note 4) $\pm 80mA$

SENSE n $V_{EE} - 0.3V$ to $V_{EE} + 1V$

OUT n $V_{EE} - 70V$ to $V_{EE} + 70V$

OSCIN DGND - 0.3V to DGND + 5V

BYP Current $\pm 1mA$

Operating Ambient Temperature Range

LTC4259AC-1 0°C to 70°C

LTC4259AI-1 -40°C - 85°C

Junction Temperature (Note 5) 150°C

Storage Temperature Range -65°C to 150°C

Lead Temperature (Soldering, 10 sec) 300°C

PACKAGE/ORDER INFORMATION

TOP VIEW		ORDER PART NUMBER
RESET 1	36 OSCIN	LTC4259ACGW-1 LTC4259AIGW-1
BYP 2	35 AUTO	
INT 3	34 OUT1	
SCL 4	33 GATE1	
SDAOUT 5	32 SENSE1	
SDAIN 6	31 OUT2	
AD3 7	30 GATE2	
AD2 8	29 SENSE2	
AD1 9	28 V_{EE}	
AD0 10	27 OUT3	
DETECT1 11	26 GATE3	
DETECT2 12	25 SENSE3	
DETECT3 13	24 OUT4	
DETECT4 14	23 GATE4	
DGND 15	22 SENSE4	
V_{DD} 16	21 AGND	
SHDN1 17	20 SHDN4	
SHDN2 18	19 SHDN3	

GW PACKAGE
36-LEAD PLASTIC SSOP
 $T_{JMAX} = 150^{\circ}C$, $\theta_{JA} = 80^{\circ}C/W$

Order Options Tape and Reel: Add #TR
Lead Free: Add #PBF Lead Free Tape and Reel: Add #TRPBF
Lead Free Part Marking: <http://www.linear.com/leadfree/>

Consult LTC Marketing for parts specified with wider operating temperature ranges.

ELECTRICAL CHARACTERISTICS

The ● denotes the specifications which apply over the full operating temperature range, otherwise specifications are at $T_A = 25^{\circ}C$. AGND = DGND = 0V, $V_{DD} = 3.3V$, $V_{EE} = -48V$ unless otherwise noted (Note 6).

SYMBOL	PARAMETER	CONDITIONS	MIN	TYP	MAX	UNITS	
Power Supplies							
V_{DD}	V_{DD} Supply Voltage		● 3	3.3	4	V	
V_{EE}	V_{EE} Supply Voltage	To Maintain IEEE Compliant Output (Note 7)	● -48		-57	V	
I_{DD}	V_{DD} Supply Current		●	2.5	5	mA	
I_{EE}	V_{EE} Supply Current	Normal Operation Classification Into a Short ($V_{DETECTn} = 0V$) (Note 8)	●	-2	-5	mA	
			●		100	mA	
V_{DDMIN}	V_{DD} UVLO Voltage			2.7		V	
$V_{EEMINON}$	V_{EE} UVLO Voltage (Turning On)	$V_{EE} - AGND$		-31		V	
$V_{EEMINOFF}$	V_{EE} UVLO Voltage (Turning Off)	$V_{EE} - AGND$		-28		V	
Detection							
I_{DET}	Detection Current	First Point, $V_{DETECTn} = -10V$ Second Point, $V_{DETECTn} = -3.5V$	●	235	300	μA	
			●	145	190	μA	
V_{DET}	Detection Voltage Compliance	Open Circuit, Measured at DETECT n Pin	●	-20	-23	V	
R_{DETMIN}	Minimum Valid Signature Resistance		●	15.2	17	19	k Ω
R_{DETMAX}	Maximum Valid Signature Resistance		●	26.7	29	33	k Ω
Classification							
V_{CLASS}	Classification Voltage	0mA < I_{CLASS} < 31mA	●	-16.4	-21	V	
I_{CLASS}	Classification Current Compliance	Into Short ($V_{DETECT} = 0V$)	●	55	75	mA	

ELECTRICAL CHARACTERISTICS

The ● denotes the specifications which apply over the full operating temperature range, otherwise specifications are at $T_A = 25^\circ\text{C}$. $\text{AGND} = \text{DGND} = 0\text{V}$, $V_{\text{DD}} = 3.3\text{V}$, $V_{\text{EE}} = -48\text{V}$ unless otherwise noted (Note 6).

SYMBOL	PARAMETER	CONDITIONS	MIN	TYP	MAX	UNITS	
I_{TCLASS}	Classification Threshold Current	Class 0-1	●	5.5	6.5	7.5	mA
		Class 1-2	●	13	14.5	16	mA
		Class 2-3	●	21	23	25	mA
		Class 3-4	●	31	33	35	mA
		Class 4-Overcurrent	●	45	48	51	mA
Gate Driver							
I_{GON}	GATE Pin Current	Gate On, $V_{\text{GATE}n} = V_{\text{EE}}$	●	-20	-50	-70	μA
I_{GOFF}	GATE Pin Current	Gate Off, $V_{\text{GATE}n} = V_{\text{EE}} + 5\text{V}$	●	30		300	μA
I_{GPD}	GATE Pin Short-Circuit Pull-Down	$V_{\text{GATE}n} = V_{\text{EE}} + 1\text{V}$			50		mA
ΔV_{GATE}	External Gate Voltage ($V_{\text{GATE}n} - V_{\text{EE}}$)	$I_{\text{GATE}n} = -1\mu\text{A}$ (Note 3)	●	10	13	15	V
Output Voltage Sense							
V_{PG}	Power Good Threshold Voltage	$V_{\text{OUT}n} - V_{\text{EE}}$	●	1	2	3	V
I_{VOUT}	Out Pin Bias Current	$0\text{V} > V_{\text{OUT}n} > -10\text{V}$	●			-6	μA
		$-10\text{V} > V_{\text{OUT}n} > -30\text{V}$	●			-18	μA
		$V_{\text{OUT}n} = -48\text{V}$			-20		μA
Current Sense							
V_{CUT}	Overcurrent Detection Sense Voltage	$V_{\text{SENSE}n} - V_{\text{EE}}$, $V_{\text{OUT}n} = V_{\text{EE}}$ (Note 9)		166	187.5	199	mV
V_{LIM}	Current Limit Sense Voltage	$V_{\text{SENSE}n} - V_{\text{EE}}$, $V_{\text{OUT}n} = V_{\text{EE}}$		201	212.5	224	mV
		$V_{\text{SENSE}n} - V_{\text{EE}}$, $V_{\text{OUT}n} = \text{AGND} - 30\text{V}$		201		224	mV
		$V_{\text{SENSE}n} - V_{\text{EE}}$, $V_{\text{OUT}n} = \text{AGND} - 10\text{V}$		30.2			mV
V_{MIN}	DC Disconnect Sense Voltage	$V_{\text{SENSE}n} - V_{\text{EE}}$		2.52	3.75	4.97	mV
V_{SC}	Short-Circuit Sense Voltage				275		mV
I_{SENSE}	SENSE Pin Bias Current	$V_{\text{SENSE}n} = V_{\text{EE}}$			-50		μA
AC Disconnect (Note 10)							
R_{OSCIN}	Input Impedance of OSCIN Pin	$0.1\text{V} < V_{\text{OSCIN}} < 3\text{V}$, $f_{\text{OSCIN}} < 200\text{Hz}$	●	200	500		k Ω
A_{VACD}	Voltage Gain OSCIN to DETECT1, 2	Port Powered, PD Not Present	●	-2.7	-3	-3.3	V/V
		Port Powered, PD Not Present	●	2.7	3	3.3	V/V
I_{ACDMAX}	AC Disconnect DETECT n Output Current	Port Powered, $-6\text{V} < V_{\text{DETECT}n} < 0\text{V}$	●			± 600	μA
I_{ACDMIN}	Remain Connected DETECT Pin Current	Port Powered, $V_{\text{DETECT}n} = -3.4\text{V}$ (C grade)	●	190	230	260	μA
		(I grade)	●	180	230	260	μA
Digital Interface							
V_{OLD}	Digital Output Low Voltage	$I_{\text{SDAOUT}} = 3\text{mA}$, $I_{\text{INT}} = 3\text{mA}$	●			0.4	V
		$I_{\text{SDAOUT}} = 5\text{mA}$, $I_{\text{INT}} = 5\text{mA}$	●			0.7	V
V_{ILD}	Digital Input Low Voltage	SCL, SDA IN , RESET, SHDN n , AUTO, AD n	●			0.8	V
V_{IHD}	Digital Input High Voltage	SCL, SDA IN , RESET, SHDN n , AUTO, AD n	●	2.4			V
R_{PU}	Pull-Up Resistor to V_{DD}	AD n , RESET, SHDN n			50		k Ω
R_{PD}	Pull-Down Resistor to DGND	AUTO			50		k Ω
AC Characteristics							
t_{DETDLY}	Detection Delay	From Detect Command or Application of PD to Port to Detect Complete	●	170		590	ms
t_{DET}	Detection Duration	Time to Measure PD Signature Resistance (Figure 2)	●	170		230	ms
t_{CLSDLY}	Classification Delay	From Successful Detect in Auto or Semiauto Mode to Class Complete	●	10.1		52	ms
		From Classify Command in Manual Mode (Figure 2)	●	10.1		420	ms
t_{CLASS}	Classification Duration	(Figure 2)	●	10.1		13	ms
t_{PON}	Power On Delay, Auto Mode	From Valid Detect to Port On in Auto Mode (Figure 2)	●			130	ms
		From Port On Command to GATE Pin Current = I_{GON} (Note 10)	●			1	ms

ELECTRICAL CHARACTERISTICS

The ● denotes the specifications which apply over the full operating temperature range, otherwise specifications are at $T_A = 25^\circ\text{C}$. AGND = DGND = 0V, $V_{DD} = 3.3\text{V}$, $V_{EE} = -48\text{V}$ unless otherwise noted (Note 6).

SYMBOL	PARAMETER	CONDITIONS	MIN	TYP	MAX	UNITS	
t_{START}	Maximum Current Limit Duration During Port Start-Up	$t_{\text{START}1} = 0, t_{\text{START}0} = 0$ (Figure 3)	●	50	60	70	ms
		$t_{\text{START}1} = 0, t_{\text{START}0} = 1$ (Figure 3)	●	25	30	35	ms
		$t_{\text{START}1} = 1, t_{\text{START}0} = 0$ (Figure 3)	●	100	120	140	ms
		$t_{\text{START}1} = 1, t_{\text{START}0} = 1$ (Figure 3)	●	200	240	280	ms
t_{CUT}	Maximum Current Limit Duration After Port Start-Up	$t_{\text{CUT}1} = 0, t_{\text{CUT}0} = 0$ (Figure 3)	●	50	60	70	ms
		$t_{\text{CUT}1} = 0, t_{\text{CUT}0} = 1$ (Figure 3)	●	25	30	35	ms
		$t_{\text{CUT}1} = 1, t_{\text{CUT}0} = 0$ (Figure 3)	●	100	120	140	ms
		$t_{\text{CUT}1} = 1, t_{\text{CUT}0} = 1$ (Figure 3)	●	200	240	280	ms
DC_{CLMAX}	Maximum Current Limit Duty Cycle	Reg16h = 00h	●	5.8	6.3	6.7	%
t_{DIS}	Disconnect Delay	$t_{\text{DIS}1} = 0, t_{\text{DIS}0} = 0$ (Figures 4, 5)	●	300	360	400	ms
		$t_{\text{DIS}1} = 0, t_{\text{DIS}0} = 1$ (Figures 4, 5)	●	75	90	100	ms
		$t_{\text{DIS}1} = 1, t_{\text{DIS}0} = 0$ (Figures 4, 5)	●	150	180	200	ms
		$t_{\text{DIS}1} = 1, t_{\text{DIS}0} = 1$ (Figures 4, 5)	●	600	720	800	ms
t_{VMIN}	DC Disconnect Minimum Pulse Width Sensitivity	$V_{\text{SENSE}n} - V_{\text{EE}} > 5\text{mV}$, $V_{\text{OUT}n} = -48\text{V}$ (Figure 4) (Note 11)	●		0.02	1	ms

I²C Timing

f_{SCLK}	Clock Frequency	(Note 11)	●		400	kHz
t_1	Bus Free Time	Figure 6 (Notes 11, 12)	●	1.3		μs
t_2	Start Hold Time	Figure 6 (Notes 11, 12)	●	600		ns
t_3	SCL Low Time	Figure 6 (Notes 11, 12)	●	1.3		μs
t_4	SCL High Time	Figure 6 (Notes 11, 12)	●	600		ns
t_5	Data Hold Time	Figure 6 (Notes 11, 12)	●	150		ns
t_6	Data Set-Up Time	Figure 6 (Notes 11, 12)	●	200		ns
t_7	Start Set-Up Time	Figure 6 (Notes 11, 12)	●	600		ns
t_8	Stop Set-Up Time	Figure 6 (Notes 11, 12)	●	600		ns
t_r	SCL, SDAIN Rise Time	Figure 6 (Notes 11, 12)	●	20	300	ns
t_f	SCL, SDAIN Fall Time	Figure 6 (Notes 11, 12)	●	20	150	ns
t_{FLTINT}	Fault Present to INT Pin Low	(Notes 11, 12, 13)	●	20	150	ns
t_{STOPINT}	Stop Condition to INT Pin Low	(Notes 11, 12, 13)	●	60	200	ns
t_{ARAINT}	ARA to INT Pin High Time	(Notes 11, 12)	●	20	300	ns

Note 1: Stresses beyond those listed under Absolute Maximum Ratings may cause permanent damage to the device. Exposure to any Absolute Maximum Rating condition for extended periods may affect device reliability and lifetime.

Note 2: DGND and AGND should be tied together in normal operation.

Note 3: An internal clamp limits the GATE pins to a minimum of 12V above V_{EE} . Driving this pin beyond the clamp may damage the part.

Note 4: When a port powers on or off, the transient voltage on the port couples through C_{DET} (Figure 18). The LTC4259A-1 contains internal protection circuitry to withstand transient currents of up to 80mA for 5ms. As long as the absolute value of the current remains below 80mA, the LTC4259A-1 will keep the voltage at the DETECT $_n$ pin within the absolute maximum voltage range. A properly sized R_{DET} should limit the current to less than 60mA.

Note 5: This IC includes overtemperature protection that is intended to protect the device during momentary overload conditions. Junction temperature will exceed 125°C when overtemperature protection is active. Continuous operation above the specified maximum operating junction temperature may impair device reliability.

Note 6: All currents into device pins are positive; all currents out of device pins are negative. All voltages are referenced to ground (AGND and DGND) unless otherwise specified.

Note 7: The LTC4259A-1 is designed to maintain a port voltage of -46.6V to -57V . The V_{EE} supply voltage range accounts for the drop across the diode, MOSFET and sense resistor.

Note 8: V_{EE} supply current, while classifying a short, is measured indirectly by measuring the DETECT $_n$ pin current while classifying a short.

Note 9: The LTC4259A-1 implements overload current detection per IEEE 802.3af. The minimum overload current (I_{CUT}) is dependent on port voltage; $I_{\text{CUT_MIN}} = 15.4\text{W}/V_{\text{PORT_MIN}}$. An IEEE compliant system using the LTC4259A-1 should maintain port voltage above -46.6V .

Note 10: Unless otherwise specified, AC disconnect specifications require the following conditions: the DETECT pin is connected to the port as shown in Figure 1, a valid sine wave is applied to OSCIN, the OSCFAIL bit is cleared and the AC Disconnect Enable bits are set.

Note 11: Guaranteed by design, not subject to test.

Note 12: Values measured at V_{ILD} and V_{IHD} .

Note 13: If fault occurs during an I²C transaction, the INT pin will not be pulled down until a stop condition is present on the I²C bus.

TYPICAL PERFORMANCE CHARACTERISTICS

Power On Sequence in Auto Mode

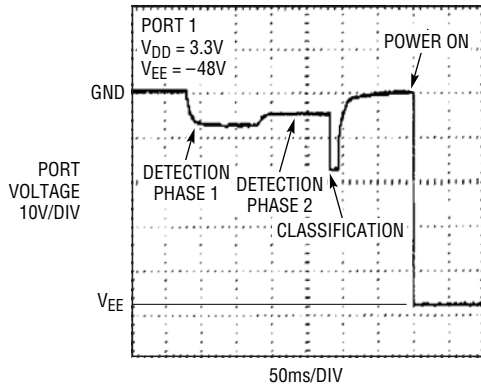

4259 G01

Powering On a 180µF Load

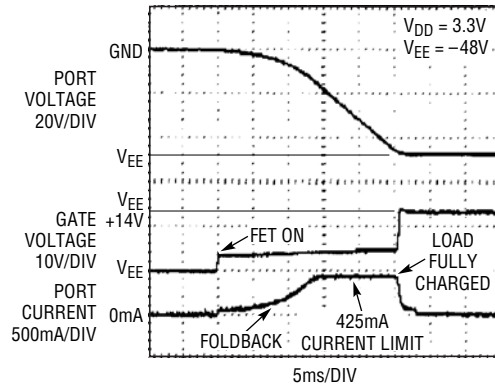

4259 G02

Current Limit Foldback

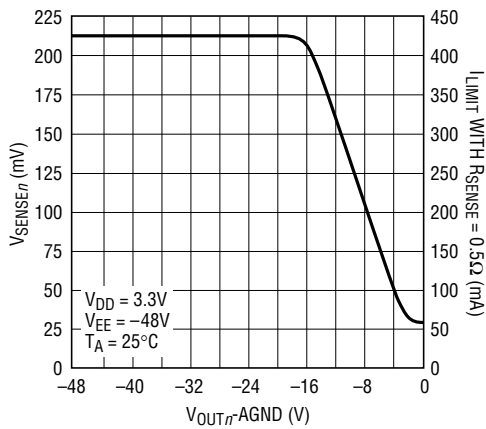

4259 G03

INT and SDAOUT Pull Down Voltage vs Load Current

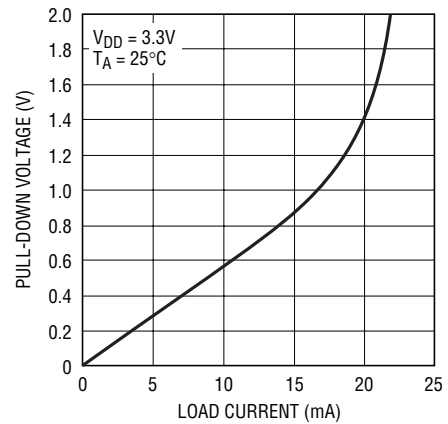

4259 G04

Classification Transient Response to 40mA Load Step

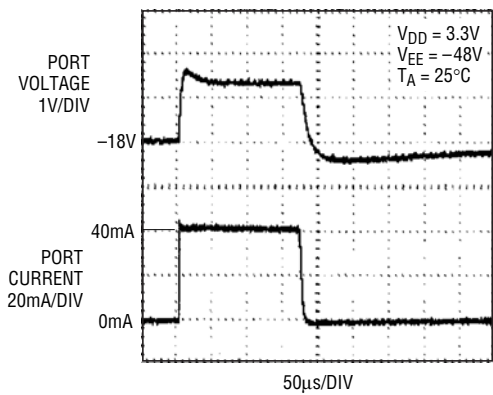

4258 G05

Classification Current Compliance

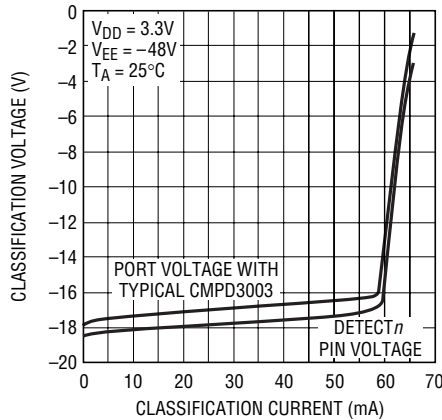

4258 G06

VEE DC Supply Current vs Supply Voltage

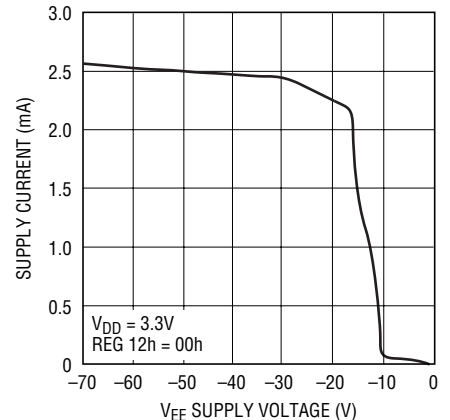

4258 G07

TEST TIMING

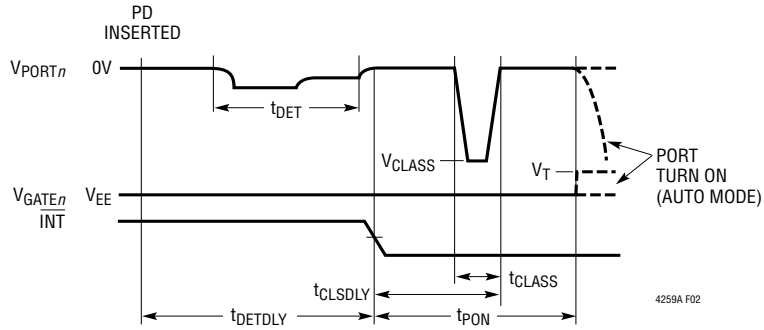

Figure 2. Detect, Class and Turn-On Timing in Auto or Semiauto Modes

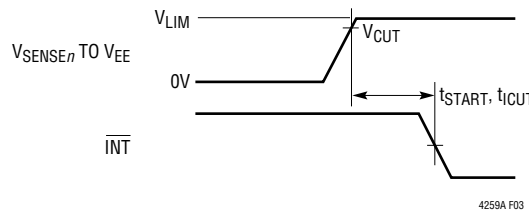

Figure 3. Current Limit Timing

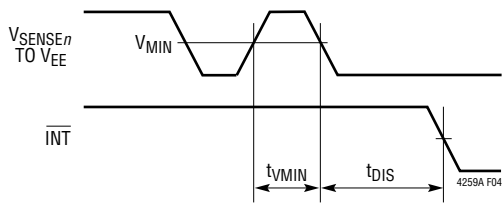

Figure 4. DC Disconnect Timing

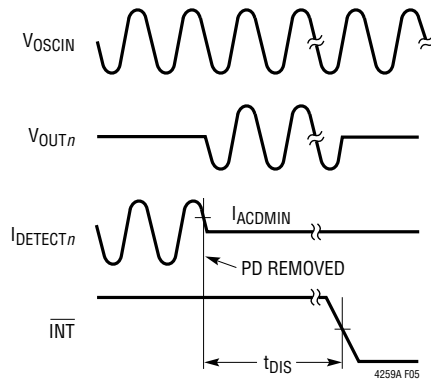

Figure 5. AC Disconnect Timing

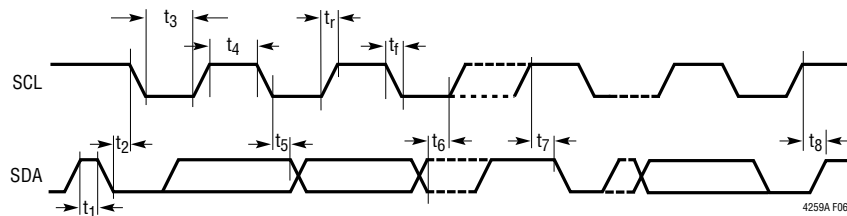

Figure 6. I²C Interface Timing

TIMING DIAGRAMS

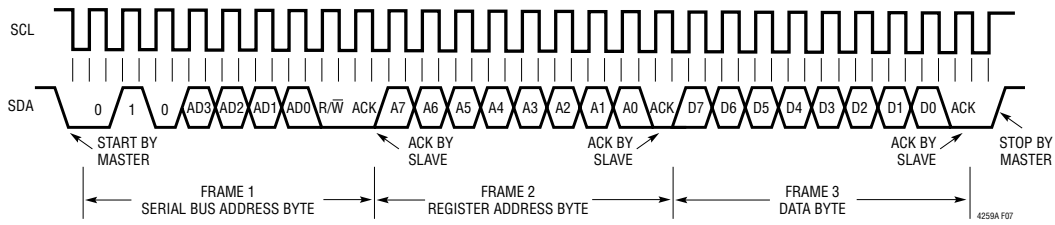

Figure 7. Writing to a Register

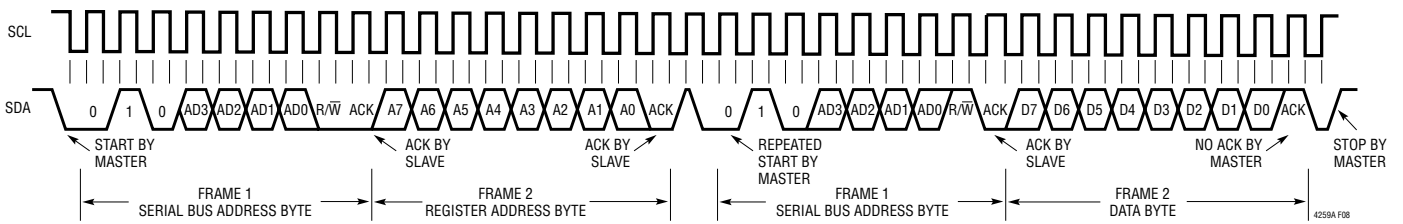

Figure 8. Reading from a Register

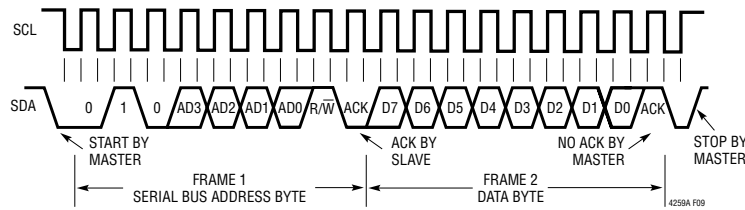

Figure 9. Reading the Interrupt Register (Short Form)

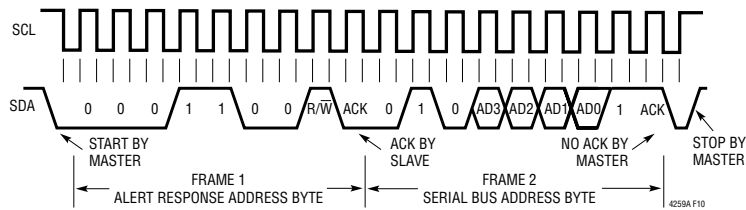

Figure 10. Reading from Alert Response Address

PIN FUNCTIONS

RESET (Pin 1): Chip Reset, Active Low. When the $\overline{\text{RESET}}$ pin is low, the LTC4259A-1 is held inactive with all ports off and all internal registers reset to their power-up states. When $\overline{\text{RESET}}$ is pulled high, the LTC4259A-1 begins normal operation. $\overline{\text{RESET}}$ can be connected to an external capacitor or RC network to provide a power turn-on delay. Internal filtering of the $\overline{\text{RESET}}$ pin prevents glitches less than 1 μs wide from resetting the LTC4259A-1. Pull $\overline{\text{RESET}}$ high with $\leq 10\text{k}$ or tie to V_{DD} .

BYP (Pin 2): Bypass Output. The BYP pin is used to connect the internally generated -20V supply to an external 0.1 μF bypass capacitor. Use a 100V rated 0.1 μF , X7R capacitor. Do not connect the BYP pin to any other external circuitry.

INT (Pin 3): Interrupt Output, Open Drain. $\overline{\text{INT}}$ will pull low when any one of several events occur in the LTC4259A-1. It will return to a high impedance state when bits 6 or 7 are set in the Reset PB register (1Ah). The $\overline{\text{INT}}$ signal can be used to generate an interrupt to the host processor, eliminating the need for continuous software polling. Individual $\overline{\text{INT}}$ events can be disabled using the Int Mask register (01h). See Register Functions and Applications Information for more information. The $\overline{\text{INT}}$ pin is only updated between I²C transactions.

SCL (Pin 4): Serial Clock Input. High impedance clock input for the I²C serial interface bus. The SCL pin should be connected directly to the I²C SCL bus line.

SDAOUT (Pin 5): Serial Data Output, Open Drain Data Output for the I²C Serial Interface Bus. The LTC4259A-1 uses two pins to implement the bidirectional SDA function to simplify optoisolation of the I²C bus. To implement a standard bidirectional SDA pin, tie SDAOUT and SDAIN together. See Applications Information for more information.

SDAIN (Pin 6): Serial Data Input. High impedance data input for the I²C serial interface bus. The LTC4259A-1 uses two pins to implement the bidirectional SDA function to simplify optoisolation of the I²C bus. To implement a standard bidirectional SDA pin, tie SDAOUT and SDAIN together. See Applications Information for more information.

AD3 (Pin 7): Address Bit 3. Tie the address pins high or low to set the I²C serial address to which the LTC4259A-1

responds. This address will be $(010A_3A_2A_1A_0)_b$. Pull AD3 high or low with $\leq 10\text{k}$ or tie to V_{DD} or DGND.

AD2 (Pin 8): Address Bit 2. See AD3.

AD1 (Pin 9): Address Bit 1. See AD3.

AD0 (Pin 10): Address Bit 0. See AD3.

DETECT1 (Pin 11): Detect Sense, Port 1. The LTC4259A-1 Powered Device (PD) detection, classification and AC disconnect hardware monitors port 1 with this pin. Connect DETECT1 to the output port via a 0.47 μF 100V X7R capacitor in series with a 1k resistor, both in parallel with a low leakage diode (see Figure 1). The resistor and capacitor may be eliminated if AC disconnect is not used. If the port is unused, the DETECT1 pin can be tied to DGND or allowed to float.

DETECT2 (Pin 12): Detection Sense, Port 2. See DETECT1.

DETECT3 (Pin 13): Detection Sense, Port 3. See DETECT1.

DETECT4 (Pin 14): Detection Sense, Port 4. See DETECT1.

DGND (Pin 15): Digital Ground. DGND should be connected to the return from the 3.3V supply. DGND and AGND should be tied together.

V_{DD} (Pin 16): Logic Power Supply. Connect to a 3.3V power supply relative to DGND. V_{DD} must be bypassed to DGND near the LTC4259A-1 with at least a 0.1 μF capacitor.

SHDN1 (Pin 17): Shutdown Port 1, Active Low. When pulled low, $\overline{\text{SHDN1}}$ shuts down port 1, regardless of the state of the internal registers. Pulling $\overline{\text{SHDN1}}$ low is equivalent to setting the Reset Port 1 bit in the Reset Pushbutton register (1Ah). Internal filtering of the $\overline{\text{SHDN1}}$ pin prevents glitches less than 1 μs wide from resetting the LTC4259A-1. Pull $\overline{\text{SHDN1}}$ high with $\leq 10\text{k}$ or tie to V_{DD} .

SHDN2 (Pin 18): Shutdown Port 2, Active Low. See $\overline{\text{SHDN1}}$.

SHDN3 (Pin 19): Shutdown Port 3, Active Low. See $\overline{\text{SHDN1}}$.

SHDN4 (Pin 20): Shutdown Port 4, Active Low. See $\overline{\text{SHDN1}}$.

PIN FUNCTIONS

AGND (Pin 21): Analog Ground. AGND should be connected to the return from the -48V supply. AGND and DGND should be tied together.

SENSE4 (Pin 22): Port 4 Current Sense Input. SENSE4 monitors the external MOSFET current via a 0.5Ω sense resistor between SENSE4 and V_{EE} . Whenever the voltage across the sense resistor exceeds the overcurrent detection threshold V_{CUT} , the current limit fault timer counts up. If the voltage across the sense resistor reaches the current limit threshold V_{LIM} (typically $25\text{mV}/50\text{mA}$ higher), the GATE4 pin voltage is lowered to maintain constant current in the external MOSFET. See Applications Information for further details. If the port is unused, the SENSE4 pin must be tied to V_{EE} .

GATE4 (Pin 23): Port 4 Gate Drive. GATE4 should be connected to the gate of the external MOSFET for port 4. When the MOSFET is turned on, a $50\mu\text{A}$ pull-up current source is connected to the pin. The gate voltage is clamped to 13V (typ) above V_{EE} . During a current limit condition, the voltage at GATE4 will be reduced to maintain constant current through the external MOSFET. If the fault timer expires, GATE4 is pulled down with $50\mu\text{A}$, turning the MOSFET off and recording a t_{CUT} or t_{START} event. If the port is unused, float the GATE4 pin or tie it to V_{EE} .

OUT4 (Pin 24): Port 4 Output Voltage Monitor. OUT4 should be connected to the output port through a 10k series resistor. A current limit foldback circuit limits the power dissipation in the external MOSFET by reducing the current limit threshold when the port voltage is within 18V of AGND. The port 4 Power Good bit is set when the voltage from OUT4 to V_{EE} drops below 2V (typ). A $2.5\text{M}\Omega$ resistor is connected internally from OUT4 to AGND. If the port is unused, the OUT4 pin can be tied to AGND or allowed to float.

SENSE3 (Pin 25): Port 3 Current Sense Input. See SENSE4.

GATE3 (Pin 26): Port 3 Gate Drive. See GATE4.

OUT3 (Pin 27): Port 3 Output Voltage Monitor. See OUT4.

V_{EE} (Pin 28): -48V Supply Input. Connect to a -48V to -57V supply, relative to AGND.

SENSE2 (Pin 29): Port 2 Current Sense Input. See SENSE4.

GATE2 (Pin 30): Port 2 Gate Drive. See GATE4.

OUT2 (Pin 31): Port 2 Output Voltage Monitor. See OUT4.

SENSE1 (Pin 32): Port 1 Current Sense Input. See SENSE4.

GATE1 (Pin 33): Port 1 Gate Drive. See GATE 4.

OUT1 (Pin 34): Port 1 Output Voltage Monitor. See OUT4.

AUTO (Pin 35): Auto Mode Input. Auto mode allows the LTC4259A-1 to detect and power up a PD even if there is no host controller present on the I^2C bus. The voltage of the AUTO pin determines the state of the internal registers when the LTC4259A-1 is reset or comes out of V_{DD} UVLO (see the Register map in Table 1). The states of these register bits can subsequently be changed via the I^2C interface. The real-time state of the AUTO pin is read at bit 0 in the Pin Status register (11h). Pull AUTO high or low with $\leq 10\text{k}$ or tie to V_{DD} or DGND.

OSCIN (Pin 36): Oscillator Input. Connect to an oscillating signal source, preferably a sine wave, of approximately 100Hz with 2V peak-to-peak amplitude, negative peaks above -0.3V and positive peaks below 2.5V . When a port is powered and AC disconnect is enabled, this signal is amplified and driven onto the appropriate DETECT pin to determine the AC impedance of the PD.

TABLE 1. REGISTER MAP

ADDRESS REGISTER NAME	R/W	PORT	BIT 7	BIT 6	BIT 5	BIT 4	BIT 3	BIT 2	BIT 1	BIT 0	RESET STATE	RESET STATE
Interrupts												
00h Interrupt	RO	Global	Supply Event Mask 7	t _{START} Fault Mask 6	t _{CURT} Fault Mask 5	Class Complete Mask 4	Detect Complete Mask 3	Disconnect Mask 2	Pwr Good Event Mask 1	Pwr Enable Event Mask 0	Auto Pin Low 1000,0000	Auto Pin High 1000,0000
01h Int Mask	R/W	Global									1000,0000	1110,0100
Events												
02h Power Event	RO	4321	Pwr Good Change 4	Pwr Good Change 3	Pwr Good Change 2	Pwr Good Change 1	Pwr Enable Change 4	Pwr Enable Change 3	Pwr Enable Change 2	Pwr Enable Change 1	0000,0000	0000,0000
03h Power Event CoR	CoR											
04h Detect Event	RO	4321	Class Complete 4	Class Complete 3	Class Complete 2	Class Complete 1	Detect Complete 4	Detect Complete 3	Detect Complete 2	Detect Complete 1	0000,0000	0000,0000
05h Detect Event CoR	CoR											
06h Fault Event	RO	4321	Disconnect 4	Disconnect 3	Disconnect 2	Disconnect 1	t _{CURT} Fault 4	t _{CURT} Fault 3	t _{CURT} Fault 2	t _{CURT} Fault 1	0000,0000	0000,0000
07h Fault Event CoR	CoR											
08h t _{START} Event	RO	4321	Reserved	Reserved	Reserved	Reserved	t _{START} Fault 4	t _{START} Fault 3	t _{START} Fault 2	t _{START} Fault 1	0000,0000	0000,0000
09h t _{START} Event CoR	CoR											
0Ah Supply Event	RO	Global	Over Temp	Reserved	V _{DD} UVLO	V _{EE} UVLO	Reserved	Reserved	Osc Fail	Reserved	0011,0010*	0011,0010*
0Bh Supply Event CoR	CoR											
Status												
0Ch Port 1 Status	RO	1	Reserved	Class Status 2	Class Status 1	Class Status 0	Reserved	Detect Status 2	Detect Status 1	Detect Status 0	0000,0000	0000,0000
0Dh Port 2 Status	RO	2	Reserved	Class Status 2	Class Status 1	Class Status 0	Reserved	Detect Status 2	Detect Status 1	Detect Status 0	0000,0000	0000,0000
0Eh Port 3 Status	RO	3	Reserved	Class Status 2	Class Status 1	Class Status 0	Reserved	Detect Status 2	Detect Status 1	Detect Status 0	0000,0000	0000,0000
0Fh Port 4 Status	RO	4	Reserved	Class Status 2	Class Status 1	Class Status 0	Reserved	Detect Status 2	Detect Status 1	Detect Status 0	0000,0000	0000,0000
10h Power Status	RO	4321	Power Good 4	Power Good 3	Power Good 2	Power Good 1	Power Enable 4	Power Enable 3	Power Enable 2	Power Enable 1	0000,0000	0000,0000
11h Pin Status	RO	Global	Reserved	Reserved	AD3 Pin Status	AD2 Pin Status	AD1 Pin Status	AD0 Pin Status	Reserved	Auto Pin Status	00A ₃ A ₂ A ₁ A ₀ 00	00A ₃ A ₂ A ₁ A ₀ 01
Configuration												
12h Operating Mode	R/W	4321	Port 4 Mode 1	Port 4 Mode 0	Port 3 Mode 1	Port 3 Mode 0	Port 2 Mode 1	Port 2 Mode 0	Port 1 Mode 1	Port 1 Mode 0	0000,0000	1111,1111
13h Disconnect Enable	R/W	4321	AC Discon En 4	AC Discon En 3	AC Discon En 2	AC Discon En 1	DC Discon En 4	DC Discon En 3	DC Discon En 2	DC Discon En 1	0000,0000	1111,0000
14h Detect/Class Enable	R/W	4321	Class Enable 4	Class Enable 3	Class Enable 2	Class Enable 1	Detect Enable 4	Detect Enable 3	Detect Enable 2	Detect Enable 1	0000,0000	1111,1111
15h Reserved	R/W		Reserved	Reserved	Reserved	Reserved	Reserved	Reserved	Reserved	Reserved	0000,0000	0000,0000
16h Timing Config	R/W	Global	Reserved	Reserved	t _{START1}	t _{START0}	t _{CUT1}	t _{CUT0}	t _{DIS1}	t _{DIS0}	0000,0000	0000,0000
17h Misc Config	R/W	Global	Interrupt Pin Enable	Reserved	Osc Fail Mask	Reserved	Reserved	Reserved	Reserved	Reserved	1010,0000	1010,0000
Pushbuttons												
18h Det/Class Restart PB	WO	4321	Restart Class 4	Restart Class 3	Restart Class 2	Restart Class 1	Restart Detect 4	Restart Detect 3	Restart Detect 2	Restart Detect 1	0000,0000	0000,0000
19h Power Enable PB	WO	4321	Power Off 4	Power Off 3	Power Off 2	Power Off 1	Power On 4	Power On 3	Power On 2	Power On 1	0000,0000	0000,0000
1Ah Reset PB	WO	Global	Clear All Interrupts	Clear Interrupt Pin	Reserved	Reset All	Reset Port 4	Reset Port 3	Reset Port 2	Reset Port 1	0000,0000	0000,0000

* The start-up state of the V_{EE} UVLO and Osc Fail bits depend on the order in which the V_{DD} and V_{EE} supplies are brought up. The V_{DD} UVLO bit is not set by the RESET pin or the reset all push button.

Key:

- RO = Read Only
- R/W = Read/Write
- CoR = Clear on Read
- WO = Write Only

CLASS STATUS	DETECT STATUS	MODE BIT ENCODING
000 Class Status Unknown	000 Detect Status Unknown	00 Shutdown
001 Class 1	001 Short Circuit (<1V)	01 Manual
010 Class 2	010 Reserved	10 Semiauto
011 Class 3	011 RLOW	11 Auto
100 Class 4	100 Detect Good	
101 Undefined—Read as Class 0	101 RHIGH	
110 Class 0	110 Open Circuit	
111 Overcurrent	111 Reserved	

REGISTER FUNCTIONS

Interrupt Registers

Interrupt (Address 00h): Interrupt Register, Read Only. A transition to logical 1 of any bit in this register will assert the $\overline{\text{INT}}$ pin (Pin 3) if the corresponding bit in the Int Mask register is set. Each bit is the logical OR of the corresponding bits in the Event registers. The Interrupt register is Read Only and its bits cannot be cleared directly. To clear a bit in the Interrupt register, clear the corresponding bits in the appropriate Status or Event registers or set bit 7 in the Reset Pushbutton register (1Ah).

Int Mask (Address 01h): Interrupt Mask, Read/Write. A logic 1 in any bit of the Int Mask register allows the corresponding Interrupt register bit to assert the $\overline{\text{INT}}$ pin if it is set. A logic 0 in any bit of the Int Mask register prevents the corresponding Interrupt bit from affecting the $\overline{\text{INT}}$ pin. The actual Interrupt register bits are unaffected by the state of the Int Mask register.

Event Registers

Power Event (Address 02h): Power Event Register, Read Only. The lower four bits in this register indicate that the corresponding port Power Enable status bit has changed; the logical OR of these four bits appears in the Interrupt register as the Pwr Enable Event bit. The upper four bits indicate that the corresponding port Power Good status bit has changed; the logical OR of these four bits appears in the Interrupt register as the Pwr Good Event bit. The Power Event bits latch high and will remain high until cleared by reading from address 03h.

Power Event CoR (Address 03h): Power Event Register, Clear on Read. Read this address to clear the Power Event register. Address 03h returns the same data as address 02h and reading address 03h clears all bits at both addresses.

Detect Event (Address 04h): Detect Event Register, Read Only. The lower four bits in this register indicate that at least one detection cycle for the corresponding port has completed; the logical OR of these four bits appears in the Interrupt register as the Detect Complete bit. The upper four bits indicate that at least one classification cycle for the corresponding port has completed; the logical OR of these four bits appears in the Interrupt register as the Class Complete bit. In Manual mode, this register indicates that the requested detection/classification cycle has completed and

the LTC4259A-1 is awaiting further instructions. In Semiauto or Auto modes, these bits indicate that the Detect Status and Class Status bits in the Port Status registers are valid. The Detect Event bits latch high and will remain high until cleared by reading from address 05h.

Detect Event CoR (Address 05h): Detect Event Register, Clear on Read. Read this address to clear the Detect Event register. Address 05h returns the same data as address 04h, and reading address 05h clears all bits at both addresses.

Fault Event (Address 06h): Fault Event Register, Read Only. The lower four bits in this register indicate that a t_{CUT} fault has occurred at the corresponding port; the logical OR of these four bits appears in the Interrupt register as the t_{CUT} Fault bit. The upper four bits indicate that a Disconnect event has occurred at the corresponding port; the logical OR of these four bits appears in the Interrupt register as the Disconnect bit. The Fault Event bits latch high and will remain high until cleared by reading from address 07h.

Fault Event CoR (Address 07h): Fault Event Register, Clear on Read. Read this address to clear the Fault Event register. Address 07h returns the same data as address 06h and reading address 07h clears all bits at both addresses.

t_{START} Event (Address 08h): t_{START} Event Register, Read Only. The lower four bits in this register indicate that a t_{START} fault has occurred at the corresponding port; the logical OR of these four bits appears in the Interrupt register as the t_{START} Fault bit. The t_{START} Event bits latch high and will remain high until cleared by reading from address 09h. The upper four bits in this register are reserved and will always read as 0.

t_{START} Event CoR (Address 09h): t_{START} Event Register, Clear on Read. Read this address to clear the Fault Event register. Address 09h returns the same data as address 08h and reading address 09h clears all bits at both addresses.

Supply Event (Address 0Ah): Supply Event Register, Read Only. Bit 1, Osc Fail, sets when the signal at Pin 36, OSCIN, is absent or does not have the required amplitude and AC disconnect cannot operate properly. The Osc Fail bit latches high and will remain high until cleared by reading at 0Bh. The Osc Fail bit is set after power on or reset unless the V_{EE} supply is not present. Power is removed on ports with AC

REGISTER FUNCTIONS

disconnect enabled independently of the state of the Osc Fail bit. See AC Disconnect under Applications Information for more details. Bit 4 indicates that V_{EE} has dropped below the V_{EE} UVLO level (typically $-28V$). Bit 5 signals that the V_{DD} supply has dropped below the V_{DD} UVLO threshold. Bit 7 indicates that the LTC4259A-1 die temperature has exceeded its thermal shutdown limit (see Note 5 under Electrical Characteristics). The logical OR of bits 1, 4, 5 and 7 appears in the Interrupt register as the Supply Fault bit. See the Misc Config register for information on masking the Osc Fail bit out of the Supply Fault interrupt. The remaining bits in the register are reserved and will always read as 0. The Supply Event bits latch high and will remain high until cleared by reading from address 0Bh.

Supply Event CoR (Address 0Bh): Supply Event Register, Clear on Read. Read this address to clear the Fault Event register. Address 0Bh returns the same data as address 0Ah, and reading address 0Bh clears all bits at both addresses.

Status Registers

Port 1 Status (Address 0Ch): Port 1 Status Register, Read Only. This register reports the most recent detection and classification results for port 1. Bits 0-2 report the status of the most recent detection attempt at the port and bits 4-6 report the status of the most recent classification attempt at the port. If power is on, these bits report the detection/classification status present just before power was turned on. If power is turned off at the port for any reason, all bits in this register will be cleared. See Table 1 for detection and classification status bit encoding.

Port 2 Status (Address 0Dh): Port 2 Status Register, Read Only. See Port 1 Status.

Port 3 Status (Address 0Eh): Port 3 Status Register, Read Only. See Port 1 Status.

Port 4 Status (Address 0Fh): Port 4 Status Register, Read Only. See Port 1 Status.

Power Status (Address 10h): Power Status Register, Read Only. The lower four bits in this register report the switch on/off state for the corresponding ports. The upper four bits (the power good bits) indicate that the drop across the power switch and sense resistor for the corresponding ports is less than 2V (typ) and power start-up is complete. The

power good bits are latched high and are only cleared when a port is turned off or the LTC4259A-1 is reset.

Pin Status (Address 11h): External Pin Status, Read Only. This register reports the real time status of the AUTO (Pin 35) and AD0-AD3 (Pins 7-10) digital input pins. The logic state of the AUTO pin appears at bit 0 and the AD0-AD3 pins at bits 2-5. The remaining bits are reserved and will read as 0. AUTO affects the initial states of some of the LTC4259A-1 configuration registers at start-up but has no effect after start-up and can be used as a general purpose input if desired, as long as it is guaranteed to be in the appropriate state at start-up.

Configuration Registers

Operating Mode (Address 12h): Operating Mode Configuration, Read/Write. This register contains the mode bits for each of the four ports in the LTC4259A-1. See Table 1 for mode bit encoding. At power-up, all bits in this register will be set to the logic state of the AUTO pin (Pin 35). See Operating Modes in the Applications Information section.

Disconnect Enable (Address 13h): Disconnect Enable Register, Read/Write. The lower four bits of this register enable or disable DC disconnect detection circuitry at the corresponding port. If the DC Discon Enable bit is set the port circuitry will turn off power if the current draw at the port falls below I_{MIN} for more than t_{DIS} . I_{MIN} is equal to V_{MIN}/R_S , where R_S is the sense resistor and should be 0.5Ω for IEEE 802.3af compliance. If the bit is clear the port will not remove power due to low current.

The upper four bits enable or disable AC disconnect on the corresponding port. When a port's AC disconnect bit is set, the LTC4259A-1 senses the impedance of that port by forcing an AC voltage on the port's DETECT pin and measuring the AC current. If the DETECT pin sinks less than $I_{ACD_{MIN}}$ for more than t_{DIS} , the port will turn off power. If the bit is clear, the port will not remove power due to high port impedance (AC current below $I_{ACD_{MIN}}$).

The DC and AC disconnect signals that reset t_{DIS} are ORed together and either sensing method (if they are both enabled) will keep the port powered. A port with neither DC or AC disconnect enabled will not power off automatically when the PD is removed.

REGISTER FUNCTIONS

Detect/Class Enable (Address 14h): Detection and Classification Enable, Read/Write. The lower four bits of this register enable the detection circuitry at the corresponding port if that port is in Auto or Semiauto mode. The upper four bits enable the classification circuitry at the corresponding port if that port is in Auto or Semiauto mode. In manual mode, setting a bit in this register will cause the LTC4259A-1 to perform one classification or detection cycle on the corresponding port. Writing to the Detect/Class Restart PB (18h) has the same effect without disturbing the Detect/Class Enable bits for other ports.

Timing Config (Address 16h): Global Timing Configuration, Read/Write. Bits 0-1 program t_{DIS} , the time duration before a port is automatically tuned off after the PD is removed. The LTC4259A-1 can be programmed to monitor whether port current is below I_{MIN} (DC connect) or port impedance is high (AC disconnect). Bits 2-3 program t_{CUT} , the time during which a port's current can exceed I_{CUT} without it being turned off. If the current is still above I_{CUT} after t_{CUT} , the LTC4259A-1 will indicate a t_{CUT} fault and turn the port off. Bits 4-5 program t_{START} , the time duration before an overcurrent condition during port power-on is considered a t_{START} fault and the port is turned off. Note that using the t_{CUT} and t_{START} times other than the default is not compliant with IEEE 802.3af and may double or quadruple the energy dissipated by the external MOSFETs during fault conditions. Bits 6-7 are reserved and should be read/written as 0. See Electrical Characteristics for timer bit encoding. Also see the Applications Information for descriptions of t_{START} , t_{CUT} , DC and AC disconnect timing.

Misc Config (Address 17h): Miscellaneous Configuration, Read/Write. Bit 5 is the Osc Fail Mask; it is set by default. When the Osc Fail Mask bit is clear, it prevents a failure on the OSCIN pin from setting the Osc Fail bit and causing a Supply Event Interrupt. Setting bit 7 enables the \overline{INT} pin. If this bit is reset, the LTC4259A-1 will not pull down the \overline{INT} pin in any condition nor will it respond to the Alert Response Address. This bit is set by default.

Pushbutton Registers

Note Regarding Pushbutton Registers: "Pushbutton" registers are specialized registers that trigger an event when a 1 is written to a bit; writing a 0 to a bit will do nothing. Unlike a standard read/write register, where setting a single bit

involves reading the register to determine its status, setting the appropriate bit in software and writing back the entire register, a pushbutton register allows a single bit to be written without knowing or affecting the status of the other bits in the register. Pushbutton registers are write-only and will return 00h if read.

Det/Class Restart PB (Address 18h): Detection/Classification Restart Pushbutton Register, Write Only. Writing a 1 to any bit in this register will start or restart a single detection or classification cycle at the corresponding port in Manual mode. It can also be used to set the corresponding bits in the Detect/Class Enable register (address 14h) for ports in auto or semiauto mode. The lower 4 bits affect detection on each port while the upper 4 bits affect classification.

Power Enable PB (Address 19h): Power Enable Pushbutton Register, Write Only. The lower four bits of this register set the Power Enable bit in the corresponding Port Status register; the upper four bits clear the corresponding Power Enable bit. Setting or clearing the Power Enable bits via this register will turn on or off the power in any mode except shutdown, regardless of the state of detection or classification. Note that t_{CUT} , t_{START} and disconnect events (if enabled) will still turn off power if they occur.

The Power Enable bit cannot be set if the port has turned off due to a t_{CUT} or t_{START} fault and the t_{CUT} timer has not yet counted back to zero. See Applications Information for more information on t_{CUT} timing.

Clearing the Power Enable bits with this register also clears the detect and fault event bits, the Port Status register, and the Detection and Classification Enable bits for the affected port(s).

Reset PB (Address 1Ah): Reset Pushbutton, Write Only. Bits 0-3 reset the corresponding port by clearing the power enable bit, the detect and fault event bits, the status register and the detection and classification enable bits for that port. Bit 4 returns the entire LTC4259A-1 to the power-on reset state; all ports are turned off, the AUTO pin is reread and all registers are returned to their power-on defaults, except $V_{DD}UVLO$, which remains cleared. Bit 5 is reserved; setting it has no effect. Setting bit 6 releases the Interrupt pin if it is asserted without affecting the Event registers or the Interrupt register. When the \overline{INT} pin is released in this

REGISTER FUNCTIONS

way, the condition causing the LTC4259A-1 to pull the $\overline{\text{INT}}$ pin down must be removed before the LTC4259A-1 will be able to pull $\overline{\text{INT}}$ down again. This can be done by reading and clearing the event registers or by writing a 1 into bit 7

of this register. Setting bit 7 releases the Interrupt pin, clears all the Event registers and clears all the bits in the Interrupt register.

APPLICATIONS INFORMATION

OVERVIEW

Over the years, twisted-pair Ethernet has become the most commonly used method for local area networking. The IEEE 802.3 group, the originator of the Ethernet standard, has defined an extension to the standard, known as 802.3af, which allows DC power to be delivered simultaneously over the same cable used for data communication. This promises a whole new class of Ethernet devices, including IP telephones, wireless access points, and PDA charging stations, which do not require additional AC wiring or external power transformers, a.k.a. “wall warts.” With about 13W of power available, small data devices can be powered by their Ethernet connections, free from AC wall outlets. Sophisticated detection and power monitoring techniques prevent damage to legacy data-only devices, while still supplying power to newer, Ethernet-powered devices over the twisted-pair cable.

A device that supplies power is called Power Sourcing Equipment (PSE); a device that draws power from the wire is called a Powered Device (PD). A PSE is typically an Ethernet switch, router, hub, or other network switching

equipment that is commonly found in the wiring closets where cables converge. PDs can take many forms: digital IP telephones, wireless network access points, PDA or notebook computer docking stations, cell phone chargers, and HVAC thermostats are examples of devices that can draw power from the network.

A PSE is required to provide a nominal 48V DC between either the signal pairs or the spare pairs (but not both) as shown in Figure 11. The power is applied as a voltage between two of the pairs, typically by powering the center-taps of the isolation transformers used to couple the differential data signals to the wire. Since Ethernet data is transformer coupled at both ends and is sent differentially, a voltage difference between the transmit pairs and the receive pairs does not affect the data. A 10base-T/100base-TX Ethernet connection only uses 2 of the 4 pairs in the cable. The unused or spare pairs can be powered directly, as shown in Figure 11, without affecting the data. However, 1000base-T uses all 4 pairs and power must be connected to the transformer center taps if compatibility with 1000base-T is required.

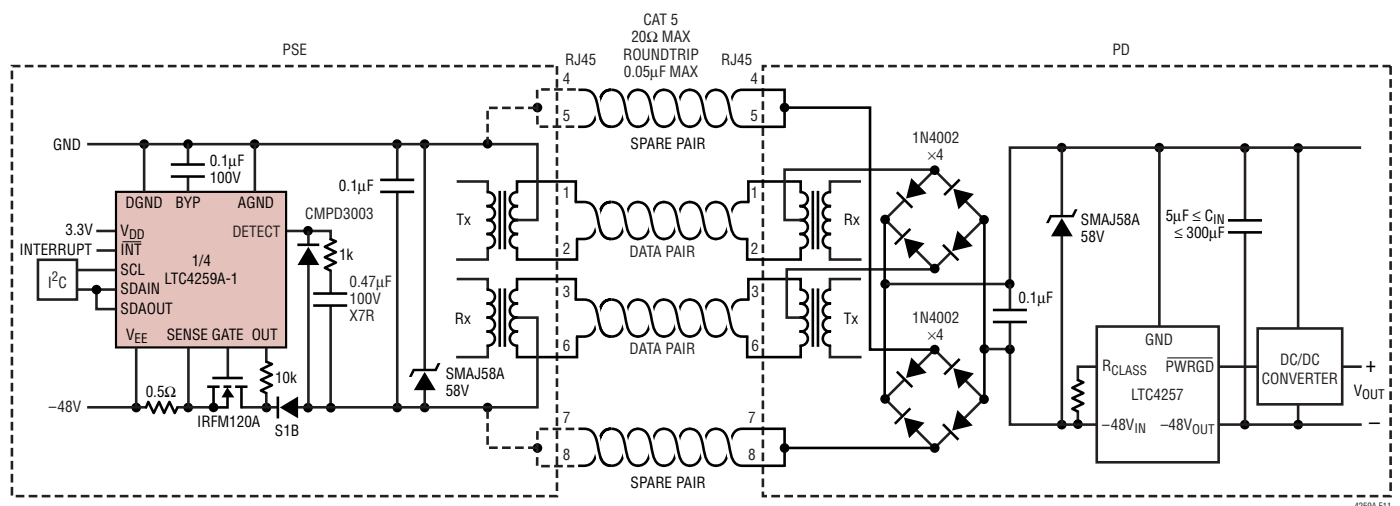

Figure 11. Power over Ethernet System Diagram

4259A1fa

APPLICATIONS INFORMATION

The LTC4259A-1 provides a complete solution for detection and powering of PD devices in an IEEE 802.3af compliant system. The LTC4259A-1 consists of four independent ports, each with the ability to detect, classify, and provide isolated -48V power to a PD device connected to it. The LTC4259A-1 senses removal of a PD with IEEE 802.3af compliant AC or DC methods and turns off -48V power when the PD is removed. An internal control circuit takes care of system configuration and timing, and uses an I²C interface to communicate with the host system.

OPERATING MODES

Each LTC4259A-1 port can operate in one of four modes: Manual, Semiauto, Auto or Shutdown. The operating mode for a port is set by the appropriate bits in the Operating Mode register. The LTC4259A-1 will power up with all ports in Shutdown mode if the external AUTO pin is tied low; if AUTO is high, all ports will wake up in Auto mode. The operating mode can be changed at any time via the I²C interface, regardless of the state of the AUTO pin.

- In Manual mode, a port will wait for instructions from the host system before taking any action. It will run single detection or classification cycles when commanded, and will report results in the Port Status registers. When the host system decides it is time to turn on or off power to a port, it can do so by setting the appropriate Power On/Off bits in the Power Enable PB register regardless of the current status of detection or classification.
- In Semiauto mode, the port will repeatedly attempt to detect and classify a PD device attached to the link. It will report this information in its Port Status register, and wait for the host system to set the appropriate Power On bit in the Power Enable PB register before applying power to the port.
- In Auto mode, the port will detect and classify a PD device connected to it, then immediately turn on the power if detection was successful regardless of the result of classification.
- In Shutdown mode, the port is disabled and will not detect or power a PD. Also, the detect and fault event bits, status bits and enable bits for the port are reset to zero.

Regardless of which mode it is in, the LTC4259A-1 will remove power automatically from any port that generates a t_{START} or t_{ICUT} overcurrent fault event (see t_{ICUT} Timing and t_{START} Timing sections). It will also automatically remove power from any port that generates a disconnect event if the appropriate Disconnect Enable bit is set in the Disconnect Enable register. The host controller may also remove power at any time by setting the appropriate Power Off bit in the Power Enable PB register.

Power-On RESET

At turn-on or any time the LTC4259A-1 is reset (either by pulling the RESET pin low or writing to the global Reset All bit), all the ports turn off and all internal registers go to a predefined state, shown in Table 1.

Several of the registers assume different states based on the state of the AUTO pin at reset. The default states with AUTO high allow the LTC4259A-1 to detect and power up a PD in Automatic mode, even if nothing is connected to the I²C interface.

SIGNATURE DETECTION

The IEEE defines a specific pair-to-pair PD signature resistance that identifies a device that can accept Power over Ethernet in accordance with the 802.3af specification. When the port voltage is below 10V, an 802.3af compliant PD will have a 25k signature resistance. Figure 12 illustrates the relationship between the PD signature resistance (white box from 23.75k to 26.25k) and required resistance ranges the PSE must accept (white box) and reject (gray boxes). According to the 802.3af specification, the PSE may or may not accept resistances in the two ranges of 15k to 19k and 26.5k to 33k. Note that the black box in Figure 12 represents the 150 Ω pair-to-pair termination used in legacy 802.3 devices like a computer's network interface card (NIC) that cannot accept power.

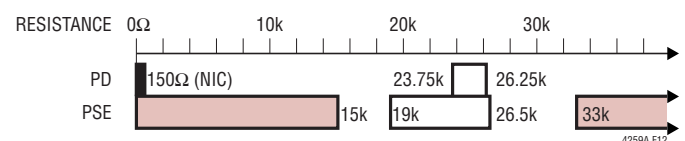

Figure 12. IEEE 802.3af Signature Resistance Ranges

APPLICATIONS INFORMATION

The LTC4259A-1 checks for the signature resistance by forcing two test currents on the port (via the DETECT n pins) in sequence and measuring the resulting voltages. It then subtracts the two V-I points to determine the resistive slope while removing voltage offset caused by any series diodes or current offset caused by leakage at the port (see Figure 13). The LTC4259A-1 will typically accept any PD resistance between 17k and 29k as a valid PD and report Detect Good (100 binary) in the Detect Status bits (bits 2 through 0) of the corresponding Port Status register. Values outside this range, including open and short circuits, are also reported in the Detect Status bits. Refer to Table 1 for a complete decoding of the Detect Status bits.

The first test point is taken by forcing a test current into the port, waiting a short time to allow the line to settle and measuring the resulting voltage. This result is stored and the second current is applied to the port, allowed to settle and the voltage measured. Each point takes about 100ms to measure, and an entire detection cycle takes 230ms (max).

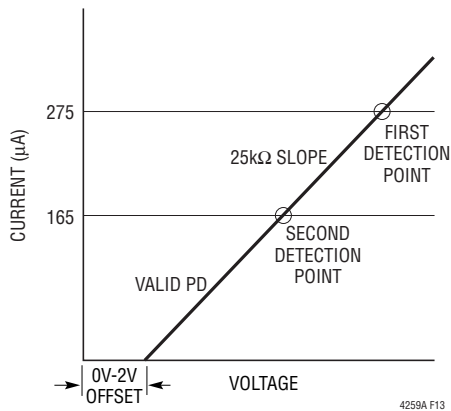

Figure 13. PD Detection

The LTC4259A-1 will not report Detect Good if the PD has more than 5 μ F in parallel with its signature resistor.

The port's operating mode controls if and when the LTC4259A-1 runs a detection cycle. In manual mode, the port will sit idle until a Restart Detection (register 18h) command is received. It will then run a complete 200ms detection cycle on the selected port, report the results in the Detect Status bits in the corresponding Port Status register and return to idle until another command is received. In Semiauto mode, the LTC4259A-1 autonomously tests valid PDs connected to the ports but it will not apply power until instructed to do so by the host controller. It repeatedly queries the port every 320ms and updates the Detect Status bits at the end of each cycle. If a Detect Good is reported, it will advance to the classification phase and report that result in the Port Status register. Until instructed to do otherwise, the LTC4259A-1 will continue to repeat detection on the port. Behavior in Auto mode is similar to Semiauto; however, after a Detect Good is reported, the LTC4259A-1 performs the classification phase and then powers up the port without further intervention.

The signature detection circuitry is disabled when the port is in Shutdown mode, powered up or the corresponding Detect Enable bit is cleared.

CLASSIFICATION

A PD has the option of presenting a “classification signature” to the PSE to indicate how much power it will draw when powered up. This signature consists of a specific constant current draw when the PSE port voltage is between 15.5V and 20.5V, with the current level indicating the power class to which the PD belongs. Per the IEEE 802.3af specification, the LTC4259A-1 identifies the five classes of PD

Table 2. IEEE 802.3af Powered Device Classes

IEEE 802.3af CLASS	CLASSIFICATION CURRENT AT PSE	MAXIMUM PD POWER	MINIMUM PSE OUTPUT POWER	CLASS DESCRIPTION
0	0mA to 5mA	12.95W	15.4W	PD Does Not Implement Classification, Unknown Power
1	8mA to 13mA	3.84W	4W	Low Power PD
2	16mA to 21mA	6.49W	7W	Medium Power PD
3	25mA to 31mA	12.95W	15.4W	High or Full Power PD
4	35mA to 45mA	12.95W	15.4W	Reserved, Power as Class 0

APPLICATIONS INFORMATION

listed in Table 2. During classification, the LTC4259A-1 controls and measures the port voltage through the DETECT n pin. Note that class 4 is presently specified by the IEEE as reserved for future use. Figure 14 shows a PD load line, starting with the shallow slope of the 25k signature resistor below 10V, then drawing the classification current (in this case, class 3) between 14.5V and 20.5V. The LTC4259A-1's load line for classification is also shown in Figure 14. It has low impedance until current limit is reached at 55mA (min).

The LTC4259A-1 will classify a port immediately after a successful detection cycle in Semiauto or Auto modes, or when commanded to in Manual mode. It measures the PD classification signature current by applying 18V (typ) to the port and measuring the resulting current. It reports the detected class in the Class Status bits in the corresponding Port Status register. Note that in Auto mode, the port will power up regardless of which class is detected.

The classification circuitry is disabled when the port is in Shutdown mode, powered up, or the corresponding Class

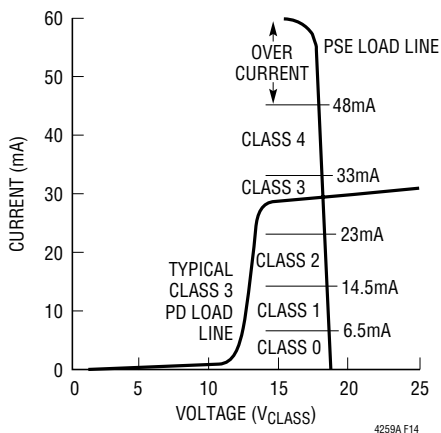

Figure 14. PD Classification

Enable bit is cleared.

POWER CONTROL

The primary function of the LTC4259A-1 is to control the delivery of power to the PSE port. It does this by controlling the gate drive voltage of an external power MOSFET while monitoring the current via a sense resistor and the output voltage at the OUT pin. This circuitry serves to couple the raw isolated -48V input supply to the port in a

controlled manner that satisfies the PD's power needs while minimizing disturbances on the -48V backplane.

Gate Currents

Once the decision has been made to turn on power to a port, the LTC4259A-1 uses a 50 μ A current source to pull up on the GATE pin. Under normal power-up circumstances, the MOSFET gate will charge up rapidly to V_T (the MOSFET threshold voltage), the MOSFET current will rise quickly to the current limit level and the GATE pin will be servoed to maintain the proper I_{INRUSH} charging current. When output charging is complete, the MOSFET current will fall and the GATE pin will be allowed to continue rising to fully enhance the MOSFET and minimize its on resistance. The final V_{GS} is nominally 13V. When a port is turned off, a 50 μ A current source pulls down on the GATE pin, turning the MOSFET off in a controlled manner.

No External Capacitors

No external capacitors are required on the GATE pins for active current limit stability, lowering part count and cost. This also allows the fastest possible turn-off under severe overcurrent conditions, providing maximum safety and protection for the MOSFETs, load devices and board traces. Connecting capacitors to the external MOSFET gates can adversely affect the LTC4259A-1's ability to respond to a shorted port.

Inrush Control

The 802.3af standard lists two separate maximum current limits, I_{LIM} and I_{INRUSH} . Because they have identical values, the LTC4259A-1 implements both as a single current limit using V_{LIM} (described below). Their functions are differentiated through the use of t_{ICUT} and t_{START} , respectively (see t_{ICUT} Timing and t_{START} Timing sections). To maintain consistency with the standard, the I_{INRUSH} term is used when referring to an initial t_{START} power-up event.

When the LTC4259A-1 turns on a port, it turns on the MOSFET by pulling up on the gate. The LTC4259A-1 is designed to power up the port in current limit, limiting the inrush current to I_{INRUSH} .

The port voltage will quickly rise to the point where the PD reaches its input turn-on threshold and begins to draw

APPLICATIONS INFORMATION

current to charge its bypass capacitance, slowing the rate of port voltage increase.

Dual-Level Current Limit

A PD is permitted to draw up to 15.4W continuously and up to 400mA for 50ms. The LTC4259A-1 has two corresponding current limit thresholds, I_{CUT} (375mA typ) and I_{LIM} (425mA typ). These are given by the equations:

$$I_{CUT} = V_{CUT}/R_S, I_{LIM} = V_{LIM}/R_S$$

R_S is the sense resistor and should be 0.5Ω for IEEE 802.3af compliance. While the LTC4259A-1 allows the port current to exceed I_{CUT} for a limited time period (see t_{ICUT} timing below), it does not allow the current to exceed I_{LIM} . The current limit circuit monitors the port current by monitoring the voltage across the sense resistor and reduces the MOSFET gate voltage as needed to keep the current at or below I_{LIM} . When the current drops below I_{LIM} , the gate voltage is restored to the full value to keep the MOSFET resistance to a minimum.

t_{ICUT} Timing

Whenever more than $I_{CUT} = V_{CUT}/R_S$ flows through a port, the port's sense voltage is above V_{CUT} and the t_{ICUT} timer counts up. The t_{ICUT} timer also counts up when the port's OUT pin voltage is above V_{PG} . If either of these conditions persists and the t_{ICUT} timer expires, the LTC4259A-1 will turn off power to the port immediately and set the appropriate t_{ICUT} fault bit in register 06h/07h. The t_{ICUT} duration can be programmed via register 16h, bits 2 and 3 (Table 1).

The t_{ICUT} timer is an up/down counter that is designed to protect the external MOSFET from thermal stress caused by repeatedly operating in current limit. The counter counts up whenever the current is above I_{CUT} and counts down at 1/16th the rate when it is not. The counter will bottom out at zero to prevent underflow. Full count indicates that the t_{ICUT} timer has expired and the port will be turned off.

This count up/count down behavior implements duty cycle protection, preventing intermittent current limit faults from causing cumulative thermal stress in the MOSFET. If the port

enters current limit but then exits before the timer expires, the count will decrease slowly, giving the I_{CUT} timer the ability to turn off sooner in the case of a repetitive fault. If the overcurrent duty cycle is less than 6.3% the t_{ICUT} timer will be fully reset.

If the t_{ICUT} timer expires and causes the port to shut off, the timer will continue to run, counting down at the slow 1/16th rate and preventing the port from being repowered until the count returns to zero. This protects the MOSFET from damage due to a faulty PD that may still have a valid signature, or from errant software that repeatedly writes to the Power On bit.

The port will not repower until after the t_{ICUT} counter returns to zero. In manual and semiauto modes the power enable command must be received after the t_{ICUT} counter reaches zero. In auto mode the LTC4259A-1 must complete a valid detection cycle after the t_{ICUT} counter reaches zero.

t_{START} Timing

To distinguish between normal turn-on current limit behavior and current limit faults which occur after power-up is complete, the LTC4259A-1 starts a timer (the t_{START} timer) whenever a power-up sequence begins.

The t_{START} timer serves three functions. First and foremost, it allows the user to specify a different current limit timeout (t_{START} instead of t_{ICUT}) during turn-on (current limit duty cycle protection remains functional). Second, the DC disconnect timer is disabled during this period and can only begin counting up after the t_{START} timer has expired. Together, these two features let the PD draw the maximum current I_{INRUSH} to charge its input capacitance, boot up and begin drawing power without triggering a t_{START} fault. Finally, if the device is in current limit for the entire t_{START} period, a t_{START} fault will be generated instead of a t_{ICUT} fault. This can be useful for tracking down the cause of an overcurrent fault.

As long as the PD draws less than I_{CUT} at the end of t_{START} and begins drawing the minimum current within t_{DIS} after t_{START} expires (if DC disconnect is enabled), no faults will be indicated.

APPLICATIONS INFORMATION

The t_{START} timer also implements the duty cycle protection described under t_{ICUT} timing and its duration can be programmed via register 16h, bits 5 and 4 (Table 1).

Foldback

Foldback is designed to limit power dissipation in the MOSFET during power-up and momentary short-circuit conditions. At low port output voltages, the voltage across the MOSFET is high, and power dissipation will be large if significant current is flowing. Foldback monitors the port output voltage and reduces the V_{LIM} current limit level linearly from its full value (212.5mV typ) at a port voltage of 18V to approximately 1/7th of the full value (30mV typ) at a port voltage of 0V. With 0.5Ω sense resistors, this limits the short-circuit current to 60mA (typ) instead of the full 425mA (typ) current limit. When the LTC4259A-1 is in foldback, the t_{ICUT} timer is active.

Short-Circuit Protection

If a port is suddenly shorted out, the MOSFET power dissipation can rise to very high levels, jeopardizing the MOSFET even before the normal current limit circuit can respond. A separate short-circuit current limit circuit watches for significant overcurrent events ($V_{SENSE} > 275mV$, $> 550mA$ with a 0.5Ω sense resistor) and pulls the GATE pin down immediately if such an event occurs, shutting off the MOSFET in less than $1\mu s$ (with no external capacitor on GATE). Approximately $100\mu s$ later, GATE is allowed to rise back up and the normal current limit circuit will take over, allowing I_{LIM} current to flow and causing the

t_{ICUT} timer to count up. During a short circuit, I_{LIM} will be reduced by the foldback feature to 1/7th of the nominal value. See Figures 15 and 16 for examples.

Choosing External MOSFETs

Power delivery to the ports is regulated with external power MOSFETs. These MOSFETs are controlled as previously described to meet the IEEE 802.3af specification. Under normal operation, once the port is powered and the PD's bypass capacitor is charged to the port voltage, the external MOSFET dissipates very little power. This suggests that a small MOSFET is adequate for the job. Unfortunately, other requirements of the IEEE 802.3af mandate a MOSFET capable of dissipating significant power. When the port is being powered up, the port voltage must reach 30V or more before the PD turns on. The port voltage can then drop to 0V as the PD's bypass capacitor is charged. According to the IEEE, the PD can directly connect a $180\mu F$ capacitor to the port and the PSE must charge that capacitor with a current limit of 400mA to 450mA for at least 50ms.

An even more extreme example is a noncompliant PD that provides the proper signature during detection but then behaves like a low valued resistor, say 50Ω , in parallel with a $1\mu F$ capacitor. When the PSE has charged this noncompliant PD up to 20V, the 50Ω resistor will draw 400mA (the minimum IEEE prescribed I_{LIM} current limit) keeping the port voltage at 20V for the remainder of t_{START} . The external MOSFET sees 24V to 37V V_{DS} at 400mA to 450mA, dissipating 9.6W to 16.7W for 60ms (typ).

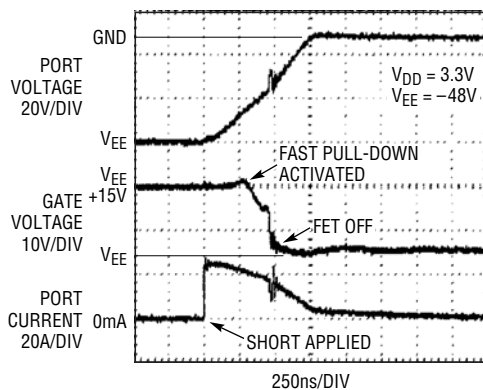

Figure 15. Rapid Response to 1Ω Short

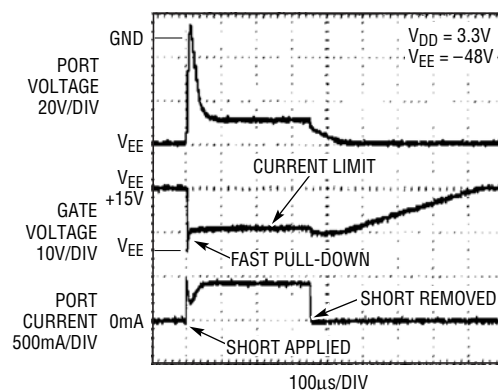

Figure 16. Rapid Response to Momentary 100Ω Short

APPLICATIONS INFORMATION

The LTC4259A-1 implements foldback to reduce the current limit when the MOSFET V_{DS} is high; see the Foldback section. Without foldback, the MOSFET could see as much as 25.7W for 60ms (typ) when powering a shorted or a noncompliant PD with only a few ohms of resistance. With foldback, the MOSFET sees a maximum of 18W for the duration of t_{START} .

The LTC4259A-1's duty cycle protection enforces 15 times longer off time than on time, preventing successive attempts to power a defective PD from damaging the MOSFET. System software can enforce even longer wait times. When the LTC4259A-1 is operated in semiauto or manual mode—described in more detail under Operating Modes—it will not power on a port until commanded to do so by the host controller. By keeping track of t_{START} and t_{CUT} faults, the host controller can delay turning on the port again after one of these faults even if the LTC4259A-1 reports a Detect Good. In this way the host controller implements a MOSFET cooling off period which may be programmed to protect smaller MOSFETs from repeated thermal cycling. The LTC4259A-1 has built-in duty cycle protection for t_{CUT} and t_{START} (see t_{CUT} Timing and t_{START} Timing sections) that is sufficient to protect the MOSFETs shown in Figure 1.

Before designing a MOSFET into your system, carefully compare its safe operating area (SOA) with the worst case conditions (like powering up a defective PD) the device will face. Using transient suppressors, polyfuses and extended wait times after disconnecting a PD are effective strategies to reduce the extremes applied to the external MOSFETs.

Surge Suppressors and Circuit Protection

IEEE 802.3af Power over Ethernet is a challenging Hot Swap application because it must survive the (probably unintentional) abuse of everyone in the building. While hot swapping boards in a networking or telecom card cage is done by a trained technician or network administrator, anyone in the building can plug a device into the network. Moreover, in a card cage the physical domain being powered is confined to the card cage. With Power over Ethernet, the PSE supplies power to devices up to 100 meters away. Ethernet cables could potentially be cut, shorted together, and so on by all kinds of events from a contrac-

tor cutting into walls to someone carelessly sticking a screwdriver where it doesn't belong. Consequently, the Power over Ethernet power source (PSE) must be designed to handle these events.

The most dramatic of these is shorting a powered port. What the PSE sees depends on how much CAT-5 cable is between it and the short. If the short occurs on the far end of a long cable, the cable inductance will prevent the current in the cable from increasing too quickly and the LTC4259A-1's built-in short-circuit protection will take control of the situation and turn off the port. Some energy is stored in the cable, but the transient suppressor on the port clamps the port voltage when the cable inductance causes the voltage to fly back after the MOSFET is turned off. Because the cable only had 600mA or so going through it, an SMAJ58A or equivalent device can easily control the port voltage during flyback. With no cable connected at all, a powered port shorted at the PSE's RJ-45 connector can reach high current levels before the port is shut down. There is no cable inductance to store energy so once the port is shut down the situation is under control.

A short—hence low inductance—piece of CAT-5 will not limit the rapid increase of current when the port is shorted. Even though the LTC4259A-1 short-circuit shutdown is fast, the cable may have many amps flowing through it before the MOSFET can be turned off. Due to the high current, this short piece of cable flies back with significant energy behind it and must be controlled by the transient suppressor. Choosing a surge suppressor that will not develop more than a few volts of forward voltage while passing more than 10A is important. A positive port voltage may forward bias the detect diode (D_{DETn}), bringing the LTC4259A-1's DETECT n pin positive as well and engaging the DETECT n clamps. This will generally not damage the LTC4259A-1 but extreme cases can cause the LTC4259A-1 to reset. When it resets, the LTC4259A-1 signals an interrupt, alerting the host controller which can then return the LTC4259A-1 to normal operating mode.

A substantial transient surge suppressor can typically protect the LTC4259A-1 and the rest of the PSE from these faults. Placing a polyfuse between the RJ-45 connector and the LTC4259A-1 and its associated circuitry can provide additional protection. To meet safety requirements, place the polyfuse in the ground leg of the PSE's output.

APPLICATIONS INFORMATION

DC DISCONNECT

DC disconnect monitors the sense resistor voltage whenever the power is on to make sure that the PD is drawing the minimum specified current. The disconnect timer counts up whenever port current is below 7.5mA (typ). If the t_{DIS} timer runs out, the corresponding port will be turned off and the disconnect bit in the fault register will be set. If the undercurrent condition goes away before the t_{DIS} timer runs out, the timer will reset. The timer will start counting from the beginning if the undercurrent condition occurs again. The undercurrent circuit includes a glitch filter to filter out noise.

The DC disconnect feature can be disabled by clearing the corresponding DC Discon Enable bits in the Disconnect register (13h). The t_{DIS} timer duration can be programmed by bits 1 and 0 of register 16h.

The LTC4259A-1 implements a variety of current sense and limit thresholds to control current flowing through the port. Figure 17 is a graphical representation of these thresholds and the action the LTC4259A-1 takes when current crosses the thresholds.

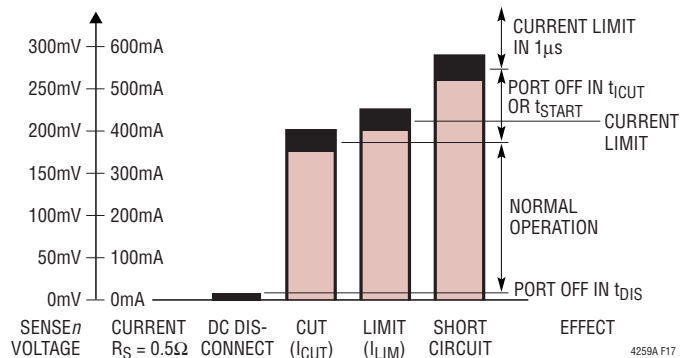

Figure 17. LTC4259A-1 Current Sense and Limits

AC DISCONNECT

AC disconnect is an alternate method of sensing the presence or absence of a PD by monitoring the port impedance. The LTC4259A-1 forces a signal, amplified from the OSCIN pin, out of the DETECT pins and onto the Power over Ethernet connection. It calculates the connection impedance from ohm's law, $Z_{PORT} = V_{AC}/I_{AC}$. Like DC disconnect, the AC disconnect sensing circuitry controls the disconnect timer. When the connection impedance rises (AC current

falls below I_{ACMIN}) due to the removal of the PD, the disconnect timer counts up. If the impedance remains high (AC current remains below I_{ACMIN}), the disconnect timer counts to t_{DIS} , the port is turned off and the port's disconnect bit in the Fault Register is set. If the impedance falls (AC current rises above I_{ACMIN}) before the maximum count of the disconnect timer, the timer resets and the port remains powered.

Like DC disconnect, AC disconnect can also be disabled by clearing the corresponding AC Discon Enable bits in the Disconnect register (13h). AC disconnect is also affected by the t_{DIS} duration programmed in register 16h.

Unlike DC disconnect, AC disconnect has no continuous time output to the timer. Rather, AC disconnect will reset the timer once every cycle, $1/f_{OSCIN}$, of the OSCIN signal if the port draws more than I_{ACMIN} during that period. Because of this behavior, the time to turn off the port after PD removal, t_{DIS} , may vary by up to one cycle of OSCIN ($1/f_{OSCIN}$) from the delay programmed with the t_{DIS1} and t_{DIS0} bits. Note that AC disconnect and DC disconnect signals that reset the t_{DIS} timer are ORed together. Thus on a port where both disconnect modes are enabled, either disconnect sensing method can keep the port powered even if the other reports that there is no PD connected.

The LTC4259A-1 provides a higher AC disconnect threshold, I_{ACMIN} (see Electrical Characteristics) than the LTC4259A. This reduces the port impedance that the LTC4259A-1's AC disconnect circuitry senses as the absence of a PD. Consequently, in the same application circuit the LTC4259A-1 will have less sensitivity to parasitics like leakage and stray capacitance than an LTC4259A. Both the LTC4259A and LTC4259A-1 (used with the recommended application circuit) meet all the AC disconnect requirements of 802.3af standard. Because the LTC4259A-1 offers improved performance, Linear Technology recommends the LTC4259A-1 for new designs and as a replacement for the LTC4259A in existing designs.

The AC disconnect circuitry senses the port and Power over Ethernet connection from the DETECT pins. Connect a $0.47\mu\text{F}$ 100V X7R capacitor (C_{DET}) and a 1k resistor (R_{DET}) from the port's DETECT pin to the port's output as shown in Figure 18. This provides an AC path for sensing

APPLICATIONS INFORMATION

the port impedance. The 1k resistor, R_{DET} , limits current flowing through this path during port power on and power off.

Sizing of capacitors is critical to ensure proper function of AC disconnect. C_{PSE} (Figure 18) controls the connection impedance on the PSE side. Its capacitance must be kept low enough for AC disconnect to be able to sense the PD. For operation near 100Hz, use a C_{PSE} of $0.1\mu F$. On the other hand, C_{DET} has to be large enough to pass the signal at the frequency of $OSCIN$. For $f_{OSCIN} \approx 100Hz$, use at least a $0.47\mu F$ 100V X7R capacitor. The sizes of C_{PSE} , C_{DET} , R_{DET} and the frequency, f_{OSCIN} , are chosen to create an economical, physically compact and functionally robust system. Moreover, the complete Power over Ethernet connection (PSE, transformers, cabling, PD, etc.) is complex; deviating from the recommended values of C_{DET} , R_{DET} and C_{PSE} is discouraged. Contact the LTC Applications department for additional support.

When choosing C_{DET} and C_{PSE} , carefully consider voltage derating of the capacitors. Capacitors built around an X7R dielectric will have about 60% of the specified capacitance

at their rated voltage. Operated at half their rated voltage, X7R capacitors exhibit more than 80% of their specified capacitance. With other ceramic dielectrics commonly used in 50V and 100V chip capacitors, capacitance falls much more dramatically with voltage. At their rated voltage, Y5V or Z5U capacitors exhibit less than 30% of their zero-bias capacitance. Ceramic capacitors can also have significantly less capacitance at elevated temperatures. In order to produce the desired capacitance at the operating bias, 100V or 250V X7R capacitors should be used with the LTC4259A-1.

As illustrated in Figure 19, the Power over Ethernet connection between the PSE and PD includes a large amount of capacitance. Cable capacitance is particularly troubling because CAT-3 and CAT-5 pair-to-pair capacitance is not tightly specified by the IEEE 802.3 standard or well controlled by cable manufacturers. Considering that patch panels, additional connectors, old wiring, etc. are likely to be placed between the PSE and PD, pair-to-pair capacitance is a pretty nebulous quantity. Consequently, the cable's contribution to the port impedance (at the frequency used for AC disconnect) can be a concern.

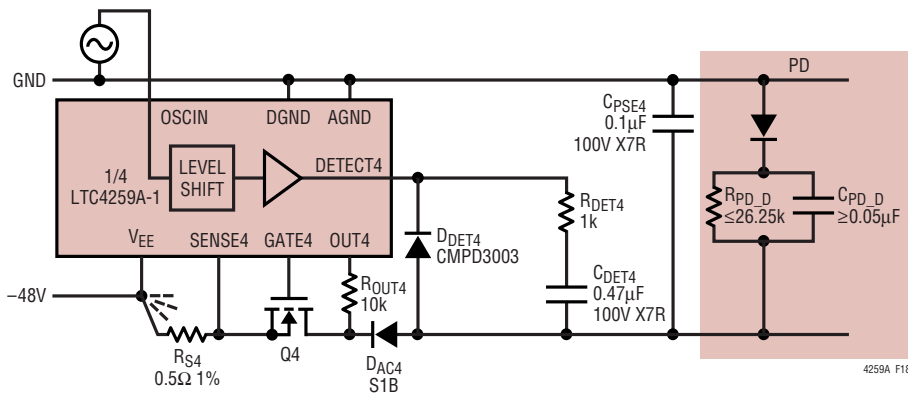

Figure 18. AC Disconnect Single Port Application Circuit (Port 4 Shown)

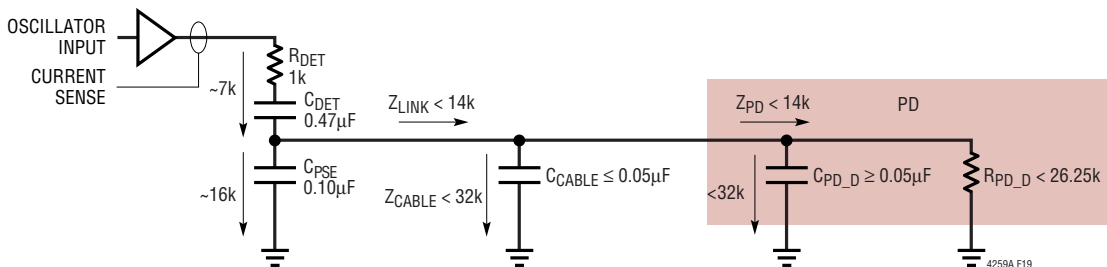

Figure 19. Simplified AC Disconnect Circuit with Impedances at 100Hz

APPLICATIONS INFORMATION

Assuming that f_{OSCIN} is 100Hz, the $0.1\mu\text{F}$ of C_{PSE} plus $0.05\mu\text{F}$ of cable capacitance gives a port impedance of 10k at 100Hz. The PD AC signature resistance is about 25k. Connecting a PD with the maximum allowed resistance of 26.25k brings the connection impedance to about 8k. The presence of a PD only makes a 20% reduction in the port impedance requiring the AC disconnect circuitry to be quite sensitive. When the OSCIN pin is driven with a sine wave, the LTC4259A-1 is able to distinguish between capacitive impedance and resistive impedance on the Power over Ethernet connection. AC disconnect is reliable for cable capacitance up to about $0.2\mu\text{F}$, nearly an order of magnitude greater than worst case for a long CAT-3 or CAT-5 cable.

OSCIN Input and Oscillator Requirements

AC disconnect depends on an external oscillator source applied to the OSCIN pin. The LTC4259A-1 measures port impedance by applying an amplified version of the OSCIN signal to the port's DETECT pin (see Figure 18). The oscillator should be well-controlled because errors in this signal become errors in the measured port impedance. As shown in Figure 19, the load being sensed by AC disconnect has a resistive and a large reactive component. Current through the PD's signature resistor depends on the amplitude of the AC signal while current into the capacitors depends on the slew rate: $I = C \cdot dV/dt$. Consequently, the LTC4259A-1 is sensitive to the amplitude and slew rate of the OSCIN signal, but is more tolerant of frequency and offset errors. Internal limits prevent the LTC4259A-1 from being adversely affected by OSCIN signals with excessive amplitude.

There are many ways to build oscillators with controlled amplitudes and slew rates, especially since the frequency of the oscillator does not have to be well-controlled. Contact the LTC Applications department for oscillator circuits.

As alluded to previously, AC disconnect is complicated and redesigning for different component sizes is a difficult task. For optimum performance, use the recommended component values and drive OSCIN with a 100Hz $2V_{\text{P-P}}$, 1.2V offset sine wave. Keep in mind that the IEEE 802.3af specification places upper limits of 100V/ms on the slew

rate and 500Hz on the frequency of the AC signal at the port. Voltage gain, A_{VACD} , from OSCIN to DETECT n increases the slew rate by the voltage gain. Since A_{VACD} has a maximum absolute value of 3.3V/V ($\pm 3\text{V}$ typ), the slew rate at the OSCIN pin must be less than 30V/ms. A slew rate around 0.6V/ms at OSCIN will work with the recommended values of C_{DET} , R_{DET} and C_{PSE} .

The LTC4259A-1's OSCIN input amplifier will accept signals between DGND $- 0.3\text{V}$ and $V_{\text{DD}} + 0.5\text{V}$. This amplifier has a gain of -1 and is referenced to 1.2V above DGND. An OSCIN voltage greater than 2.2V will cause the amplifier's output to clip against DGND. Clipping will not affect the performance of AC disconnect until the clipping becomes so severe that even the midrange (where the controlled slew rate occurs) of the signal is clipped. Keep the midrange or average voltage of the OSCIN signal between 0.9V and 1.5V to avoid severe clipping. OSCIN signals below DGND can interact with the ESD protection circuitry on the pin and are not recommended. Also, meeting the IEEE 802.3af specification for maximum AC amplitude on the port just after the PD is removed depends on the OSCIN input peak-to-peak amplitude. Clipping by LTC4259A-1's OSCIN input circuitry will generally ensure that this specification is not exceeded. Note that under normal operation, the AC disconnect output on the DETECT n pin will have an amplitude near 6V peak-to-peak. The combination of R_{DET} , C_{DET} and C_{PSE} attenuate the signal so roughly half this amplitude is seen at the port when the port is powered and the PD has just been removed. When the PD is still connected there will be almost no AC signal at the port.

The LTC4259A-1 monitors Pin 36 for the presence of an oscillating signal. If no signal is present and the Osc Fail Mask bit is set, then Osc Fail (bit 1 of the Supply Event register) is set, triggering an interrupt. As the LTC4259A-1's AC disconnect circuitry self-checks the OSCIN signal, the Osc Fail bit is intended as a fault indicator to alert the PSE host controller. The Osc Fail bit has no effect beyond triggering the interrupt. A clear Osc Fail bit indicates that the OSCIN signal goes below 0.6V and above 1.8V at least once every 250ms. It does not necessarily guarantee that AC disconnect will function properly. However, AC disconnect itself is a more thorough test of the OSCIN signal. When the OSCIN signal is either absent or corrupted,

APPLICATIONS INFORMATION

powered ports with AC disconnect enabled (and DC disconnect not enabled) will automatically disconnect. After the LTC4259A-1 is reset (by power on, Reset All bit or the $\overline{\text{RESET}}$ pin) the Osc Fail bit is set. Once the Osc Fail bit is cleared, it will only be set by an invalid signal on the OSCIN pin or another reset.

SERIAL DIGITAL INTERFACE

The LTC4259A-1 communicates with a host (master) using the standard 2-wire interface as described in the SMBus Specification Version 2.0 (available at <http://smbus.org>). The SMBus is an extension of the I²C bus, and the LTC4259A-1 is also compatible with the I²C bus standard. The Timing Diagrams (Figures 6 through 10) show the timing relationship of the signals on the bus. The two bus lines, SDA and SCL, must be high when the bus is not in use. External pull-up resistors or current sources, such as the LTC1694 SMBus accelerator, are required on these lines. If the SDA and SCL pull-ups are absent, not connected to the same positive supply as the LTC4259A-1's V_{DD} pin, or are not activated when the power is applied to the LTC4259A-1, it is possible for the LTC4259A-1 to see a START condition on the I²C bus. The interrupt pin ($\overline{\text{INT}}$) is only updated between I²C transactions. Therefore if the LTC4259A-1 sees a START condition when it powers up because the SCL and SDA lines were left floating, it will not assert an interrupt (pull $\overline{\text{INT}}$ low) until it sees a STOP condition on the bus. In a typical application the I²C bus will immediately have traffic and the LTC4259A-1 will see a STOP so soon after power up that this momentary condition will go unnoticed.

Isolating the Serial Digital Interface

IEEE 802.3af requires that network segments be electrically isolated from the chassis ground of each network interface device. However, the network segments are not required to be isolated from each other provided that the segments are connected to devices residing within a single building on a single power distribution system.

For simple devices such as small powered Ethernet switches, the requirement can be met by using an isolated power supply to power the entire device. This implementation can only be used if the device has no

electrically conducting ports other than twisted-pair Ethernet. In this case, the SDAIN and SDAOUT pins of the LTC4259A-1 can be connected together to act as a standard I²C/SMBus SDA pin.

If the device is part of a larger system, contains serial ports, or must be referenced to protective ground for some other reason, the Power over Ethernet subsystem including the LTC4259A-1s must be electrically isolated from the rest of the system. The LTC4259A-1 includes separate pins (SDAIN and SDAOUT) for the input and output functions of the bidirectional data line. This eases the use of optocouplers to isolate the data path between the LTC4259A-1s and the system controller. Figure 20 shows one possible implementation of an isolated interface. The SDAOUT pin of the LTC4259A-1 is designed to drive the inputs of an optocoupler directly, but a standard I²C device typically cannot. U1 is used to buffer I²C signals into the optocouplers from the system controller side. Schmitt triggers must be used to prevent extra edges on transitions of SDA and SCL.

Bus Addresses and Protocols

The LTC4259A-1 is a read-write slave device. The master can communicate with the LTC4259A-1 using the Write Byte, Read Byte and Receive Byte protocols. The LTC4259A-1's primary serial bus address is (010A₃A₂A₁A₀)_b, as designated by pins AD3-AD0. All LTC4259A-1s also respond to the address (0110000)_b, allowing the host to write the same command into all of the LTC4259A-1s on a bus in a single transaction. If the LTC4259A-1 is asserting (pulling low) the $\overline{\text{INT}}$ pin, it will also acknowledge the Alert Response Address (0001100)_b using the receive byte protocol.

The START and STOP Conditions

When the bus is idle, both SCL and SDA must be high. A bus master (typically the host controller) signals the beginning of communication with a slave device (like the LTC4259A-1) by transmitting a START condition. A START condition is generated by transitioning SDA from high to low while SCL is high. A REPEATED START condition is functionally the same as a START condition, but used to extend the protocol for a change in data transmission

APPLICATIONS INFORMATION

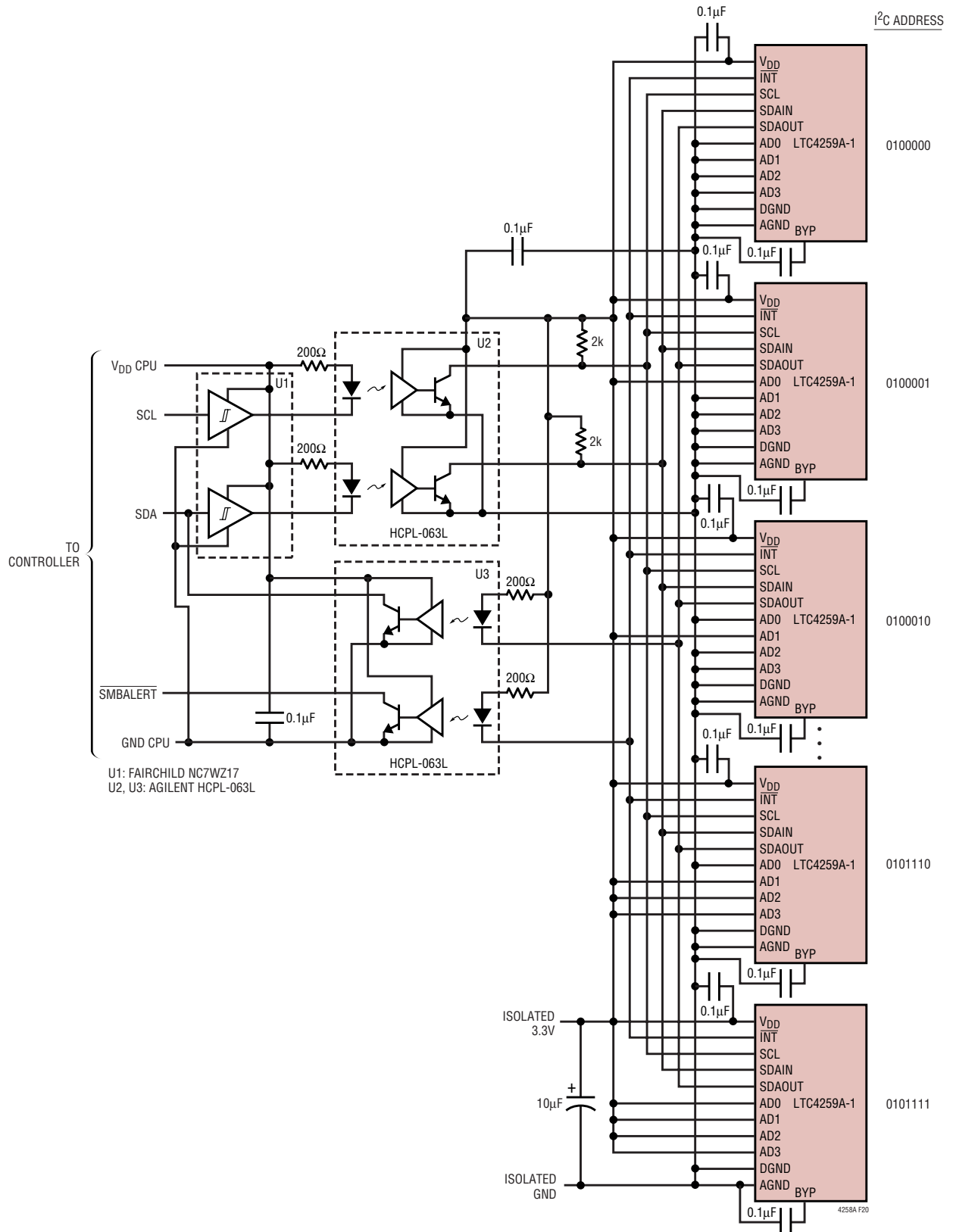

Figure 20. Optoisolating the I²C Bus

APPLICATIONS INFORMATION

direction. A STOP condition is not used to set up a REPEATED START condition, for this would clear any data already latched in. When the master has finished communicating with the slave, it issues a STOP condition. A STOP condition is generated by transitioning SDA from low to high while SCL is high. The bus is then free for communication with another SMBus or I²C device.

Acknowledge

The Acknowledge signal is used for handshaking between the master and the slave. An Acknowledge (active LOW) generated by the slave lets the master know that the latest byte of information was received. The corresponding SCL clock pulse is always generated by the master. The master releases the SDA line (HIGH) during the Acknowledge clock pulse. The slave must pull down the SDA line during the Acknowledge clock pulse so that it remains a stable LOW during the HIGH period of this clock pulse. When the master is reading from a slave device, it is the master's responsibility to acknowledge receipt of the data byte in the bit that follows unless the transaction is complete. In that case the master will decline to acknowledge and issue the STOP condition to terminate the communication.

Write Byte Protocol

The master initiates communication to the LTC4259A-1 with a START condition and a 7-bit bus address followed by the Write Bit (Wr) = 0. If the LTC4259A-1 recognizes its own address, it acknowledges and the master delivers the command byte, signifying to which internal LTC4259A-1 register the master wishes to write. The LTC4259A-1 acknowledges and latches the lower five bits of the command byte into its Register Address register. Only the lower five bits of the command byte are checked by the LTC4259A-1; the upper three bits are ignored. The master then delivers the data byte. The LTC4259A-1 acknowledges once more and latches the data into the appropriate control register. Finally, the master terminates the communication with a STOP condition. Upon reception of the STOP condition, the Register Address register is cleared (see Figure 7).

Read Byte Protocol

The master initiates communication from the LTC4259A-1 with a START condition and the same 7-bit bus address followed by the Write Bit (Wr) = 0. If the LTC4259A-1 recognizes its own address, it acknowledges and the master delivers the command byte, signifying which internal LTC4259A-1 register it wishes to read from. The LTC4259A-1 acknowledges and latches the lower five bits of the command byte into its Register Address register. At this time the master sends a REPEATED START condition and the same 7-bit bus address followed by the Read Bit (Rd) = 1. The LTC4259A-1 acknowledges and sends the contents of the requested register. Finally, the master declines to acknowledge and terminates communication with a STOP condition. Upon reception of the STOP condition, the Register Address register is cleared (see Figure 8).

Receive Byte Protocol

Since the LTC4259A-1 clears the Register Address register on each STOP condition, the interrupt register (register 0) may be read with the Receive Byte Protocol as well as with the Read Byte Protocol. In this protocol, the master initiates communication with the LTC4259A-1 with a START condition and a 7-bit bus address followed by the Read Bit (Rd) = 1. The LTC4259A-1 acknowledges and sends the contents of the interrupt register. The master then declines to acknowledge and terminates communication with a STOP condition (see Figure 9).

Alert Response Address and the $\overline{\text{INT}}$ Pin

In a system where several LTC4259A-1s share a common $\overline{\text{INT}}$ line, the master can use the Alert Response Address (ARA) to determine which LTC4259A-1 initiated the interrupt.

The master initiates the ARA procedure with a START condition and the 7-bit ARA bus address (0001100)b followed by the Read Bit (Rd) = 1. If an LTC4259A-1 is asserting the $\overline{\text{INT}}$ pin, it acknowledges and sends its 7-bit bus address (010A₃A₂A₁A₀)b and a 1 (see Figure 10). While it is sending its address, it monitors the SDA_{IN} pin to see if another device is sending an address at the same

APPLICATIONS INFORMATION

time using standard I²C bus arbitration. If the LTC4259A-1 is sending a 1 and reads a 0 on the SDA_{IN} pin on the rising edge of SCL, it assumes another device with a lower address is sending and the LTC4259A-1 immediately aborts its transfer and waits for the next ARA cycle to try again. If transfer is successfully completed, the LTC4259A-1 will stop pulling down the INT pin. When the INT pin is released in this way or if a 1 is written into the Clear Interrupt pin bit (bit 6 of register 1Ah), the condition causing the LTC4259A-1 to pull the INT pin down must be removed before the LTC4259A-1 will be able to pull INT down again. This can be done by reading and clearing the event registers or by writing a 1 into the Clear All Interrupts bit (bit 7 of register 1Ah). The state of the INT pin can only change between I²C transactions, so an interrupt is cleared or new interrupts are generated after a transaction completes and before new I²C bus communication commences. Periodic polling of the alert response address can be used instead of the INT pin if desired. If any device acknowledges the alert response address, then the INT line, if connected, would have been low.

System Software Strategy

Control of the LTC4259A-1 hinges on one decision, the LTC4259A-1's operating mode. The three choices are described under Operating Modes. In Auto mode the LTC4259A-1 can operate autonomously without direction from a host controller. Because LTC4259A-1s running in Auto mode will power every valid PD connected to them, the PSE must have 15.4W/port available. To reduce the power requirements of the -48V supply, PSE systems can track power usage, only turning on ports when sufficient power is available. The IEEE describes this as a power allocation algorithm and places two limitations: the PSE shall not power a PD unless it can supply the guaranteed power for that PD's class (see Table 2) and power allocation may not be based solely on a history of each PD's power consumption. In order for a PSE to implement power allocation, the PSE's processor/controller must control whether ports are powered—the LTC4259A-1 cannot be allowed to operate in Auto mode. Semiauto mode fits the bill as the LTC4259A-1 automatically detects and classifies PDs, then makes this information available to the host controller, which decides to

apply power or not. Operating the LTC4259A-1 in Manual mode also lets the controller decide whether to power the ports but the controller must also control detection and classification. If the host controller operates near the limit of its computing resources, it may not be able to guide a Manual mode LTC4259A-1 through detect, class and port turn-on in less than the IEEE mandated maximum of 950ms.

In a typical PSE, the LTC4259A-1s will operate in Semiauto mode as this allows the controller to decide to power a port without unduly burdening the controller. With an interrupt mask of F4h, the LTC4259A-1 will signal to the host after it has successfully detected and classed a PD, at which point the host can decide whether enough power is available and command the LTC4259A-1 to turn that port on. Similarly, the LTC4259A-1 will generate interrupts when a port's power is turned off. By reading the LTC4259A-1's interrupt register, the host can determine if a port was turned off due to overcurrent (t_{START} or t_{CUT} faults) or because the PD was removed (Disconnect event). The host then updates the amount of available power to reflect the power no longer consumed by the disconnected PD. Setting the MSB of the interrupt mask causes the LTC4259A-1 to communicate fault conditions caused by failures within the PSE, so the host does not need to poll to check that the LTC4259A-1s are operating properly. This interrupt driven system architecture provides the controller with the final say on powering ports at the same time, minimizing the controller's computation requirements because interrupts are only generated when a PD is detected or on a fault condition.

The LTC4259A-1 can also be used to power older powered Ethernet devices that are not 802.3af compliant and may be detected with other methods. Although the LTC4259A-1 does not implement these older detection methods automatically, if software or external circuitry can detect the noncompliant devices, the host controller may command the LTC4259A-1 to power the port, bypassing IEEE compliant detection and classification and sending power to the noncompliant device.

APPLICATIONS INFORMATION

I_{LIM} , I_{CUT} and I_{MIN} . Therefore, to maintain IEEE compliance, use a resistor with 0.5% or better accuracy.

Power MOSFETs

The LTC4259A-1 controls power MOSFETs in order to regulate current flow through the Ethernet ports. Under certain conditions these MOSFETs have to dissipate significant power. See the Choosing External MOSFETs section for a detailed discussion of the requirements these devices must meet.

Common Mode Chokes

Both nonpowered and powered Ethernet connections achieve best performance (for data transfer, power transfer and EMI) when a common mode choke is used on each port. In the name of cost reduction, some designs share a common mode choke between two adjacent ports. Even for nonpowered Ethernet, sharing a choke is not recommended. With two ports passing through the choke, it cannot limit the common mode current of either port. Instead, the choke only controls the sum of both ports' common mode current. Because cabling from the ports generally connects to different devices up to 200m apart, a current loop can form. In such a loop, common mode current flows in one port and out the other, and the choke will not prevent this because the sum of the currents is zero. Another way to view this interaction between the paired ports is that the choke acts as a transformer coupling the ports' common modes together. In nonpowered Ethernet, common mode current results from nonidealities like ground loops; it is not part of normal operation. However, Power over Ethernet sends power and hence significant current through the ports; common mode current is a byproduct of normal operation. As described in the Choosing External MOSFETs section and under the Power Supplies heading below, large transients can occur when a port's power is turned on or off. When a powered port is shorted (see Surge Suppressors and Circuit Protection), a port's common mode current may be excessive. Sharing a common mode choke between two ports couples start-up, disconnect and fault transients from one port to the other. The end result can range from momentary noncompliance with 802.3af to intermittent behavior and even to excessive

voltages that may damage circuitry (in both the PSE and PD) connected to the ports.

Detect, AC Blocking and Transient Suppressor Diodes

During detection and classification, the LTC4259A-1 senses the port voltage through the detect diodes D_{DET} in Figure 18. Excessive voltage drop across D_{DET} will corrupt the LTC4259A-1's detect and classification results. Select a diode for D_{DET} that will have less than 0.7V of forward drop at 0.4mA and less than 0.9V of forward drop at 50mA.

When the port is powered, the detect diode is reverse biased. Any leakage through the detect diode prevents the LTC4259A-1 from sensing all the current coupled through the C_{DET} capacitor. At high temperature with 70V of reverse bias, a typical switching diode like the 1N4148 may have more than 50 μ A of leakage. Such leakage can interfere with AC disconnect because it is a large fraction of the LTC4259A-1's $I_{ACD_{MIN}}$ threshold. Using a low leakage detect diode like the CMPD3003 is recommended.

The AC blocking diodes can interfere with AC disconnect sensing if they become leaky. If the AC blocking diode (D_{AC} in Figure 18) begins leaking, it contributes to the Ethernet port impedance, potentially bringing the impedance low enough to draw $I_{ACD_{MIN}}$ from the DETECT pin and keep the port powered. More likely, leakage through the AC blocking diode will cause shifts in the AC disconnect threshold that are not large enough to make the PSE noncompliant. Generally, diode leakage is caused by voltage or temperature stress. Diodes that are rated to 100V or more and can handle dissipating at least 0.5W should be acceptable in this application. Other component leakages can have a similar affect on AC disconnect and even affect DC disconnect if the leakage becomes severe. Among components to be wary of are the transient surge suppressors. The devices shown in Figure 1 are rated for less than 5 μ A of leakage at 58V. However there is a potential for stress induced leakage, so healthy margins should be used when selecting diodes for these applications.

Capacitors

Sizing of both the C_{DET} and C_{PSE} capacitors is critical to proper operation of the LTC4259A-1's AC disconnect sensing. See the AC Disconnect section for more information.

APPLICATIONS INFORMATION

Also, C_{PSE} may be important to the voltage stability of a powered port. Port voltage instability is generally not a problem if V_{EE} , the $-48V$ supply, is well bypassed. For both of these reasons be aware that many ceramic dielectrics have dramatic DC voltage and temperature coefficients. A $0.22\mu F$ ceramic capacitor is often nowhere near $0.22\mu F$ when operating at $50VDC$ or $100VDC$. Use $100V$ or higher rated X7R capacitors for C_{DET} and C_{PSE} as these have reduced voltage dependence while also being relatively small and inexpensive.

Power Supplies

The LTC4259A-1 must be supplied with $3.3V$ (V_{DD}) and $-48V$ (V_{EE}). Poor regulation on either of these supplies can lead to noncompliance. The IEEE requires a PSE output voltage between $44V$ and $57V$. When the LTC4259A-1 begins powering an Ethernet port, it controls the current through the port to minimize disturbances on V_{EE} . However, if the V_{EE} supply is underdamped or otherwise unstable, its voltage could go outside of the IEEE specified limits, causing all ports in the PSE to be noncompliant. This scenario can be even worse when a PD is unplugged because the current can drop immediately to zero. In both cases the port voltage must always stay between $-44V$ and $-57V$. In addition, the 802.3af specification places specific ripple, noise and load regulation requirements on the PSE. Among other things, disturbances on either V_{DD} or V_{EE} can adversely affect detection, classification and the AC disconnection sensing. Proper bypassing and stability of the V_{DD} and V_{EE} supplies is important.

Another problem that can affect the V_{EE} supply is insufficient power, leading to the supply voltage drooping out of the specified range. The 802.3af specification states that if a PSE powers a PD it must be able to provide the maximum power level requested by the PD based on the

PD's classification. The specification does allow a PSE to choose not to power a port because the PD requires more power than the PSE has left to deliver. If a PSE is built with a V_{EE} supply capable of less than $15.4W \cdot (\text{number of PSE's Ethernet ports})$, it must implement a power allocation algorithm that prevents ports from being powered when there is insufficient power. Because the specification also requires the PSE to supply $400mA$ at up to a 5% duty cycle, the V_{EE} supply capability should be at least a few percent more than the maximum total power the PSE will supply to PDs. Finally, the LTC4259A-1s draw current from V_{EE} . If the V_{DD} supply is generated from V_{EE} , that power divided by the switcher efficiency must also be added to the V_{EE} supply's capability.

Fast V_{EE} transients can damage the LTC4259A-1. Limit the V_{EE} slew rate to $50mV/\mu s$. In most applications, existing V_{EE} bypass capacitors (described above) will cause the V_{EE} supply to slew much slower than $50mV/\mu s$.

OSCIN Input

AC disconnect also relies on an oscillating signal applied to the OSCIN pin. Requirements for this signal are provided in the OSCIN Input and Oscillator Requirements section. Out-of-band noise on the OSCIN pin will disrupt the LTC4259A-1's ability to sense the absence of a PD. Any noise present at the OSCIN pin is amplified by the LTC4259A-1 and driven out of the DETECT pins (of powered ports with AC disconnect enabled). Due to the amount of capacitance connected to the DETECT pins, driving this noise can easily require more than I_{ACDMIN} , tripping the DETECT pin current sense and keeping the port powered. During circuit board layout, keep wiring from the oscillator to the OSCIN pin away from noise sources like digital clock and data lines. A single-stage RC lowpass filter (shown in Figure 22) will attenuate out-of-band noise.

PACKAGE DESCRIPTION

GW Package
36-Lead Plastic SSOP (Wide .300 Inch)
 (Reference LTC DWG # 05-08-1642)

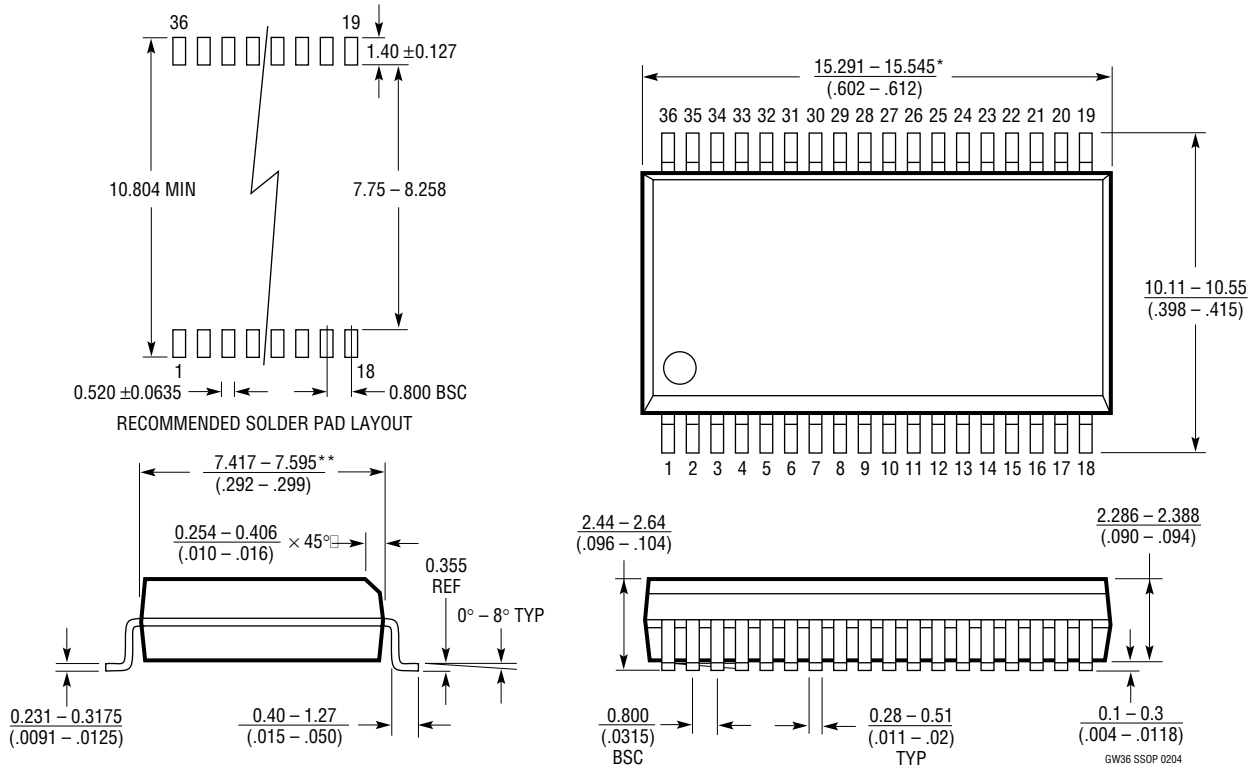

NOTE:

1. CONTROLLING DIMENSION: MILLIMETERS
2. DIMENSIONS ARE IN $\frac{\text{MILLIMETERS}}{\text{(INCHES)}}$

*DIMENSION DOES NOT INCLUDE MOLD FLASH. MOLD FLASH SHALL NOT EXCEED 0.152mm (0.006") PER SIDE

**DIMENSION DOES NOT INCLUDE INTERLEAD FLASH. INTERLEAD FLASH SHALL NOT EXCEED 0.254mm (0.010") PER SIDE

GW36 SSOP 0204

TYPICAL APPLICATION

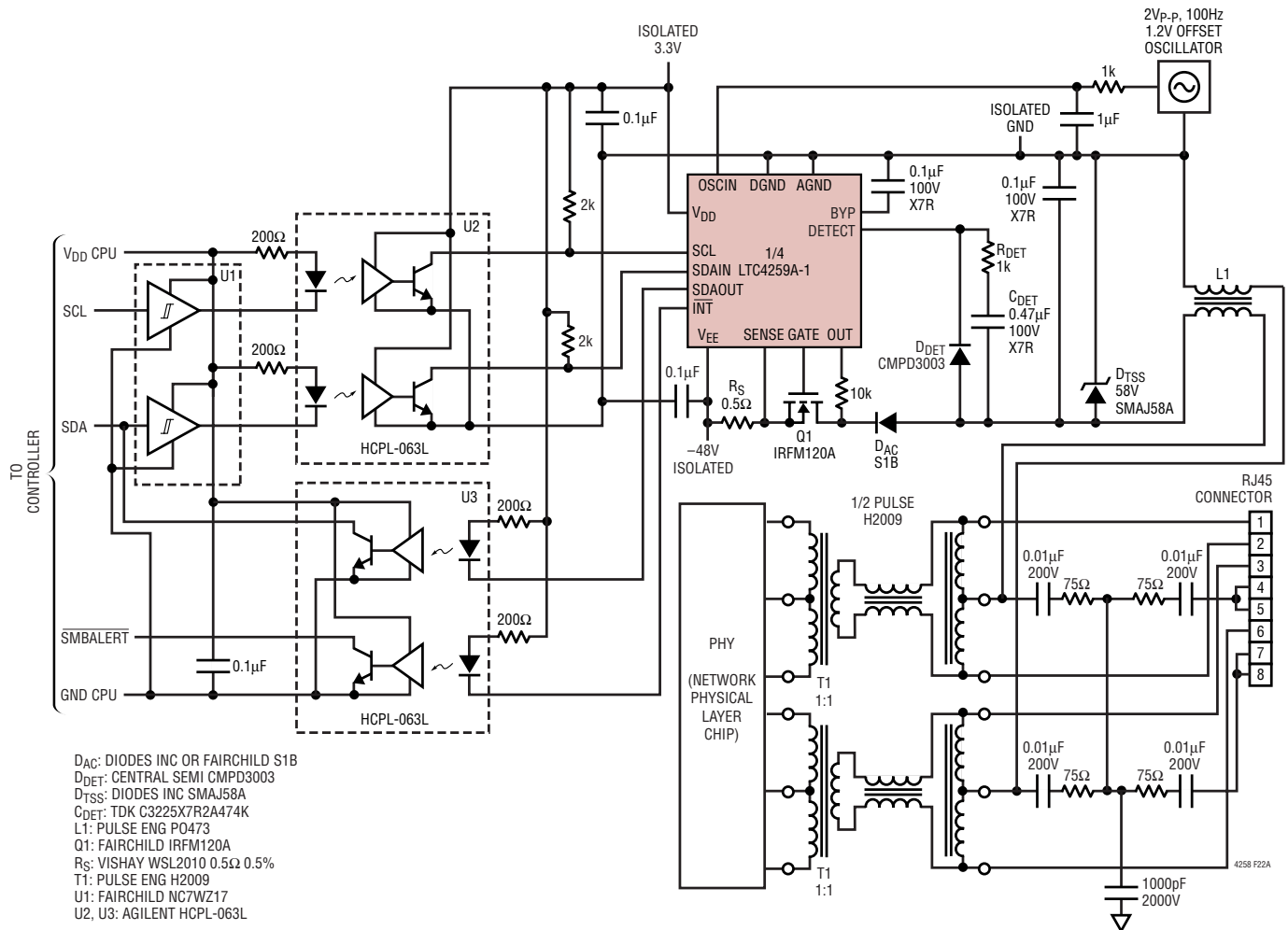

Figure 22. One Complete Isolated Powered Ethernet Port

RELATED PARTS

PART NUMBER	DESCRIPTION	COMMENTS
LT1619	Low Voltage Current Mode PWM Controller	-48V to 3.3V at 300mA, MSOP Package
LTC1694	SMBus/I ² C Accelerator	Improved I ² C Rise Time, Ensures Data Integrity
LTC4255	Quad Network Power Controller	Non-IEEE 802.3af Compliant Current Levels
LTC4257	IEEE 802.3af PD Interface Controller	100V, 400mA Internal Switch, Programmable Class
LTC4257-1	IEEE 802.3af PD Interface Controller	100V, 400mA Internal Switch, Dual Current Limit, Programmable Class
LTC4258	Quad IEEE 802.3af Power Over Ethernet Controller	DC Disconnect Only
LTC4267	IEEE802.3af PD Interface with Integrated Switching Regulator	100V, 400mA UVLO Switch, Dual Inrush Current, Programmable Class



Компания «ЭлектроПласт» предлагает заключение долгосрочных отношений при поставках импортных электронных компонентов на взаимовыгодных условиях!

Наши преимущества:

- Оперативные поставки широкого спектра электронных компонентов отечественного и импортного производства напрямую от производителей и с крупнейших мировых складов;
- Поставка более 17-ти миллионов наименований электронных компонентов;
- Поставка сложных, дефицитных, либо снятых с производства позиций;
- Оперативные сроки поставки под заказ (от 5 рабочих дней);
- Экспресс доставка в любую точку России;
- Техническая поддержка проекта, помощь в подборе аналогов, поставка прототипов;
- Система менеджмента качества сертифицирована по Международному стандарту ISO 9001;
- Лицензия ФСБ на осуществление работ с использованием сведений, составляющих государственную тайну;
- Поставка специализированных компонентов (Xilinx, Altera, Analog Devices, Intersil, Interpoint, Microsemi, Aeroflex, Peregrine, Syfer, Eurofarad, Texas Instrument, Miteq, Cobham, E2V, MA-COM, Hittite, Mini-Circuits, General Dynamics и др.);

Помимо этого, одним из направлений компании «ЭлектроПласт» является направление «Источники питания». Мы предлагаем Вам помощь Конструкторского отдела:

- Подбор оптимального решения, техническое обоснование при выборе компонента;
- Подбор аналогов;
- Консультации по применению компонента;
- Поставка образцов и прототипов;
- Техническая поддержка проекта;
- Защита от снятия компонента с производства.



Как с нами связаться

Телефон: 8 (812) 309 58 32 (многоканальный)

Факс: 8 (812) 320-02-42

Электронная почта: org@eplast1.ru

Адрес: 198099, г. Санкт-Петербург, ул. Калинина, дом 2, корпус 4, литера А.