

### GENERAL DESCRIPTION

The MP2735/MP2736 are low voltage, low on-resistance, dual single-pole, double-throw (SPDT) monolithic CMOS analog switches designed for high performance switching of analog signals. Combining low-power, high speed, low on-resistance, and small package size, the MP2735/MP2736 are ideal for portable and battery power applications.

The MP2735/MP2736 have an operation range from 1.65V to 5.5V single supply. The MP2735 has two separate control pins and two separate SPDT switches. The MP2736 includes an  $\overline{EN}$  pin. All switches are at high impedance mode when the  $\overline{EN}$  is high.

The MP2735/MP2736 are guaranteed 1.65V logic compatible for  $V+ < 3.3V$ , allowing the easy interface with low voltage DSP or MCU control logic and ideal for one cell Li-ion battery direct power.

The switch conducts signals within power rails equally well in both directions when on, and blocks up to the power supply level when off. Break-before-make is guaranteed.

The MP2735/MP2736 are offered in a QFN10 package.

### FEATURES

- Low Voltage Operation (1.65V to 5.5V)
- Low On-Resistance -  $R_{ON}$ : 0.45Ω at 2.7V
- Fast Switching:  $T_{ON}$  = 29ns at 2.7V
- $T_{OFF}$  = 23ns at 2.7V
- Latch-Up Current >300mA (JESD78)
- 1.4mm x 1.8mm QFN10 Package
- ESD Human-Body Model  $\pm 4000V$

### APPLICATIONS

- Cellular Phones
- Speaker Headset Switching
- Audio and Video Signal Routing
- PCMCIA Cards
- Battery Powered Systems
- Portable Media Player
- Handheld Test Instruments

### TRUTH TABLE

	IN1/2	$\overline{EN}$	NC1/2	NO1/2
<b>MP2735</b>	0	-	ON	OFF
	1	-	OFF	ON
<b>MP2736</b>	0	1	OFF	OFF
	1	1	OFF	OFF
	0	0	ON	OFF
	1	0	OFF	ON

"MPS" and "The Future of Analog IC Technology" are Registered Trademarks of Monolithic Power Systems, Inc..

### FUNCTIONAL BLOCK DIAGRAM PIN CONFIGURATION

**MP2735DQG**

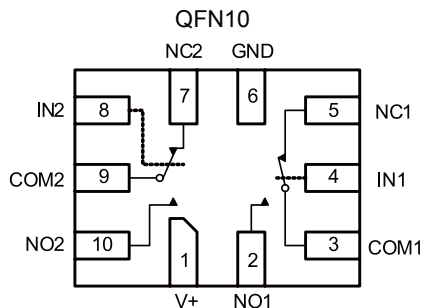

**MP2736DQG**

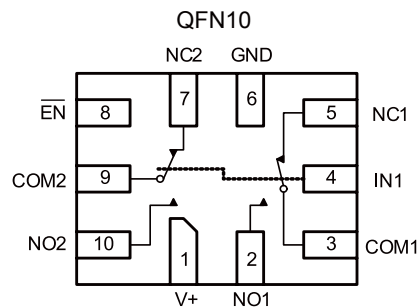

### ORDERING INFORMATION

Part Number*	Package	Top Marking	Free Air Temperature (T <sub>A</sub> )
MP2735DQG	QFN10 (1.4mm x1.8mm)	$\overline{2T}$	-40°C to +85°C
MP2736DQG		$\overline{AM}$	

\* For Tape & Reel, add suffix -Z (e.g. MP2735DQG-Z).  
 For RoHS compliant packaging, add suffix -LF (e.g. MP2735DQG-LF-Z)

### PACKAGE REFERENCE

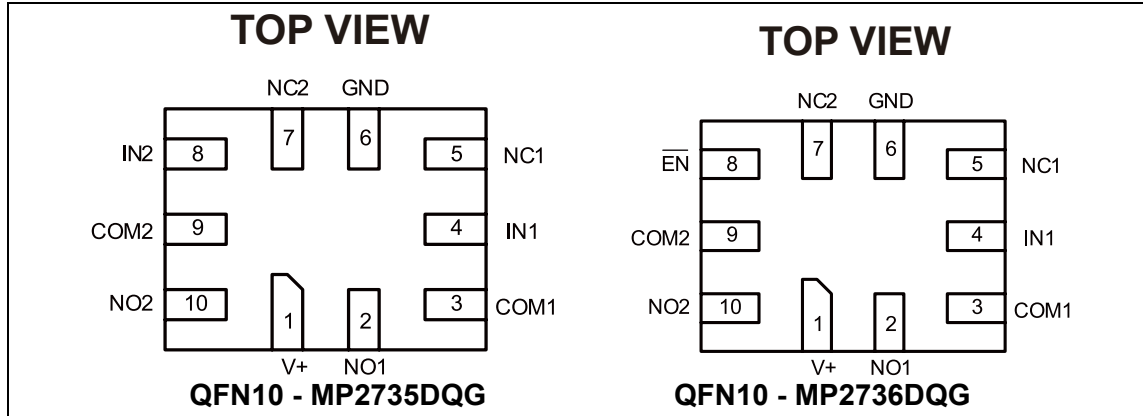

### ABSOLUTE MAXIMUM RATINGS

V+ Supply Voltage .....-0.3V to +6V  
 IN/COM/NC/NO Voltage <sup>(1)</sup> ... -0.3V to V+ + 0.3V  
 Current  
 (Any terminal except NO, NC or COM) .....  
 ..... 30mA  
 Continuous Current (NO, NC or COM) .....  
 ..... ±250mA  
 Peak Current  
 (Pulsed at 1ms, 10% duty cycle) ..... ±500mA  
 Storage Temperature..... -65°C to +150°C  
 Power Dissipation (QFN10 <sup>(2)</sup> <sup>(3)</sup>) ..... 208mW

#### Notes:

- 1) Signals on NC, or COM or IN exceeding V+ will be clamped by internal diodes. Limit forward diode current to maximum current ratings.
- 2) Derate 4.0mW/°C above 70°C.
- 3) All leads welded or soldered to PC Board.

## ELECTRICAL CHARACTERISTICS

V+=3V, ±10%, V<sub>IN</sub>=0.4 or 1.65V, unless otherwise noted.

Parameter	Symbol	Condition	Min	Typ	Max	Units	
<b>Analog Switch</b>							
Analog Signal Range	V <sub>analog</sub>	r <sub>DS(on)</sub> , T <sub>A</sub> = -40°C to +85°C	0		V+	V	
On-Resistance	r <sub>DS(on)</sub>	V+=2.7V, I <sub>NO/NC</sub> =100mA, V <sub>COM</sub> =0.5V	T <sub>A</sub> = +25°C	0.28	0.45	Ω	
		V+=2.7V, I <sub>NO/NC</sub> =100mA, V <sub>COM</sub> =1.5V					
		V+=2.7V, I <sub>NO/NC</sub> =100mA, V <sub>COM</sub> =0.5V	T <sub>A</sub> = -40°C to +85°C	0.30			
		V+=2.7V, I <sub>NO/NC</sub> =100mA, V <sub>COM</sub> =1.5V					
		V+=5.5V, I <sub>NO/NC</sub> =100mA, V <sub>COM</sub> =0.9V	T <sub>A</sub> = +25°C	0.20	0.30		
		V+=5.5V, I <sub>NO/NC</sub> =100mA, V <sub>COM</sub> =2.5V		0.18			
		V+=5.5V, I <sub>NO/NC</sub> =100mA, V <sub>COM</sub> =0.9V	T <sub>A</sub> = -40°C to +85°C	0.25			
		V+=5.5V, I <sub>NO/NC</sub> =100mA, V <sub>COM</sub> =2.5V					
r <sub>ON</sub> Match	Δr <sub>on</sub>	V+=2.7V, I <sub>NO/NC</sub> =100mA, V <sub>COM</sub> =0.5V/1.5V	T <sub>A</sub> = +25°C	0.01	0.02		
		V+=5.5V, I <sub>NO/NC</sub> =100mA, V <sub>COM</sub> =0.9V/2.5V					
r <sub>ON</sub> Flatness	r <sub>ON</sub> Flatness	V+=2.7V, I <sub>NO/NC</sub> =100mA, V <sub>COM</sub> =0.5V/1.5V					
Switch Off Leakage Current	I <sub>NO/NC(off)</sub>	V+=5.5V, V <sub>NO/NC</sub> =0.3V/4.0V, V <sub>COM</sub> =4.0V/0.3V	T <sub>A</sub> = +25°C	-40		40	nA
			T <sub>A</sub> = -40°C to +85°C	-100		100	
	T <sub>A</sub> = +25°C		-40		40		
	T <sub>A</sub> = -40°C to +85°C		-100		100		
Channel-On Leakage Current	I <sub>COM(on)</sub>	V+=5.5V, V <sub>NO/NC</sub> =V <sub>COM</sub> =4.0V/0.3V	T <sub>A</sub> = +25°C	-40		40	
			T <sub>A</sub> = -40°C to +85°C	-150		150	
<b>Digital Control</b>							
Input High Voltage	V <sub>INH</sub>		T <sub>A</sub> = -40°C to +85°C	1.65		V	
Input Low Voltage	V <sub>INL</sub>						0.4
Input Capacitance	C <sub>IN</sub>				6		pF
Input Current	I <sub>INL</sub> or I <sub>INH</sub>			V <sub>IN</sub> =0 or V+	-1		1

**ELECTRICAL CHARACTERISTICS (continued)**
**V+=3V, ±10%, V<sub>IN</sub>=0.4 or 1.65V, unless otherwise noted.**

Parameter	Symbol	Condition	Min	Typ	Max	Units		
<b>Dynamic Characteristics</b>								
Break-Before-Make Time	t <sub>BBM</sub>	V+=3.6V, V <sub>NO</sub> /V <sub>NC</sub> =1.5V, R <sub>L</sub> =50Ω, C <sub>L</sub> =35pF	T <sub>A</sub> = +25°C		10		ns	
Turn-On Time	t <sub>ON</sub>				24	36		
Turn-Off Time	t <sub>OFF</sub>		T <sub>A</sub> = -40°C to +85°C			40		
			T <sub>A</sub> = +25°C		20	30		
Enable Turn-On Time MP2736 ( $\overline{\text{EN}}$ )	t <sub>ON(EN)</sub>		T <sub>A</sub> = -40°C to +85°C			35		
			T <sub>A</sub> = +25°C		24	36		
Enable Turn-Off Time MP2736 ( $\overline{\text{EN}}$ )	t <sub>OFF(EN)</sub>		T <sub>A</sub> = -40°C to +85°C			40		
			T <sub>A</sub> = +25°C		20	30		
Off-Isolation <sup>(4)</sup>	OIRR	R <sub>L</sub> =50Ω, C <sub>L</sub> =5pF, f=100kHz			-70		dB	
Crosstalk <sup>(4)</sup>	XTALK					-70		dB
3dB Bandwidth				R <sub>L</sub> =50Ω, C <sub>L</sub> =5pF			50	
NO, NC Off Capacitance <sup>(4)</sup>	C <sub>NO(off)</sub>	V <sub>IN</sub> =0V, or V+, f=1MHz	T <sub>A</sub> = +25°C		55		pF	
	C <sub>NC(off)</sub>				55			
Channel On Capacitance <sup>(4)</sup>	C <sub>NO(on)</sub>					130		
	C <sub>NC(on)</sub>					130		
<b>Power Supply</b>								
Power Supply Range	V+			1.65		5.5	V	
Power Supply Current	I+	V <sub>IN</sub> =0 or V+	T <sub>A</sub> = -40°C to +85°C	-1		1	μA	

**Note:**

- 4) Guarantee by design, not subjected to production test.

## PIN FUNCTIONS

( MP2735DQG) Pin #	( MP2736DQG) Pin #	Name	Description
1	1	V+	Supply Voltage
2	2	NO1	Normally open I/O port of switch1
3	3	COM1	Common I/O port for NC and NO channels of switch1
4	4	IN1	Channel select signal for switch1. IN1 high, NO1 channel is selected. Otherwise, NC1 channel is selected in default. For MP2736, IN1 controls both switch1 and switch2
5	5	NC1	Normally closed I/O port of switch1
6	6	GND	Ground
7	7	NC2	Normally closed I/O port of switch2
8		IN2	Channel select signal for switch2. IN2 high, NO2 channel is selected. Otherwise, NC2 channel is selected in default
	8	$\overline{\text{EN}}$	Enable for two channels, active low
9	9	COM2	Common I/O port for NC and NO channels of switch2
10	10	NO2	Normally open I/O port of switch2

## TYPICAL PERFORMANCE CHARACTERISTICS

$T_A = +25^\circ\text{C}$ , unless otherwise noted.

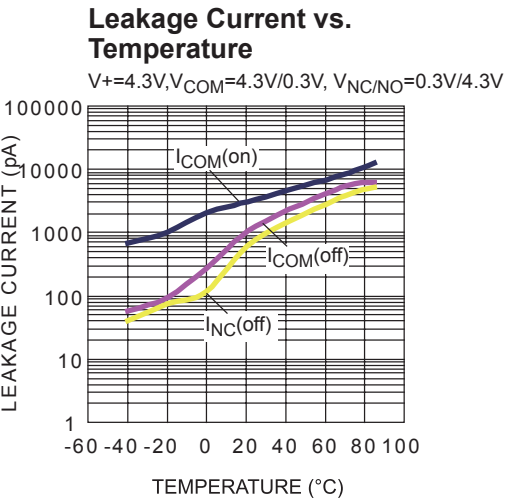
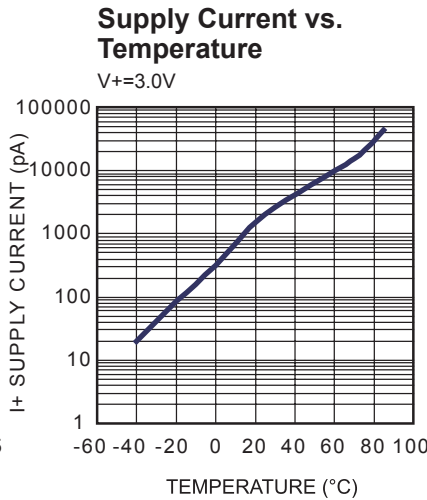
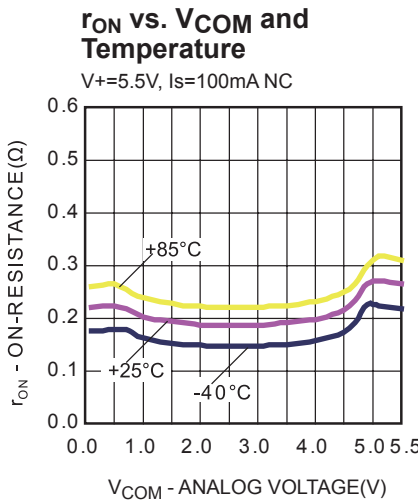
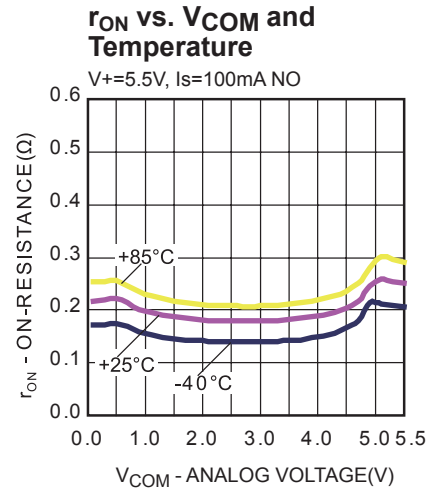
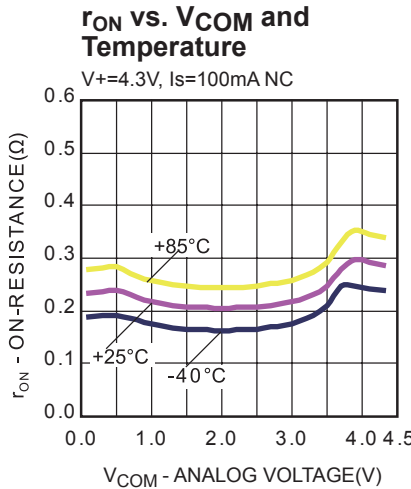
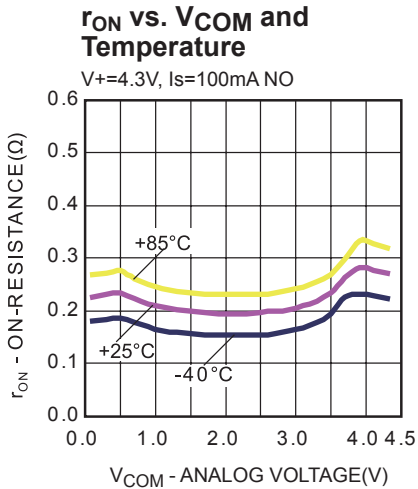
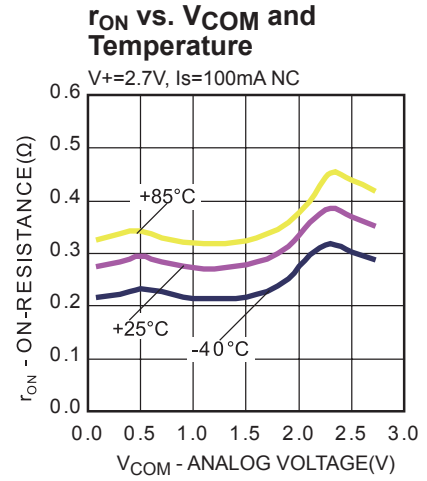
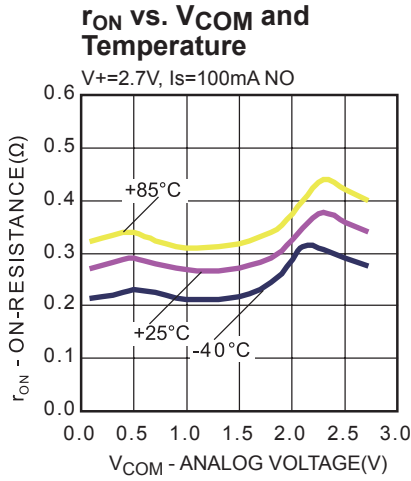
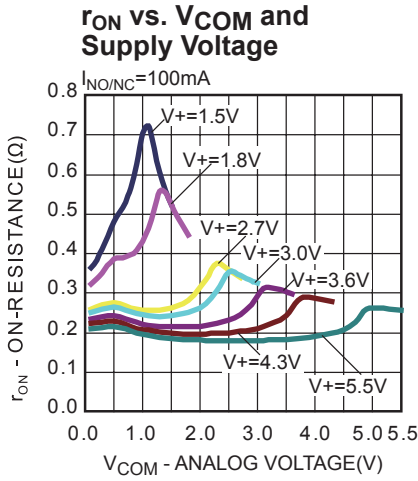

**TYPICAL PERFORMANCE CHARACTERISTICS (continued)**

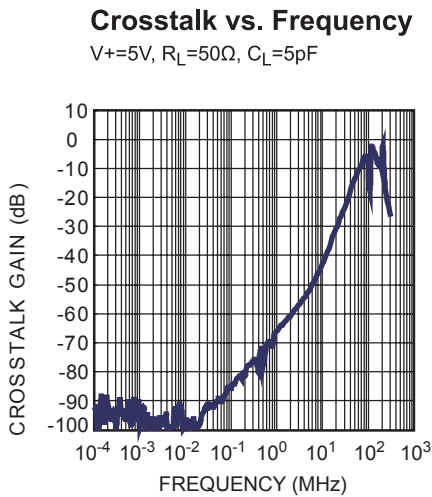
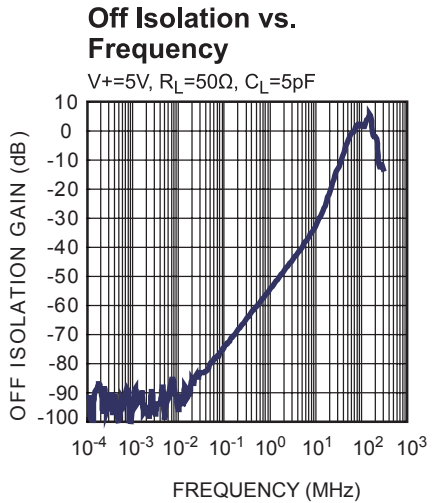
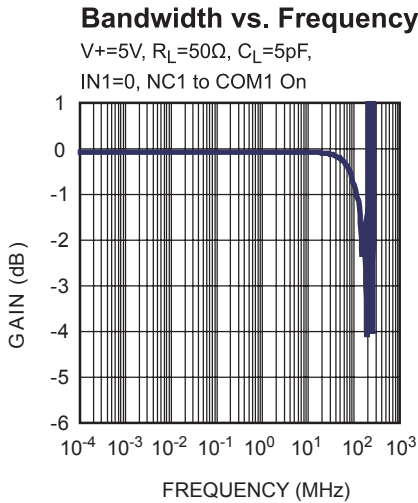
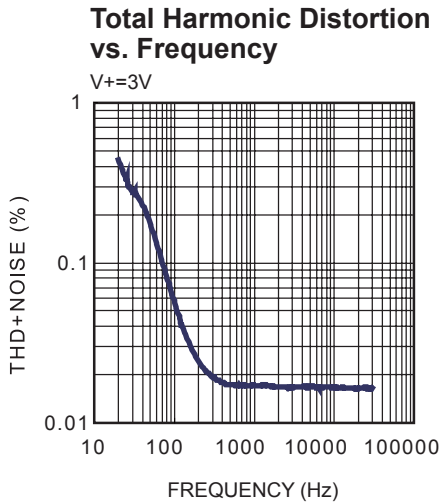
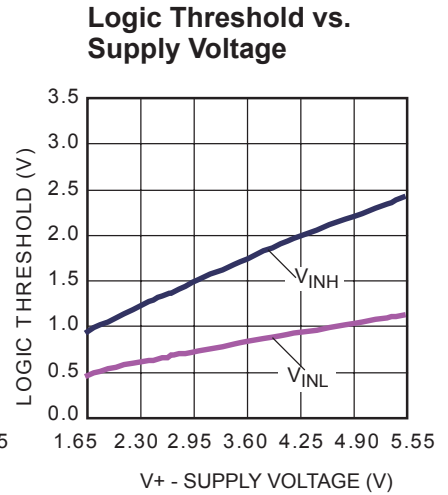
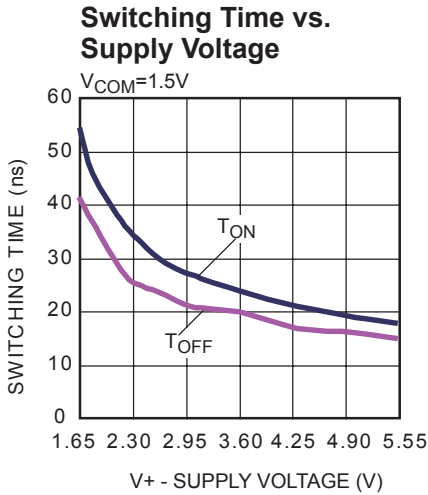
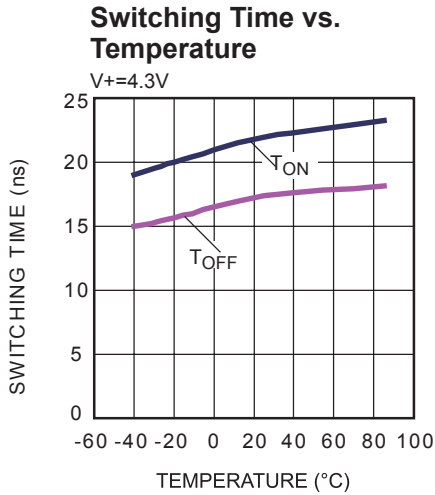
 T<sub>A</sub> = +25°C, unless otherwise noted.

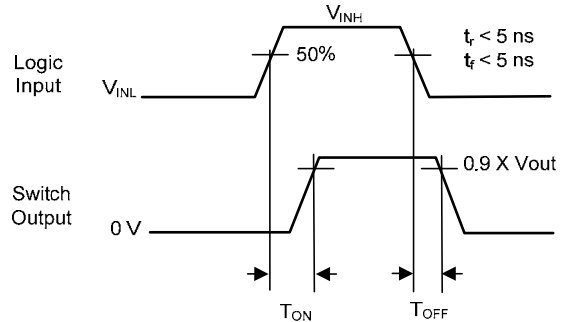
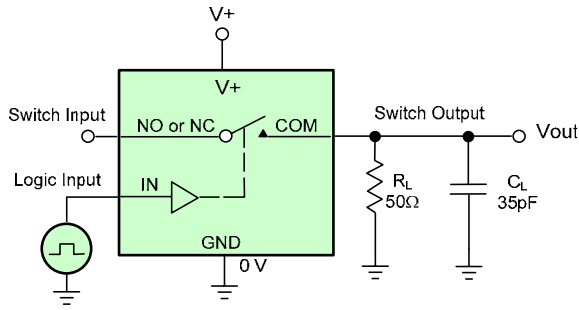
**TEST CIRCUITS**

$C_L$  (includes fixture and stray capacitance)

$$V_{out} = V_{COM} \left( \frac{R_L}{R_L + R_{ON}} \right)$$

Logic "1" = Switch on  
Logic input waveforms inverted for switches that have the opposite logic sense.

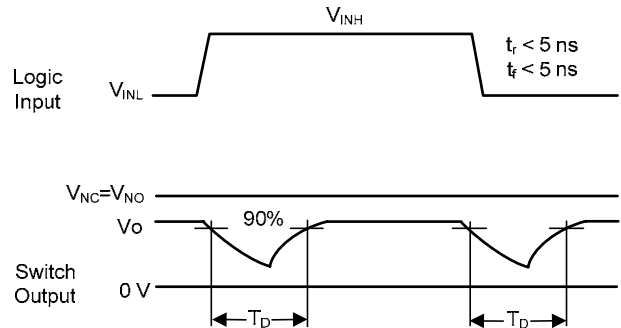
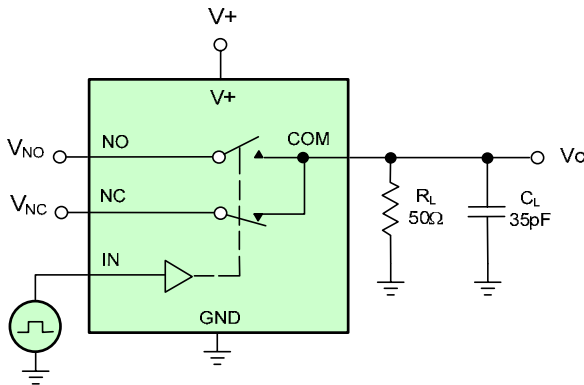
**Figure 1 — Switching Time**

$C_L$  (includes fixture and stray capacitance)

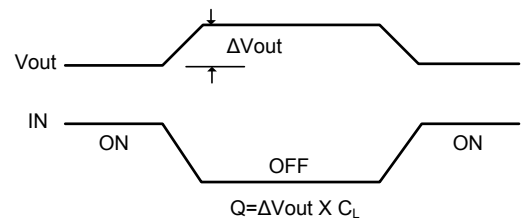
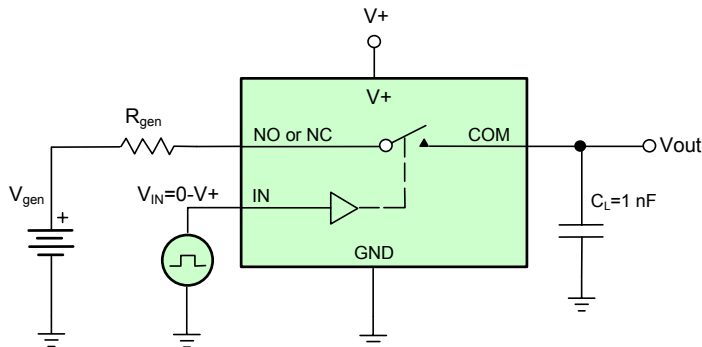
**Figure 2 — Break-Before-Make Interval**

IN depends on switch configuration: input polarity determined by sense of switch.

**Figure 3 — Charge Injection**



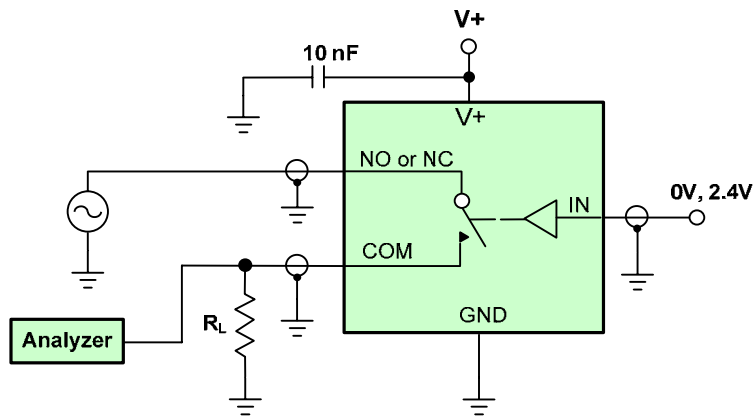

$$\text{Off Isolation} = 20 \log \frac{V_{\text{COM}}}{V_{\text{NO/NC}}}$$

Figure 4 — Off-Isolation

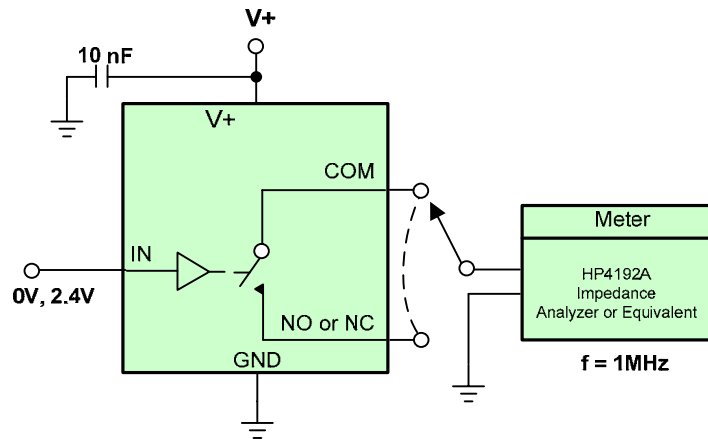
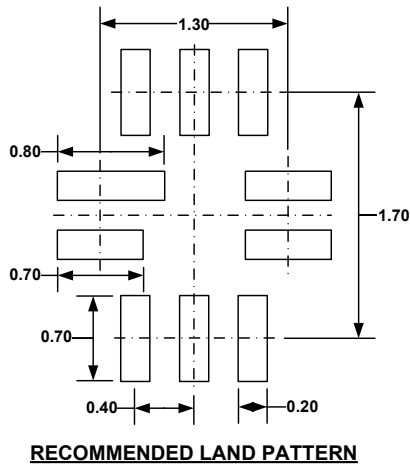
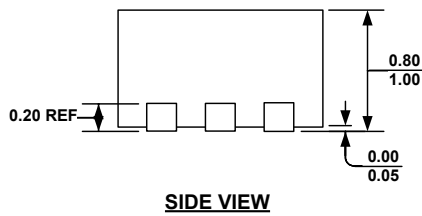
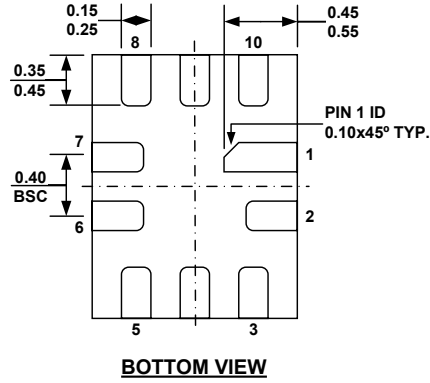
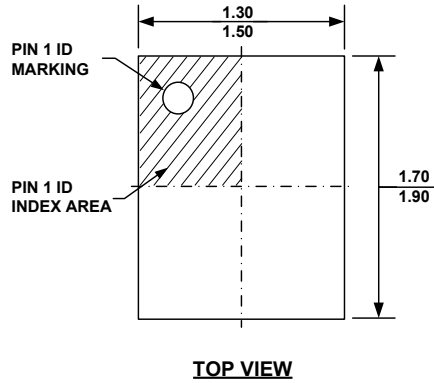

Figure 5 — Channel Off/On Capacitance

## PACKAGE INFORMATION

### PACKAGE OUTLINE DRAWING FOR 10L FCQFN (1.4x1.8mm) MF-PO-D-0084 revision 0.0



**NOTE:**

- 1) ALL DIMENSIONS ARE IN MILLIMETERS.
- 2) EXPOSED PADDLE SIZE DOES NOT INCLUDE MOLD FLASH.
- 3) LEAD COPLANARITY SHALL BE 0.10 MILLIMETER MAX.
- 4) JEDEC REFERENCE IS MO-220.
- 5) DRAWING IS NOT TO SCALE.

**NOTICE:** The information in this document is subject to change without notice. Please contact MPS for current specifications. Users should warrant and guarantee that third party Intellectual Property rights are not infringed upon when integrating MPS products into any application. MPS will not assume any legal responsibility for any said applications.



Компания «ЭлектроПласт» предлагает заключение долгосрочных отношений при поставках импортных электронных компонентов на взаимовыгодных условиях!

Наши преимущества:

- Оперативные поставки широкого спектра электронных компонентов отечественного и импортного производства напрямую от производителей и с крупнейших мировых складов;
- Поставка более 17-ти миллионов наименований электронных компонентов;
- Поставка сложных, дефицитных, либо снятых с производства позиций;
- Оперативные сроки поставки под заказ (от 5 рабочих дней);
- Экспресс доставка в любую точку России;
- Техническая поддержка проекта, помощь в подборе аналогов, поставка прототипов;
- Система менеджмента качества сертифицирована по Международному стандарту ISO 9001;
- Лицензия ФСБ на осуществление работ с использованием сведений, составляющих государственную тайну;
- Поставка специализированных компонентов (Xilinx, Altera, Analog Devices, Intersil, Interpoint, Microsemi, Aeroflex, Peregrine, Syfer, Eurofarad, Texas Instrument, Miteq, Cobham, E2V, MA-COM, Hittite, Mini-Circuits, General Dynamics и др.);

Помимо этого, одним из направлений компании «ЭлектроПласт» является направление «Источники питания». Мы предлагаем Вам помощь Конструкторского отдела:

- Подбор оптимального решения, техническое обоснование при выборе компонента;
- Подбор аналогов;
- Консультации по применению компонента;
- Поставка образцов и прототипов;
- Техническая поддержка проекта;
- Защита от снятия компонента с производства.



#### Как с нами связаться

**Телефон:** 8 (812) 309 58 32 (многоканальный)

**Факс:** 8 (812) 320-02-42

**Электронная почта:** [org@eplast1.ru](mailto:org@eplast1.ru)

**Адрес:** 198099, г. Санкт-Петербург, ул. Калинина, дом 2, корпус 4, литера А.