

## HEDG-9000 Series

Codewheel for use with Avago Technologies  
Ultra-precision 17-Bit Absolute Single Turn Encoder  
Encoder Modules AEAT-9000 series



## Data Sheet



### Description

Avago Technologies offers a codewheel designed specifically for use with the AEAT-9000 series encoder modules. The HEDG-9000 Series codewheel is suitable for many environments, applications, and budgets. Made from glass the HEDG-9000 codewheel has a resolution of 2048 CPR and an optical radius of 17.5 mm.

**Note:** Avago Technologies encoders are not recommended for use in safety critical applications, e.g., ABS braking systems, power steering, life support systems and critical care medical equipment. Avago's products and software are not specifically designed, manufactured or authorized for sale as parts, components or assemblies for the planning, construction, maintenance or direct operation of a nuclear facility or for use in medical devices or applications. Customer is solely responsible, and waives all rights to make claims against Avago or its suppliers, for all loss, damage, expense or liability in connection with such use. Please contact sales representative if more clarification is needed.

### Features

- Codewheel in Glass.
- Cost Effective
- Resolutions of 2048 CPR
- For Use with AEAT-9000 Series Encoders
- Lead Free

### Applications

Typical applications include

- Rotary applications up to 17 bits/360° absolute position
- Integration into servo motors
- Industrial and maritime valve control
- High precision test and measurement machines
- Industrial and factory automation equipments
- Textile, woodworking & packaging machineries
- Nacelle & blades control in wind turbine

### Absolute Maximum Ratings

Parameter	Symbol	Min.	Typical	Max.	Units
Storage Temperature	T <sub>S</sub>	-40		115	°C
Operating Temperature	T <sub>A</sub>	-40		115	°C
Velocity				15000	RPM
Shaft Axial Play		-0.05		0.05	mm
Shaft Eccentricity( inclusive module radial play)				0.05	mm TIR

### Recommended Operating Conditions

Description	Min.	Typical	Max.	Units
Maximum Count Frequency			500	kHz
Shaft Axial Play	-0.05		0.05	mm
Shaft Eccentricity( inclusive module radial play)			0.05	mm TIR

## Codewheel installation instructions

1. Place codewheel on shaft
2. Set codewheel height using Set Height Tool
  - a) Place the set height tool on the Module mounting surface, where the 2 guide pins being inserted into the 2 mounting holes;
  - b) Push the codewheel toward the set height tool until touching the tool. The codewheel is now at the proper height;
  - c) Tighten both codewheel set screws.
3. Remove the set height tool
4. Install encoder module.

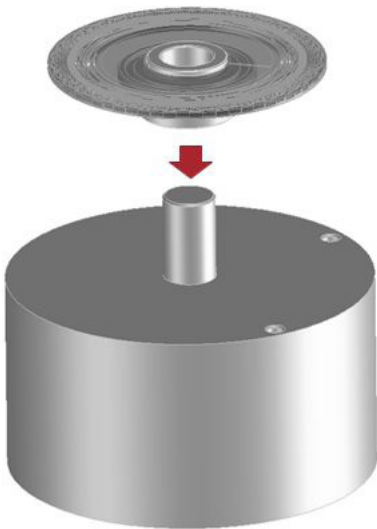

Figure 1a. Mount the CW with hub to shaft

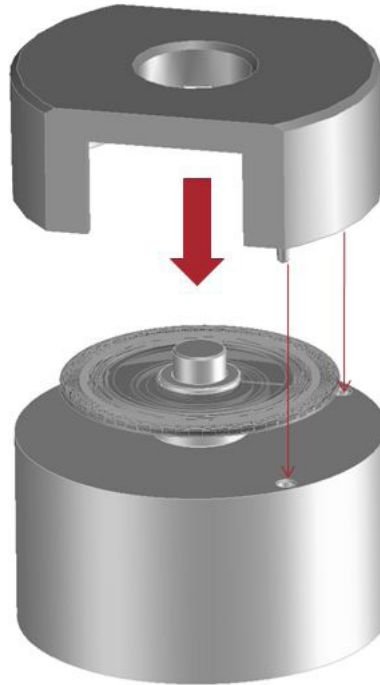

Figure 1b. Place the set height tool

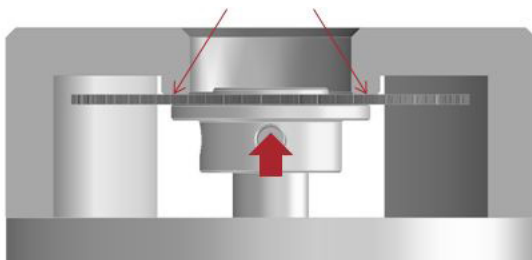

Figure 1c. Push the CW until touching the set height tool



Figure 1d. Tighten the set screws

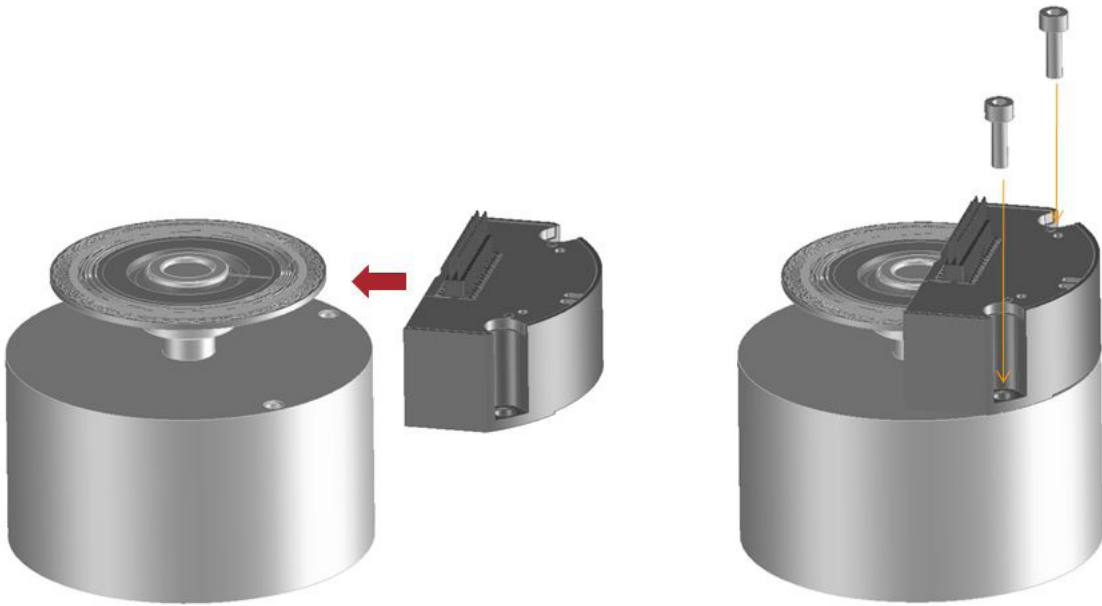
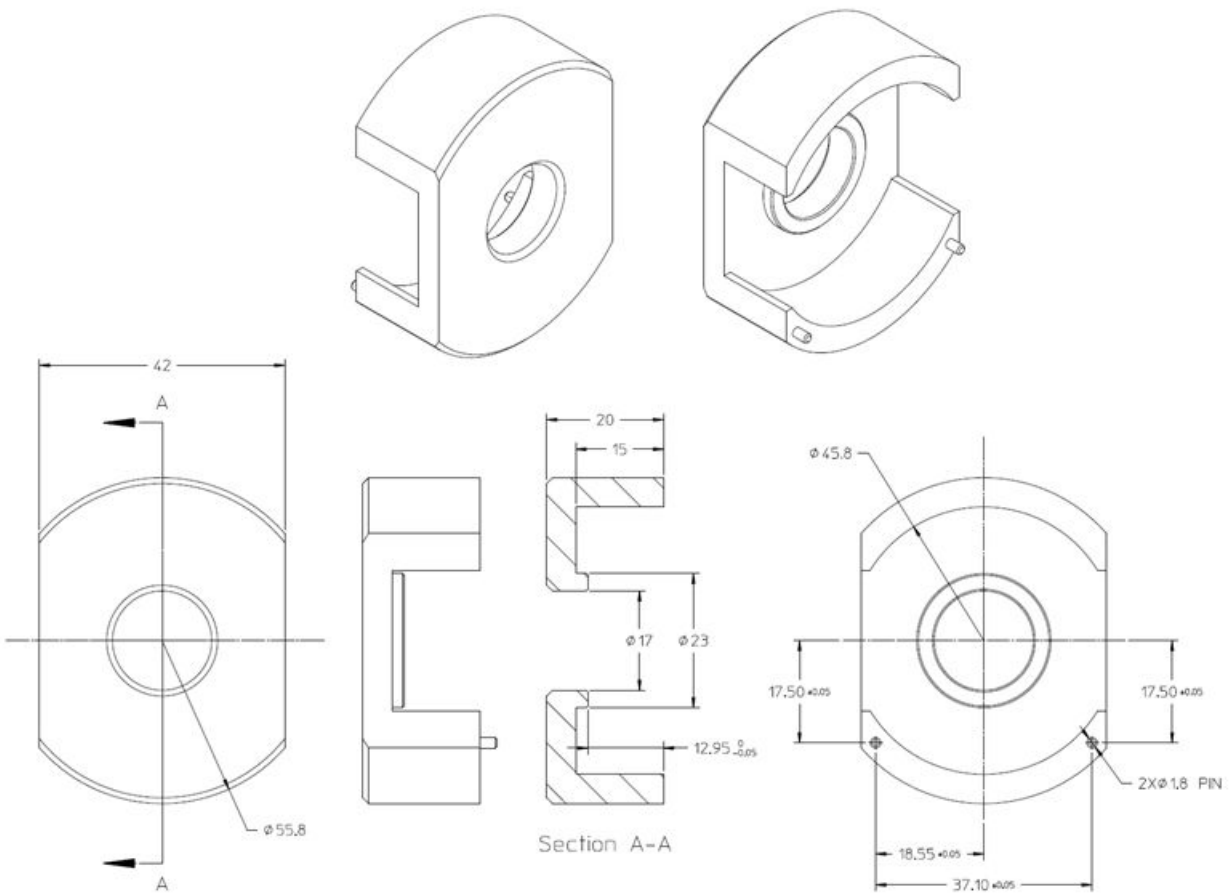

Figure 1e. Remove the set height tool and install encoder module

### Recommended set height tool design



- Notes:
1. All dimensions are in millimeter.
  2. Tolerance:  $X.X \pm 0.20$  mm.

Figure 2. Recommended Set Height Tool Design and Dimension

**Codewheel Dimension**

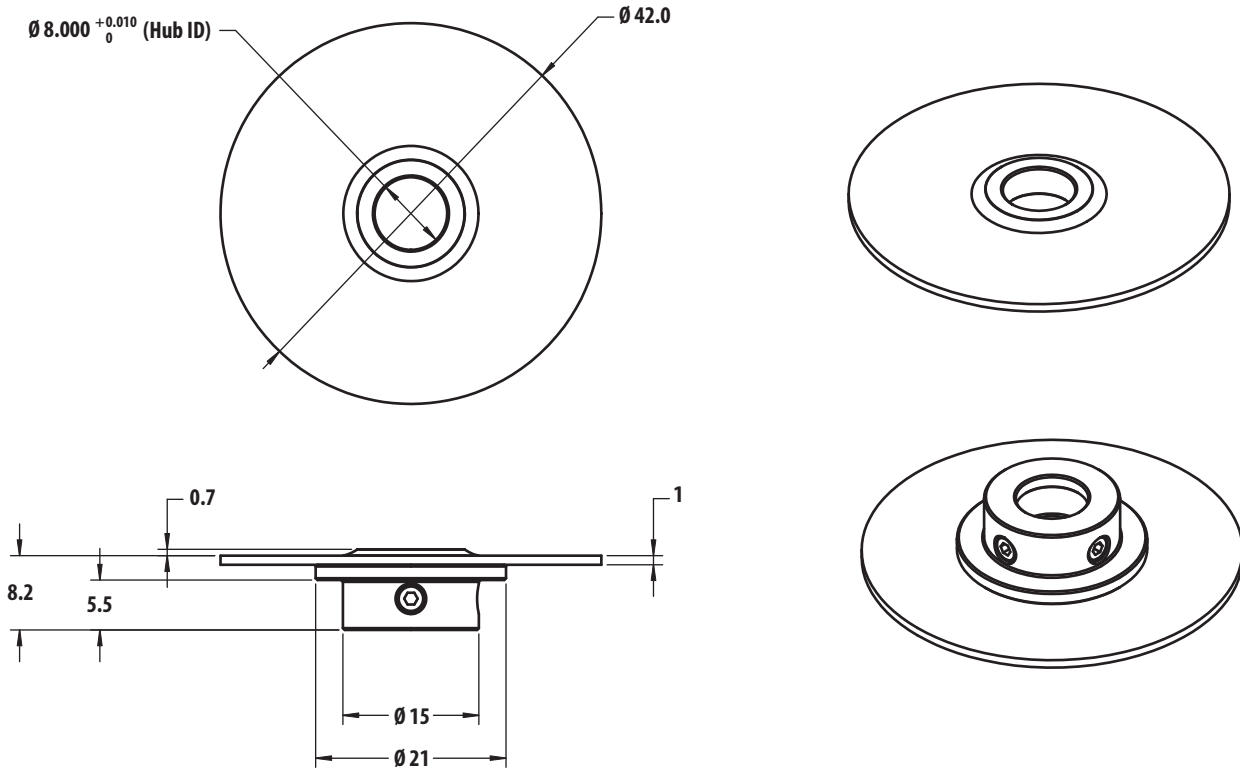

- Notes:
1. All dimensions are in millimeter.
  2. Tolerance:  $X.X \pm 0.20$  mm.

**Figure 3a. Dimension for codewheel with hub**

**HEDG-9000-H14**

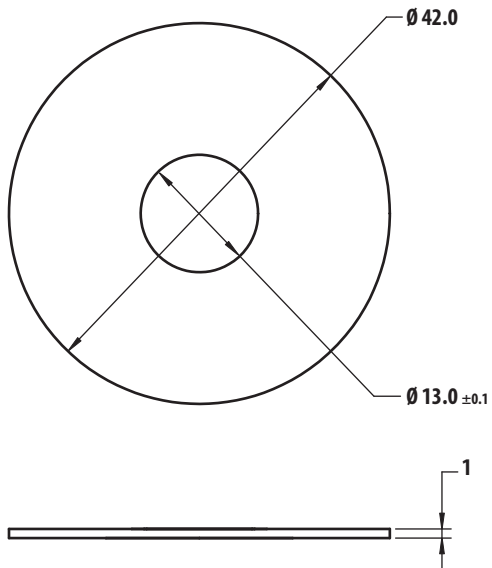

- Notes:
1. All dimensions are in millimeter.
  2. Tolerance:  $X.X \pm 0.20$  mm.

**Figure 3b. Bare Codewheel Dimension**

## Ordering Information

HEDG - 9000 - H 1

3 – Codewheel with hub  
4 – Bare Codewheel

For product information and a complete list of distributors, please go to our web site: [www.avagotech.com](http://www.avagotech.com)

Avago, Avago Technologies, and the A logo are trademarks of Avago Technologies in the United States and other countries.  
Data subject to change. Copyright © 2005-2011 Avago Technologies. All rights reserved.  
AV02-3147EN - August 25, 2011

**AVAGO**  
TECHNOLOGIES



Компания «ЭлектроПласт» предлагает заключение долгосрочных отношений при поставках импортных электронных компонентов на взаимовыгодных условиях!

Наши преимущества:

- Оперативные поставки широкого спектра электронных компонентов отечественного и импортного производства напрямую от производителей и с крупнейших мировых складов;
- Поставка более 17-ти миллионов наименований электронных компонентов;
- Поставка сложных, дефицитных, либо снятых с производства позиций;
- Оперативные сроки поставки под заказ (от 5 рабочих дней);
- Экспресс доставка в любую точку России;
- Техническая поддержка проекта, помощь в подборе аналогов, поставка прототипов;
- Система менеджмента качества сертифицирована по Международному стандарту ISO 9001;
- Лицензия ФСБ на осуществление работ с использованием сведений, составляющих государственную тайну;
- Поставка специализированных компонентов (Xilinx, Altera, Analog Devices, Intersil, Interpoint, Microsemi, Aeroflex, Peregrine, Syfer, Eurofarad, Texas Instrument, Miteq, Cobham, E2V, MA-COM, Hittite, Mini-Circuits, General Dynamics и др.);

Помимо этого, одним из направлений компании «ЭлектроПласт» является направление «Источники питания». Мы предлагаем Вам помощь Конструкторского отдела:

- Подбор оптимального решения, техническое обоснование при выборе компонента;
- Подбор аналогов;
- Консультации по применению компонента;
- Поставка образцов и прототипов;
- Техническая поддержка проекта;
- Защита от снятия компонента с производства.



#### Как с нами связаться

**Телефон:** 8 (812) 309 58 32 (многоканальный)

**Факс:** 8 (812) 320-02-42

**Электронная почта:** [org@eplast1.ru](mailto:org@eplast1.ru)

**Адрес:** 198099, г. Санкт-Петербург, ул. Калинина, дом 2, корпус 4, литера А.