



SEK 19 male low profile connector solder angled



General information

Design	IEC 60603-13		
No. of contacts	6,10,14,16,20,26,30,34,40,50,60,64		
Contact spacing	2,54 mm x 2,54 mm		
Test voltage Ur.m.s	1 kV		
Working voltage	500 V for pollution degree 1		
Contact resistance	max. 20mOhm		
Insulation resistance	min. 10 ⁹ Ohm		
Working current acc. to IEC 60512-2	See derating diagram		
Temperature range	-55°C ... +125°C		
Termination technology	solder		
Clearance & creepage distance	min. 0,5 mm clearance min. 0,56 creepage		
Insertion and withdrawal forces	6-pole max. 12N for PL1-2 / 18N for PL3	; 30-pole max. 60N for PL1-2 / 90N for PL3	
	10-pole max. 20N for PL1-2 / 30N for PL3	; 34-pole max. 68N for PL1-2 / 102N for PL3	
	14-pole max. 28N for PL1-2 / 42 for PL3	; 40-pole max. 80N for PL1-2 / 120N for PL3	
	16-pole max. 32N for PL1-2 / 48N for PL3	; 50-pole max. 100N for PL1-2 / 150N for PL3	
	20-pole max. 40N for PL1-2 / 60N for PL3	; 60-pole max. 120N for PL1-2 / 180N for PL3	
	26-pole max. 52N for PL1-2 / 78N for PL3	; 64-pole max. 128N for PL1-2 / 192N for PL3	
Mating cycles	S4 surface treatment	Au over PdNi (min. 0,76 µm)	
	PL 1 acc. to IEC 60603-13	500 mating cycles	10 days gas test
	PL 2 acc. to IEC 60603-13	250 mating cycles	4 days gas test
UL file	PL 3 acc. to IEC 60603-13	50 mating cycles	No gas test
	UL file	No	
	RoHS - compliant	Yes	
Leadfree	Yes		
Hot plugging	No		

Insulator material

Material	PCT (thermoplastics, glass fiber reinforcement 30%)		
Color	Black (RAL 7001) or beige		
UL classification	UL94-V0		
Material group acc. IEC 60664-1	II (400 < CTI < 600)		
NF F 16-101 classification	No		

Contact material

Contact material	Copper alloy		
Plating termination zone	Sn over Ni		
Plating contact sliding side	Au or Au over PdNi (according to performance level)		

Derating diagram acc to IEC 60512-2 (Current carrying capacity)

The current carrying capacity is limited by maximum temperature of materials for inserts and contacts including terminals. The current capacity-curve is valid for continuous, not interrupted current-loaded contacts of connectors when simultaneous power on all contacts is given without exceeding the maximum temperature. Control and test procedures according to DIN IEC 60512.

- 1) Temperature rise
- 2) Derating
- 3) Derating curve at I max x 0.8(IEC 60512-2)

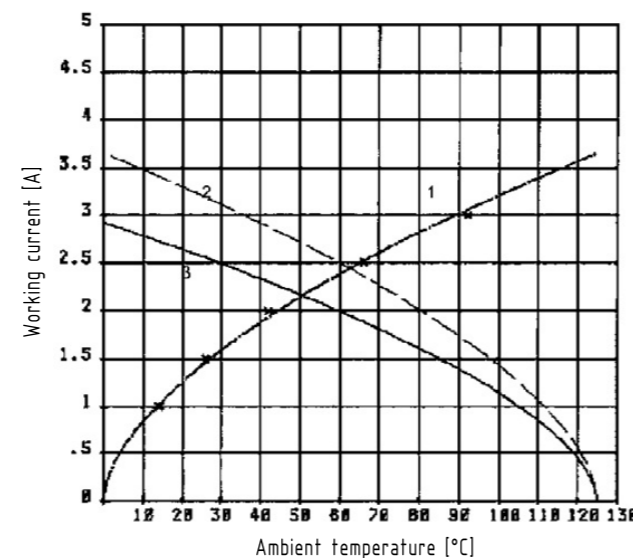

Soldering instructions

THR (Through Hole Reflow) connectors are designed to be used in a reflow oven. THR connectors can also be used together with SMD (Surface Mount Device) components in a reflow oven. In this process, called as well "Pin in hole intrusive reflow", the connectors are inserted into plated through holes in a comparable way to conventional component mounting. All other components can be assembled on the PCB surface.

The length of the connector contacts should be such that they protrude by no more than 1,5 millimeters after insertion to the PCB. Each contact collects solder on its tip as it penetrates the solder paste in the hole. So if the contact is too long, this solder would no longer be able to reflow back into the plated through hole by capillary action during the soldering process, therefore the quality of the soldered connection would suffer as a result.

Quantity of solder paste

Before the components are assembled, solder paste must be applied to all solder pads (for connecting surface-mount components) and the plated through holes. To ensure that the plated through holes are completely filled, significantly more solder paste must be applied than traditional solder pads on the PCB. The following rule of thumb has proved valuable in practice:

$$V_{paste} = 2(VH - VP)$$

in which:

V_{paste} = Required volume of solder paste

VH = Volume of plated through hole

VP = Volume of the connector termination in the hole

comment: the multiplier "2" compensates for solder paste shrinkage during soldering. For this purpose, it was assumed that 50% of the paste consists of the actual solder, the other 50% being soldering aids.

Cross section of solder terminations

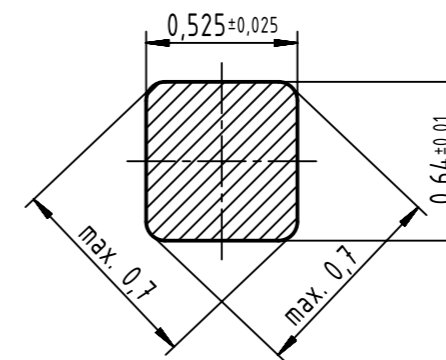

Packaging material (only for plastic tray)

Material	Polystyrol
Color	Yellow
Standardization	acc. to DIN EN / IEC 61340-5-1 and ANSI / ESD S541-2003

- Safe protection for electronic components against electrostatic charges

	All rights reserved	Created by	Inspected by	Standardisation	Date	State
	Department EC PD - DE	STORCK	LEHNERT	HOFFMANN	2018-02-13	Final Release
Title						Doc-Key / ECM-Nr.
SEK 19 male low profile connector solder angled						100555122/UGD/001/F
Type						500000131326
Number						Rev.
DS						F
Page						1/2



SEK 19 male low profile connector solder angled



Tape layout & packaging

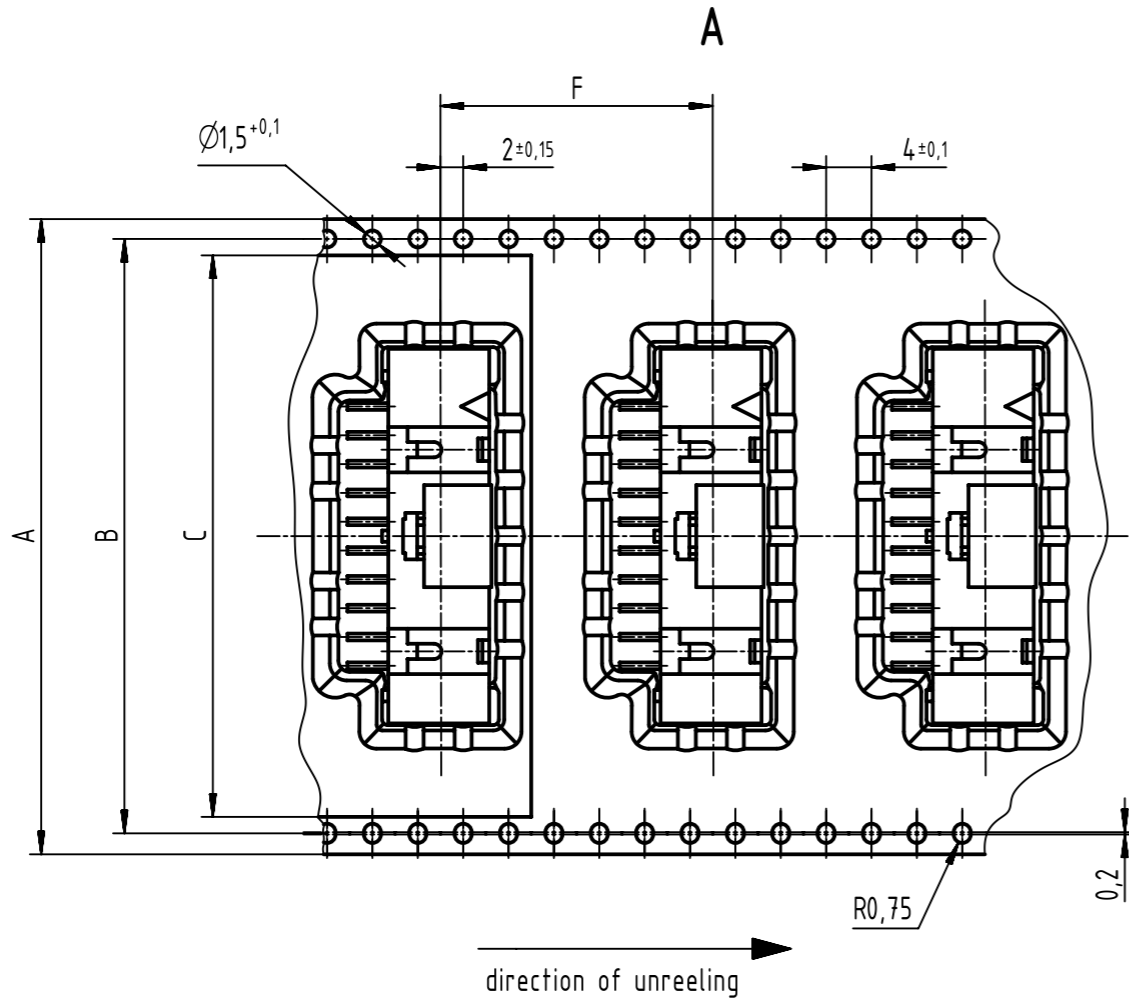

colour	Part number
beige	0919 5xx x32x 740
black	0919 5xx x32x 741

40	72	68,4	65,5	73	78	24	14	280	16
34	72	68,4	65,5	73	78	24	14	280	16
30	56	52,4	49,5	57	62	24	14	280	16
26	56	52,4	49,5	57	62	24	14	280	16
20	56	52,4	49,5	57	62	24	14	280	16
16	44	40,4	37,5	45	50	24	14	280	16
14	44	40,4	37,5	45	50	24	14	280	16
10	44	40,4	37,5	45	50	24	14	280	16
6	32	28,4	25,5	33	38	24	14	280	16
contacts	A	B	C	D	E	F	-trailer- number of empty cavities	number of connector per reel	-leader- number of empty cavities

Reel dimension

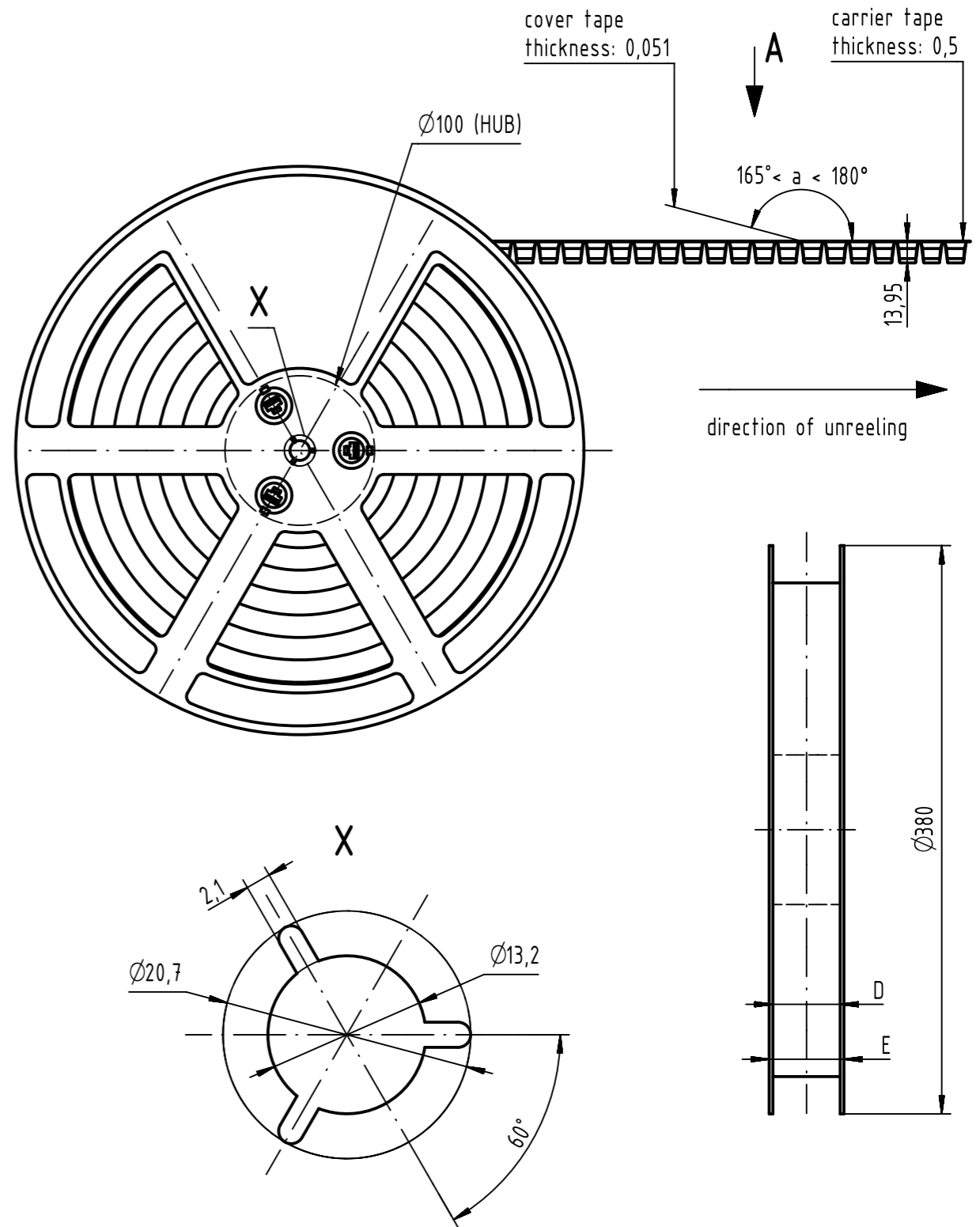

All Dimensions in mm
Original Size DIN A3

Scale
1:1

Free size tol.

Ref.

Sub.



All rights reserved
Department EC PD - DE

Created by
STORCK

Inspected by
LEHNERT

Standardisation
HOFFMANN

Date
2018-02-13

State
Final Release

Title
SEK 19 male low profile connector solder angled

Doc-Key / ECM-Nr.
100555122/UGD/001/F
500000131326

Type
DS

Number
09191230201

Rev.
F

Page
2/2

HARTING Electronics GmbH
D-32339 Espelkamp

Mouser Electronics

Authorized Distributor

Click to View Pricing, Inventory, Delivery & Lifecycle Information:

HARTING:

[09195067323](#) [09195205323](#) [09195207323](#) [09195267323](#) [09195407323](#) [09195507323](#) [09195607323](#)
[09195646323](#) [09195105323](#) [09195347323](#) [09195066323](#) [09195106323](#) [09195346323](#) [09195107323](#) [09195147323](#)
[09195166323](#) [09195167323](#) [09195266323](#) [09195146323](#) [09195506323](#) [09195206323](#)



Компания «ЭлектроПласт» предлагает заключение долгосрочных отношений при поставках импортных электронных компонентов на взаимовыгодных условиях!

Наши преимущества:

- Оперативные поставки широкого спектра электронных компонентов отечественного и импортного производства напрямую от производителей и с крупнейших мировых складов;
- Поставка более 17-ти миллионов наименований электронных компонентов;
- Поставка сложных, дефицитных, либо снятых с производства позиций;
- Оперативные сроки поставки под заказ (от 5 рабочих дней);
- Экспресс доставка в любую точку России;
- Техническая поддержка проекта, помощь в подборе аналогов, поставка прототипов;
- Система менеджмента качества сертифицирована по Международному стандарту ISO 9001;
- Лицензия ФСБ на осуществление работ с использованием сведений, составляющих государственную тайну;
- Поставка специализированных компонентов (Xilinx, Altera, Analog Devices, Intersil, Interpoint, Microsemi, Aeroflex, Peregrine, Syfer, Eurofarad, Texas Instrument, Miteq, Cobham, E2V, MA-COM, Hittite, Mini-Circuits, General Dynamics и др.);

Помимо этого, одним из направлений компании «ЭлектроПласт» является направление «Источники питания». Мы предлагаем Вам помощь Конструкторского отдела:

- Подбор оптимального решения, техническое обоснование при выборе компонента;
- Подбор аналогов;
- Консультации по применению компонента;
- Поставка образцов и прототипов;
- Техническая поддержка проекта;
- Защита от снятия компонента с производства.



Как с нами связаться

Телефон: 8 (812) 309 58 32 (многоканальный)

Факс: 8 (812) 320-02-42

Электронная почта: org@eplast1.ru

Адрес: 198099, г. Санкт-Петербург, ул. Калинина, дом 2, корпус 4, литера А.