

### Features

- 802.11a + b/g and MIMO Applications
- Test and Measurement and Low/Medium Power Telecommunication Applications up to 8.0 GHz
- Broadband Performance: DC - 8.0 GHz
- Low Insertion Loss: 0.5 dB from 2.0 - 6.0 GHz
- High Isolation: 30 dB from 2.0 - 6.0 GHz
- Fast Settling for Low Gate Lag Requirements
- Lead-Free 2 mm 8-Lead PDFN Package
- 100% Matte Tin Plating over Copper
- Halogen-Free "Green" Mold Compound
- RoHS Compliant\* and 260°C Reflow Compatible

### Description

M/A-COM's MASW-007107 is a broadband GaAs pHEMT MMIC SPDT switch in a lead-free 2 mm 8-lead PDFN package. Typical applications are for WLAN IEEE 802.11a + b/g, and MIMO. Other applications include test equipment requiring ultra fast switching speeds. Designed for low insertion loss, this SPDT switch maintains low loss up to 8.0 GHz.

The MASW-007107 is fabricated using a 0.5 micron gate length GaAs pHEMT process. The process features full passivation for performance and reliability.

### Ordering Information <sup>1,2</sup>

Part Number	Package
MASW-007107-TR3000	3000 piece reel
MASW-007107-000SMB	Sample Test Board
MASW-007107-000DIE <sup>3</sup>	Separated die on grip ring
MASW-007107-0GPDIE	100 piece gel pack

1. Reference Application Note M513 for reel size information.
2. All sample boards include 5 loose parts.
3. Die quantity varies.

### Functional Schematic

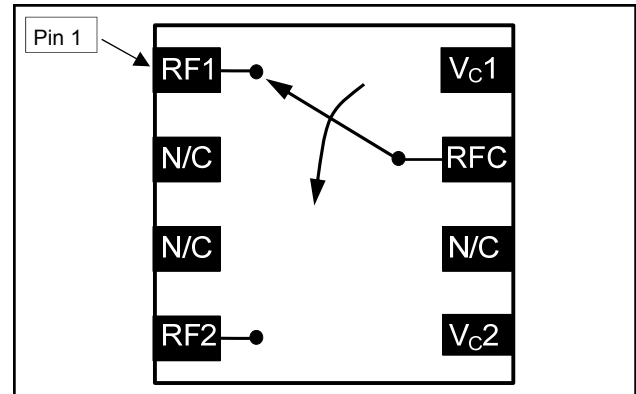

### Pin Configuration <sup>4</sup>

Pin No.	Pin Name	Description
1	RF1	RF Output 1
2	N/C	No Connection
3	N/C	No Connection
4	RF2	RF Output 2
5	V <sub>c2</sub>	Voltage Control 2
6	N/C	No Connection
7	RFC	RF Common
8	V <sub>c1</sub>	Voltage Control 1
9	Paddle <sup>5</sup>	RF and DC Ground

4. M/A-COM recommends connecting unused package pins to ground.
5. The exposed pad centered on the package bottom must be connected to RF and DC ground.

### Absolute Maximum Ratings <sup>6,7</sup>

Parameter	Absolute Maximum
Input Power @ 3 V Control	+32 dBm
Input Power @ 5 V Control	+34 dBm
Operating Voltage	+8.5 volts
Operating Temperature	-40°C to +85°C
Storage Temperature	-65°C to +150°C

6. Exceeding any one or combination of these limits may cause permanent damage to this device.
7. M/A-COM does not recommend sustained operation near these survivability limits.

\* Restrictions on Hazardous Substances, European Union Directive 2002/95/EC.

**ADVANCED:** Data Sheets contain information regarding a product M/A-COM Technology Solutions is considering for development. Performance is based on target specifications, simulated results, and/or prototype measurements. Commitment to develop is not guaranteed.  
**PRELIMINARY:** Data Sheets contain information regarding a product M/A-COM Technology Solutions has under development. Performance is based on engineering tests. Specifications are typical. Mechanical outline has been fixed. Engineering samples and/or test data may be available. Commitment to produce in volume is not guaranteed.

• **North America** Tel: 800.366.2266 / Fax: 978.366.2266  
 • **Europe** Tel: 44.1908.574.200 / Fax: 44.1908.574.300  
 • **Asia/Pacific** Tel: 81.44.844.8296 / Fax: 81.44.844.8298  
 Visit [www.macomtech.com](http://www.macomtech.com) for additional data sheets and product information.

M/A-COM Technology Solutions Inc. and its affiliates reserve the right to make changes to the product(s) or information contained herein without notice.

## GaAs Broadband SPDT Switch DC - 8.0 GHz

Rev. V5

### Electrical Specifications: $T_A = 25^\circ\text{C}$ , $Z_0 = 50 \Omega$ , $V_C = 0 \text{ V} / 3 \text{ V}$ , 8 pF Capacitor <sup>8,9</sup>

Parameter	Test Conditions	Units	Min.	Typ.	Max.
Insertion Loss <sup>10</sup>	2.0 - 6.0 GHz	dB	—	0.50	0.8
	6.0 - 8.0 GHz	dB	—	0.75	—
Isolation	2.4 GHz	dB	24	29	—
	5.3 GHz	dB	28	33	—
	5.8 GHz	dB	25	30	—
	6.0 - 8.0 GHz	dB	—	20	—
Return Loss	DC - 8.0 GHz	dB	—	16	—
Input IP2	Two Tone, +5 dBm / Tone, 5 MHz Spacing				
	2.4 GHz	dBm	—	92	—
	5.3 GHz	dBm	—	83	—
	5.8 GHz	dBm	—	85	—
Input IP3	Two Tone, +5 dBm / Tone, 10 MHz Spacing				
	2.4 GHz (3V)	dBm	—	54	—
	5.8 GHz (3V)	dBm	—	49	—
	2.4 GHz (5V)	dBm	—	55	—
	5.8 GHz (5V)	dBm	—	51	—
	Two Tone, +15 dBm / Tone, 10 MHz Spacing				
	2.4 GHz (3V)	dBm	—	57	—
	5.8 GHz (3V)	dBm	—	54	—
2.4 GHz (5V)	dBm	—	59	—	
5.8 GHz (5V)	dBm	—	58	—	
Input P0.1dB	2.4 GHz	dBm	—	26	—
	5.3 GHz	dBm	—	26	—
	5.8 GHz	dBm	—	25	—
Input P1dB	2.4 GHz	dBm	—	30.5	—
	5.3 GHz	dBm	—	29.5	—
	5.8 GHz	dBm	—	27	—
Linear Pout	2.4 GHz, OFDM, QAM-64, 54 Mbps, EVM = 2.5%				
	3 V	dBm	—	21	—
	5 V	dBm	—	27.5	—
8 V	dBm	—	30	—	
2nd Harmonic	2.4 GHz, PIN = +20 dBm	dBc	—	-80	—
	5.3 GHz, PIN = +20 dBm	dBc	—	-71	—
	5.8 GHz, PIN = +20 dBm	dBc	—	-71	—
3rd Harmonic	2.4 GHz, PIN = +20 dBm	dBc	—	-83	—
	5.3 GHz, PIN = +20 dBm	dBc	—	-71	—
	5.8 GHz, PIN = +20 dBm	dBc	—	-72	—
T-rise, T-fall	10% to 90% RF and 90% to 10% RF	ns	—	13	—
Ton, Toff	50% control to 90% RF and 50% control to 10% RF	ns	—	35	—
Transients		mV	—	14	—
Control Current	VC  = 3 V	μA	—	1	5
RON	t > 90 ms after OFF to ON Switching (settled)	Ω	—	2.50	—
Gate Lag	ΔRon  between 15 μs and 90 ms after OFF to ON Switching	Ω	—	0.15	—

8. For positive voltage control, external DC blocking capacitors are required on all RF ports.

9. Electrical minimum and maximum specifications are guaranteed in final package assembly only.

10. Insertion loss can be optimized by varying the DC blocking capacitor value.

2

**ADVANCED:** Data Sheets contain information regarding a product M/A-COM Technology Solutions is considering for development. Performance is based on target specifications, simulated results, and/or prototype measurements. Commitment to develop is not guaranteed.

**PRELIMINARY:** Data Sheets contain information regarding a product M/A-COM Technology Solutions has under development. Performance is based on engineering tests. Specifications are typical. Mechanical outline has been fixed. Engineering samples and/or test data may be available. Commitment to produce in volume is not guaranteed.

• **North America** Tel: 800.366.2266 / Fax: 978.366.2266

• **Europe** Tel: 44.1908.574.200 / Fax: 44.1908.574.300

• **Asia/Pacific** Tel: 81.44.844.8296 / Fax: 81.44.844.8298

Visit [www.macomtech.com](http://www.macomtech.com) for additional data sheets and product information.

M/A-COM Technology Solutions Inc. and its affiliates reserve the right to make changes to the product(s) or information contained herein without notice.

### Die Outline Drawing <sup>11,12,13,14</sup>

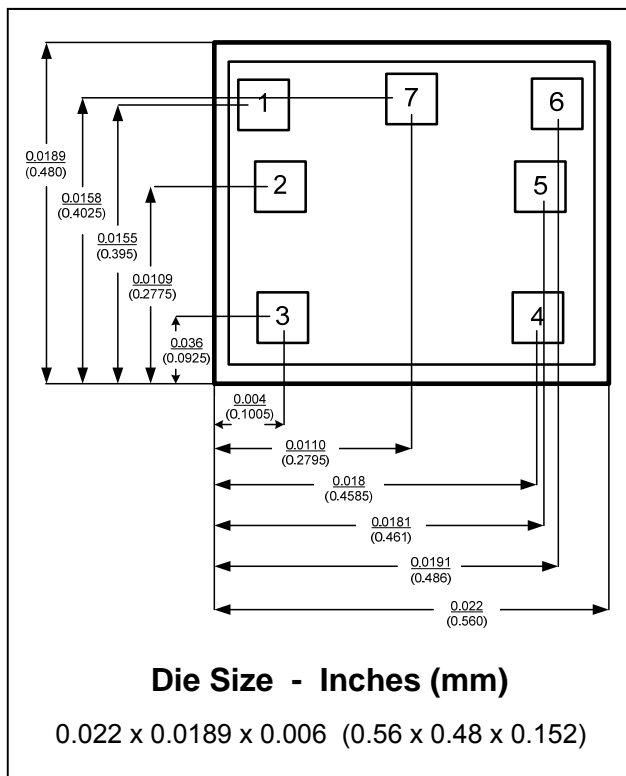

11. Typical dimensions in inches (millimeters)
12. Die thickness is 0.006" (0.152 mm)
13. Typical bond pad is 0.003" square (0.076 mm square)
14. Bond pad metallization is gold.

### Qualification

Qualified to M/A-COM specification REL-201, Process Flow -2.

### Handling Procedures

Please observe the following precautions to avoid damage:

### Static Sensitivity

Gallium Arsenide Integrated Circuits are sensitive to electrostatic discharge (ESD) and can be damaged by static electricity. Proper ESD control techniques should be used when handling these devices.

### Die Bond Pad Configuration

Pad No.	Name	Description
1	V <sub>c1</sub>	Voltage Control 1
2	RF1	RF Output 1
3	GND	Ground
4	GND	Ground
5	RF2	RF Output 2
6	V <sub>c2</sub>	Voltage Control 2
7	RFC	RF Common

### Application Schematic

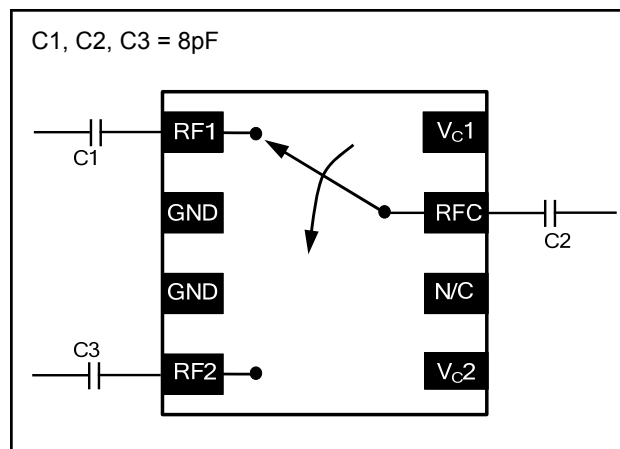

### Truth Table <sup>15</sup>

Control V <sub>c1</sub>	Control V <sub>c2</sub>	RFC—RF1	RFC—RF2
1	0	On	Off
0	1	Off	On

15. 1 = +2.9 V to +5 V, 0 = 0 V ± 0.2 V.

### Typical Performance Curves

**Return Loss vs. Frequency**

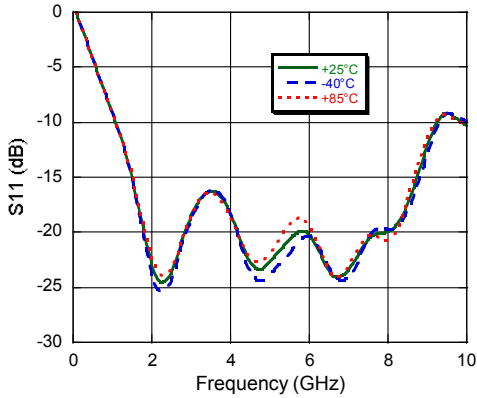

**Isolation vs. Frequency**

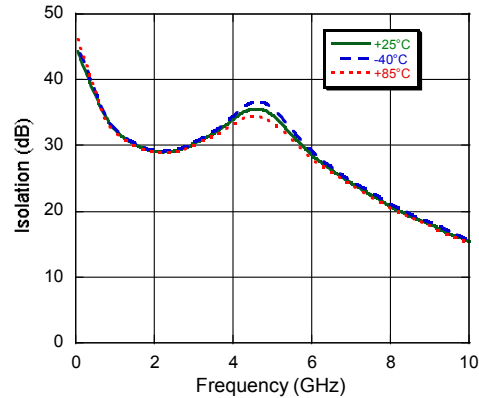

**Insertion Loss vs. Frequency**

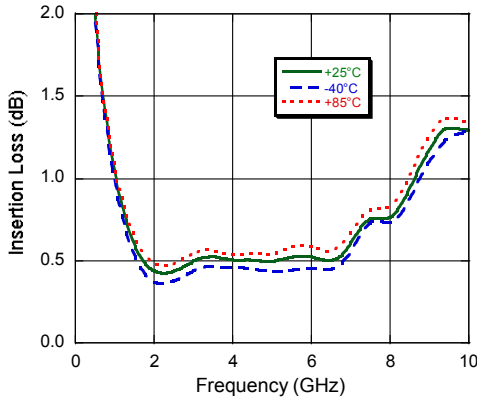

**EVM vs. Pout @ 2.4 GHz**

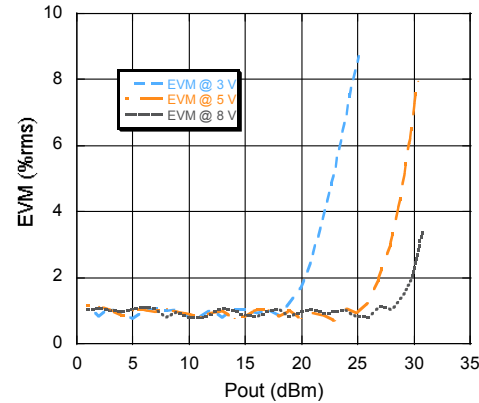

### Lead Free 2 mm 8-lead PDFN †

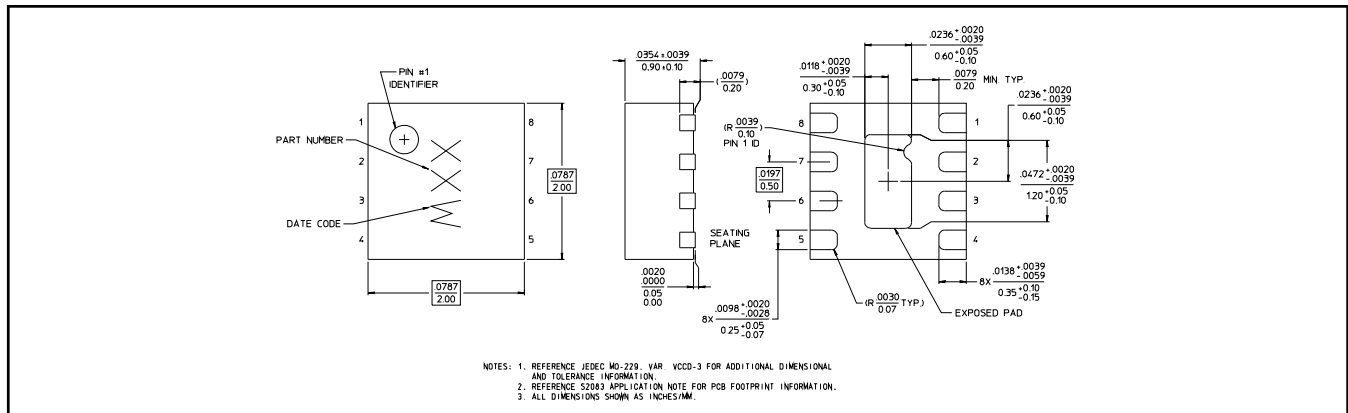

† Reference Application Note M538 for lead-free solder reflow recommendations. Meets JEDEC moisture sensitivity level 1 requirements.

**ADVANCED:** Data Sheets contain information regarding a product M/A-COM Technology Solutions is considering for development. Performance is based on target specifications, simulated results, and/or prototype measurements. Commitment to develop is not guaranteed.  
**PRELIMINARY:** Data Sheets contain information regarding a product M/A-COM Technology Solutions has under development. Performance is based on engineering tests. Specifications are typical. Mechanical outline has been fixed. Engineering samples and/or test data may be available. Commitment to produce in volume is not guaranteed.

- **North America** Tel: 800.366.2266 / Fax: 978.366.2266
- **Europe** Tel: 44.1908.574.200 / Fax: 44.1908.574.300
- **Asia/Pacific** Tel: 81.44.844.8296 / Fax: 81.44.844.8298

Visit [www.macomtech.com](http://www.macomtech.com) for additional data sheets and product information.

M/A-COM Technology Solutions Inc. and its affiliates reserve the right to make changes to the product(s) or information contained herein without notice.



Компания «ЭлектроПласт» предлагает заключение долгосрочных отношений при поставках импортных электронных компонентов на взаимовыгодных условиях!

Наши преимущества:

- Оперативные поставки широкого спектра электронных компонентов отечественного и импортного производства напрямую от производителей и с крупнейших мировых складов;
- Поставка более 17-ти миллионов наименований электронных компонентов;
- Поставка сложных, дефицитных, либо снятых с производства позиций;
- Оперативные сроки поставки под заказ (от 5 рабочих дней);
- Экспресс доставка в любую точку России;
- Техническая поддержка проекта, помощь в подборе аналогов, поставка прототипов;
- Система менеджмента качества сертифицирована по Международному стандарту ISO 9001;
- Лицензия ФСБ на осуществление работ с использованием сведений, составляющих государственную тайну;
- Поставка специализированных компонентов (Xilinx, Altera, Analog Devices, Intersil, Interpoint, Microsemi, Aeroflex, Peregrine, Syfer, Eurofarad, Texas Instrument, Miteq, Cobham, E2V, MA-COM, Hittite, Mini-Circuits, General Dynamics и др.);

Помимо этого, одним из направлений компании «ЭлектроПласт» является направление «Источники питания». Мы предлагаем Вам помощь Конструкторского отдела:

- Подбор оптимального решения, техническое обоснование при выборе компонента;
- Подбор аналогов;
- Консультации по применению компонента;
- Поставка образцов и прототипов;
- Техническая поддержка проекта;
- Защита от снятия компонента с производства.



#### Как с нами связаться

**Телефон:** 8 (812) 309 58 32 (многоканальный)

**Факс:** 8 (812) 320-02-42

**Электронная почта:** [org@eplast1.ru](mailto:org@eplast1.ru)

**Адрес:** 198099, г. Санкт-Петербург, ул. Калинина, дом 2, корпус 4, литера А.