

Single Tine PTH 18-24 AWG: WTB

9176-600

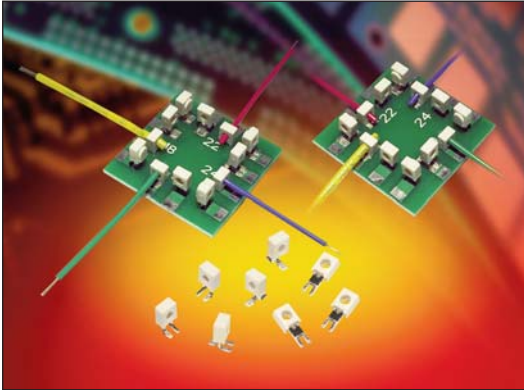

The market and applications for simple and reliable discrete Wire-to-Board (WTB) connectors continue to evolve. Developed for harsh industrial and automotive applications, Insulation Displacement Connectors (IDC) have been used in hundreds of applications connecting wires to PCB's from transportation wiring to every day LED lighting and smart meter/sensor connections. Size, performance and simplicity have been the key factors for selecting this connector when long term reliability is critical.

This single contact version of the proven 9176 family of connectors is the first in Plated Through Hole (PTH) termination. While supporting all of the features and benefits from the SMT offering, this connector provides a new option for a small, cost effective and high performance WTB solution.

APPLICATIONS

- Machine Controls: motors, drives, solenoids, sensors, fans and pumps
- Commercial Buildings: controls, security, fire and sensors
- Smart Grid: meters, breakers and panels
- SSL/LED: bulbs, fixtures, signage and streetlights
- Application notes: reference 201-01-142

FEATURES AND BENEFITS

- IDC contact provides a gas-tight connection to the PCB for long term reliability
- Plastic cap retains the contact and then acts as the assembly tool to terminate the wires; no special tooling.
- Tested to automotive levels on shock, vibration and temperature cycling for reliability
- The IDC contact reduces the total applied cost versus solder or crimp processes
- Connectors are available in two configurations for maximum flexibility: End and Through Wire

ELECTRICAL

- Current Rating: See matrix below
- Voltage Rating: 600 VAC

ENVIRONMENTAL

- Operating Temperature: -40°C to +125°C

MECHANICAL

- Contact Material: Phosphor Bronze
- Contact Plating: Tin over Nickel
- Durability: 3 Cycles

HOW TO ORDER

00 **9176** **001**
Prefix Series Number of Ways
001 = 1

60X
Contact Style

9
Color Option
White Standard

X
Cap Options

6
Plating Option
Tin Plated

| Code | Description | Accepted Wire Gauge | Wire Gauges |
|------|---------------------------------------|---------------------------|-------------|
| 600 | Capped IDC Connector PTH PCB Mount | 18 AWG Stranded | ø1.6-2.1 |
| 601 | | 20 AWG Solid and Stranded | ø1.6-2.1 |
| 602 | | 22 AWG Solid and Stranded | ø1.1-1.6 |
| 603 | | 24 AWG Solid and Stranded | ø1.1-1.6 |

| Code | Cap Option | Description | Details |
|------|--------------|--|------------|
| 0 | Through Wire | Allows wire to be terminated at any point | See page 2 |
| 9 | Wire Stop | Terminates end of wire End protected by stop face | See page 3 |

CURRENT RATING

| 18AWG | 20AWG | 22AWG | 24AWG |
|-------|-------|-------|-------|
| 9A | 8A | 6A | 5A |



Single Tine PTH 18-24 AWG: WTB

9176-600

18-24 AWG 1 WAY PTH CONNECTOR THROUGH WIRE CAPPED

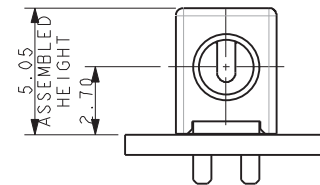
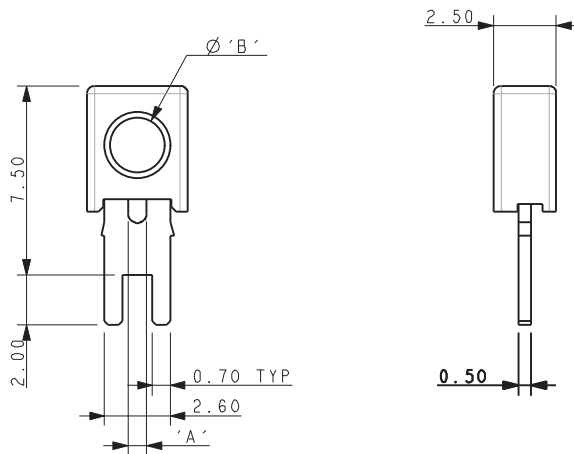
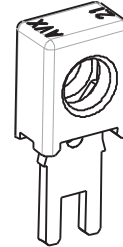
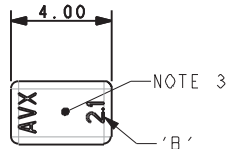

| Code | Accepted Wire Gauge | A | Wire Insulation | B |
|------|--------------------------|------|-----------------|-----|
| 600 | 18 AWG Stranded | 0.74 | Ø 1.6-2.1 | 2.1 |
| 601 | 20 AWG Solid or Stranded | 0.60 | Ø 1.6-2.1 | 2.1 |
| 602 | 22 AWG Solid or Stranded | 0.47 | Ø 1.1-1.6 | 1.6 |
| 603 | 24 AWG Solid or Stranded | 0.37 | Ø 1.1-1.6 | 1.6 |



PACKING DETAILS

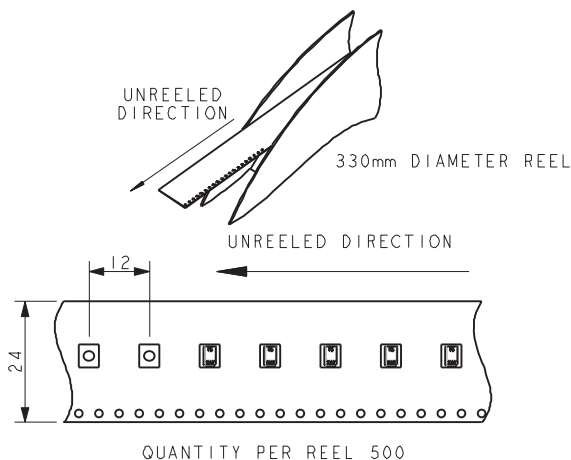

SUGGESTED PCB LAYOUT

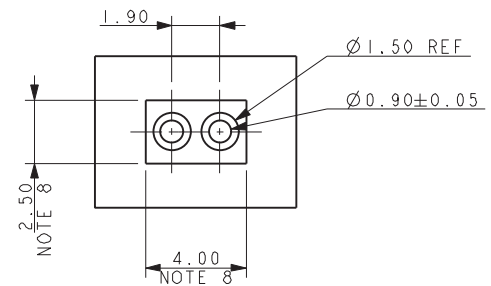

NOTES:

- 1 WAY CONNECTOR FOR PTH WIRE TO BOARD CONNECTION, PRE-ASSEMBLED THROUGH WIRE CAP, CODE SEE PAGE 1.
- CONTACT/CAP TO MATCH 20AWG-24AWG SOLID AND STRANDED WIRES, 18AWG WILL ONLY ACCEPT STRANDED WIRES, SEE TABLE.
- FLAT FACE ON TOP OF CAP TO AID PICK AND PLACE ASSEMBLY, MAXIMUM DIAMETER 1.8MM.
- FOR FULL PRODUCT SPECIFICATION ON STANDARD CONNECTORS REFER TO ELCO SPEC 201-01-163.
- ASSEMBLY PROCEDURE, REFER TO APPLICATION NOTES 201-01-142.
- GENERAL TOLERANCE ± 0.20 UNLESS STATED.
- PACKED IN TAPE AND REEL, QUANTITY PER REEL 500.
- CONNECTOR OUTLINE.
- CONTACT MATERIAL: TIN PLATED COPPER ALLOY.
- INSULATION MATERIAL: HIGH TEMPERATURE NYLON, GLASS FILLED, UL94 V-O. COLOR REFER TO PAGE 1.

Single Tine PTH 18-24 AWG: WTB

9176-600

18-24 AWG 1 WAY PTH CONNECTOR WIRE STOP CAPPED

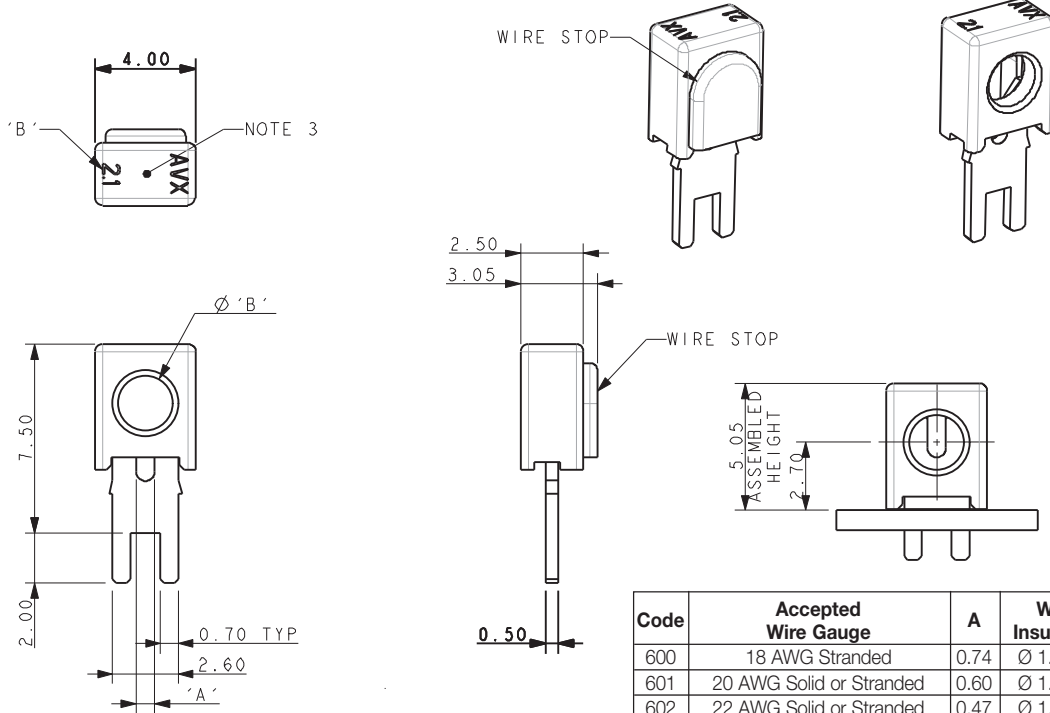

| Code | Accepted Wire Gauge | A | Wire Insulation | B |
|------|--------------------------|------|-----------------|-----|
| 600 | 18 AWG Stranded | 0.74 | Ø 1.6-2.1 | 2.1 |
| 601 | 20 AWG Solid or Stranded | 0.60 | Ø 1.6-2.1 | 2.1 |
| 602 | 22 AWG Solid or Stranded | 0.47 | Ø 1.1-1.6 | 1.6 |
| 603 | 24 AWG Solid or Stranded | 0.37 | Ø 1.1-1.6 | 1.6 |

SUGGESTED PCB LAYOUT

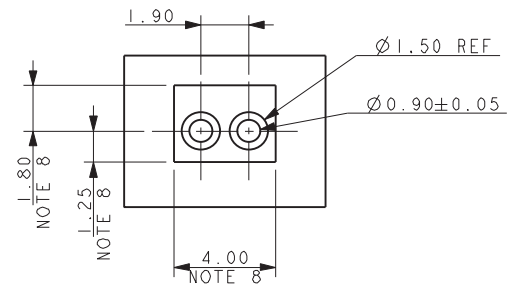

PACKING DETAILS

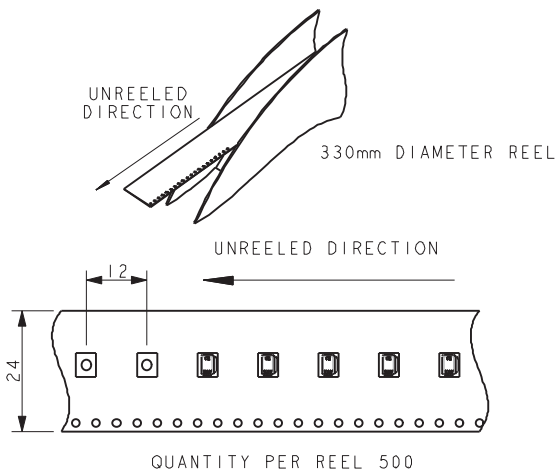

NOTES:

- 1 WAY CONNECTOR FOR PTH WIRE TO BOARD CONNECTION, PRE-ASSEMBLED WIRE STOP CAP, CODE SEE PAGE 1.
- CONTACT/CAP TO MATCH 20AWG-24AWG SOLID AND STRANDED WIRES, 18AWG WILL ONLY ACCEPT STRANDED WIRES, SEE TABLE.
- FLAT FACE ON TOP OF CAP TO AID PICK AND PLACE ASSEMBLY, MAXIMUM DIAMETER 1.8MM.
- FOR FULL PRODUCT SPECIFICATION ON STANDARD CONNECTORS REFER TO ELCO SPEC 201-01-163.
- ASSEMBLY PROCEDURE, REFER TO APPLICATION NOTES 201-01-142.
- GENERAL TOLERANCE ± 0.20 UNLESS STATED.
- PACKED IN TAPE AND REEL, QUANTITY PER REEL 500.
- CONNECTOR OUTLINE.
- CONTACT MATERIAL: TIN PLATED COPPER ALLOY.
- INSULATION MATERIAL: HIGH TEMPERATURE NYLON, GLASS FILLED, UL94 V-O. COLOR REFER TO PAGE 1.
- WIRE STOP CAP PROTECTS END OF WIRE.

Single Tine PTH 18-24 AWG: WTB

9176-600

18-24 AWG ASSEMBLED CAPPE PTH CONNECTORS

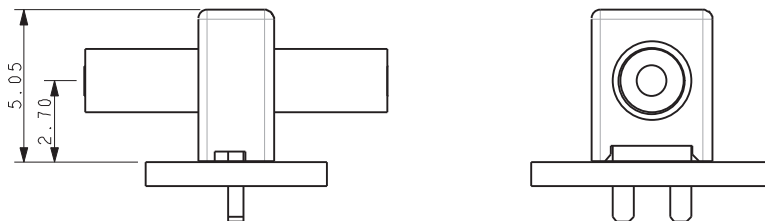

NOMINAL ASSEMBLED HEIGHTS

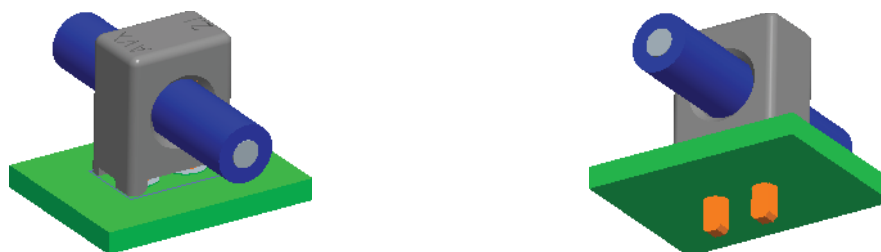

TYPICAL THROUGH WIRE ASSEMBLIES



TYPICAL WIRE STOP ASSEMBLIES



Компания «ЭлектроПласт» предлагает заключение долгосрочных отношений при поставках импортных электронных компонентов на взаимовыгодных условиях!

Наши преимущества:

- Оперативные поставки широкого спектра электронных компонентов отечественного и импортного производства напрямую от производителей и с крупнейших мировых складов;
- Поставка более 17-ти миллионов наименований электронных компонентов;
- Поставка сложных, дефицитных, либо снятых с производства позиций;
- Оперативные сроки поставки под заказ (от 5 рабочих дней);
- Экспресс доставка в любую точку России;
- Техническая поддержка проекта, помощь в подборе аналогов, поставка прототипов;
- Система менеджмента качества сертифицирована по Международному стандарту ISO 9001;
- Лицензия ФСБ на осуществление работ с использованием сведений, составляющих государственную тайну;
- Поставка специализированных компонентов (Xilinx, Altera, Analog Devices, Intersil, Interpoint, Microsemi, Aeroflex, Peregrine, Syfer, Eurofarad, Texas Instrument, Miteq, Cobham, E2V, MA-COM, Hittite, Mini-Circuits, General Dynamics и др.);

Помимо этого, одним из направлений компании «ЭлектроПласт» является направление «Источники питания». Мы предлагаем Вам помощь Конструкторского отдела:

- Подбор оптимального решения, техническое обоснование при выборе компонента;
- Подбор аналогов;
- Консультации по применению компонента;
- Поставка образцов и прототипов;
- Техническая поддержка проекта;
- Защита от снятия компонента с производства.



Как с нами связаться

Телефон: 8 (812) 309 58 32 (многоканальный)

Факс: 8 (812) 320-02-42

Электронная почта: org@eplast1.ru

Адрес: 198099, г. Санкт-Петербург, ул. Калинина, дом 2, корпус 4, литера А.