

Description

The AVQ100-24S05 is a single output DC-DC converter with standard quarter-brick outline and pin configuration. It delivers up to 20A output current with 5V output voltage. Above 93% ultra-high efficiency and excellent thermal performance makes it an ideal choice in telecom and datacom application.

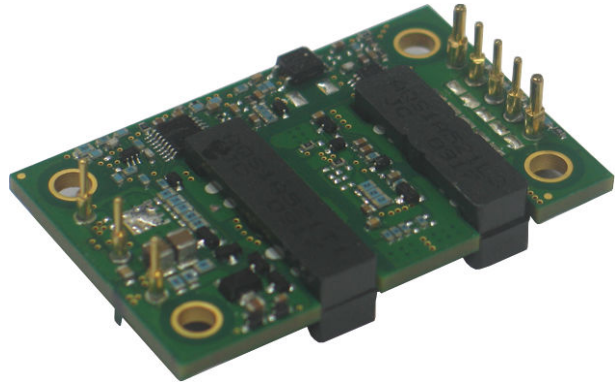

Operational Features

- Delivers up to 20A output current
- Ultra-high efficiency 93% typ. at half load
- Wide input range: 18V ~36V
- Basic isolation
- Low output noise
- Excellent thermal performance
- No minimum load requirement
- Zero output capacitance
- RoHS 6 compliant

Control Features

- Remote control function (negative or positive logic optional)
- Remote output sense
- Trim function: 80% ~ 110%

Protection Features

- Input under voltage lockout
- Output over current protection
- Output over voltage protection
- Over temperature protection

Mechanical Features

- Industry standard quarter-brick pin-out outline
- Open frame
- Pin length option: 4.8mm

Safety & EMC

- Meets safety standards UL 60950-1, CSA-C22.2 NO. 60950-1, IEC/EN 60950-1 and GB4943.
- Approved by UL and TUV.
- Meets 2006/95/EEC and 93/68/EEC directives which facilitates CE marking in user's end product
- Meets conducted emission's requirements of FCC Class A and EN55022 Class A with external filter.

Electrical Characteristics

Full operating ambient temperature range is -40°C to +85°C.

Specifications are subject to change without notice.

Parameter		Min.	Typ.	Max.	Unit	Notes & Conditions
Absolute max. ratings						
Input voltage	Non-operating	0		50	V	100ms
	Operating	0		40	V	Continuous
Operating temperature		-40		85	°C	
Storage temperature		-55		125	°C	
Voltage at remote ON/OFF pin		-0.7		12	V	
Input characteristics						
Operating input voltage range		18	24	36	V	
Input under-voltage lockout	Turn-on voltage threshold	15	17	18	V	
	Turn-off voltage threshold	14	16	17	V	
	Lockout voltage hysteresis	1		3	V	
Max. input current				6.3	A	V _{in} =0-V _{inmax} I _{out} =I _{omax}
No-load input current				0.2	A	
Standby Input current			0.01	0.1	A	Remote OFF
Inrush current transient rating			0.2	1	A ² s	Figure 14
Input reflected ripple current			20	50	mA	Figure 3 Through 12μH inductor; Figure 14
Recommended input fuse				15	A	Fast blow external fuse recommended; Figure 10
Input filter component values (C/L)			6.6\2.2		μF\μH	Internal values
Recommended external input capacitance			220		μF	Low ESR capacitor recommended; Figure 10
Output characteristics						
Output voltage set point (standard option)		4.95	5	5.05	V	48V _{in} , full load
Output voltage line regulation			0.2		%	
			1		mV	

Parameter		Min.	Typ.	Max.	Unit	Notes & Conditions
Output voltage load regulation			0.2		%	
			1		mV	
Output voltage temperature regulation			0.02		%/°C	
Total output voltage range		4.85	5	5.15	V	Over sample, line, load, temperature & life
Output voltage ripple and noise			20	140	mVpp	Figure 2 20MHz bandwidth; Figure 14
Operating output current range		0		20	A	
Output DC current-limit inception		22		28	A	Hiccup: auto-restart when over-current condition is removed
Output capacitance		0	470	5000	μF	High frequency and low ESR is recommended
Dynamic characteristics						
Dynamic response	50% ~ 75% ~ 50% $I_{o,max}$, 0.1A/μs		85		mV	Figure 4 Test condition: 25°C, nominal input voltage, see Figure 10
	Settling time		50		μs	Recovery to within 1% $V_{o,nom}$
	50% ~ 75% ~ 50% $I_{o,max}$, 1A/μs		95		mV	Figure 5 Test condition: 25°C, nominal input voltage, see Figure 10
	Settling time		80		μs	Recovery to within 1% $V_{o,nom}$
Turn-on transient	Rise time		8	30	ms	Full load, Figure 6
	Turn-on delay time		4	30	ms	Figure 6
	Output voltage overshoot		0		% V_o	Figure 6
Efficiency						
100% load			92.5		%	Figure 1
50% load			93		%	Figure 1

Electrical Characteristics (Continued)

Parameter	Min.	Typ.	Max.	Unit	Notes & Conditions	
Isolation characteristics						
Isolation voltage (conditions: 1mA for 60s, slew rate of 1500V/10s)	1500			V	Basic insulation, pollution degree 2, input to output	
Feature characteristics						
Switching frequency		310		kHz		
Remote ON/OFF control (positive logic)	Off-state voltage	-0.7		1.2	V	See Figure 11
	On-state voltage	3.5		12	V	
Remote ON/OFF control (negative logic)	Off-state voltage	3.5		12	V	
	On-state voltage	-0.7		1.2	V	
Output voltage trim range	4		5.5	V	See <i>Trim Characteristics</i> of <i>Application Note</i>	
Output voltage remote sense range			0.25	V		
Output over-voltage protection	120	130	150	%Vo,nom	Hiccup: auto-restart when over-voltage condition is removed	
Over-temperature shutdown		125		°C	Auto recovery; over-temperature protect(OTP) test point: see Figure 16	
Over-temperature hysteresis	5	10		°C		
Reliability characteristics						
Calculated MTBF (telcordia)		2.5		10 ⁶ h	Telcordia SR-332-2006; 80% load, 300LFM, 40°C T _a	

Electromagnetic compatibility requirements

Test Item	Regulations	Criteria	Notes & Conditions
Conducted Emission	EN 55022 DC input port, Class A/B Limits	A	See EMC test conditions
Immunity to Electrostatic Discharge	IEC/EN61000-4-2 Enclosure Port, Level 3	B	
Immunity to Electrical Fast Transient	IEC/EN61000-4-4 DC input port, Level 3	B	
Immunity to Surges	IEC/EN61000-4-5 DC input port Line to Ground(earth): 600V Line to Line: 600V	B	
Immunity to Continuous Conducted Interference	IEC/EN61000-4-6 DC input port, Level 2	A	
Immunity To Voltage Dips and short interruptions and voltage variations	EN 61000-4-29 DC input port	B	

Criterion A: Normal performance during and after test.

Criterion B: For EFT and surges, low-voltage protection or reset is not allowed. Temporary output voltage fluctuation ceases after disturbances ceases, and from which the EUT recovers its normal performance automatically. For Dips and ESD, output voltage fluctuation or reset is allowed during the test, but recovers to its normal performance automatically after the disturbance ceases.

Criterion C: Temporary loss of output, the correction of which requires operator intervention.

Criterion D: Loss of output which is not recoverable, owing to damage to hardware.

Qualification Testing

Parameter	Unit (pcs)	Test condition
Halt test	4 ~ 5	$T_{a,min} - 10^{\circ}\text{C}$ to $T_{a,max} + 10^{\circ}\text{C}$, 5°C step, V_{in} = min to max, 0 ~ 105% load
Vibration	3	Frequency range: 5Hz ~ 20Hz, 20Hz ~ 200Hz, A.S.D: $1.0\text{m}^2/\text{s}^3$, -3db/oct, axes of vibration: X/Y/Z Time: 30min/axis
Mechanical shock	3	30g, 6ms, 3axes, 6directions, 3time/direction
Thermal shock	3	-40°C to 100°C , unit temperature 20cycles
Thermal cycling	3	-40°C to 55°C , temperature change rate: $1^{\circ}\text{C}/\text{min}$, cycles: 2cycles
Humidity	3	40°C , 95%RH, 48h
Solder ability	15	IPC J-STD-002C-2007

Characteristic Curves

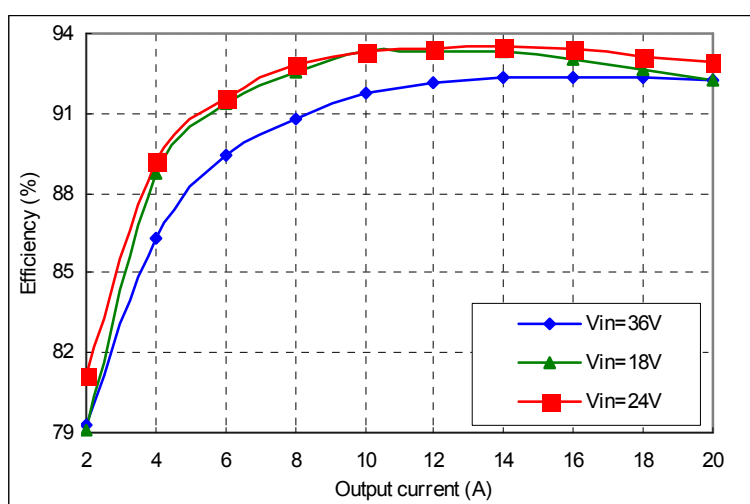

Figure 1 Efficiency vs. output current, $T_a=25^{\circ}\text{C}$, $V_o=5\text{V}$

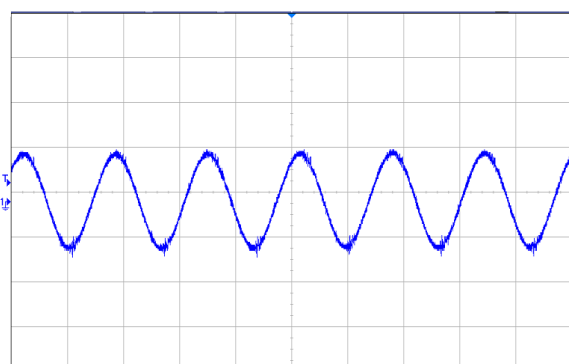

Figure 2 Output ripple & noise (2 $\mu\text{s}/\text{div}$, 5mV/div), see Figure 14 for test configuration

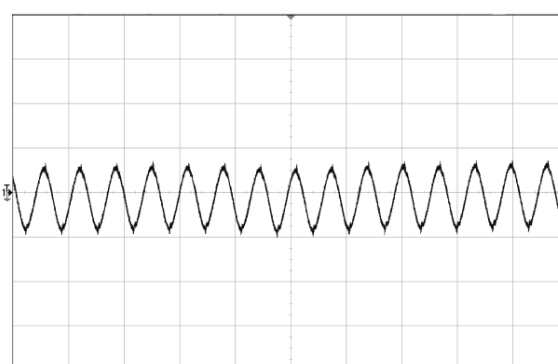

Figure 3 Input reflected ripple current (5 $\mu\text{s}/\text{div}$, 10mA/div), see Figure 14 for test configuration

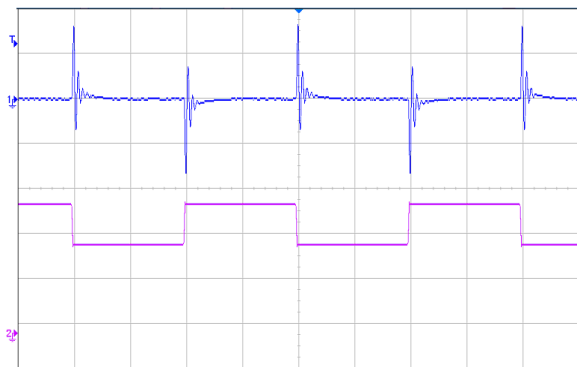

Figure 4 Dynamic response for 25% load step (50% ~ 75% ~ 50%) and 0.1A/μs slew rate, (2ms/div), see Figure 10 for test configuration; CH1-output voltage (50mv/div); CH2- output current (5A/div)

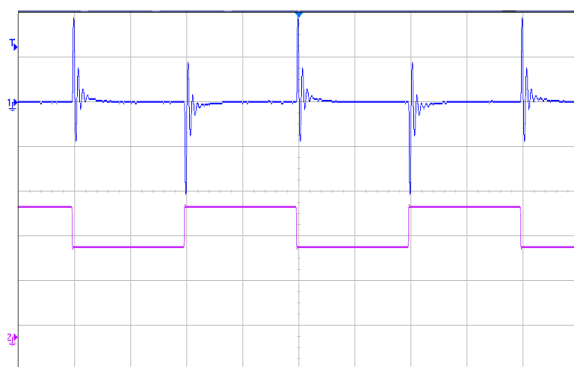

Figure 5 Dynamic response for 25% load step (50% ~ 75% ~ 50%) and 1A/μs slew rate, (2ms/div), see Figure 10 for test configuration; CH1-output voltage (50mv/div); CH2- output current (5A/div)

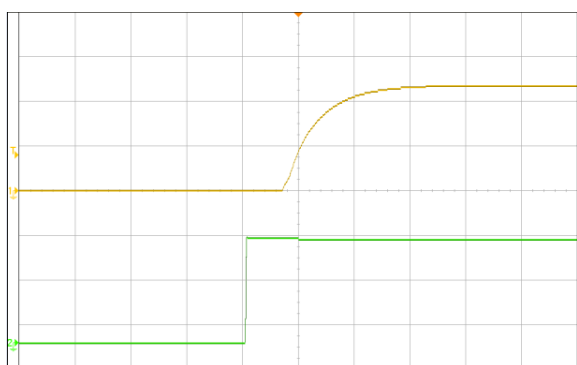

Figure 6 Output voltage startup by power on, (5ms/div), see Figure 10 for test configuration; CH1-output voltage (2V/div); CH2-input voltage (10V/div)

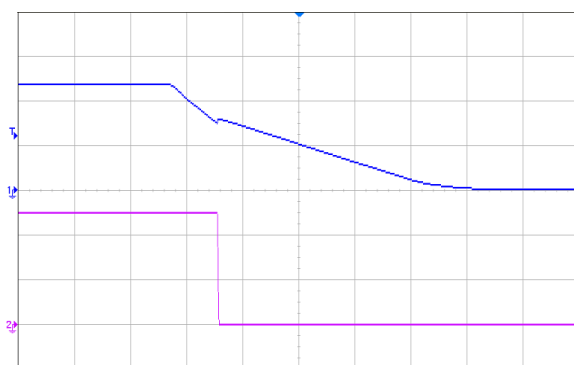

Figure 7 Output voltage shut down by power off, (10ms/div), see Figure 10 for test configuration; CH1-input voltage (10V/div); CH2-output voltage (2V/div)

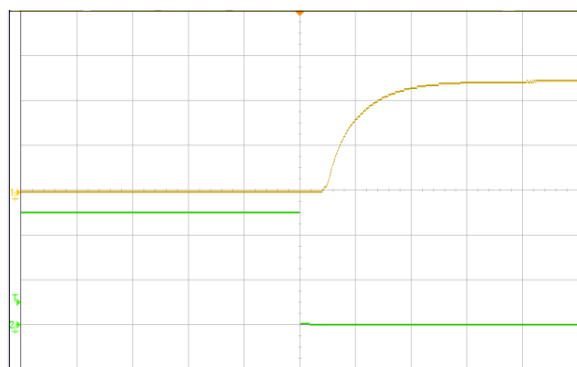

Figure 8 Output voltage startup by remote ON, (5ms/div), see Figure 10 for test configuration; CH1-output voltage (2V/div); CH2-remote ON (2V/div)

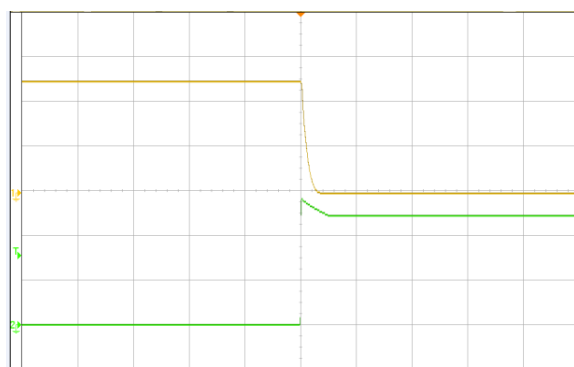

Figure 9 Output voltage shutdown by remote OFF, (500μs/div), see Figure 10 for test configuration; CH1-output voltage (2V/div); CH2-remote OFF voltage (2V/div)

Application Note

Typical Application

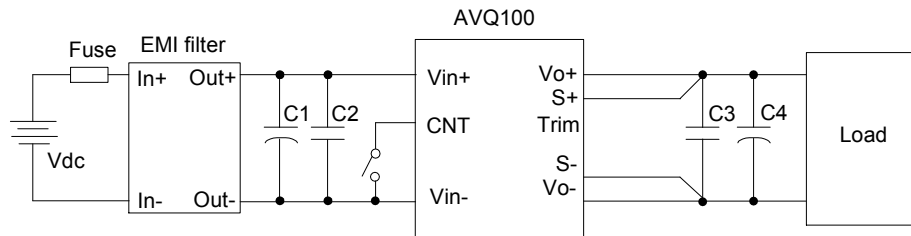

Figure 10 Typical application

C1: 220 μ F/50V electrolytic capacitor, P/N: UPM1H221MPD (Nichicon) or equivalent caps.
 C2, C3: 1 μ F/100V X7R ceramic capacitor, P/N: C3225X7R2A105KT0L0U (TDK) or equivalent caps
 C4: 470 μ F/25V electrolytic capacitor, P/N: UPM1E471MHD (Nichicon) or equivalent caps.
 Note: If ambient temperature is below -5°C, an additional 220 μ F tantalum capacitor (Low ESR, ESR \leq 100m Ω) is needed for output.
 Fuse: External fast blow fuse with a rating of 15A. The recommended fuse model is 216015.P from LITTLEFUSE.

Remote ON/OFF

Either positive or negative remote ON/OFF logic is available in AVQ100-24S05. The logic is CMOS and TTL compatible.

Figure 11 is the detailed internal circuit and reference in AVQ100-24S05.

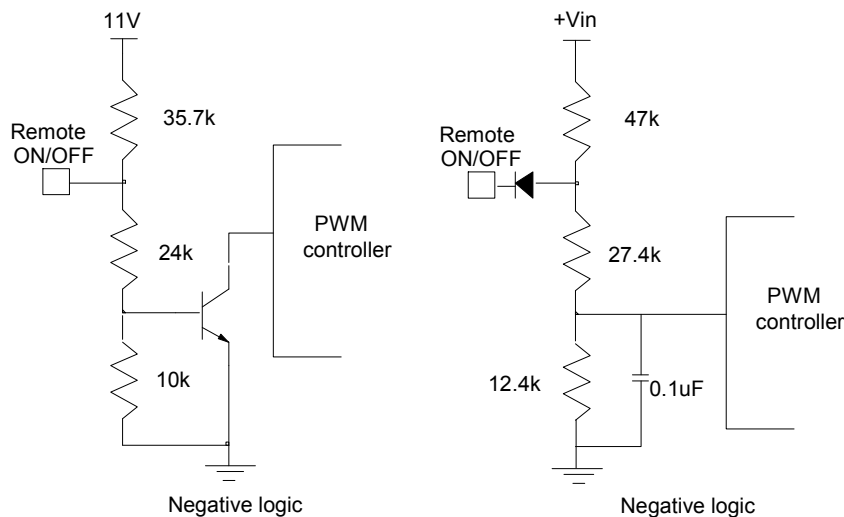

Figure 11 Remote ON/OFF internal diagram

Trim Characteristics

Connecting an external resistor between Trim pin and V_o- pin will decrease the output voltage. While connecting it between Trim and V_o+ will increase the output voltage. The following equations determine the external resistance to obtain the trimmed output voltage.

$$R_{adj_down} = \left(\frac{510}{\Delta} - 10.2 \right) k\Omega$$

$$R_{adj_up} = \left(\frac{5.1 \times V_o (100 + \Delta)}{1.225 \times \Delta} - \frac{510}{\Delta} - 10.2 \right) k\Omega$$

Δ : Output e rate against nominal output voltage.

$$\Delta = \frac{V_{nom} - V_o}{V_{nom}} \times 100$$

V_{norm} : Nominal output voltage.

V_o : Desired output voltage.

For example, to get 5.5V (+110%) output, the trimming resistor is

$$\Delta = \frac{5.5 - 5}{5} \times 100 = 10$$

$$R_{adj_up} = \left(\frac{5.1 \times 5 \times (100 + 10)}{1.225 \times 10} - \frac{510}{10} - 10.2 \right) k\Omega = 167.8 k\Omega$$

The output voltage can also be trimmed by potential applied at the Trim pin.

$$V_o = (V_{trim} + 1.225) \times 2.04$$

Where V_{trim} is the potential applied at the Trim pin, and V_o is the desired output voltage.

When trimming up, the output current should be decreased accordingly so as not to exceed the maximum output power.

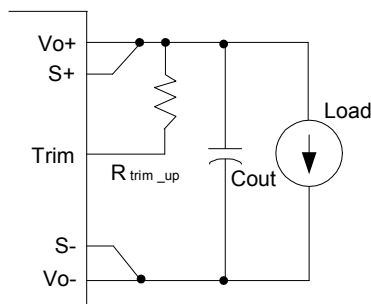

Figure 12 Trim up

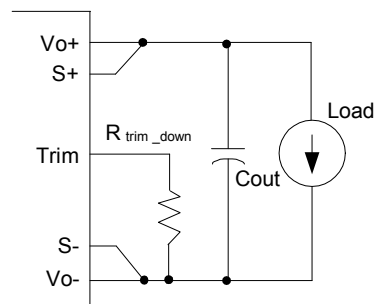

Figure 13 Trim down

Sense Characteristics

If the load is far from the unit, connect S+ and S- to the terminal of the load respectively to compensate the voltage drop on the transmission line. See Figure 10.

If the sense compensate function is not necessary, connect S+ to V_o+ and S- to V_o- directly.

Input Ripple & Inrush Current And Output Ripple & Noise Test Configuration

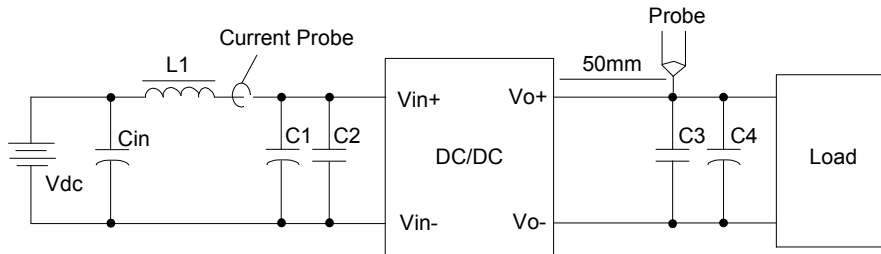

Figure 14 Input ripple & inrush current, ripple & noise test configuration

Vdc: DC power supply

L1: 12μH

Cin: 220μF/100V typical

C1 ~ C4: See Figure 10

Note: Using a coaxial cable with series 50Ω resistor and 0.68μF ceramic capacitor or a ground ring of probe to test output ripple & noise is recommended.

EMC test conditions

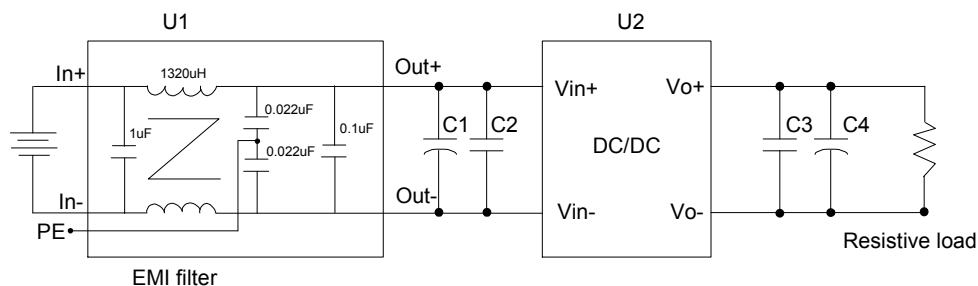

Figure 15 EMC test configuration

U1: Input EMC filter.

U2: Module to test, AVQ100-24S05.

C1 ~ C4: See Figure 10.

Thermal Considerations

The converter is designed to operate in different thermal environments and sufficient cooling must be provided. Proper cooling can be verified by measuring the temperature at test points P1, P2. The temperatures at these points should not exceed the max values in Table 1.

For a typical application, Figure 17 shows the derating of output current vs. ambient air temperature at different air velocity.

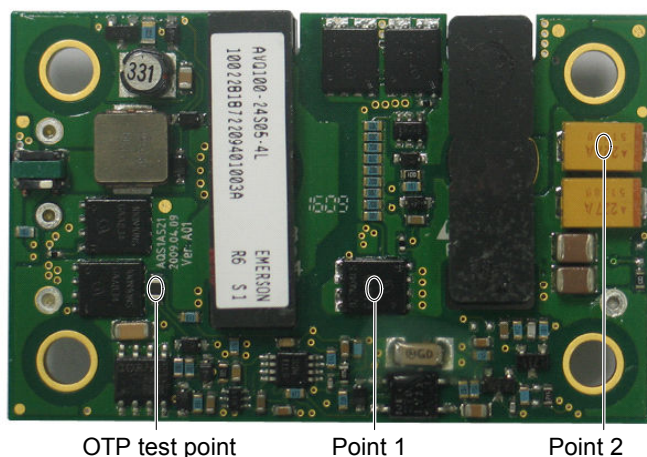

Figure 16 Thermal test points

Table 1 Temperature limits

Test Point	Temperature limit
OTP Test Point	120°C
P1	120°C
P2	110°C

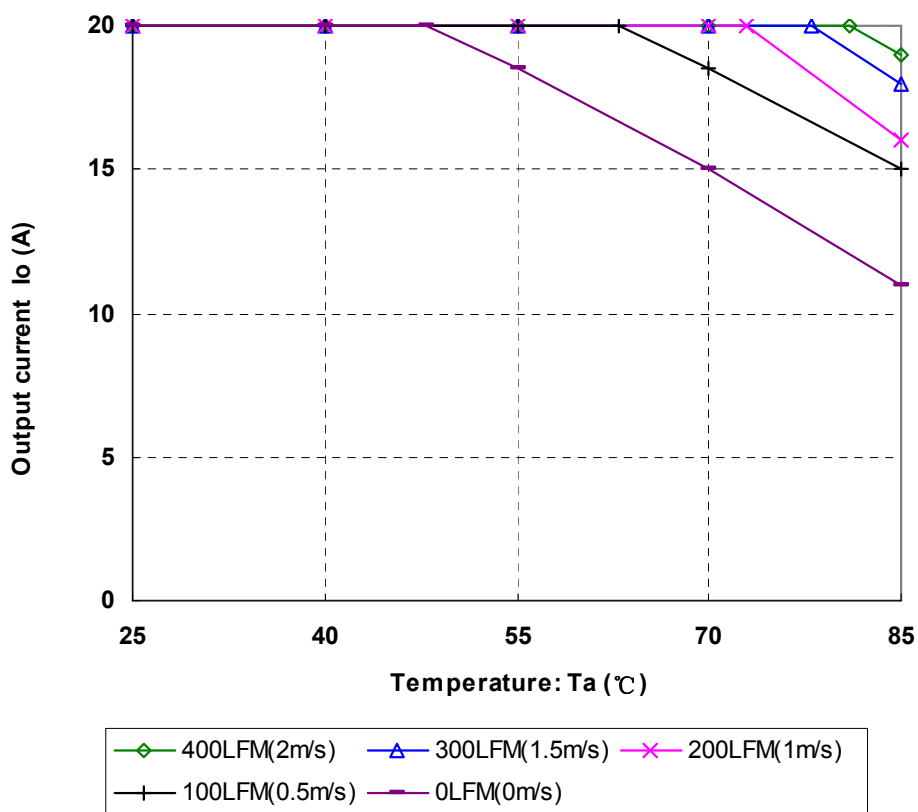

Figure 17 Output power derating, 24V_{in}, air flowing across the converter from pin 3 to pin 1

Thermal image

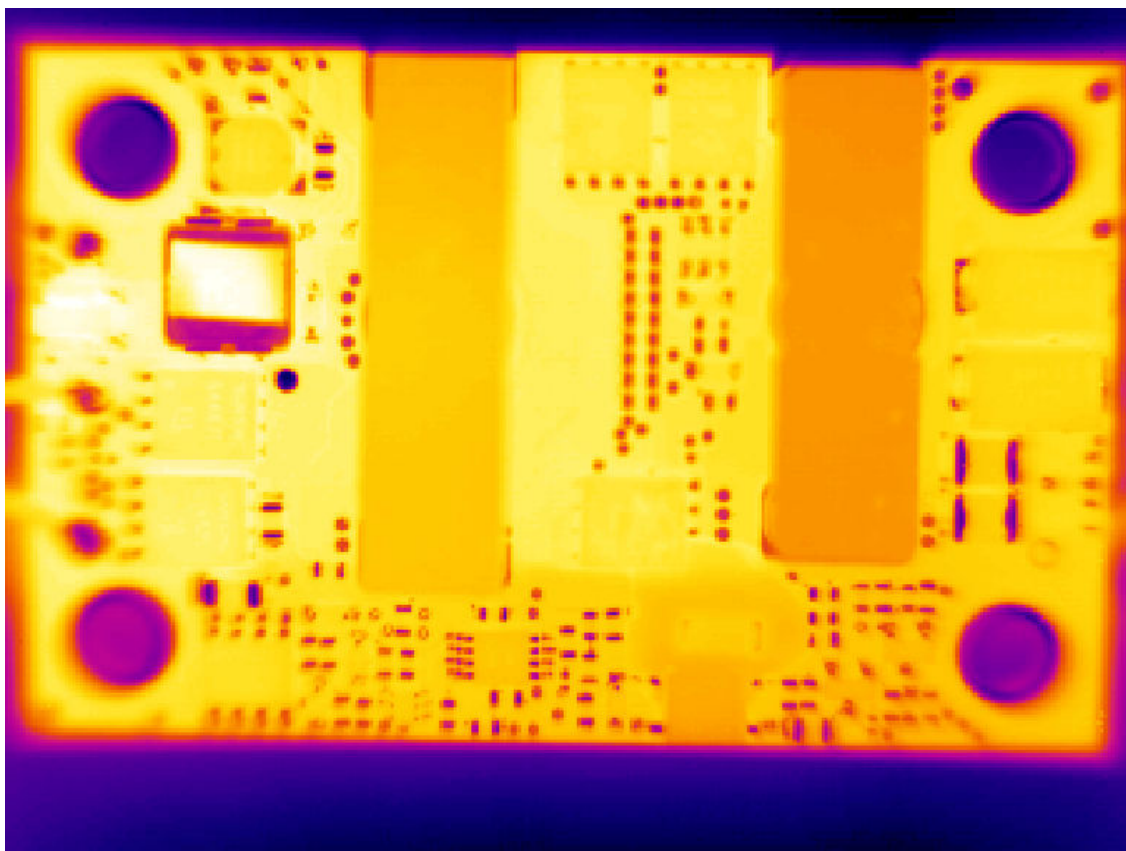
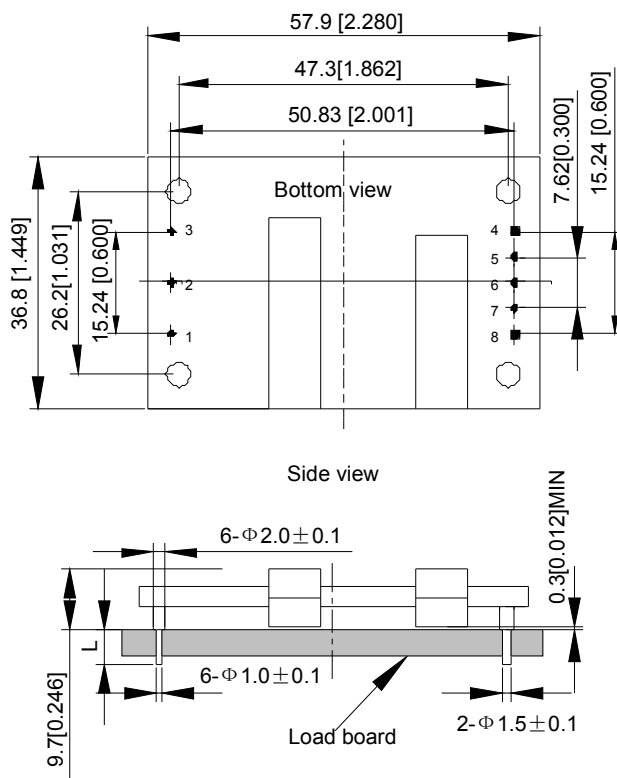

Figure 18 Thermal image, 24V_{in}, 5V_o, full load, room temperature, 200 LFM (air flowing from pin 3 to pin 1)

Mechanical Diagram



Unit: mm[inch] Bottom view: pin on upside

Tolerance: X.Xmm ± 0.5mm [X.X in. ± 0.02in.]

X.XXmm ± 0.25mm [X.XX in. ± 0.01in.]

Figure 19 Mechanical diagram

Pin length option

Device code suffix	L
-4	4.8mm±0.2mm
-6	3.8mm±0.2mm
-8	2.8mm±0.2mm
None	5.8mm±0.2mm

Pin Designations

Pin NO.	Name	Function
1	V _{in+}	Positive input voltage
2	Remote ON/OFF	Remote control
3	V _{in-}	Negative input voltage
4	V _{o-}	Negative output voltage
5	S-	Negative remote sense
6	Trim	Output voltage trim
7	S+	Positive remote sense
8	V _{o+}	Positive output voltage

Soldering

The product is intended for standard manual or wave soldering.

When wave soldering is used, the temperature on pins is specified to maximum 260°C for maximum 7s.

When soldering by hand, the iron temperature should be maintained at 300°C ~ 380°C and applied to the converter pins for less than 10s. Longer exposure can cause internal damage to the converter.

Cleaning of solder joint can be performed with cleaning solvent IPA or similitive.

Ordering Information

AVQ100	-	24	S	05	P	B	-	4	L
①		②	③	④	⑤	⑥		⑦	⑧

①	Model series	AVQ: high efficiency quarter brick series, 100: output power 100W
②	Input voltage	24: 18V ~ 36V input range, rated input voltage 24V
③	Output number	S: single output
④	Rated output voltage	05: 5V output
⑤	Remote ON/OFF logic	Default: negative; P: positive logic
⑥	Baseplated	Default:no baseplated ; B: baseplated
⑦	Pin length	-4: 4.8mm
⑧	RoHS status	L: RoHS, R6; Y: RoHS, R5

Model number	Description
AVQ100-24S05-4L	4.8mm pin length; negative on/off logic; open frame; R6 compliant
AVQ100-24S05P-4L	4.8mm pin length; positive on/off logic; open frame; R6 compliant
AVQ100-24S05B-4L	4.8mm pin length; negative on/off logic;with baseplated;without thread inside mounting hole; R6 compliant; for detailed information,refer to AVQ100-24S05B Technical Reference Notes
AVQ100-24S05PB-4L	4.8mm pin length; positive on/off logic;with baseplated;without thread inside mounting hole; R6 compliant; for detailed information,refer to AVQ100-24S05B Technical Reference Notes

Hazardous Substances Announcement (RoHS Of China)

Parts	Hazardous substances					
	Pb	Hg	Cd	Cr ⁶⁺	PBB	PBDE
AVQ100-24S05	○	○	○	○	○	○
○: Means the content of the hazardous substances in all the average quality materials of the part is within the limits specified in SJ/T-11363-2006 √: Means the content of the hazardous substances in at least one of the average quality materials of the part is outside the limits specified in SJ/T11363-2006						
Emerson Network Power Co., Ltd. has been committed to the design and manufacturing of environment-friendly products. It will reduce and eventually eliminate the hazardous substances in the products through unremitting efforts in research. However, limited by the current technical level, the following parts still contain hazardous substances due to the lack of reliable substitute or mature solution:						
1. Solders (including high-temperature solder in parts) contain plumbum. 2. Glass of electric parts contains plumbum. 3. Copper alloy of pins contains plumbum						



Компания «ЭлектроПласт» предлагает заключение долгосрочных отношений при поставках импортных электронных компонентов на взаимовыгодных условиях!

Наши преимущества:

- Оперативные поставки широкого спектра электронных компонентов отечественного и импортного производства напрямую от производителей и с крупнейших мировых складов;
- Поставка более 17-ти миллионов наименований электронных компонентов;
- Поставка сложных, дефицитных, либо снятых с производства позиций;
- Оперативные сроки поставки под заказ (от 5 рабочих дней);
- Экспресс доставка в любую точку России;
- Техническая поддержка проекта, помощь в подборе аналогов, поставка прототипов;
- Система менеджмента качества сертифицирована по Международному стандарту ISO 9001;
- Лицензия ФСБ на осуществление работ с использованием сведений, составляющих государственную тайну;
- Поставка специализированных компонентов (Xilinx, Altera, Analog Devices, Intersil, Interpoint, Microsemi, Aeroflex, Peregrine, Syfer, Eurofarad, Texas Instrument, Miteq, Cobham, E2V, MA-COM, Hittite, Mini-Circuits, General Dynamics и др.);

Помимо этого, одним из направлений компании «ЭлектроПласт» является направление «Источники питания». Мы предлагаем Вам помощь Конструкторского отдела:

- Подбор оптимального решения, техническое обоснование при выборе компонента;
- Подбор аналогов;
- Консультации по применению компонента;
- Поставка образцов и прототипов;
- Техническая поддержка проекта;
- Защита от снятия компонента с производства.



Как с нами связаться

Телефон: 8 (812) 309 58 32 (многоканальный)

Факс: 8 (812) 320-02-42

Электронная почта: org@eplast1.ru

Адрес: 198099, г. Санкт-Петербург, ул. Калинина, дом 2, корпус 4, литера А.