

AUTOMOTIVE COMPLIANT 1.24V ADJUSTABLE PRECISION SHUNT REGULATOR

Description

The AZ9431BQ series are three-terminal adjustable shunt regulators with guaranteed thermal stability over a full operation range. These ICs feature sharp turn-on characteristics, low temperature coefficient, and low output impedance, which make them ideal substitutes for zener diodes in automotive and high-reliability applications requiring an improvement in zener performance.

The output voltage can be set to any value between 1.24V and 18V with two external resistors.

The AZ9431BQ precision reference is offered in 1.0% voltage tolerance.

The AZ9431BQ are available SOT23 that are qualified to AEC Q100 standards for high reliability and are PPAP capable.

Pin Assignments

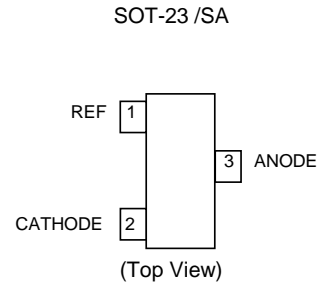

Features

- Wide Programmable Precise Output Voltage from 1.24V to 18V
- Temperature Range -40°C to +125°C
- Reference Voltage Tolerance at +25°C
 - 1% AZ9431BQSA-7
- High Stability Under Capacitive Load
- Low Temperature Deviation: 3mV Typical
- Low Equivalent Full-Range Temperature Coefficient: 20PPM/°C
- Low Dynamic Output Resistance: 0.05Ω Typical
- High-Sink Current Capacity from 0.1mA to 100mA
- Low Output Noise
- Wide Operating Range of -40°C to +125°C
- Green Molding
- **Totally Lead-Free & Fully RoHS Compliant (Notes 1 & 2)**
- **Halogen and Antimony Free. "Green" Device (Note 3)**
- **Qualified to AEC-Q100 Standards for High Reliability**
- **PPAP Capable (Note 4)**

Typical Applications Circuit

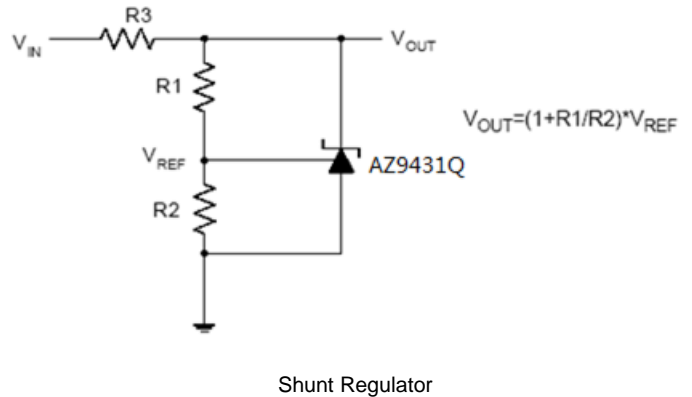

Notes:

1. No purposely added lead. Fully EU Directive 2002/95/EC (RoHS), 2011/65/EU (RoHS 2) & 2015/863/EU (RoHS 3) compliant.
2. See <https://www.diodes.com/quality/lead-free/> for more information about Diodes Incorporated's definitions of Halogen- and Antimony-free, "Green" and Lead-free.
3. Halogen- and Antimony-free "Green" products are defined as those which contain <900ppm bromine, <900ppm chlorine (<1500ppm total Br + Cl) and <1000ppm antimony compounds.
4. Automotive products are AEC-Q100 qualified and are PPAP capable. Refer to <https://www.diodes.com/quality/>.

Functional Block Diagram

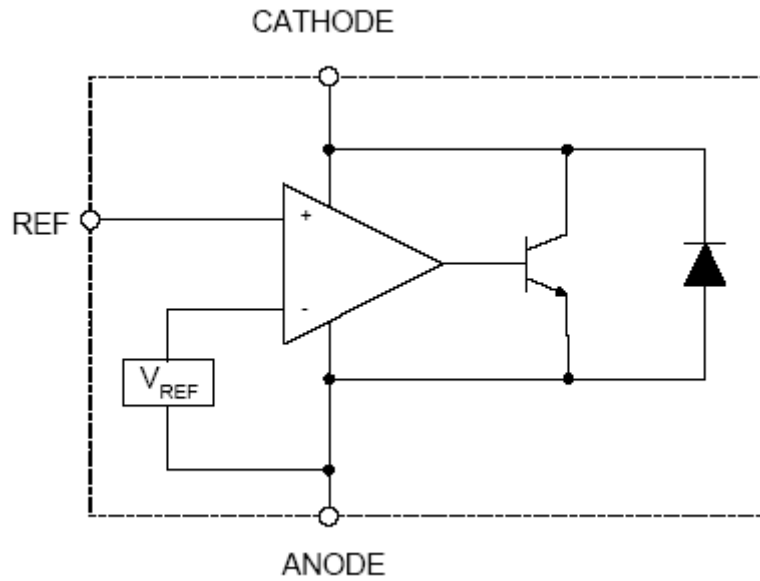

Absolute Maximum Ratings (Note 5)

Symbol	Parameter	Rating	Unit
V_{KA}	Cathode Voltage	20	V
I_{KA}	Cathode Current Range (Continuous)	-100 to 100	mA
I_{REF}	Reference Input Current Range	10	mA
P_D	Power Dissipation	370	mW
T_J	Junction Temperature	+150	°C
T_{STG}	Storage Temperature Range	-65 to +150	°C

Note: 5. Stresses greater than those listed under *Absolute Maximum Ratings* can cause permanent damage to the device. These are stress ratings only, and functional operation of the device at these or any other conditions beyond those indicated under *Recommended Operating Conditions* is not implied. Exposure to *Absolute Maximum Ratings* for extended periods may affect device reliability.

ESD Susceptibility		
Human Body Model	±6	kV
Machine Model	±300	V
Charged Device Model	±1.5	kV

Semiconductor devices are ESD sensitive and can be damaged by exposure to ESD events. Suitable ESD precautions must be taken when handling and transporting these devices.

Recommended Operating Conditions

Symbol	Parameter	Min	Max	Unit
V_{KA}	Cathode Voltage	V_{REF}	18	V
I_{KA}	Cathode Current	0.1	100	mA
T_A	Operating Ambient Temperature Range	-40	+125	°C

Electrical Characteristics (Operating Conditions: $T_A = +25\text{ }^\circ\text{C}$, unless otherwise noted.)

Symbol	Parameter	Test Circuit	Conditions	Min	Typ	Max	Unit		
V_{REF}	Reference Voltage	1.0%	4	$V_{KA} = V_{REF}$, $I_{KA} = 10\text{mA}$	AZ9431BQ	1.228	1.24	1.252	V
ΔV_{REF}	Deviation of Reference Voltage Over Full Temperature Range	4	$V_{KA} = V_{REF}$, $I_{KA} = 10\text{mA}$	$0^\circ\text{C to } +70^\circ\text{C}$	—	2	10	mV	
				$-40^\circ\text{C to } +85^\circ\text{C}$	—	3	10		
				$-40^\circ\text{C to } +125^\circ\text{C}$	—	4	15		
$\frac{\Delta V_{REF}}{\Delta V_{KA}}$	Ratio of Change in V_{REF} to the Change in Cathode Voltage	5	$I_{KA} = 10\text{mA}$, $\Delta V_{KA}: V_{REF} \text{ to } 16\text{V}$	—	-0.5	-1.5	mV/V		
I_{REF}	Reference Input Current	5	$I_{KA} = 10\text{mA}$, $R_1 = 10\text{k}\Omega$, $R_2 = \infty$	—	0.15	0.4	μA		
ΔI_{REF}	Deviation of Reference Current Over Full Temperature Range	5	$I_{KA} = 10\text{mA}$, $R_1 = 10\text{k}\Omega$, $R_2 = \infty$, $T_A = -40^\circ\text{C to } +125^\circ\text{C}$	—	0.1	0.4	μA		
I_{KA} (Min)	Minimum Cathode Current for Regulation	4	$V_{KA} = V_{REF}$	—	55	80	μA		
I_{KA} (Off)	Off-State Cathode Current	6	$V_{REF} = 0$, $V_{KA} = 18\text{V}$	—	0.04	0.10	μA		
			$V_{KA} = 6\text{V}$, $V_{REF} = 0$	—	0.01	0.05			
Z_{KA}	Dynamic Impedance	4	$V_{KA} = V_{REF}$, $I_{KA} = 1\text{mA to } 100\text{mA}$, $f \leq 1.0\text{kHz}$	—	0.05	0.15	Ω		
θ_{JC}	Thermal Resistance (Note 6)	—	—	—	45	—	$^\circ\text{C/W}$		

Note: 6. Test condition for SOT23: device mounted on 1"x1" FR-4 MRP substrate PCB, 2oz copper, with minimum recommended pad layout.

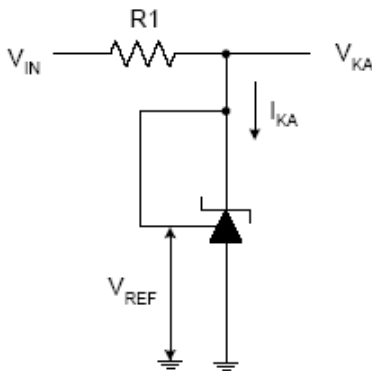
Test Circuits

Test Circuit 4 for $V_{KA} = V_{REF}$

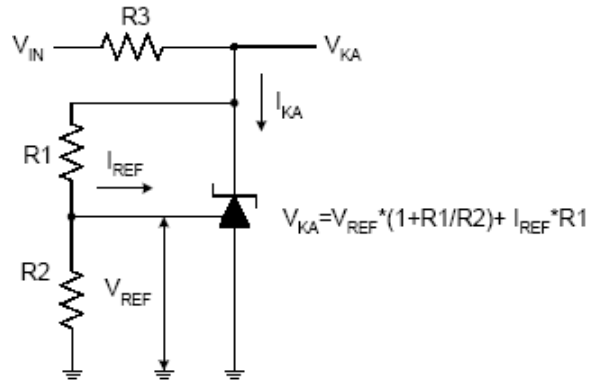

Test Circuit 5 for $V_{KA} > V_{REF}$

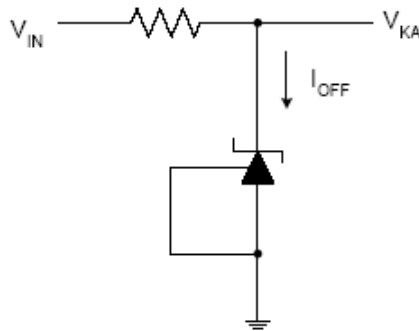

Test Circuit 6 for I_{OFF}

Performance Characteristics

Reference Voltage vs. Ambient Temperature

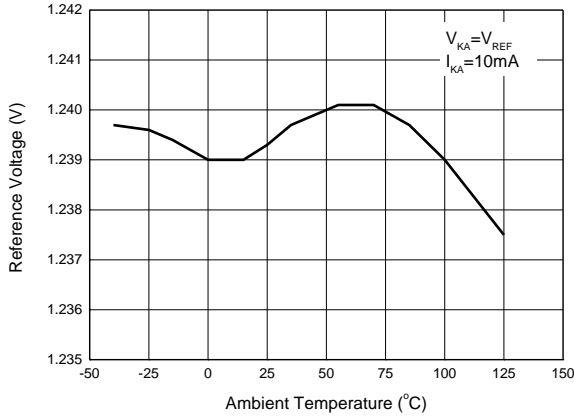

Reference Current vs. Ambient Temperature

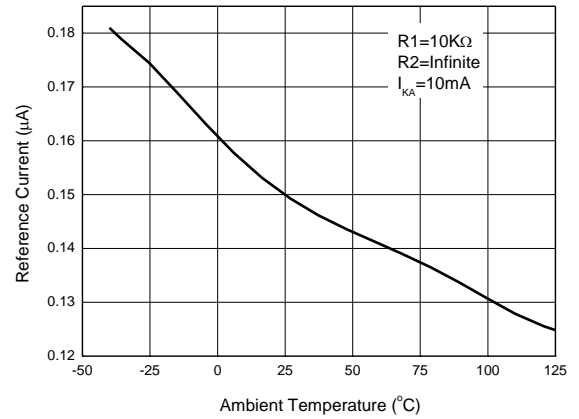

Cathode Current vs. Cathode Voltage

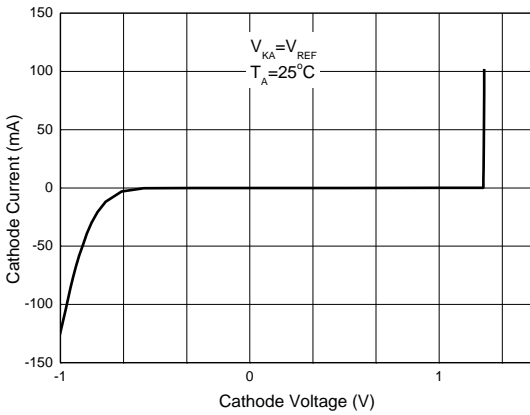

Cathode Current vs. Cathode Voltage

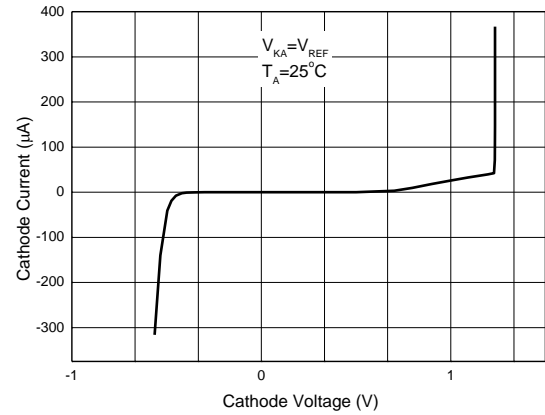

Small Signal Voltage Gain vs. Frequency

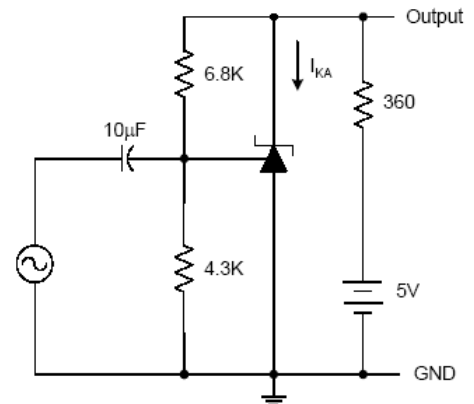
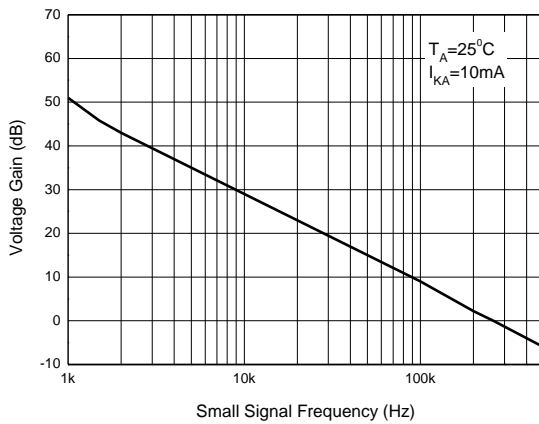

Performance Characteristics (continued)

Dynamic Impedance vs. Frequency

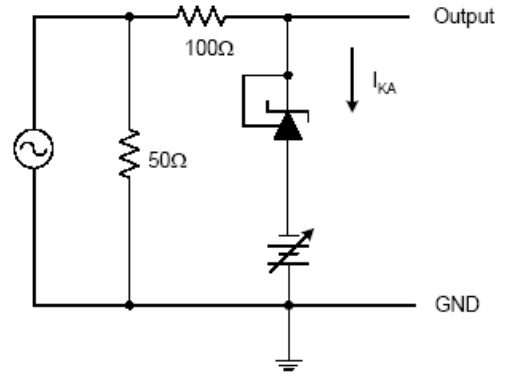
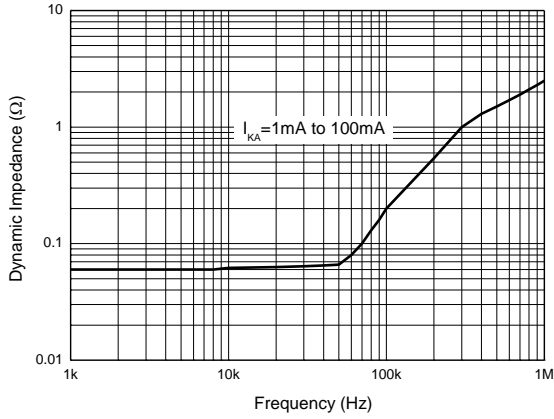

Pulse Response of Input and Output Voltage

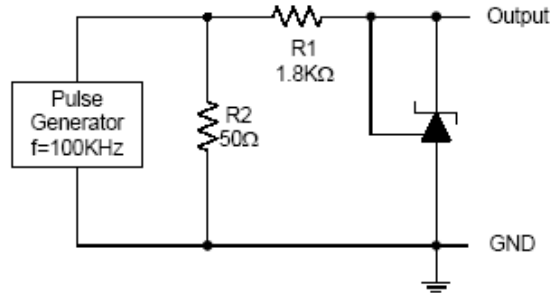
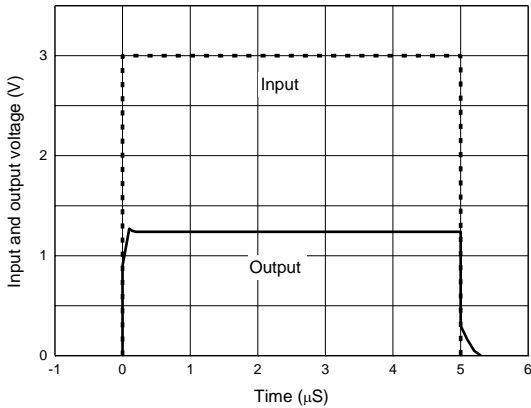

Ratio of Delta Reference Voltage to the Ratio of Cathode Voltage vs. Ambient Temperature

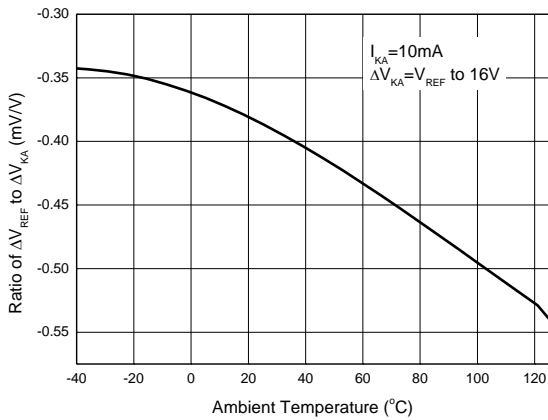

Stability Boundary Conditions vs. Load Capacitance

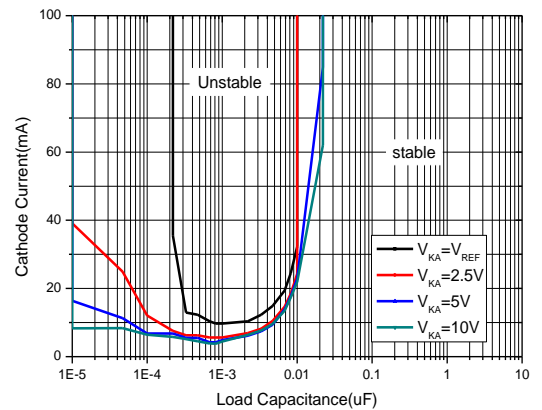

Typical Applications Circuit

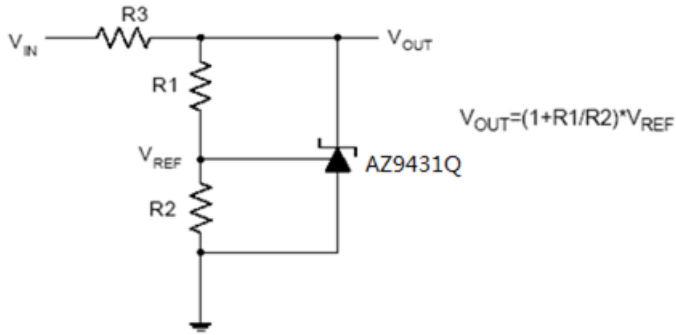

Shunt Regulator

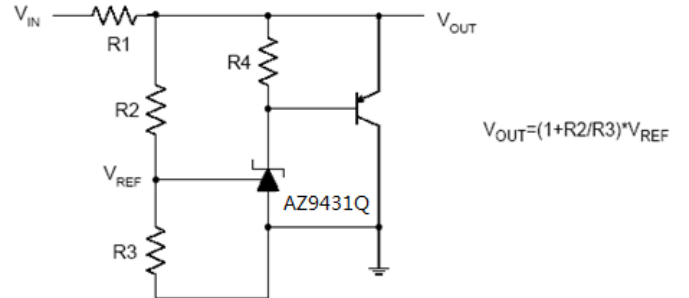

High Current Shunt Regulator

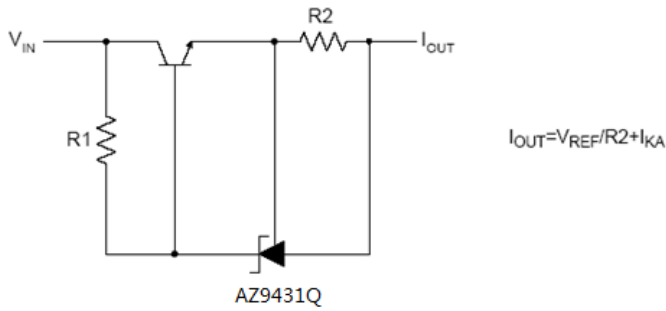

Current Source or Current Limit

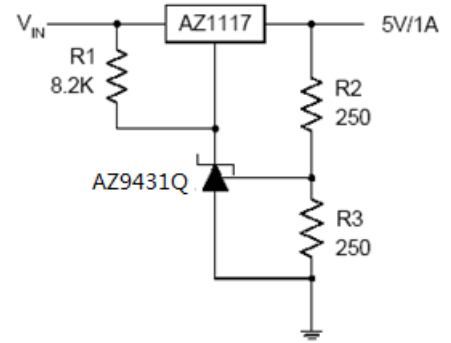

Precision 5V 1A Regulator

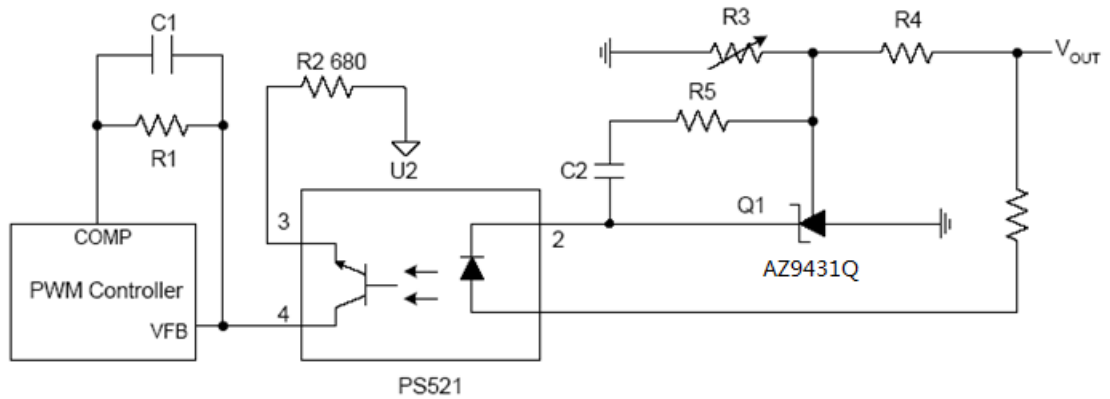

PWM Converter with Reference

Ordering Information

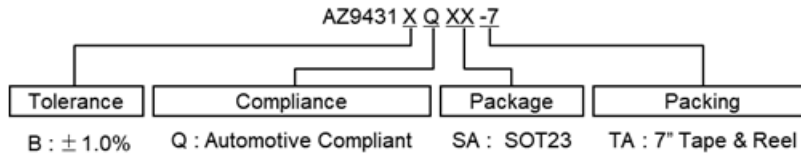

Device	Package Code	Packaging (Note 7)	Compliance (Note 8)	7"/13" Tape and Reel	
				Quantity	Part Number Suffix
AZ9431BQ	SA	SOT23	Automotive Compliant	3000/Tape & Reel	-7

Notes: 7. For packaging details, go to our website at <https://www.diodes.com/design/support/packaging/diodes-packaging/>.
 8. AZ9431BQ have been qualified to AEC-Q100 Grade 1 and are classified as *Automotive-Compliant* supporting PPAP documentation. See AZ431L datasheet for commercial qualified versions.

Marking Information

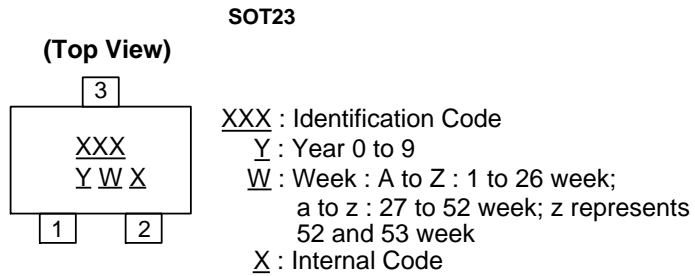

Part Number	Package	Identification Code
AZ9431BQSA-7	SOT23	DYQ

Package Outline Dimensions

Please see <http://www.diodes.com/package-outlines.html> for the latest version.

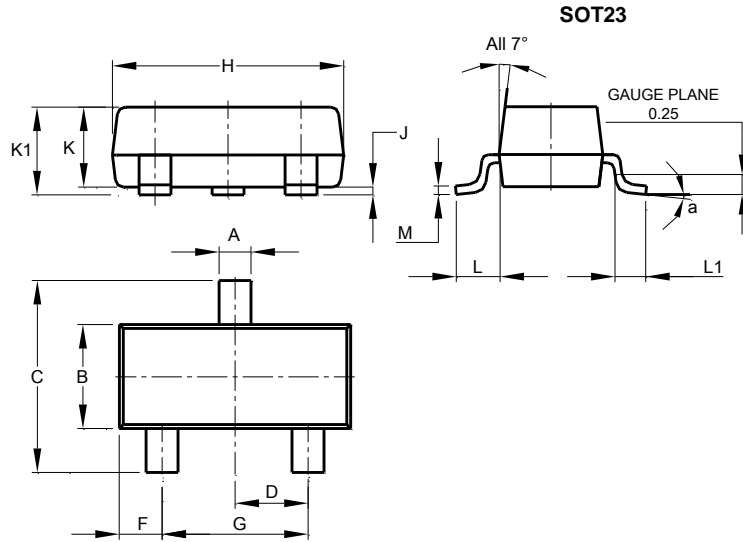

SOT23			
Dim	Min	Max	Typ
A	0.37	0.51	0.40
B	1.20	1.40	1.30
C	2.30	2.50	2.40
D	0.89	1.03	0.915
F	0.45	0.60	0.535
G	1.78	2.05	1.83
H	2.80	3.00	2.90
J	0.013	0.10	0.05
K	0.890	1.00	0.975
K1	0.903	1.10	1.025
L	0.45	0.61	0.55
L1	0.25	0.55	0.40
M	0.085	0.150	0.110
a	0°	8°	--
All Dimensions in mm			

Suggested Pad Layout

Please see <http://www.diodes.com/package-outlines.html> for the latest version.

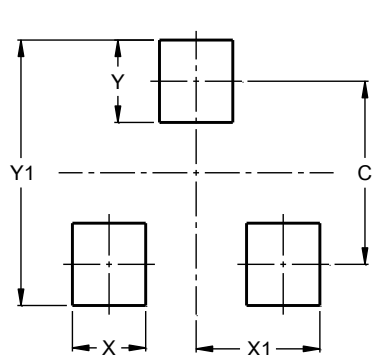

Dimensions	Value (in mm)
C	2.0
X	0.8
X1	1.35
Y	0.9
Y1	2.9

Note: 9. The suggested land pattern dimensions have been provided for reference only, as actual pad layouts may vary depending on application. These dimensions may be modified based on user equipment capability or fabrication criteria. A more robust pattern may be desired for wave soldering and is calculated by adding 0.2 mm to the 'Z' dimension. For further information, please reference document IPC-7351A, Naming Convention for Standard SMT Land Patterns, and for International grid details, please see document IEC, Publication 97.

IMPORTANT NOTICE

DIODES INCORPORATED MAKES NO WARRANTY OF ANY KIND, EXPRESS OR IMPLIED, WITH REGARDS TO THIS DOCUMENT, INCLUDING, BUT NOT LIMITED TO, THE IMPLIED WARRANTIES OF MERCHANTABILITY AND FITNESS FOR A PARTICULAR PURPOSE (AND THEIR EQUIVALENTS UNDER THE LAWS OF ANY JURISDICTION).

Diodes Incorporated and its subsidiaries reserve the right to make modifications, enhancements, improvements, corrections or other changes without further notice to this document and any product described herein. Diodes Incorporated does not assume any liability arising out of the application or use of this document or any product described herein; neither does Diodes Incorporated convey any license under its patent or trademark rights, nor the rights of others. Any Customer or user of this document or products described herein in such applications shall assume all risks of such use and will agree to hold Diodes Incorporated and all the companies whose products are represented on Diodes Incorporated website, harmless against all damages.

Diodes Incorporated does not warrant or accept any liability whatsoever in respect of any products purchased through unauthorized sales channel. Should Customers purchase or use Diodes Incorporated products for any unintended or unauthorized application, Customers shall indemnify and hold Diodes Incorporated and its representatives harmless against all claims, damages, expenses, and attorney fees arising out of, directly or indirectly, any claim of personal injury or death associated with such unintended or unauthorized application.

Products described herein may be covered by one or more United States, international or foreign patents pending. Product names and markings noted herein may also be covered by one or more United States, international or foreign trademarks.

This document is written in English but may be translated into multiple languages for reference. Only the English version of this document is the final and determinative format released by Diodes Incorporated.

LIFE SUPPORT

Diodes Incorporated products are specifically not authorized for use as critical components in life support devices or systems without the express written approval of the Chief Executive Officer of Diodes Incorporated. As used herein:

A. Life support devices or systems are devices or systems which:

1. are intended to implant into the body, or
2. support or sustain life and whose failure to perform when properly used in accordance with instructions for use provided in the labeling can be reasonably expected to result in significant injury to the user.

B. A critical component is any component in a life support device or system whose failure to perform can be reasonably expected to cause the failure of the life support device or to affect its safety or effectiveness.

Customers represent that they have all necessary expertise in the safety and regulatory ramifications of their life support devices or systems, and acknowledge and agree that they are solely responsible for all legal, regulatory and safety-related requirements concerning their products and any use of Diodes Incorporated products in such safety-critical, life support devices or systems, notwithstanding any devices- or systems-related information or support that may be provided by Diodes Incorporated. Further, Customers must fully indemnify Diodes Incorporated and its representatives against any damages arising out of the use of Diodes Incorporated products in such safety-critical, life support devices or systems.

Copyright © 2018, Diodes Incorporated

www.diodes.com



Компания «ЭлектроПласт» предлагает заключение долгосрочных отношений при поставках импортных электронных компонентов на взаимовыгодных условиях!

Наши преимущества:

- Оперативные поставки широкого спектра электронных компонентов отечественного и импортного производства напрямую от производителей и с крупнейших мировых складов;
- Поставка более 17-ти миллионов наименований электронных компонентов;
- Поставка сложных, дефицитных, либо снятых с производства позиций;
- Оперативные сроки поставки под заказ (от 5 рабочих дней);
- Экспресс доставка в любую точку России;
- Техническая поддержка проекта, помощь в подборе аналогов, поставка прототипов;
- Система менеджмента качества сертифицирована по Международному стандарту ISO 9001;
- Лицензия ФСБ на осуществление работ с использованием сведений, составляющих государственную тайну;
- Поставка специализированных компонентов (Xilinx, Altera, Analog Devices, Intersil, Interpoint, Microsemi, Aeroflex, Peregrine, Syfer, Eurofarad, Texas Instrument, Miteq, Cobham, E2V, MA-COM, Hittite, Mini-Circuits, General Dynamics и др.);

Помимо этого, одним из направлений компании «ЭлектроПласт» является направление «Источники питания». Мы предлагаем Вам помощь Конструкторского отдела:

- Подбор оптимального решения, техническое обоснование при выборе компонента;
- Подбор аналогов;
- Консультации по применению компонента;
- Поставка образцов и прототипов;
- Техническая поддержка проекта;
- Защита от снятия компонента с производства.



Как с нами связаться

Телефон: 8 (812) 309 58 32 (многоканальный)

Факс: 8 (812) 320-02-42

Электронная почта: org@eplast1.ru

Адрес: 198099, г. Санкт-Петербург, ул. Калинина, дом 2, корпус 4, литера А.