



Features

- Single Power Supply 3.0V to 3.6V
- 30dB Typical Gain, Input Matched to 50Ω
- 2.4GHz to 2.5GHz Frequency Range
- 11g P_{OUT} = +18dBm @ 3% Typ EVM, 95mA

Applications

- IEEE802.11b/g/n WiFi Applications
- 2.5GHz ISM Band Applications
- Commercial and Consumer Systems
- Portable Battery-Powered Equipment
- Spread-Spectrum and MMDS Systems

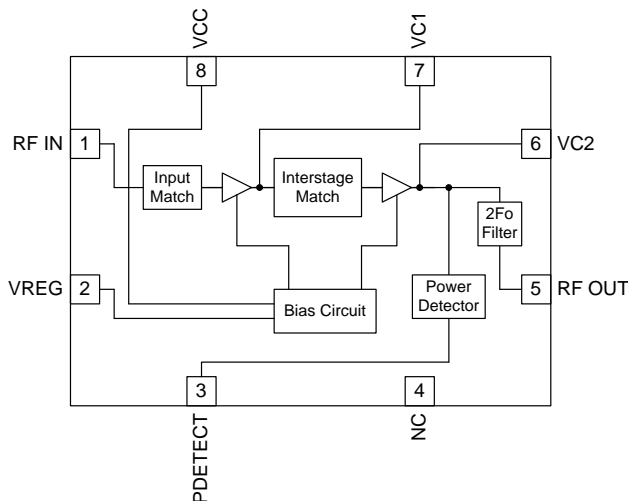

Functional Block Diagram

Product Description

The RF5622 is a linear, medium-power, high-efficiency, two-stage amplifier IC designed specifically for battery-powered WiFi applications such as PC cards, mini PCI, and compact flash applications. The device is manufactured on an advanced InGaP Gallium Arsenide Heterojunction Bipolar Transistor (HBT) process, and has been designed for use as the final RF amplifier in 2.5GHz OFDM and other spread-spectrum transmitters. The device is provided in a 2.2mmx2.2mmx0.45mm, 8-pin, QFN with a back-side ground. The RF5622 is designed to maintain linearity over a wide range of supply voltage and power output. The RF5622 also has built-in power detector and incorporates the input and interstage matching components internally which reduces the component count used externally and makes it easier to incorporate on any design.

Ordering Information

| | |
|---------------|---|
| RF5622 | Standard 25 piece bag |
| RF5622SR | Standard 100 piece reel |
| RF5622TR7 | Standard 2500 piece reel |
| RF5622PCK-410 | Fully assembled evaluation board tuned for 2.4GHz to 2.5GHz and 5 piece loose samples |

Optimum Technology Matching® Applied

- | | | | |
|---|--------------------------------------|-------------------------------------|-----------------------------------|
| <input type="checkbox"/> GaAs HBT | <input type="checkbox"/> SiGe BiCMOS | <input type="checkbox"/> GaAs pHEMT | <input type="checkbox"/> GaN HEMT |
| <input type="checkbox"/> GaAs MESFET | <input type="checkbox"/> Si BiCMOS | <input type="checkbox"/> Si CMOS | |
| <input checked="" type="checkbox"/> InGaP HBT | <input type="checkbox"/> SiGe HBT | <input type="checkbox"/> Si BJT | |

RF MICRO DEVICES®, RFMD®, Optimum Technology Matching®, Enabling Wireless Connectivity™, PowerStar®, POLARIS™ TOTAL RADIO™ and UltimateBlue™ are trademarks of RFMD, LLC. BLUETOOTH is a trademark owned by Bluetooth SIG, Inc., U.S.A. and licensed for use by RFMD. All other trade names, trademarks and registered trademarks are the property of their respective owners. ©2006, RF Micro Devices, Inc.

Absolute Maximum Ratings

| Parameter | Rating | Unit |
|---|---------------|-----------------|
| Supply Voltage | -0.5 to +5.0 | V _{DC} |
| Power Control Voltage (V _{REG}) | -0.5 to +3.3 | V |
| DC Supply Current | 240 | mA |
| Input RF Power | +5 | dBm |
| Extreme Operating Temperature | -30 to +85 | °C |
| Full Specification Temperature Range | -15 to +85 | °C |
| Storage Temperature | -40 to +150 | °C |
| Moisture sensitivity | JEDEC Level 2 | |



Caution! ESD sensitive device.

Exceeding any one or a combination of the Absolute Maximum Rating conditions may cause permanent damage to the device. Extended application of Absolute Maximum Rating conditions to the device may reduce device reliability. Specified typical performance or functional operation of the device under Absolute Maximum Rating conditions is not implied.

RoHS status based on EU Directive 2002/95/EC (at time of this document revision).

The information in this publication is believed to be accurate and reliable. However, no responsibility is assumed by RF Micro Devices, Inc. ("RFMD") for its use, nor for any infringement of patents, or other rights of third parties, resulting from its use. No license is granted by implication or otherwise under any patent or patent rights of RFMD. RFMD reserves the right to change component circuitry, recommended application circuitry and specifications at any time without prior notice.

| Parameter | Specification | | | Unit | Condition |
|--------------------------------|---------------|--------------------------|-------|-----------------|---|
| | Min. | Typ. | Max. | | |
| IEEE802.11g | | | | | Temperature = +25°C, V _{CC} = 3.3V, V _{REG} = 2.8V pulsed at 1% to 100% duty cycle, Frequency = 2450MHz, circuit per evaluation board schematic, unless otherwise specified |
| Frequency | 2.4 | | 2.5 | GHz | IEEE802.11g IEEE802.11n |
| Output Power | | 13 | | dBm | At max data rate, OFDM modulation RMS, mean, V _{CC} = 2.8V |
| | | 18 | | dBm | At max data rate, OFDM modulation RMS, mean, V _{CC} = 3.3V |
| EVM* | | 3.0 | 4.0 | % | RMS, mean |
| Gain | 26 | 30 | | dB | At +18dBm RF P _{OUT} and 54Mbps |
| Gain Variance Over Temperature | | | 1.5 | ±dB | -30°C to +85°C, 2.4GHz to 2.5GHz |
| Power Detector | | | | | |
| | | P _{OUT} = 8dBm | 0.320 | V | |
| | | P _{OUT} = 18dBm | 1.2 | V | |
| Power Supply | 2.8 | 3.3 | 3.6 | V _{DC} | |
| V _{REG} Input Voltage | 2.75 | 2.8 | 3.0 | V _{DC} | Operating |
| Output VSWR | | | 10:1 | | No damage to the PA |
| Input Return Loss | | -15 | -10 | dB | |
| Turn-on Time** | | 0.5 | 1.8 | µS | Output stable to within 90% of final gain |
| Second Harmonic | | | -43 | dBm | Fundamental frequency is between 2.4GHz and 2.5GHz; RFP _{OUT} = +18dBm, 1Mbps CCK IEEE802.11b modulation |
| Current Consumption | | | | | |
| Quiescent Current | | 55 | | mA | Data rate @ ≤3.5% EVM RMS, mean |
| Operating Current | | 70 | | mA | P _{OUT} = +13dBm, V _{CC} = 2.8V |
| | | 95 | | mA | P _{OUT} = +18dBm, V _{CC} = 3.3V, diff. output match required |
| I _{REG} Current | | 2 | 6 | mA | V _{CC} = +3.3V _{DC} |
| Shutdown Current | | 0.5 | 10 | µA | |

Notes:

*The EVM specification is obtained with a signal generator that has an EVM floor of less than 0.7%.

**The PA must operate with gated bias voltage input at 1% to 99% duty cycles without any EVM or other parameter degradation.

| Pin | Function | Description |
|----------|---------------|---|
| 1 | RF IN | RF input. Input is matched to 50Ω and DC block is provided internally. |
| 2 | VREG | Bias current control voltage for the first and second amplifier stage. |
| 3 | PDETECT or NC | Power detector which provides an output voltage proportional to the RF output power level. May need external decoupling capacitor for load sensitivity. May be left unconnected if function is not desired. |
| 4 | NC | This pin may be left unconnected or may be connected to ground. |
| 5 | RF OUT | RF output. A DC blocking capacitor may be needed as this pin of the PA is a DC short to ground. |
| 6 | VC2 | Voltage supply for second stage amplifier. External low frequency bypass capacitors should be connected if no other low frequency decoupling is employed. |
| 7 | VC1 | Voltage supply for the first amplifier stage. External low frequency bypass capacitors should be connected if no other low frequency decoupling is employed. |
| 8 | VCC | Supply voltage for the bias reference and control circuit. May be connected with V _{C1} and V _{C2} (with a single supply voltage). The 56pF bypass capacitor on the V _{CC} line should be placed as close as possible to the IC. |
| Pkg Base | GND | The center metal base of the QFN package provides DC and RF ground as well as heat sink for the amplifier. |

Package Drawing

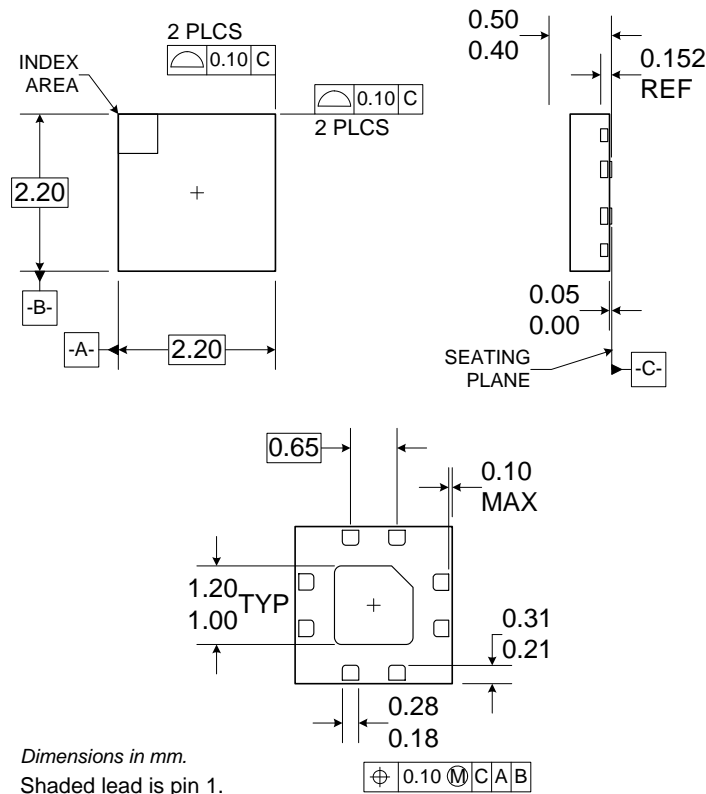

Pin Out

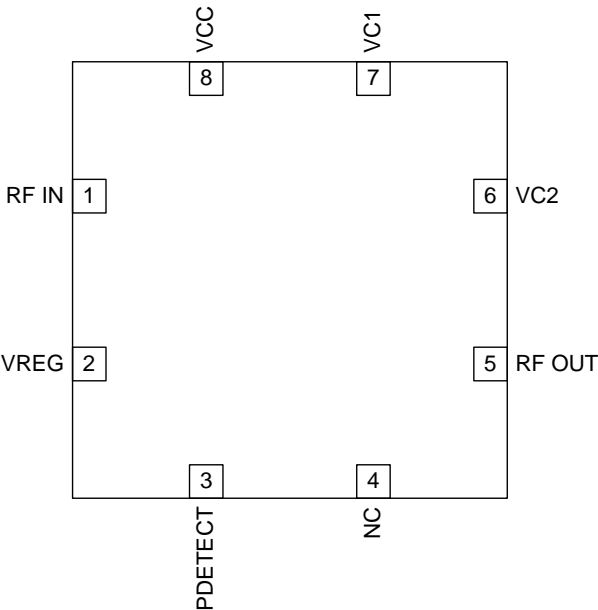

Theory of Operation and Application Information

The RF5622 is a two-stage power amplifier (PA) with a typical gain of 30dB in the 2.4GHz to 2.5GHz ISM band. The RF5622 has integrated input and interstage matching components thus allowing a minimal bill of material (BOM) part count in end applications. The RF5622 is designed primarily for IEEE802.11b/g/n WiFi applications where the available supply voltage and current are limited. This amplifier will operate to (and below) the lowest expected voltage made available by a typical PCMCIA slot in a laptop PC, and will maintain required linearity at decreased supply voltages. The device is provided in a 2mmx2mmx0.45mm, 8-pin, QFN with backside ground.

The RF5622 requires only a single positive supply of 3.3V nominal to operate to full specifications. Power control is provided through one bias voltage pin (V_{REG}). The input DC blocking cap is provided internally, the output of the PA is not internally DC blocked. The evaluation board circuit (available from RF Micro Devices, Inc. (RFMD)) is optimized for $3.3V_{DC}$ applications. For best performance, it is important to duplicate (as closely as possible) the layout of the evaluation board. The RF5622 has primarily been characterized with a voltage on V_{REG} of $2.8V_{DC}$. If you prefer to use a bias voltage that is significantly different than $2.8V_{DC}$, or a different frequency than the recommended frequency range, contact RFMD Sales or Applications Engineering for additional data and guidance.

For best results, the PA circuit layout from the evaluation board should be copied as closely as possible, particularly the ground layout and ground vias. Other configurations may also work, but the design process is much easier and quicker if the layout is copied from the RF5622 evaluation board. Gerber files of RFMD PCBA designs can be provided on request. The RF5622 is a very easy part to implement, but care in circuit layout and component selection is always advisable when designing circuits to operate at 2.5GHz. The RF5622 evaluation board layout and schematic are available using 0201 (US) size components which will help shrink the overall size of the total area of the PA and components of the intended design. If you prefer to use a supply or bias voltage that is significantly different than what is specified, or a different frequency than the recommended frequency range, contact RFMD Sales or Applications Engineering for additional data and guidance.

Application Schematic

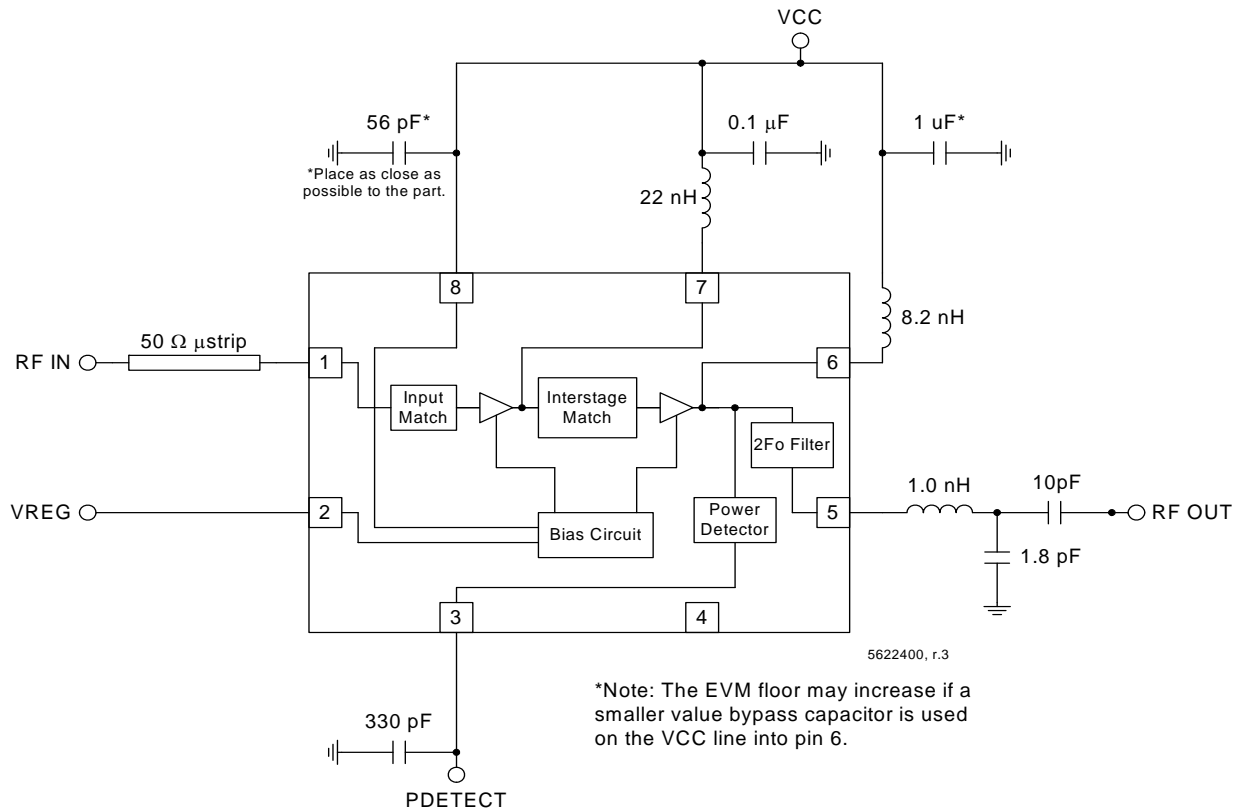

**Evaluation Board Schematic (PROTOTYPE)
IEEE802.11b/g**

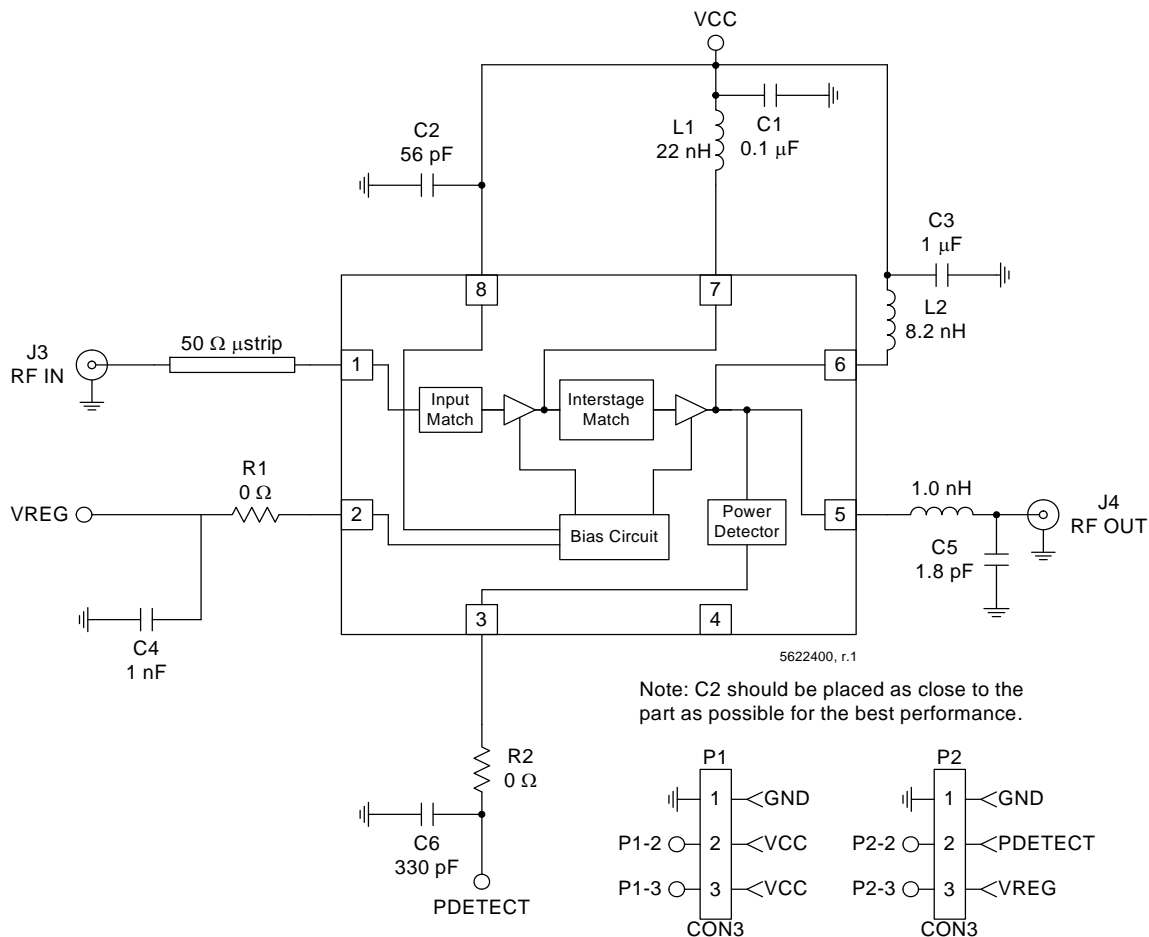

Evaluation Board Layout Board Size 1.2" x 1.2" Board Thickness 0.032", Board Material FR-4

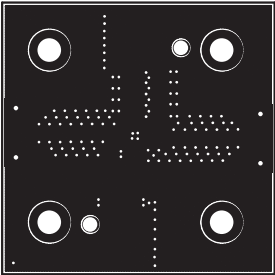
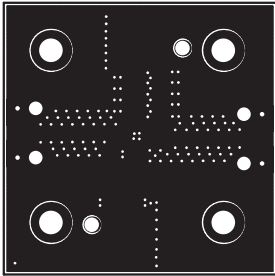
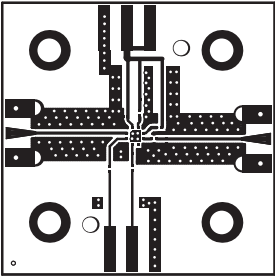
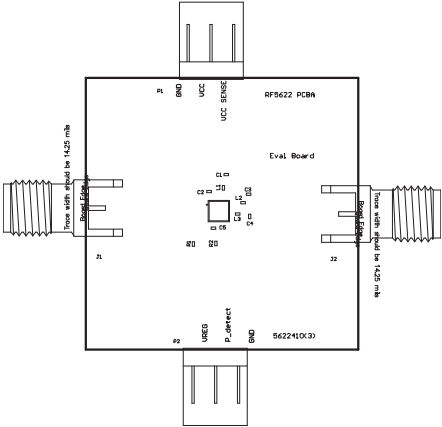

V_{CC}=3.3V: EVM versus P_{OUT}

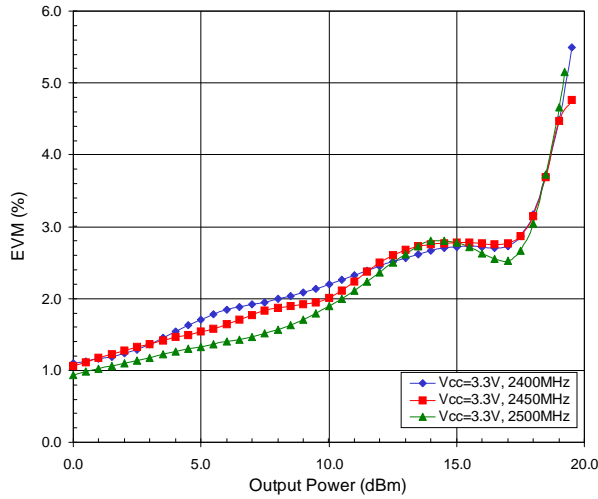

V_{CC}=2.8V: EVM versus P_{OUT}

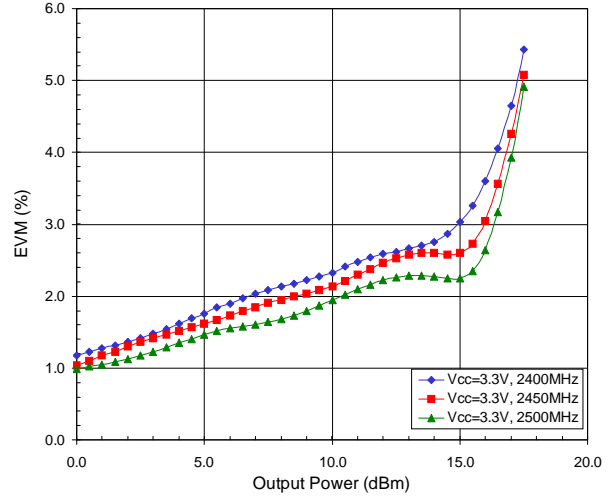

Gain versus Frequency
P_{OUT}=+18dBm

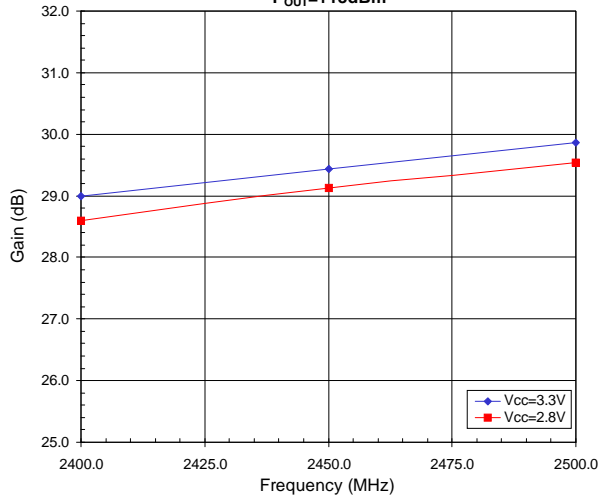

V_{CC}=3.3V: I_{CC} versus P_{OUT}

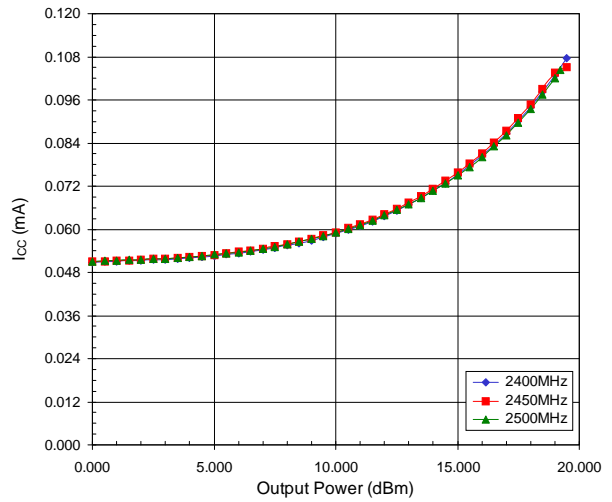

V_{CC}=2.8V: I_{CC} versus P_{OUT}

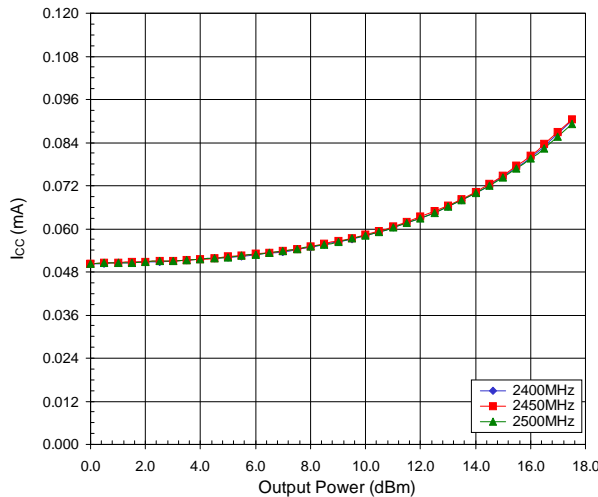

P_{DETECT} versus P_{OUT}

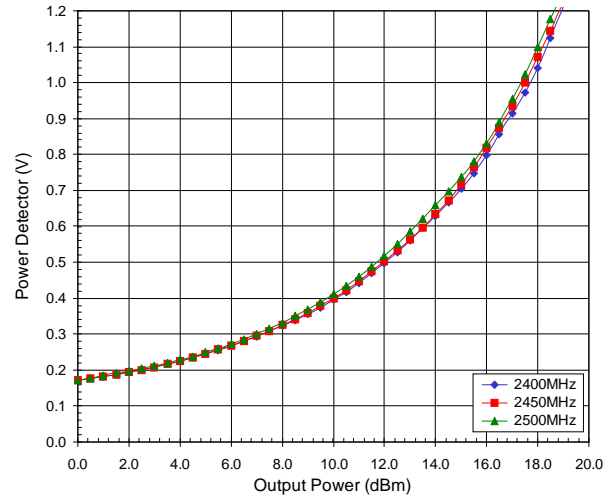



Компания «ЭлектроПласт» предлагает заключение долгосрочных отношений при поставках импортных электронных компонентов на взаимовыгодных условиях!

Наши преимущества:

- Оперативные поставки широкого спектра электронных компонентов отечественного и импортного производства напрямую от производителей и с крупнейших мировых складов;
- Поставка более 17-ти миллионов наименований электронных компонентов;
- Поставка сложных, дефицитных, либо снятых с производства позиций;
- Оперативные сроки поставки под заказ (от 5 рабочих дней);
- Экспресс доставка в любую точку России;
- Техническая поддержка проекта, помощь в подборе аналогов, поставка прототипов;
- Система менеджмента качества сертифицирована по Международному стандарту ISO 9001;
- Лицензия ФСБ на осуществление работ с использованием сведений, составляющих государственную тайну;
- Поставка специализированных компонентов (Xilinx, Altera, Analog Devices, Intersil, Interpoint, Microsemi, Aeroflex, Peregrine, Syfer, Eurofarad, Texas Instrument, Miteq, Cobham, E2V, MA-COM, Hittite, Mini-Circuits, General Dynamics и др.);

Помимо этого, одним из направлений компании «ЭлектроПласт» является направление «Источники питания». Мы предлагаем Вам помощь Конструкторского отдела:

- Подбор оптимального решения, техническое обоснование при выборе компонента;
- Подбор аналогов;
- Консультации по применению компонента;
- Поставка образцов и прототипов;
- Техническая поддержка проекта;
- Защита от снятия компонента с производства.



Как с нами связаться

Телефон: 8 (812) 309 58 32 (многоканальный)

Факс: 8 (812) 320-02-42

Электронная почта: org@eplast1.ru

Адрес: 198099, г. Санкт-Петербург, ул. Калинина, дом 2, корпус 4, литера А.