

SINGLE SCHMITT-TRIGGER INVERTER

Description

The 74LVC1G14 is a single 1-input Schmitt-trigger inverter with a standard push-pull output. The device is designed for operation with a power supply range of 1.65V to 5.5V. The inputs are tolerant to 5.5V allowing this device to be used in a mixed voltage environment. The device is fully specified for partial power down applications using I_{OFF}. The I_{OFF} circuitry disables the output preventing damaging current backflow when the device is powered down. The gate performs the positive Boolean function:

$$Y = \overline{A}$$

Pin Assignments

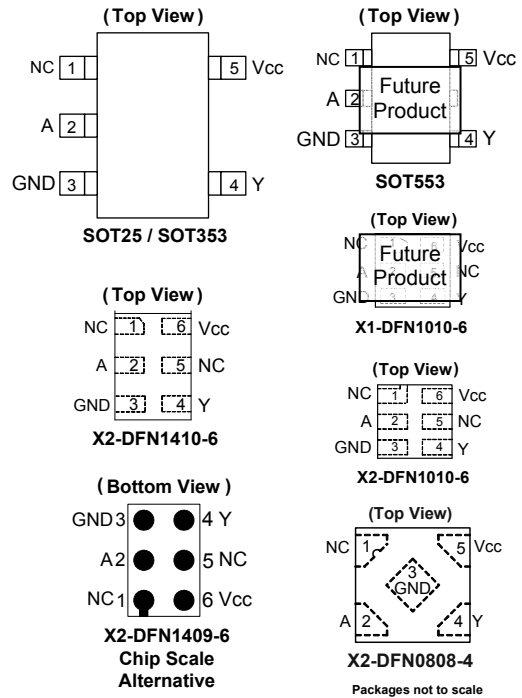

Features

- Wide Supply Voltage Range from 1.65V to 5.5V
- ± 24mA Output Drive at 3.3V
- CMOS low power consumption
- IOFF Supports Partial-Power-Down Mode Operation
- Inputs accept up to 5.5V
- ESD Protection Exceeds JESD 22
 - 200-V Machine Model (A115)
 - 2000-V Human Body Model (A114)
- Latch-Up Exceeds 100mA per JESD 78, Class I
- Range of Package Options
- **Totally Lead-Free & Fully RoHS Compliant (Notes 1 & 2)**
- **Halogen and Antimony Free. "Green" Device (Note 3)**

Applications

- Voltage Level Shifting
- General Purpose Logic
- Power Down Signal Isolation
- Wide array of products such as:
 - PCs, networking, notebooks, netbooks, PDAs
 - Computer peripherals, hard drives, CD/DVD ROM
 - TV, DVD, DVR, set top box
 - Cell Phones, Personal Navigation / GPS
 - MP3 players, Cameras, Video Recorders

Notes: 1. No purposely added lead. Fully EU Directive 2002/95/EC (RoHS) & 2011/65/EU (RoHS 2) compliant.
 2. See <http://www.diodes.com> for more information about Diodes Incorporated's definitions of Halogen- and Antimony-free, "Green" and Lead-free.
 3. Halogen- and Antimony-free "Green" products are defined as those which contain <900ppm bromine, <900ppm chlorine (<1500ppm total Br + Cl) and < 1000 ppm antimony compounds.

Ordering Information

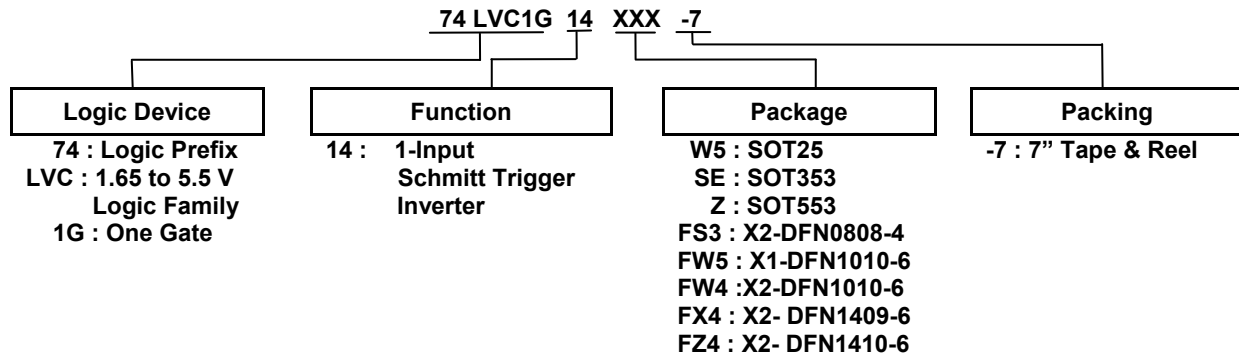

Device	Package Code	Package (Notes 4,5)	Package Size	7" Tape and Reel	
				Quantity	Part Number Suffix
74LVC1G14W5-7	W5	SOT25	3.0mm X 2.8mm X 1.2mm 0.95mm lead pitch	3000/Tape & Reel	-7
74LVC1G14SE-7	SE	SOT353	2.0mm X 2.0mm X 1.1mm 0.65mm lead pitch	3000/Tape & Reel	-7
74LVC1G14Z-7 Future Product	Z	SOT553 Future Product	1.6mm X 1.6 mm X 0.62mm 0.5mm lead pitch	4000/Tape & Reel	-7
74LVC1G14FS3-7	FS3	X2-DFN0808-4	0.9mm X 0.9 mm X 0.35mm 0.5mm pad pitch (diamond)	5000/Tape & Reel	-7
74LVC1G14FW5-7 (Future Product)	FW5	X1-DFN1010-6 (Future Product)	1.0mm X 1.0mm X 0.5mm 0.35mm pad pitch	5000/Tape & Reel	-7
74LVC1G14FW4-7	FW4	X2-DFN1010-6	1.0mm X 1.0mm X 0.4mm 0.35mm pad pitch	5000/Tape & Reel	-7
74LVC1G14FX4-7	FX4	X2-DFN1409-6 (Chip scale alternative)	1.4mm X 0.9mm X 0.4mm 0.5mm pad pitch	5000/Tape & Reel	-7
74LVC1G14FZ4-7	FZ4	X2-DFN1410-6	1.4mm X 1.0mm X 0.4mm 0.5mm pad pitch	5000/Tape & Reel	-7

Notes: 4. Pad layout as shown on Diodes Inc. suggested pad layout document AP02001, which can be found on our website at <http://www.diodes.com/datasheets/ap02001.pdf>
 5. The taping orientation is located on our website at <http://www.diodes.com/datasheets/ap02007.pdf>

Pin Descriptions

Pin Name	Description
A	Data Input
GND	Ground
Y	Data Output
V _{CC}	Supply Voltage

Logic Diagram

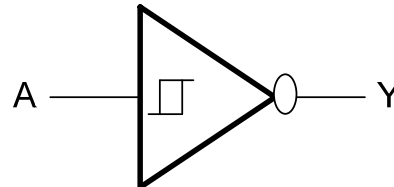

Function Table

Inputs	Output
A	Y
H	L
L	H

Absolute Maximum Ratings (Notes 6, 7)

Symbol	Description	Rating	Unit
ESD HBM	Human Body Model ESD Protection	2	kV
ESD MM	Machine Model ESD Protection	200	V
V _{CC}	Supply Voltage Range	-0.5 to 6.5	V
V _I	Input Voltage Range	-0.5 to 6.5	V
V _O	Voltage Applied to Output in High Impedance or I _{OFF} State	-0.5 to 6.5	V
V _O	Voltage Applied to Output in High or Low State	-0.5 to V _{CC} +0.5	V
I _{IK}	Input Clamp Current V _I < 0	-50	mA
I _{OK}	Output Clamp Current	-50	mA
I _O	Continuous Output Current	±50	mA
I _{CC} , I _{GND}	Continuous Current Through V _{CC} or GND	±100	mA
T _J	Operating Junction Temperature	-40 to 150	°C
T _{STG}	Storage Temperature	-65 to 150	°C

- Notes:
- Stresses beyond the absolute maximum may result in immediate failure or reduced reliability. These are stress values and device operation should be within recommend values.
 - Forcing the maximum allowed voltage could cause a condition exceeding the maximum current or conversely forcing the maximum current could cause a condition exceeding the maximum voltage. The ratings of both current and voltage must be maintained within the controlled range..

Recommended Operating Conditions (Note 8)

Symbol	Parameter	Min	Max	Unit	
V _{CC}	Operating Voltage	Operating	1.65	5.5	V
		Data retention only	1.5	—	V
V _I	Input Voltage	0	5.5	V	
V _O	Output Voltage	0	V _{CC}	V	
I _{OH}	High-Level Output Current	V _{CC} = 1.65V	—	-4	mA
		V _{CC} = 2.3V	—	-8	
		V _{CC} = 2.7V	—	-12	
		V _{CC} = 3V	—	-16	
		V _{CC} = 4.5V	—	-24	
I _{OL}	Low-Level Output Current	V _{CC} = 1.65V	—	4	mA
		V _{CC} = 2.3V	—	8	
		V _{CC} = 2.7V	—	12	
		V _{CC} = 3V	—	16	
		V _{CC} = 4.5V	—	24	
T _A	Operating Free-Air Temperature	—	-40	+125	°C

- Notes: 8. Unused inputs should be held at V_{CC} or Ground.

Electrical Characteristics
 $T_A = -40^{\circ}\text{C}$ to $+85^{\circ}\text{C}$ (All typical values are at $V_{CC} = 3.3\text{V}$, $T_A = +25^{\circ}\text{C}$)

Symbol	Parameter	Test Conditions	V_{CC}	Min	Typ.	Max	Unit
V_{T+}	Positive-Going Input Threshold Voltage	—	1.65V	0.70	—	1.20	—
		—	2.3V	1.11	—	1.60	—
		—	3V	1.50	—	2.00	—
		—	4.5V	2.16	—	2.74	—
		—	5.5V	2.61	—	3.33	—
V_{T-}	Negative- Going Input Threshold Voltage	—	1.65V	0.30	—	0.72	—
		—	2.3V	0.58	—	1.00	—
		—	3V	0.80	—	1.30	—
		—	4.5V	1.21	—	1.95	—
		—	5.5V	1.45	—	2.35	—
ΔV_T	Hysteresis ($V_{T+} - V_{T-}$)	—	1.65V	0.30	—	0.62	—
		—	2.3V	0.40	—	0.80	—
		—	3V	0.35	—	1.00	—
		—	4.5V	0.55	—	1.10	—
		—	5.5V	0.60	—	1.20	—
V_{OH}	High Level Output Voltage	$I_{OH} = -100\mu\text{A}$	1.65V to 5.5V	$V_{CC} - 0.1$	—	—	V
		$I_{OH} = -4\text{mA}$	1.65V	1.2	—	—	
		$I_{OH} = -8\text{mA}$	2.3V	1.9	—	—	
		$I_{OH} = -12\text{mA}$	2.7V	2.2	—	—	
		$I_{OH} = -16\text{mA}$	3V	2.4	—	—	
		$I_{OH} = -24\text{mA}$		2.3	—	—	
		$I_{OH} = -32\text{mA}$	4.5V	3.8	—	—	
V_{OL}	Low-Level Output Voltage	$I_{OL} = 100\mu\text{A}$	1.65V to 5.5V	—	—	0.1	V
		$I_{OL} = 4\text{mA}$	1.65V	—	—	0.45	
		$I_{OL} = 8\text{mA}$	2.3V	—	—	0.3	
		$I_{OL} = 12\text{mA}$	2.7V	—	—	0.4	
		$I_{OL} = 16\text{mA}$	3V	—	—	0.4	
		$I_{OL} = 24\text{mA}$		—	—	0.55	
		$I_{OL} = 32\text{mA}$	4.5	—	—	0.55	
I_I	Input Current	$V_I = 5.5\text{V}$ or GND	0 to 5.5V	—	—	± 5	μA
I_{OFF}	Power Down Leakage Current	V_I or $V_O = 5.5\text{V}$	0	—	—	± 10	μA
I_{CC}	Supply Current	$V_I = 5.5\text{V}$ of GND $I_O = 0$	1.65V to 5.5V	—	—	10	μA
ΔI_{CC}	Additional Supply Current	Input at $V_{CC} - 0.6\text{V}$	3V to 5.5V	—	—	500	μA

Electrical Characteristics $T_A = -40^{\circ}\text{C}$ to $+125^{\circ}\text{C}$ (All typical values are at $V_{CC} = 3.3\text{V}$, $T_A = +25^{\circ}\text{C}$)

Symbol	Parameter	Test Conditions	V_{CC}	Min	Typ.	Max	Unit
V_{T+}	Positive- Going Input Threshold Voltage	—	1.65V	0.70	—	1.20	—
		—	2.3V	1.11	—	1.60	—
		—	3V	1.50	—	2.00	—
		—	4.5V	2.16	—	2.74	—
		—	5.5V	2.61	—	3.33	—
V_{T-}	Negative- Going Input Threshold Voltage	—	1.65V	0.30	—	0.75	—
		—	2.3V	0.58	—	1.03	—
		—	3V	0.80	—	1.33	—
		—	4.5V	1.21	—	1.95	—
		—	5.5V	1.45	—	2.35	—
ΔV_T	Hysteresis ($V_{T+} - V_{T-}$)	—	1.65V	0.30	—	0.62	—
		—	2.3V	0.37	—	0.80	—
		—	3V	0.32	—	1.00	—
		—	4.5V	0.50	—	1.20	—
		—	5.5V	0.55	—	1.40	—
V_{OH}	High Level Output Voltage	$I_{OH} = -100\mu\text{A}$	1.65V to 5.5V	$V_{CC} - 0.1$	—	—	V
		$I_{OH} = -4\text{mA}$	1.65V	0.95	—	—	
		$I_{OH} = -8\text{mA}$	2.3V	1.7	—	—	
		$I_{OH} = -12\text{mA}$	2.7V	1.9	—	—	
		$I_{OH} = -16\text{mA}$	3V	1.9	—	—	
		$I_{OH} = -24\text{mA}$		2.0	—	—	
		$I_{OH} = -32\text{mA}$	4.5V	3.4	—	—	
V_{OL}	Low-Level Output Voltage	$I_{OL} = 100\mu\text{A}$	1.65V to 5.5V	—	—	0.1	V
		$I_{OL} = 4\text{mA}$	1.65V	—	—	0.7	
		$I_{OL} = 8\text{mA}$	2.3V	—	—	0.45	
		$I_{OL} = 12\text{mA}$	2.7V	—	—	0.6	
		$I_{OL} = 16\text{mA}$	3V	—	—	0.6	
		$I_{OL} = 24\text{mA}$		—	—	0.8	
		$I_{OL} = 32\text{mA}$	4.5V	—	—	0.8	
I_I	Input Current	$V_I = 5.5\text{V}$ or GND	0 to 5.5V	—	—	± 100	μA
I_{OFF}	Power Down Leakage Current	V_I or $V_O = 5.5\text{V}$	0	—	—	± 200	μA
I_{CC}	Supply Current	$V_I = 5.5\text{V}$ of GND $I_O = 0$	1.65V to 5.5V	—	—	200	μA
ΔI_{CC}	Additional Supply Current	Input at $V_{CC} - 0.6\text{V}$	3V to 5.5V	—	—	5000	μA

Package Characteristics (All typical values are at $V_{CC} = 3.3V$, $T_A = +25^\circ C$)

Symbol	Parameter	Test Conditions	V_{CC}	Min	Typ.	Max	Unit
θ_{JA}	Thermal Resistance Junction-to-Ambient	SOT25	(Note 9)	—	204	—	$^\circ C/W$
		SOT353		—	371	—	
		SOT553		—	231	—	
		X2-DFN0808-4		—	400	—	
		X1-DFN1010-6		—	435	—	
		X2-DFN1010-6		—	445	—	
		X2-DFN1409-6		—	470	—	
		X2-DFN1410-6		—	460	—	
θ_{JC}	Thermal Resistance Junction-to-Case	SOT25	(Note 9)	—	52	—	$^\circ C/W$
		SOT353		—	143	—	
		SOT553		—	105	—	
		X2-DFN0808-4		—	225	—	
		X1-DFN1010-6		—	250	—	
		X2-DFN1010-6		—	250	—	
		X2-DFN1409-6		—	275	—	
		X2-DFN1410-6		—	265	—	

Note: 9. Test condition for each of the 8 package types: Device mounted on FR-4 substrate PC board, 2oz copper, with minimum recommended pad layout.

Switching Characteristics

$T_A = -40^\circ C$ to $+85^\circ C$, $C_L = 15pF$ as noted (see Figure 1)

Parameter	From Input	To Output	$V_{CC} = 1.8V \pm 0.15V$		$V_{CC} = 2.5V \pm 0.2V$		$V_{CC} = 3.3V \pm 0.3V$		$V_{CC} = 5V \pm 0.5V$		Unit
			Min	Max	Min	Max	Min	Max	Min	Max	
t_{pd}	A	Y	1.0	9.9	0.7	5.5	0.7	4.6	0.7	4.4	ns

$T_A = -40^\circ C$ to $+85^\circ C$, $C_L = 30$ or $50pF$ as noted (see Figure 2)

Parameter	From Input	To Output	$V_{CC} = 1.8V \pm 0.15V$		$V_{CC} = 2.5V \pm 0.2V$		$V_{CC} = 3.3V \pm 0.3V$		$V_{CC} = 5V \pm 0.5V$		Unit
			Min	Max	Min	Max	Min	Max	Min	Max	
t_{pd}	A	Y	1.0	11	0.7	6.5	0.7	5.5	0.7	5	ns

$T_A = -40^\circ C$ to $+125^\circ C$, $C_L = 15pF$ as noted (see Figure 1)

Parameter	From Input	To Output	$V_{CC} = 1.8V \pm 0.15V$		$V_{CC} = 2.5V \pm 0.2V$		$V_{CC} = 3.3V \pm 0.3V$		$V_{CC} = 5V \pm 0.5V$		Unit
			Min	Max	Min	Max	Min	Max	Min	Max	
t_{pd}	A	Y	1.0	12.5	0.7	7.5	0.7	6.5	0.7	5.5	ns

$T_A = -40^\circ C$ to $+125^\circ C$, $C_L = 30$ or $50pF$ as noted (see Figure 2)

Parameter	From Input	To Output	$V_{CC} = 1.8V \pm 0.15V$		$V_{CC} = 2.5V \pm 0.2V$		$V_{CC} = 3.3V \pm 0.3V$		$V_{CC} = 5V \pm 0.5V$		Unit
			Min	Max	Min	Max	Min	Max	Min	Max	
t_{pd}	A	Y	1.0	14.0	0.7	8.5	0.7	7.0	0.7	6.5	ns

Operating Characteristics

T_A = +25°C

Parameter		Test Conditions	V _{CC} = 1.8V	V _{CC} = 2.5V	V _{CC} = 3.3V	V _{CC} = 5V	Unit
			Typ.	Typ.	Typ.	Typ.	
C _{pd}	Power Dissipation Capacitance	f = 10 MHz	20	21	22	25	pF

Parameter Measurement Information

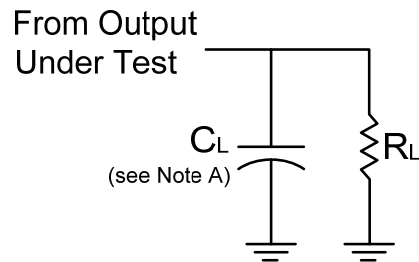

V _{CC}	Inputs		V _M	C _L	R _L
	V _I	t _r /t _f			
1.8V±0.15V	V _{CC}	≤2ns	V _{CC} /2	15pF	1MΩ
2.5V±0.2V	V _{CC}	≤2ns	V _{CC} /2	15pF	1MΩ
3.3V±0.3V	3V	≤2.5ns	1.5V	15pF	1MΩ
5V±0.5V	V _{CC}	≤2.5ns	V _{CC} /2	15pF	1MΩ

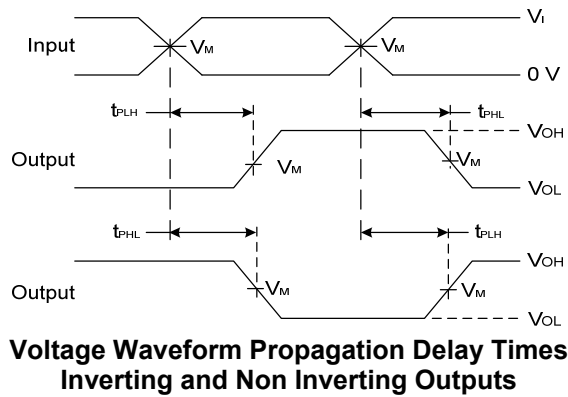
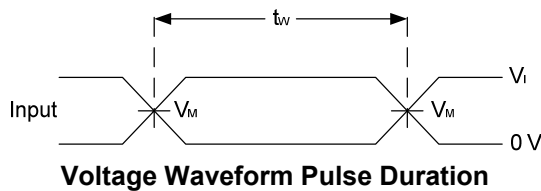
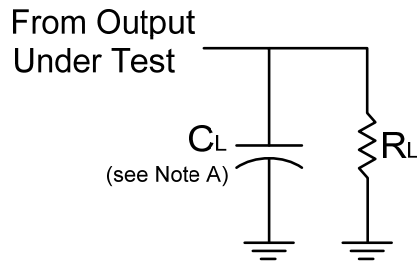

Figure 1. Load Circuit and Voltage Waveforms

- Notes:
- A. Includes test lead and test apparatus capacitance.
 - B. All pulses are supplied at pulse repetition rate ≤ 10MHz.
 - C. Inputs are measured separately one transition per measurement.
 - D. t_{PLH} and t_{PHL} are the same as t_{PD}.

Parameter Measurement Information (Cont.)



V_{CC}	Inputs		V_M	C_L	R_L
	V_I	t_r/t_f			
$1.8V \pm 0.15V$	V_{CC}	$\leq 2ns$	$V_{CC}/2$	30pF	1k Ω
$2.5V \pm 0.2V$	V_{CC}	$\leq 2ns$	$V_{CC}/2$	30pF	500 Ω
$3.3V \pm 0.3V$	3V	$\leq 2.5ns$	1.5V	50pF	500 Ω
$5V \pm 0.5V$	V_{CC}	$\leq 2.5ns$	$V_{CC}/2$	50pF	500 Ω

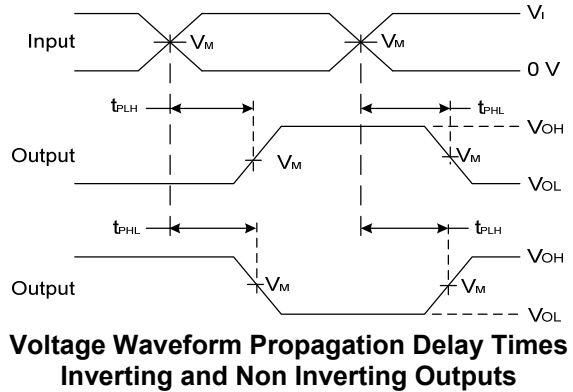
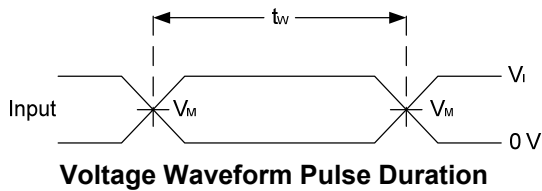
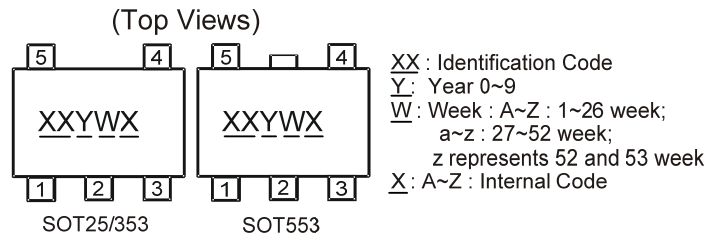

Figure 2. Load Circuit and Voltage Waveforms

- Notes:
- A. Includes test lead and test apparatus capacitance.
 - B. All pulses are supplied at pulse repetition rate $\leq 10MHz$.
 - C. Inputs are measured separately one transition per measurement.
 - D. t_{PLH} and t_{PHL} are the same as t_{PD} .

Marking Information

(1) SOT25, SOT353 and SOT553



Part Number	Package	Identification Code
74LVC1G14W5-7	SOT25	UP
74LVC1G14SE-7	SOT353	UP
74LVC1G14Z-7	SOT553	UP

(2) DFN packages

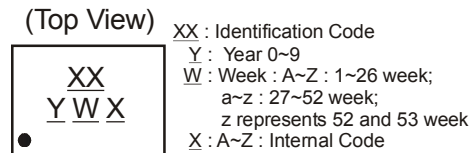

Part Number	Package	Identification Code
74LVC1G14FS3-7	X2-DFN0808-4	WP
74LVC1G14FW5-7	X1-DFN1010-6	V8
74LVC1G14FW4-7	X2-DFN1010-6	UP
74LVC1G14FX4-7	X2-DFN1409-6	MG
74LVC1G14FZ4-7	X2-DFN1410-6	UP

Package Outline Dimensions (All Dimensions in mm)

(1) Package Type: SOT25

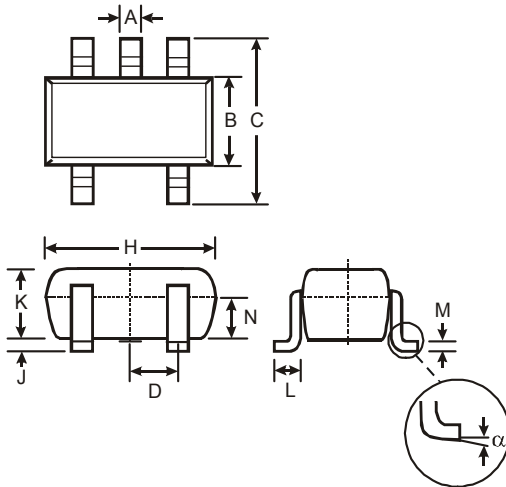

SOT25			
Dim	Min	Max	Typ
A	0.35	0.50	0.38
B	1.50	1.70	1.60
C	2.70	3.00	2.80
D	—	—	0.95
H	2.90	3.10	3.00
J	0.013	0.10	0.05
K	1.00	1.30	1.10
L	0.35	0.55	0.40
M	0.10	0.20	0.15
N	0.70	0.80	0.75
α	0°	8°	—
All Dimensions in mm			

(2) Package Type: SOT353

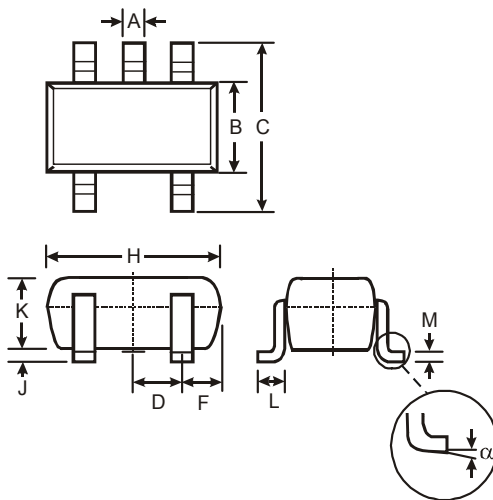

SOT353		
Dim	Min	Max
A	0.10	0.30
B	1.15	1.35
C	2.00	2.20
D	0.65 Typ	
F	0.40	0.45
H	1.80	2.20
J	0	0.10
K	0.90	1.00
L	0.25	0.40
M	0.10	0.22
α	0°	8°
All Dimensions in mm		

(3) Package Type: SOT553

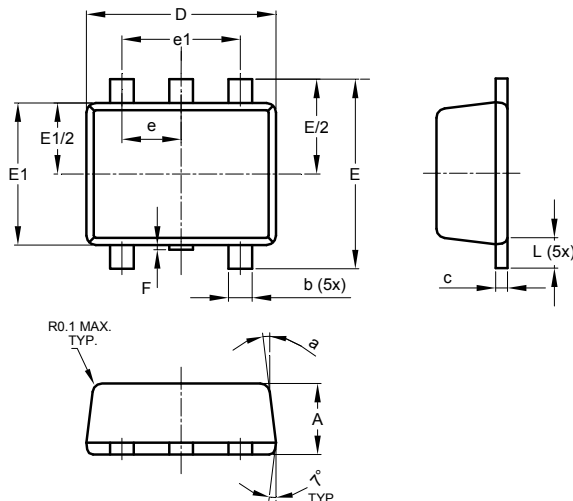

SOT553			
Dim	Min	Max	Typ
A	0.55	0.62	0.60
b	0.15	0.30	0.20
c	0.10	0.18	0.15
D	1.50	1.70	1.60
E	1.55	1.70	1.60
E1	1.10	1.25	1.20
e	0.50 BSC		
e1	1.00 BSC		
F	0.00	0.10	—
L	0.10	0.30	0.20
a	6°	8°	7°
All Dimensions in mm			

Package Outline Dimensions (cont.)

(4) Package Type X2-DFN0808-4

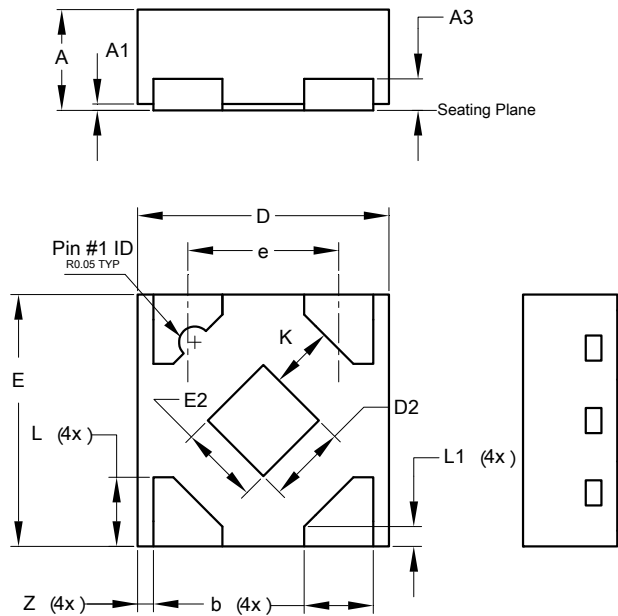

X2-DFN0808-4			
Dim	Min	Max	Typ
A	0.25	0.35	0.30
A1	0	0.04	0.02
A3	-	-	0.13
b	0.17	0.27	0.22
D	0.75	0.85	0.80
D2	0.15	0.35	0.25
E	0.75	0.85	0.80
E2	0.15	0.35	0.25
e	-	-	0.48
K	0.20	-	-
L	0.17	0.27	0.22
L1	0.02	0.12	0.07
Z	-	-	0.05
All Dimensions in mm			

(5) Package Type: X1-DFN1010-6

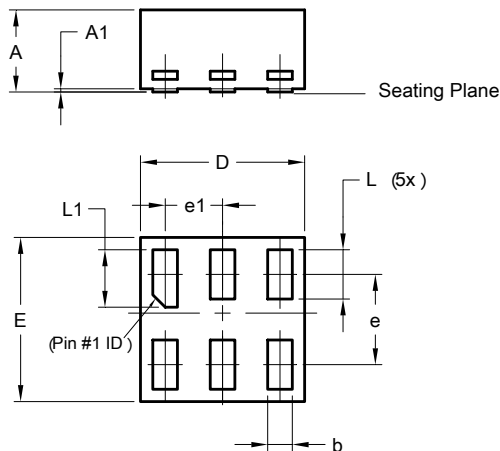

X1-DFN1010-6			
Dim	Min	Max	Typ
A	-	0.50	0.39
A1	-	0.04	-
b	0.12	0.20	0.15
D	0.95	1.050	1.00
E	0.95	1.050	1.00
e	0.55 BSC		
e1	0.35 BSC		
L	0.27	0.35	0.30
L1	0.32	0.40	0.35
All Dimensions in mm			

Package Outline Dimensions (cont.)

(6) Package Type X2-DFN1010-6

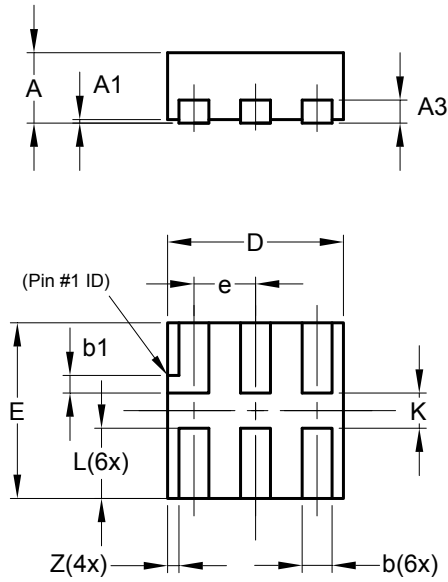

X2-DFN1010-6			
Dim	Min	Max	Typ
A	—	0.40	0.39
A1	0.00	0.05	0.02
A3	—	—	0.13
b	0.14	0.20	0.17
b1	0.05	0.15	0.10
D	0.95	1.05	1.00
E	0.95	1.05	1.00
e	—	—	0.35
L	0.35	0.45	0.40
K	0.15	—	—
Z	—	—	0.065
All Dimensions in mm			

(7) Package Type: X2-DFN1409-6 6 CHIP SCALE ALTERNATIVE

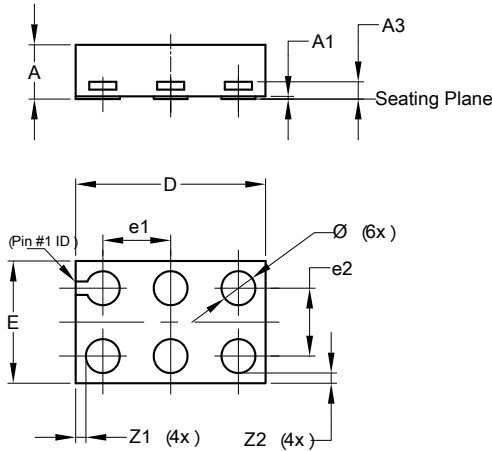

X2-DFN1409-6			
Dim	Min	Max	Typ
A	-	0.40	0.39
A1	0	0.05	0.02
A3	-	-	0.13
Ø	0.20	0.30	0.25
D	1.35	1.45	1.40
E	0.85	0.95	0.90
e1	-	-	0.50
e2	-	-	0.50
Z1	-	-	0.075
Z2	-	-	0.075
All Dimensions in mm			

(8) Package Type: X2-DFN1410-6

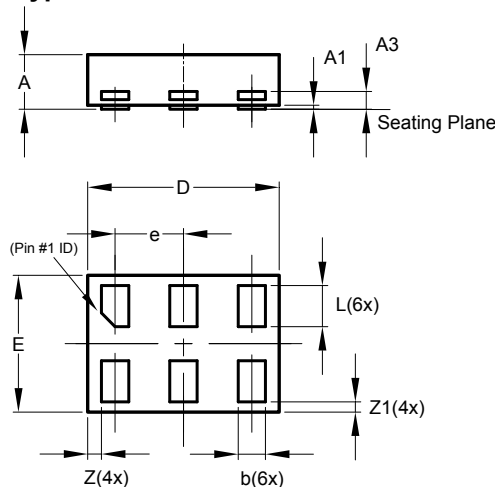

X2-DFN1410-6			
Dim	Min	Max	Typ
A	—	0.40	0.39
A1	0.00	0.05	0.02
A3	—	—	0.13
b	0.15	0.25	0.20
D	1.35	1.45	1.40
E	0.95	1.05	1.00
e	—	—	0.50
L	0.25	0.35	0.30
Z	—	—	0.10
Z1	0.045	0.105	0.075
All Dimensions in mm			

Suggested Pad Layout

(1) Package Type: SOT25

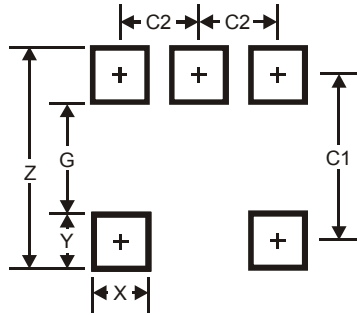

Dimensions	Value (in mm)
Z	3.20
G	1.60
X	0.55
Y	0.80
C1	2.40
C2	0.95

(2) Package Type: SOT353

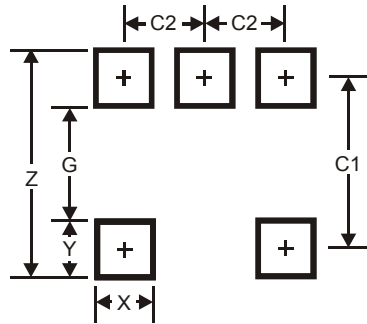

Dimensions	Value (in mm)
Z	2.5
G	1.3
X	0.42
Y	0.6
C1	1.9
C2	0.65

(3) Package Type: SOT553

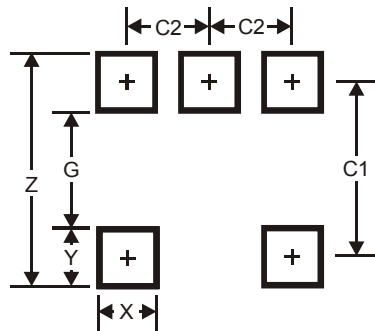

Dimensions	Value (in mm)
Z	2.2
G	1.2
X	0.375
Y	0.5
C1	1.7
C2	0.5

Suggested Pad Layout (cont.)

(4) Package Type X2-DFN0808-4

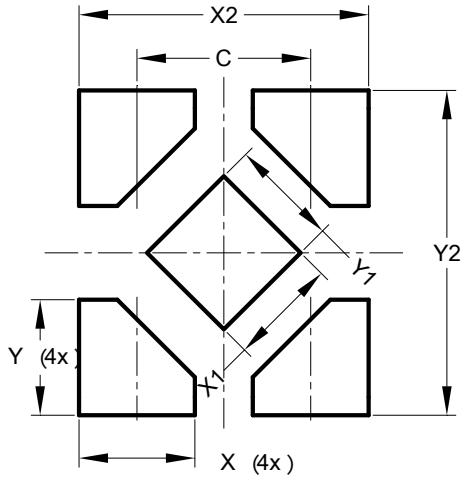

Dimensions	Value (in mm)
C	0.480
X	0.320
X1	0.300
X2	0.800
Y	0.320
Y1	0.300
Y2	0.900

(5) Package Type X1-DFN1010-6

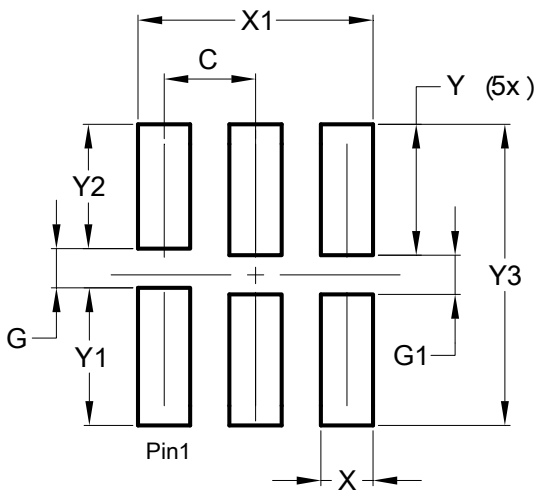

Dimensions	Value (in mm)
C	0.350
G	0.150
G1	0.150
X	0.200
X1	0.900
Y	0.500
Y1	0.525
Y2	0.475
Y3	1.150

Suggested Pad Layout (cont.)

(6) (Package Type X2-DFN1010-6)

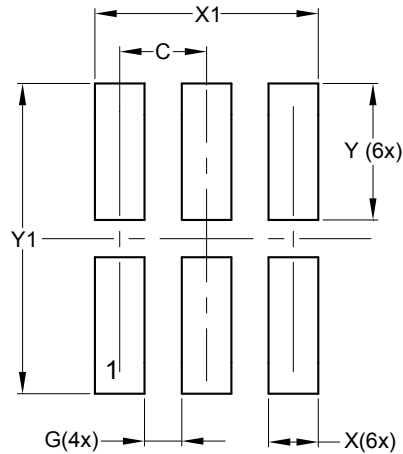

Dimensions	Value (in mm)
C	0.350
G	0.150
X	0.200
X1	0.900
Y	0.550
Y1	1.250

(7) Package Type: X2-DFN1409-6

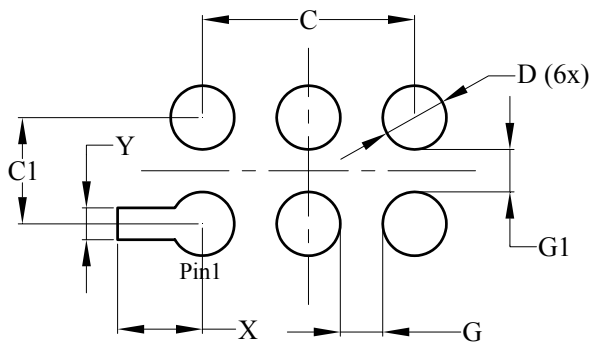

Dimensions	Value (in mm)
C	1.000
C1	0.500
D	0.300
G	0.200
G1	0.200
X	0.400
Y	0.150

(8) Package Type: X2-DFN1410-6

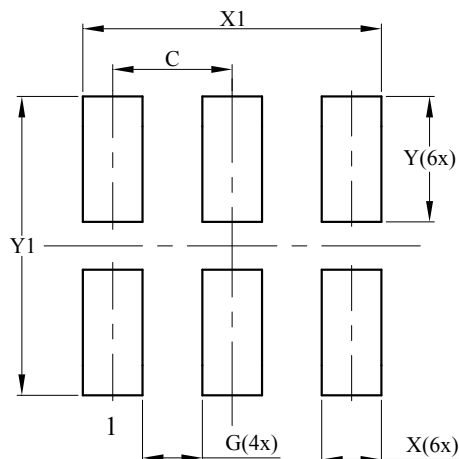

Dimensions	Value (in mm)
C	0.500
G	0.250
X	0.250
X1	1.250
Y	0.525
Y1	1.250

IMPORTANT NOTICE

DIODES INCORPORATED MAKES NO WARRANTY OF ANY KIND, EXPRESS OR IMPLIED, WITH REGARDS TO THIS DOCUMENT, INCLUDING, BUT NOT LIMITED TO, THE IMPLIED WARRANTIES OF MERCHANTABILITY AND FITNESS FOR A PARTICULAR PURPOSE (AND THEIR EQUIVALENTS UNDER THE LAWS OF ANY JURISDICTION).

Diodes Incorporated and its subsidiaries reserve the right to make modifications, enhancements, improvements, corrections or other changes without further notice to this document and any product described herein. Diodes Incorporated does not assume any liability arising out of the application or use of this document or any product described herein; neither does Diodes Incorporated convey any license under its patent or trademark rights, nor the rights of others. Any Customer or user of this document or products described herein in such applications shall assume all risks of such use and will agree to hold Diodes Incorporated and all the companies whose products are represented on Diodes Incorporated website, harmless against all damages.

Diodes Incorporated does not warrant or accept any liability whatsoever in respect of any products purchased through unauthorized sales channel.

Should Customers purchase or use Diodes Incorporated products for any unintended or unauthorized application, Customers shall indemnify and hold Diodes Incorporated and its representatives harmless against all claims, damages, expenses, and attorney fees arising out of, directly or indirectly, any claim of personal injury or death associated with such unintended or unauthorized application.

Products described herein may be covered by one or more United States, international or foreign patents pending. Product names and markings noted herein may also be covered by one or more United States, international or foreign trademarks.

This document is written in English but may be translated into multiple languages for reference. Only the English version of this document is the final and determinative format released by Diodes Incorporated.

LIFE SUPPORT

Diodes Incorporated products are specifically not authorized for use as critical components in life support devices or systems without the express written approval of the Chief Executive Officer of Diodes Incorporated. As used herein:

A. Life support devices or systems are devices or systems which:

1. are intended to implant into the body, or
2. support or sustain life and whose failure to perform when properly used in accordance with instructions for use provided in the labeling can be reasonably expected to result in significant injury to the user.

B. A critical component is any component in a life support device or system whose failure to perform can be reasonably expected to cause the failure of the life support device or to affect its safety or effectiveness.

Customers represent that they have all necessary expertise in the safety and regulatory ramifications of their life support devices or systems, and acknowledge and agree that they are solely responsible for all legal, regulatory and safety-related requirements concerning their products and any use of Diodes Incorporated products in such safety-critical, life support devices or systems, notwithstanding any devices- or systems-related information or support that may be provided by Diodes Incorporated. Further, Customers must fully indemnify Diodes Incorporated and its representatives against any damages arising out of the use of Diodes Incorporated products in such safety-critical, life support devices or systems.

Copyright © 2014, Diodes Incorporated

www.diodes.com



Компания «ЭлектроПласт» предлагает заключение долгосрочных отношений при поставках импортных электронных компонентов на взаимовыгодных условиях!

Наши преимущества:

- Оперативные поставки широкого спектра электронных компонентов отечественного и импортного производства напрямую от производителей и с крупнейших мировых складов;
- Поставка более 17-ти миллионов наименований электронных компонентов;
- Поставка сложных, дефицитных, либо снятых с производства позиций;
- Оперативные сроки поставки под заказ (от 5 рабочих дней);
- Экспресс доставка в любую точку России;
- Техническая поддержка проекта, помощь в подборе аналогов, поставка прототипов;
- Система менеджмента качества сертифицирована по Международному стандарту ISO 9001;
- Лицензия ФСБ на осуществление работ с использованием сведений, составляющих государственную тайну;
- Поставка специализированных компонентов (Xilinx, Altera, Analog Devices, Intersil, Interpoint, Microsemi, Aeroflex, Peregrine, Syfer, Eurofarad, Texas Instrument, Miteq, Cobham, E2V, MA-COM, Hittite, Mini-Circuits, General Dynamics и др.);

Помимо этого, одним из направлений компании «ЭлектроПласт» является направление «Источники питания». Мы предлагаем Вам помощь Конструкторского отдела:

- Подбор оптимального решения, техническое обоснование при выборе компонента;
- Подбор аналогов;
- Консультации по применению компонента;
- Поставка образцов и прототипов;
- Техническая поддержка проекта;
- Защита от снятия компонента с производства.



Как с нами связаться

Телефон: 8 (812) 309 58 32 (многоканальный)

Факс: 8 (812) 320-02-42

Электронная почта: org@eplast1.ru

Адрес: 198099, г. Санкт-Петербург, ул. Калинина, дом 2, корпус 4, литера А.