



The SST25WF512 / SST25WF010 / SST25WF020 / SST25WF040 are members of the Serial Flash 25 Series family and feature a four-wire, SPI-compatible interface that allows for a low pin-count package which occupies less board space and ultimately lowers total system costs. SPI serial flash memory is manufactured with SST proprietary, high performance CMOS SuperFlash technology. The split-gate cell design and thick-oxide tunneling injector attain better reliability and manufacturability compared with alternate approaches.

Features

- **Single Voltage Read and Write Operations**
 - 1.65-1.95V
- **Serial Interface Architecture**
 - SPI Compatible: Mode 0 and Mode 3
- **High Speed Clock Frequency**
 - 40MHz
- **Superior Reliability**
 - Endurance: 100,000 Cycles
 - Greater than 100 years Data Retention
- **Ultra-Low Power Consumption:**
 - Active Read Current: 2 mA (typical @ 20MHz)
 - Standby Current: 2 μ A (typical)
- **Flexible Erase Capability**
 - Uniform 4 KByte sectors
 - Uniform 32 KByte overlay blocks
 - Uniform 64 KByte overlay blocks (2 Mbit and 4 Mbit only)
- **Fast Erase and Byte-Program:**
 - Chip-Erase Time: 125 ms (typical)
 - Sector-/Block-Erase Time: 62ms (typical)
 - Byte-Program Time: 50 μ S (typical)
- **Auto Address Increment (AAI) Programming**
 - Decrease total chip programming time over Byte-Program operations
- **End-of-Write Detection**
 - Software polling the BUSY bit in Status Register
 - Busy Status readout on SO pin
- **Reset Pin (RST#) or Programmable Hold Pin (HOLD#) option**
 - Hardware Reset pin as default
 - Hold pin option to suspend a serial sequence without deselecting the device
- **Write Protection (WP#)**
 - Enables/Disables the Lock-Down function of the status register
- **Software Write Protection**
 - Write protection through Block-Protection bits in status register
- **Temperature Range**
 - Industrial: -40°C to +85°C
- **Packages Available**
 - 8-lead SOIC (150 mils)
 - 8-contact WSON (5mm x 6mm)
- **All devices are RoHS compliant**



A Microchip Technology Company

512 Kbit / 1 Mbit / 2 Mbit / 4 Mbit 1.8V SPI Serial Flash

SST25WF512 / SST25WF010 / SST25WF020 / SST25WF040

Data Sheet

Product Description

The SST25WF512, SST25WF010, SST25WF020, and SST25WF040 are members of the Serial Flash 25 Series family and feature a four-wire, SPI-compatible interface that allows for a low pin-count package which occupies less board space and ultimately lowers total system costs. SST25WF512/010/020/040 SPI serial flash memories are manufactured with SST proprietary, high-performance CMOS SuperFlash technology. The split-gate cell design and thick-oxide tunneling injector attain better reliability and manufacturability compared with alternate approaches.

The SST25WF512/010/020/040 devices significantly improve performance and reliability, while lowering power consumption. The devices write (Program or Erase) with a single power supply of 1.65-1.95V for SST25WF512/010/020/040. The total energy consumed is a function of the applied voltage, current, and time of application. Since for any given voltage range, the SuperFlash technology uses less current to program and has a shorter erase time, the total energy consumed during any Erase or Program operation is less than alternative flash memory technologies.

The SST25WF512/010/020/040 devices are offered in both 8-lead SOIC and an 8-contact WSON packages. See Figure 2 for the pin assignment.



Block Diagram

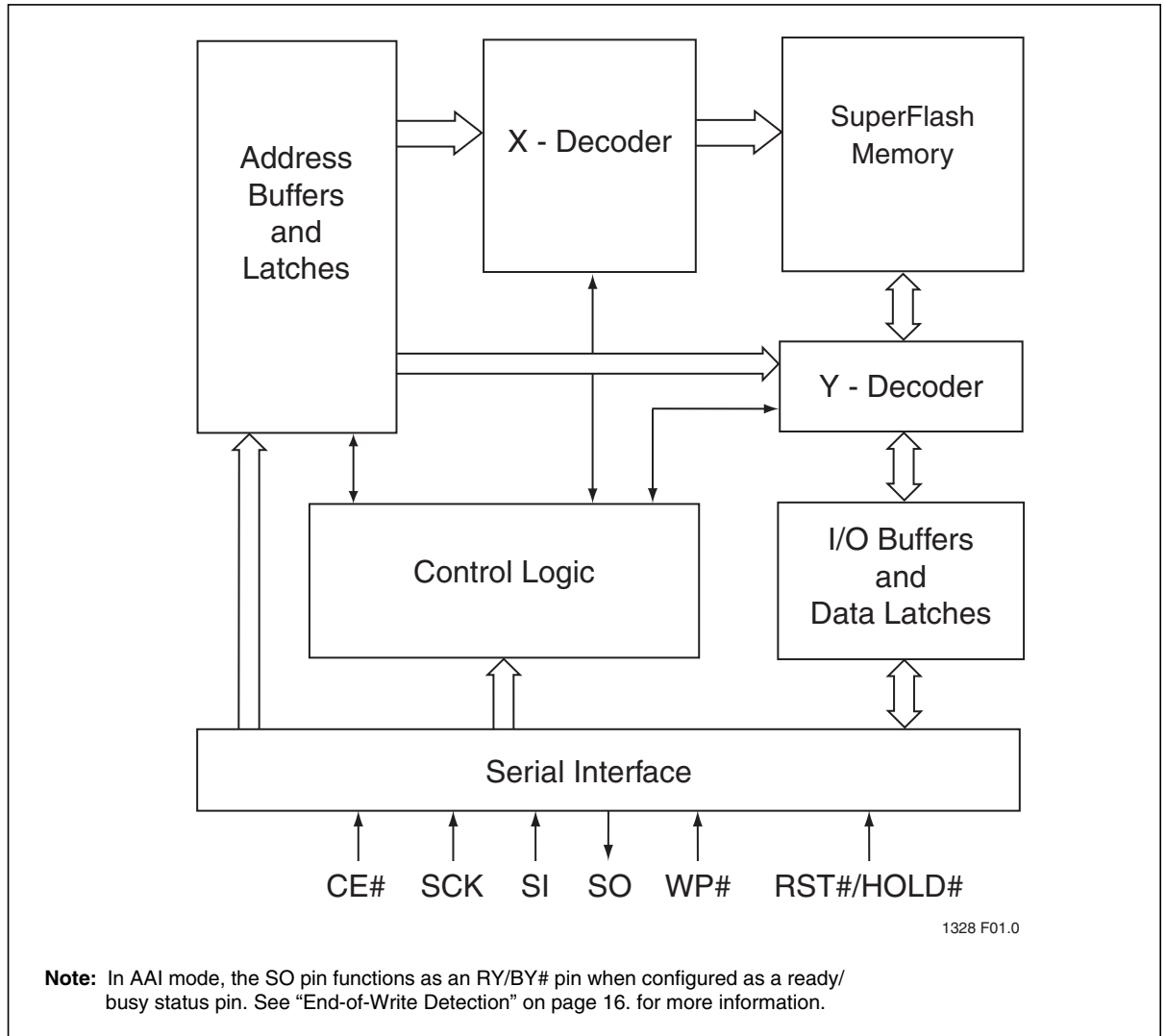

Figure 1: Functional Block Diagram



Pin Description

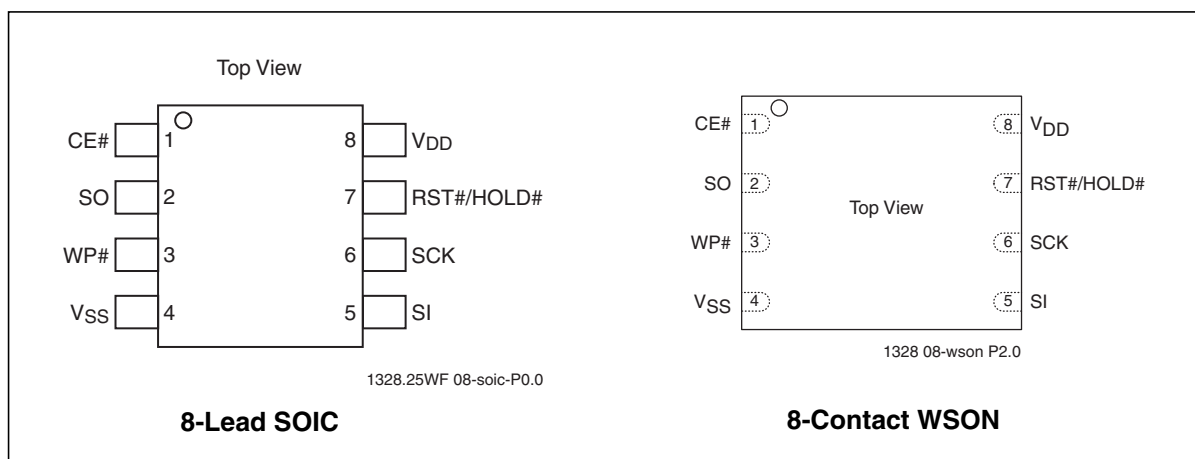

Figure 2: Pin Assignment for 8-Lead SOIC and 8-Contact WSON

Table 1: Pin Description

Symbol	Pin Name	Functions
SCK	Serial Clock	To provide the timing of the serial interface. Commands, addresses, or input data are latched on the rising edge of the clock input, while output data is shifted out on the falling edge of the clock input.
SI	Serial Data Input	To transfer commands, addresses, or data serially into the device. Inputs are latched on the rising edge of the serial clock.
SO	Serial Data Output	To transfer data serially out of the device. Data is shifted out on the falling edge of the serial clock. Flash busy status pin in AAI mode if SO is configured as a hardware RY/BY# pin. See “End-of-Write Detection” on page 16. for more information.
CE#	Chip Enable	The device is enabled by a high to low transition on CE#. CE# must remain low for the duration of any command sequence.
WP#	Write Protect	The Write Protect (WP#) pin is used to enable/disable BPL bit in the status register.
RST#/ HOLD#	Reset	To reset the operation of the device and the internal logic. The device powers on with RST# pin functionality as default.
	Hold	To temporarily stop serial communication with SPI Flash memory while device is selected. This is selected by an instruction sequence which is detailed in “Reset/Hold Mode” on page 6.
VDD	Power Supply	To provide power supply voltage: 1.65-1.95V for SST25WF512/010/020/040
VSS	Ground	

T1.0 25016



Memory Organization

The SST25WF512/010/020/040 SuperFlash memory arrays are organized in uniform 4 KByte with 16 KByte, 32 KByte, and 64 KByte (2 Mbit and 4 Mbit Only) overlay erasable blocks.

Device Operation

The SST25WF512/010/020/040 are accessed through the SPI (Serial Peripheral Interface) bus compatible protocol. The SPI bus consist of four control lines; Chip Enable (CE#) is used to select the device, and data is accessed through the Serial Data Input (SI), Serial Data Output (SO), and Serial Clock (SCK).

The SST25WF512/010/020/040 support both Mode 0 (0,0) and Mode 3 (1,1) of SPI bus operations. The difference between the two modes, as shown in Figure 3, is the state of the SCK signal when the bus master is in Stand-by mode and no data is being transferred. The SCK signal is low for Mode 0 and SCK signal is high for Mode 3. For both modes, the Serial Data In (SI) is sampled at the rising edge of the SCK clock signal and the Serial Data Output (SO) is driven after the falling edge of the SCK clock signal.

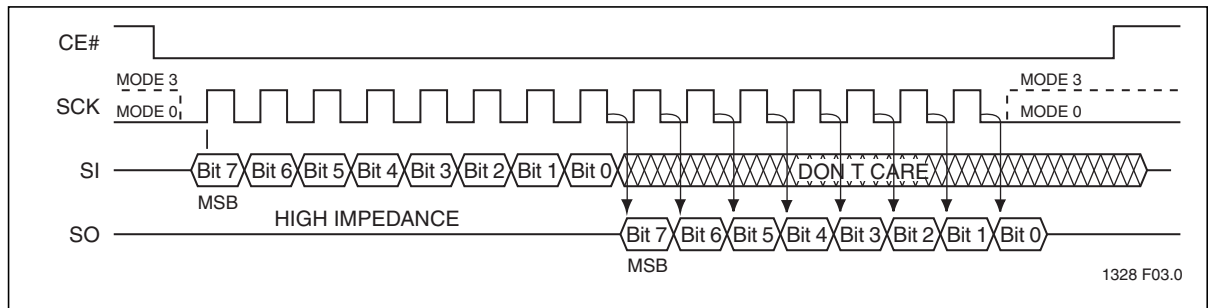

Figure 3: SPI Protocol



Reset/Hold Mode

The RST#/HOLD# pin provides either a hardware reset or a hold pin. From power-on, the RST#/HOLD# pin defaults as a hardware reset pin (RST#). The Hold mode for this pin is a user selected option where an Enable-Hold instruction enables the Hold mode. Once selected as a hold pin (HOLD#), the RST#/HOLD# pin will be configured as a HOLD# pin, and goes back to RST# pin only after a power-off and power-on sequence.

Reset

If the RST#/HOLD# pin is used as a reset pin, RST# pin provides a hardware method for resetting the device. Driving the RST# pin high puts the device in normal operating mode. The RST# pin must be driven low for a minimum of T_{RST} time to reset the device. The SO pin is in high impedance state while the device is in reset. A successful reset will reset the status register to its power-up state. See Table 4 for default power-up modes. A device reset during an active Program or Erase operation aborts the operation and data of the targeted address range may be corrupted or lost due to the aborted erase or program operation. The device exits AAI Programming Mode in progress and places the SO pin in high impedance state.

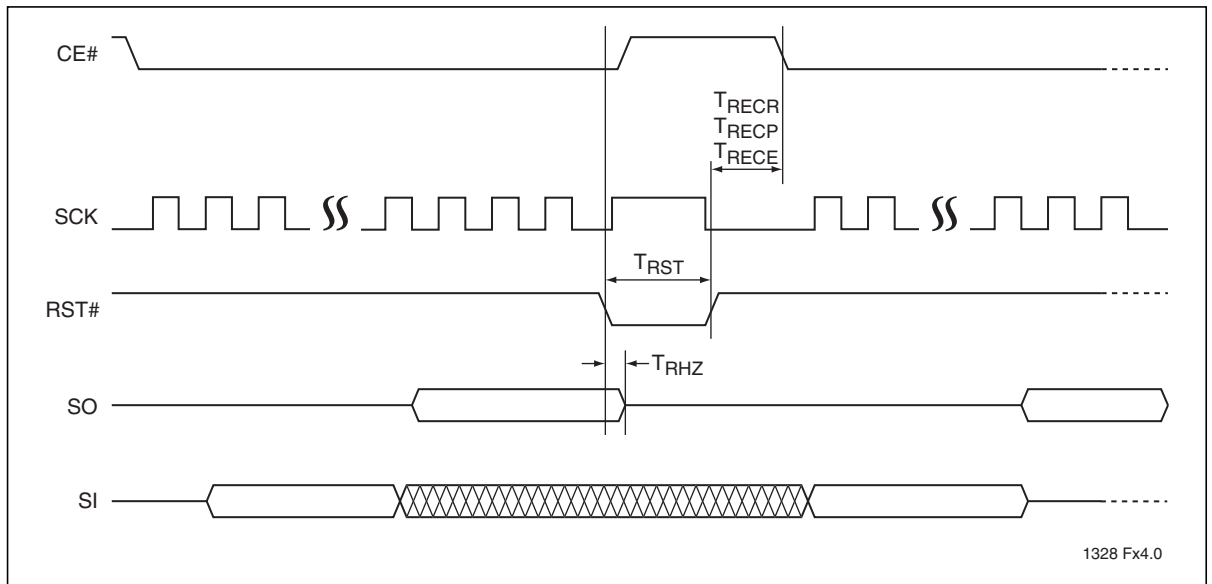

Figure 4: Reset Timing Diagram

Table 2: Reset Timing Parameters

Symbol	Parameter	Min	Max	Units
T_{RST}	Reset Pulse Width	100		ns
T_{RHZ}	Reset to High-Z Output		107	ns
T_{RECR}	Reset Recovery from Read		100	ns
T_{RECP}	Reset Recovery from Program		10	μ s
T_{RECE}	Reset Recovery from Erase		1	ms

T2.25016



Hold

The Hold operation enables the hold pin functionality of the RST#/HOLD# pin. Once set to hold pin mode, the RST#/HOLD# pin continues functioning as a hold pin until the device is powered off and then powered on. After a power-off and power-on, the pin functionality returns to a reset pin (RST#) mode. See “Enable-Hold (EHLD)” on page 22 for detailed timing of the Hold instruction.

In the hold mode, serial sequences underway with the SPI Flash memory are paused without resetting the clocking sequence. To activate the HOLD# mode, CE# must be in active low state. The HOLD# mode begins when the SCK active low state coincides with the falling edge of the HOLD# signal. The Hold mode ends when the rising edge of the HOLD# signal coincides with the SCK active low state. If the falling edge of the HOLD# signal does not coincide with the SCK active low state, then the device enters Hold mode when the SCK next reaches the active low state. Similarly, if the rising edge of the HOLD# signal does not coincide with the SCK active low state, then the device exits Hold mode when the SCK next reaches the active low state. See Figure 5 for Hold Condition waveform.

Once the device enters Hold mode, SO will be in high-impedance state while SI and SCK can be V_{IL} or V_{IH} .

If CE# is driven active high during a Hold condition, the device returns to standby mode. The device can then be re-initiated with the command sequences listed in Tables 9 and 10. As long as HOLD# signal is low, the memory remains in the Hold condition. To resume communication with the device, HOLD# must be driven active high, and CE# must be driven active low. See Figure 5 for Hold timing.

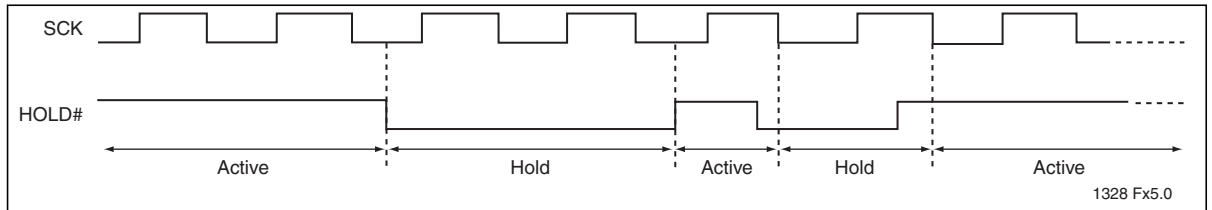

Figure 5: Hold Condition Waveform

Write Protection

SST25WF512/010/020/040 provide software Write protection. The Write Protect pin (WP#) enables or disables the lock-down function of the status register. The Block-Protection bits (BP2, BP1, BP0, and BPL) in the status register provide Write protection to the memory array and the status register. See Table 5 for the Block-Protection description.

Write Protect Pin (WP#)

The Write Protect (WP#) pin enables the lock-down function of the BPL bit (bit 7) in the status register. When WP# is driven low, the execution of the Write-Status-Register (WRSR) instruction is determined by the value of the BPL bit (see Table 3). When WP# is high, the lock-down function of the BPL bit is disabled.

Table 3: Conditions to execute Write-Status-Register (WRSR) Instruction

WP#	BPL	Execute WRSR Instruction
L	1	Not Allowed
L	0	Allowed
H	X	Allowed

T3.0 25016



Status Register

The software status register provides status on whether the flash memory array is available for any Read or Write operation, whether the device is Write enabled, and the state of the Memory Write protection. During an internal Erase or Program operation, the status register may be read only to determine the completion of an operation in progress. Table 4 describes the function of each bit in the software status register.

Table 4: Software Status Register

Bit	Name	Function	Default at Power-up	Read/Write
0	BUSY	1 = Internal Write operation is in progress 0 = No internal Write operation is in progress	0	R
1	WEL	1 = Device is memory Write enabled 0 = Device is not memory Write enabled	0	R
2	BP0	Indicate current level of block write protection (See Tables 5 through 8)	1	R/W
3	BP1	Indicate current level of block write protection (See Tables 5 through 8)	1	R/W
4	BP2	Indicate current level of block write protection (See Tables 5 through 8)	1	R/W
5	RES	Reserved for future use	0	N/A
6	AAI	Auto Address Increment Programming status 1 = AAI programming mode 0 = Byte-Program mode	0	R
7	BPL	1 = BP1 and BP0 are read-only bits 0 = BP1 and BP0 are read/writable	0	R/W

T4.1 25016

Busy

The Busy bit determines whether there is an internal Erase or Program operation in progress. A '1' for the Busy bit indicates the device is busy with an operation in progress. A '0' indicates the device is ready for the next valid operation.

Write Enable Latch (WEL)

The Write-Enable-Latch bit indicates the status of the internal Write-Enable-Latch memory. If the WEL bit is set to '1', it indicates the device is Write enabled. If the bit is set to '0' (reset), it indicates the device is not Write enabled and does not accept any Write (Program/Erase) commands. The Write-Enable-Latch bit is automatically reset under the following conditions:

- Device Reset
- Power-up
- Write-Disable (WRDI) instruction completion
- Byte-Program instruction completion
- Auto Address Increment (AAI) programming is completed or reached its highest unprotected memory address
- Sector-Erase instruction completion
- Block-Erase instruction completion
- Chip-Erase instruction completion
- Write-Status-Register instructions



Auto Address Increment (AAI)

The Auto Address Increment Programming-Status bit provides status on whether the device is in AAI programming mode or Byte-Program mode. The default at power up is Byte-Program mode.

Block-Protection (BP2, BP1, BP0)

The Block-Protection (BP1, BP0) bits define the size of the memory area to be software protected against any memory Write (Program or Erase) operation, see Tables 5-7. The Write-Status-Register (WRSR) instruction is used to program the BP1 and BP0 bits as long as WP# is high or the Block-Protect-Lock (BPL) bit is '0'. Chip-Erase can only be executed if Block-Protection bits are all '0'. After power-up, BP2, BP1, and BP0 are set to defaults. See Table 4 for defaults at power-up.

Block Protection Lock-Down (BPL)

When the WP# pin is driven low (V_{IL}), it enables the Block-Protection-Lock-Down (BPL) bit. When BPL is set to '1', it prevents any further alteration of the BPL, BP1, and BP0 bits. When the WP# pin is driven high (V_{IH}), the BPL bit has no effect and its value is 'Don't Care'. After power-up, the BPL bit is reset to '0'.

Table 5: Software Status Register Block Protection for SST25WF512

Protection Level	Status Register Bit		Protected Memory Address
	BP1 ¹	BP0	512 Kbit
None	0	0	None
1 (Upper Quarter Memory)	0	1	00C000H-00FFFFH
2 (Upper Half Memory)	1	0	008000H-00FFFFH
3 (Full Memory)	1	1	000000H-00FFFFH

T5.1 25016

1. Default at power-up for BP1 and BP0 is '11'.

Table 6: Software Status Register Block Protection for SST25WF010

Protection Level	Status Register Bit		Protected Memory Address
	BP1 ¹	BP0	1 Mbit
None	0	0	None
1 (Upper Quarter Memory)	0	1	018000H-01FFFFH
2 (Upper Half Memory)	1	0	010000H-01FFFFH
3 (Full Memory)	1	1	000000H-01FFFFH

T6.0 25016

1. Default at power-up for BP1 and BP0 is '11'.

Table 7: Software Status Register Block Protection for SST25WF020

Protection Level	Status Register Bit		Protected Memory Address
	BP1 ¹	BP0	2 Mbit
None	0	0	None
1 (Upper Quarter Memory)	0	1	030000H-03FFFFH
2 (Upper Half Memory)	1	0	020000H-03FFFFH
3 (Full Memory)	1	1	000000H-03FFFFH

T7.0 25016

1. Default at power-up for BP1 and BP0 is '11'.



512 Kbit / 1 Mbit / 2 Mbit / 4 Mbit 1.8V SPI Serial Flash

SST25WF512 / SST25WF010 / SST25WF020 / SST25WF040

Table 8: Software Status Register Block Protection for SST25WF040

Protection Level	Protected Blocks	Status Register Bit			Protected Memory Address
		BP2 ¹	BP1	BP0	4 Mbit
None	None	0	0	0	None
1 (Upper Eighth Memory)	Blocks 14 through 15	0	0	1	70000H-7FFFFH
2 (Upper Quarter Memory)	Blocks 12 through 15	0	1	0	60000H-7FFFFH
3 (Upper Half Memory)	Blocks 8 through 15	0	1	1	40000H-7FFFFH
4 (Full Memory)	Blocks 0 through 15	1	0	0	00000H-7FFFFH
5 (Full Memory)	Blocks 0 through 15	1	0	1	00000H-7FFFFH
6 (Full Memory)	Blocks 0 through 15	1	1	0	00000H-7FFFFH
7 (Full Memory)	Blocks 0 through 15	1	1	1	00000H-7FFFFH

T8.0 25016

1. Default at power-up for BP2, BP1, and BP0 is '11'.



512 Kbit / 1 Mbit / 2 Mbit / 4 Mbit 1.8V SPI Serial Flash

SST25WF512 / SST25WF010 / SST25WF020 / SST25WF040

Instructions

Instructions are used to read, write (Erase and Program), and configure the SST25WF512/010/020/040. The instruction bus cycles are 8 bits each for commands (Op Code), data, and addresses. The Write-Enable (WREN) instruction must be executed prior to Byte-Program, Auto Address Increment (AAI) programming, Sector-Erase, Block-Erase, Write-Status-Register, or Chip-Erase instructions. The complete instructions are provided in Tables 9 and 10. All instructions are synchronized off a high-to-low transition of CE#. Inputs will be accepted on the rising edge of SCK starting with the most significant bit. CE# must be driven low before an instruction is entered and must be driven high after the last bit of the instruction has been shifted in (except for Read, Read-ID, and Read-Status-Register instructions). Any low-to-high transition on CE#, before receiving the last bit of an instruction bus cycle, will terminate the instruction in progress and return the device to standby mode. Instruction commands (Op Code), addresses, and data are all input from the most significant bit (MSB) first.

Table 9: Device Operation Instructions for SST25WF512 and SST25WF010

Instruction	Description	Op Code Cycle ¹	Address Cycle(s) ²	Dummy Cycle(s)	Data Cycle(s)	Maximum Frequency
Read	Read Memory	0000 0011b (03H)	3	0	1 to ∞	20 MHz
High-Speed Read	Read Memory at Higher Speed	0000 1011b (0BH)	3	1	1 to ∞	40 MHz
4 KByte Sector-Erase ³	Erase 4 KByte of memory array	0010 0000b (20H)	3	0	0	
32 KByte Block-Erase ⁴	Erase 32 KByte block of memory array	0101 0010b (52H)	3	0	0	
Chip-Erase	Erase Full Memory Array	0110 0000b (60H) or 1100 0111b (C7H)	0	0	0	
Byte-Program	To Program One Data Byte	0000 0010b (02H)	3	0	1	
AAI-Word-Program ⁵	Auto Address Increment Programming	1010 1101b (ADH)	3	0	2 to ∞	
RDSR ⁶	Read-Status-Register	0000 0101b (05H)	0	0	1 to ∞	
EWSR ⁷	Enable-Write-Status-Register	0110 0000b (50H)	0	0	0	
WRSR	Write-Status-Register	0000 0001b (01H)	0	0	1	
WREN ⁷	Write-Enable	0000 0110b (06H)	0	0	0	
WRDI	Write-Disable	0000 0100b (04H)	0	0	0	
RDID ⁸	Read-ID	1001 0000b (90H) or 1010 1011b (ABH)	3	0	1 to ∞	
EBSY	Enable SO to output RY/ BY# status during AAI programming	0111 0000b (70H)	0	0	0	
DBSY	Disable SO to output RY/ BY# status during AAI programming	1000 0000b (80H)	0	0	0	
JEDEC-ID	JEDEC ID read	1001 1111b (9FH)	0	0	3 to ∞	
EHLDD	Enable HOLD# pin func- tionality of the RST#/ HOLD# pin	1010 1010b (AAH)	0	0	0	

T9.0 25016



512 Kbit / 1 Mbit / 2 Mbit / 4 Mbit 1.8V SPI Serial Flash

SST25WF512 / SST25WF010 / SST25WF020 / SST25WF040

1. One bus cycle is eight clock periods.
2. Address bits above the most significant bit of each density can be V_{IL} or V_{IH} .
3. 4 KByte Sector-Erase addresses: use $A_{MS}-A_{12}$, remaining addresses are don't care but must be set either at V_{IL} or V_{IH} .
4. 32 KByte Block-Erase addresses: use $A_{MS}-A_{15}$, remaining addresses are don't care but must be set either at V_{IL} or V_{IH} .
5. To continue programming to the next sequential address location, enter the 8-bit command, ADH, followed by 2 bytes of data to be programmed. Data Byte 0 will be programmed into the initial address $[A_{23}-A_1]$ with $A_0=0$, Data Byte 1 will be programmed into the initial address $[A_{23}-A_1]$ with $A_0 = 1$.
6. The Read-Status-Register is continuous with ongoing clock cycles until terminated by a low to high transition on CE#.
7. Either EWSR or WREN followed by WRSR will write to the Status register. The EWSR-WRSR sequence provides backward compatibility to the SST25VF/LF series. The WREN-WRSR sequence is recommended for new designs.
8. Manufacturer's ID is read with $A_0=0$, and Device ID is read with $A_0=1$. All other address bits are 00H. The Manufacturer's ID and device ID output stream is continuous until terminated by a low-to-high transition on CE#.

Table 10: Device Operation Instructions for SST25WF020 AND SST25WF040

Instruction	Description	Op Code Cycle ¹	Address Cycle(s) ²	Dummy Cycle(s)	Data Cycle(s)	Maximum Frequency
Read	Read Memory	0000 0011b (03H)	3	0	1 to ∞	20 MHz
High-Speed Read	Read Memory at Higher Speed	0000 1011b (0BH)	3	1	1 to ∞	40 MHz
4 KByte Sector-Erase ³	Erase 4 KByte of memory array	0010 0000b (20H)	3	0	0	
32 KByte Block-Erase ⁴	Erase 32 KByte block of memory array	0101 0010b (52H)	3	0	0	
64 KByte Block-Erase ⁵	Erase 64 KByte block of memory array	1101 1000b (D8H)	3	0	0	
Chip-Erase	Erase Full Memory Array	0110 0000b (60H) or 1100 0111b (C7H)	0	0	0	
Byte-Program	To Program One Data Byte	0000 0010b (02H)	3	0	1	
AAI-Word-Program ⁶	Auto Address Increment Programming	1010 1101b (ADH)	3	0	2 to ∞	
RDSR ⁷	Read-Status-Register	0000 0101b (05H)	0	0	1 to ∞	
EWSR ⁸	Enable-Write-Status-Register	0110 0000b (50H)	0	0	0	
WRSR	Write-Status-Register	0000 0001b (01H)	0	0	1	
WREN ⁸	Write-Enable	0000 0110b (06H)	0	0	0	
WRDI	Write-Disable	0000 0100b (04H)	0	0	0	
RDID ⁹	Read-ID	1001 0000b (90H) or 1010 1011b (ABH)	3	0	1 to ∞	
EBSY	Enable SO to output RY/ BY# status during AAI programming	0111 0000b (70H)	0	0	0	
DBSY	Disable SO to output RY/ BY# status during AAI programming	1000 0000b (80H)	0	0	0	
JEDEC-ID	JEDEC ID read	1001 1111b (9FH)	0	0	3 to ∞	
EHLD	Enable HOLD# pin functionality of the RST#/HOLD# pin	1010 1010b (AAH)	0	0	0	

T10.0 25016



1. One bus cycle is eight clock periods.
2. Address bits above the most significant bit of each density can be V_{IL} or V_{IH} .
3. 4 KByte Sector-Erase addresses: use $A_{MS}-A_{12}$, remaining addresses are don't care but must be set either at V_{IL} or V_{IH} .
4. 32 KByte Block-Erase addresses: use $A_{MS}-A_{15}$, remaining addresses are don't care but must be set either at V_{IL} or V_{IH} .
5. 64 KByte Block-Erase addresses: use $A_{MS}-A_{16}$, remaining addresses are don't care but must be set either at V_{IL} or V_{IH} .
6. To continue programming to the next sequential address location, enter the 8-bit command, ADH, followed by 2 bytes of data to be programmed. Data Byte 0 will be programmed into the initial address $[A_{23}-A_1]$ with $A_0=0$, Data Byte 1 will be programmed into the initial address $[A_{23}-A_1]$ with $A_0 = 1$.
7. The Read-Status-Register is continuous with ongoing clock cycles until terminated by a low to high transition on CE#.
8. Either EWSR or WREN followed by WRSR will write to the Status register. The EWSR-WRSR sequence provides backward compatibility to the SST25VF/LF series. The WREN-WRSR sequence is recommended for new designs.
9. Manufacturer's ID is read with $A_0=0$, and Device ID is read with $A_0=1$. All other address bits are 00H. The Manufacturer's ID and device ID output stream is continuous until terminated by a low-to-high transition on CE#.

Read (20 MHz)

The Read instruction, 03H, supports up to 20 MHz Read. The device outputs a data stream starting from the specified address location. The data stream is continuous through all addresses until terminated by a low-to-high transition on CE#. The internal address pointer automatically increments until the highest memory address is reached. Once the highest memory address is reached, the address pointer automatically increments to the beginning (wrap-around) of the address space. For example, for 2 Mbit density, once the data from the address location 3FFFFH is read, the next output is from address location 00000H. The Read instruction is initiated by executing an 8-bit command, 03H, followed by address bits $A_{23}-A_0$. CE# must remain active low for the duration of the Read cycle. See Figure 6 for the Read sequence.

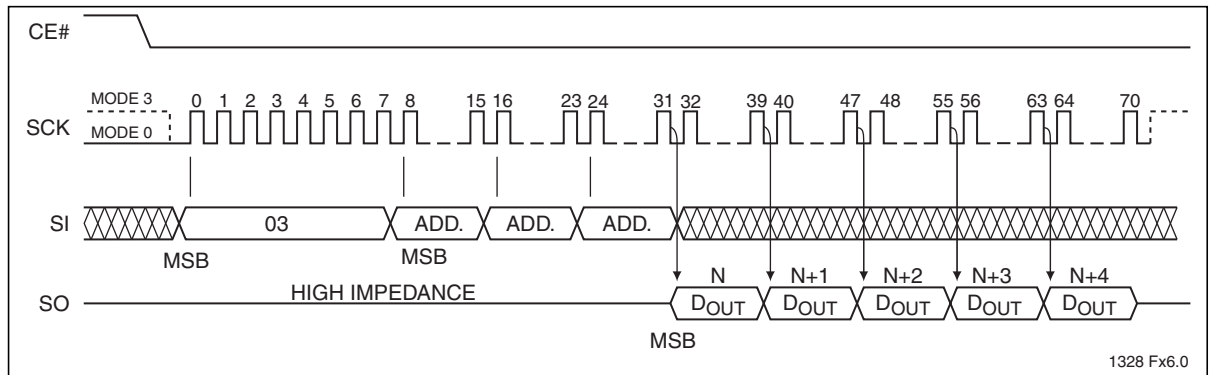

Figure 6: Read Sequence



High-Speed-Read (40 MHz)

The High-Speed-Read instruction supporting up to 40 MHz Read is initiated by executing an 8-bit command, 0BH, followed by address bits [A₂₃-A₀] and a dummy byte. CE# must remain active low for the duration of the High-Speed-Read cycle. See Figure 7 for the High-Speed-Read sequence.

Following a dummy cycle, the High-Speed-Read instruction outputs the data starting from the specified address location. The data output stream is continuous through all addresses until terminated by a low-to-high transition on CE#. The internal address pointer will automatically increment until the highest memory address is reached. Once the highest memory address is reached, the address pointer will automatically increment to the beginning (wrap-around) of the address space. For example, for 2 Mbit density, once the data from address location 3FFFFH is read, the next output will be from address location 000000H.

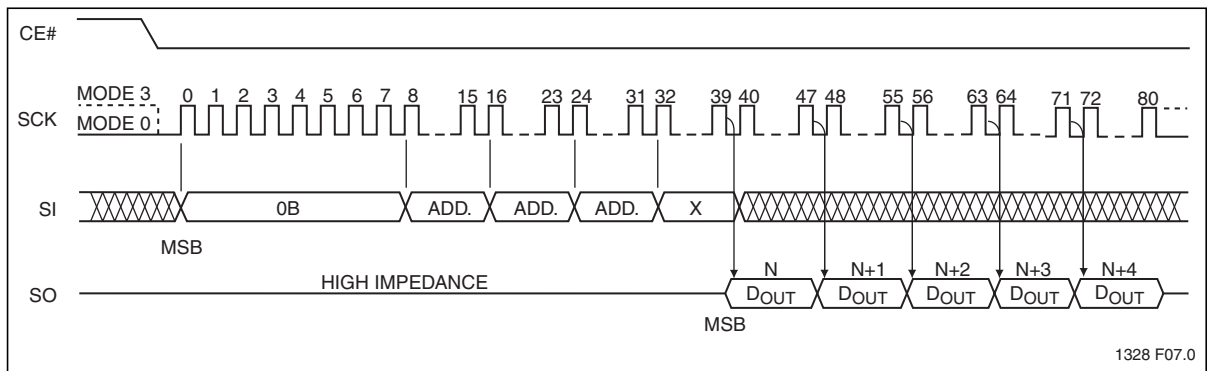

Figure 7: High-Speed-Read Sequence



Byte-Program

The Byte-Program instruction programs the bits in the selected byte to the desired data. The selected byte must be in the erased state (FFH) when initiating a Program operation. A Byte-Program instruction applied to a protected memory area will be ignored.

Prior to any Write operation, the Write-Enable (WREN) instruction must be executed. CE# must remain active low for the duration of the Byte-Program instruction. The Byte-Program instruction is initiated by executing an 8-bit command, 02H, followed by address bits [A₂₃-A₀]. Following the address, the data is input in order from MSB (bit 7) to LSB (bit 0). CE# must be driven high before the instruction is executed. The user may poll the Busy bit in the software status register or wait T_{BP} for the completion of the internal self-timed Byte-Program operation. See Figure 8 for the Byte-Program sequence.

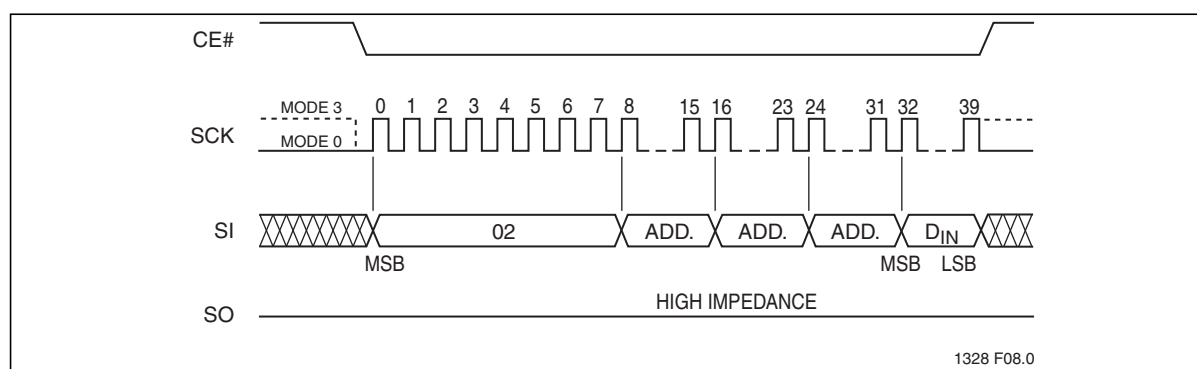

Figure 8: Byte-Program Sequence

Auto Address Increment (AAI) Word-Program

The AAI program instruction allows multiple bytes of data to be programmed without re-issuing the next sequential address location. This feature decreases total programming time when multiple bytes or the entire memory array is to be programmed. An AAI Word program instruction pointing to a protected memory area will be ignored. The selected address range must be in the erased state (FFH) when initiating an AAI Word Program operation. While within AAI Word Programming sequence, the only valid instructions are AAI Word (ADH), RDSR (05H), or WRDI (04H). Users have three options to determine the completion of each AAI Word program cycle: hardware detection by reading the Serial Output, software detection by polling the BUSY bit in the software status register or wait T_{BP}. Refer to End-Of-Write Detection section for details.

Prior to any write operation, the Write-Enable (WREN) instruction must be executed. The AAI Word Program instruction is initiated by executing an 8-bit command, ADH, followed by address bits [A₂₃-A₀]. Following the addresses, two bytes of data are input sequentially, each one from MSB (Bit 7) to LSB (Bit 0). The first byte of data (D0) will be programmed into the initial address [A₂₃-A₁] with A₀ = 0, the second byte of Data (D1) will be programmed into the initial address [A₂₃-A₁] with A₀ = 1. CE# must be driven high before the AAI Word Program instruction is executed. The user must check the BUSY status before entering the next valid command. Once the device indicates it is no longer busy, data for the next two sequential addresses may be programmed and so on. When the last desired byte had been entered, check the busy status using the hardware method or the RDSR instruction and execute the Write-Disable (WRDI) instruction, 04H, to terminate AAI. Check the busy status after WRDI to determine if the device is ready for any command. See Figures 11 and 12 for AAI Word programming sequence.



There is no wrap mode during AAI programming; once the highest unprotected memory address is reached, the device will exit AAI operation and reset the Write-Enable-Latch bit (WEL = 0) and the AAI bit (AAI = 0).

End-of-Write Detection

There are three methods to determine completion of a program cycle during AAI Word programming: hardware detection by reading the Serial Output, software detection by polling the BUSY bit in the Software Status Register or wait T_{BP} .

Hardware End-of-Write Detection

The Hardware End-of-Write detection method eliminates the overhead of polling the Busy bit in the Software Status Register during an AAI Word program operation. The 8-bit command, 70H, configures the Serial Output (SO) pin to indicate Flash Busy status during AAI Word programming, as shown in Figure 9. The 8-bit command, 70H, must be executed prior to executing an AAI Word-Program instruction. Once an internal programming operation begins, asserting CE# will immediately drive the status of the internal flash status on the SO pin. A '0' indicates the device is busy and a '1' indicates the device is ready for the next instruction. De-asserting CE# will return the SO pin to tri-state.

The 8-bit command, 80H, disables the Serial Output (SO) pin to output busy status during AAI-Word-program operation, and re-configures SO as an output pin. In this state, the SO pin will function as a normal Serial Output pin. At this time, the RDSR command can poll the status of the Software Status Register. This is shown in Figure 10.

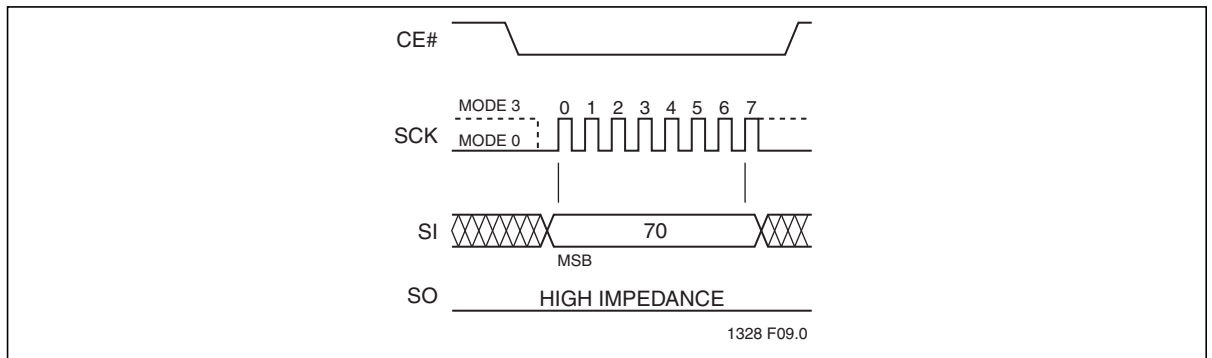

Figure 9: Enable SO as Hardware RY/BY# during AAI Programming

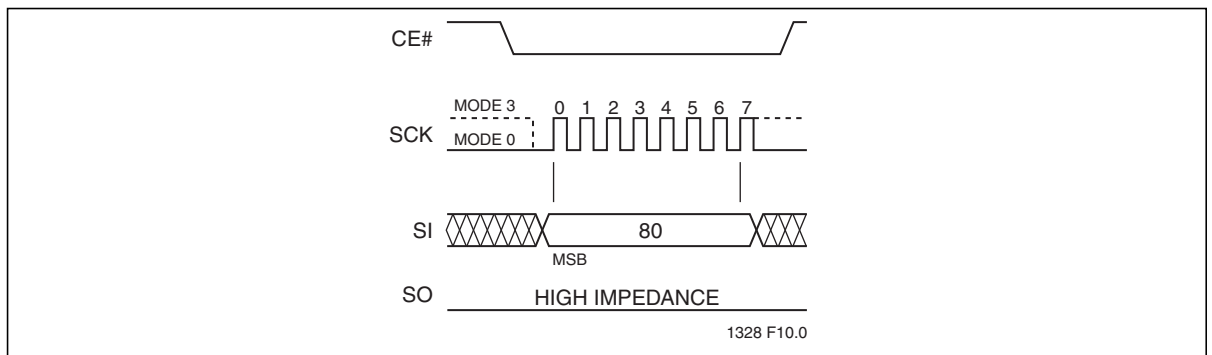

Figure 10: Disable SO as Hardware RY/BY# during AAI Programming

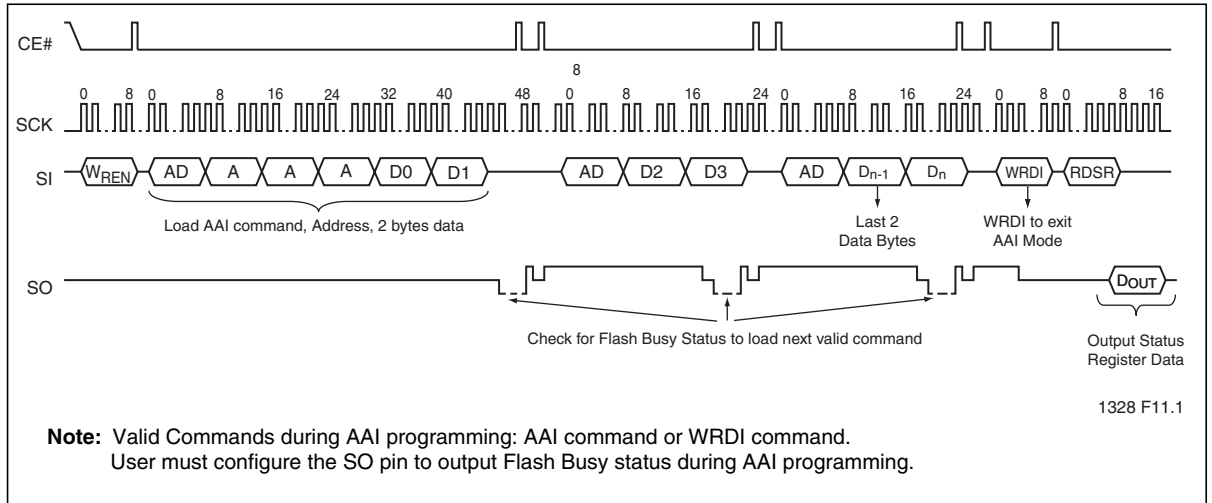

Figure 11:Auto Address Increment (AAI) Word Program Sequence with Hardware End-of-Write Detection

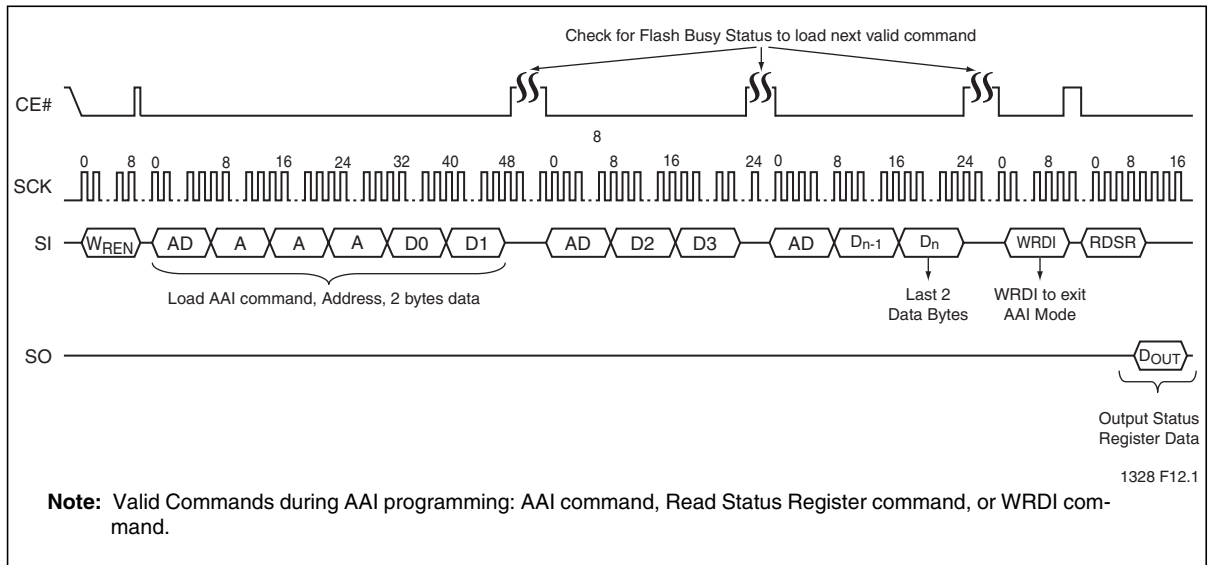

Figure 12:Auto Address Increment (AAI) Word Program Sequence with Software End-of-Write Detection



Sector-Erase

The Sector-Erase instruction clears all bits in the selected 4 KByte sector to FFH. A Sector-Erase instruction applied to a protected memory area will be ignored. Prior to any Write operation, the Write-Enable (WREN) instruction must be executed. CE# must remain active low for the duration of any command sequence. The Sector-Erase instruction is initiated by executing an 8-bit command, 20H, followed by address bits [A₂₃-A₀]. Address bits [A_{MS}-A₁₂] (A_{MS} = Most Significant address) are used to determine the sector address (SA_X), remaining address bits can be V_{IL} or V_{IH}. CE# must be driven high before the instruction is executed. The user may poll the Busy bit in the software status register or wait T_{SE} for the completion of the internal self-timed Sector-Erase cycle. See Figure 13 for the Sector-Erase sequence.

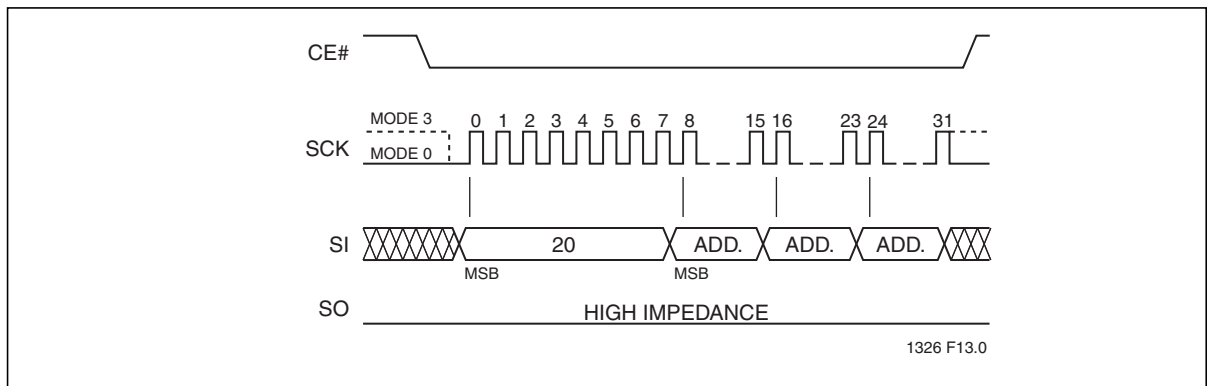

Figure 13: Sector-Erase Sequence

32-KByte Block-Erase

The Block-Erase instruction clears all bits in the selected 32 KByte block to FFH. A Block-Erase instruction applied to a protected memory area is ignored. Prior to any Write operation, the Write-Enable (WREN) instruction must be executed. CE# must remain active low for the duration of any command sequence. The Block-Erase instruction is initiated by executing an 8-bit command, 52H, followed by address bits [A₂₃-A₀]. Address bits [A_{MS}-A₁₅] (A_{MS} = Most Significant Address) are used to determine block address (BA_X), remaining address bits can be V_{IL} or V_{IH}. CE# must be driven high before the instruction is executed. Poll the Busy bit in the software status register or wait T_{BE} for the completion of the internal self-timed Block-Erase. See Figure 14 for the Block-Erase sequences.

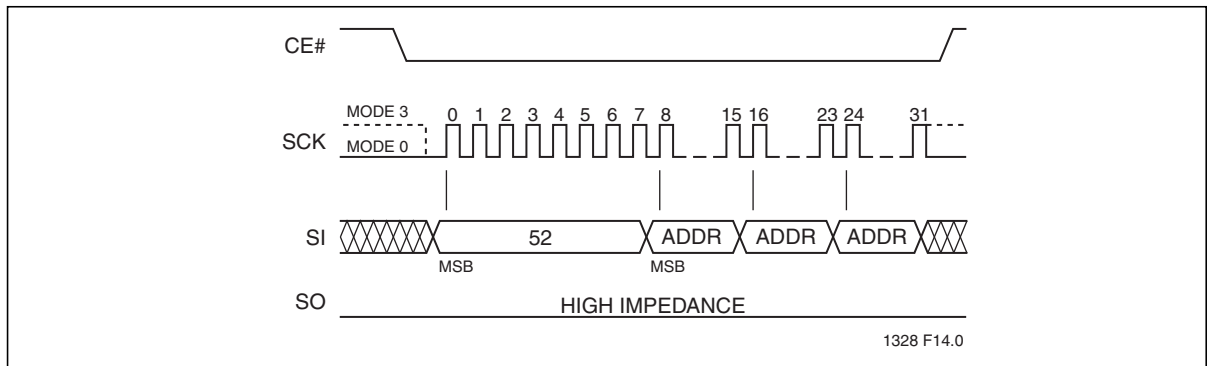

Figure 14: 32-KByte Block-Erase Sequence



64-KByte Block-Erase for SST25WF020 and SST25WF040

The Block-Erase instruction clears all bits in the selected 64 KByte block to FFH. A Block-Erase instruction applied to a protected memory area is ignored. Prior to any Write operation, the Write-Enable (WREN) instruction must be executed. CE# must remain active low for the duration of any command sequence. The Block-Erase instruction is initiated by executing an 8-bit command, D8H, followed by address bits [A₂₃-A₀]. Address bits [A_{MS}-A₁₆] (A_{MS} = Most Significant Address) are used to determine block address (BA_X), remaining address bits can be V_{IL} or V_{IH}. CE# must be driven high before the instruction is executed. Poll the Busy bit in the software status register or wait T_{BE} for the completion of the internal self-timed Block-Erase. See Figure 15 for the Block-Erase sequences.

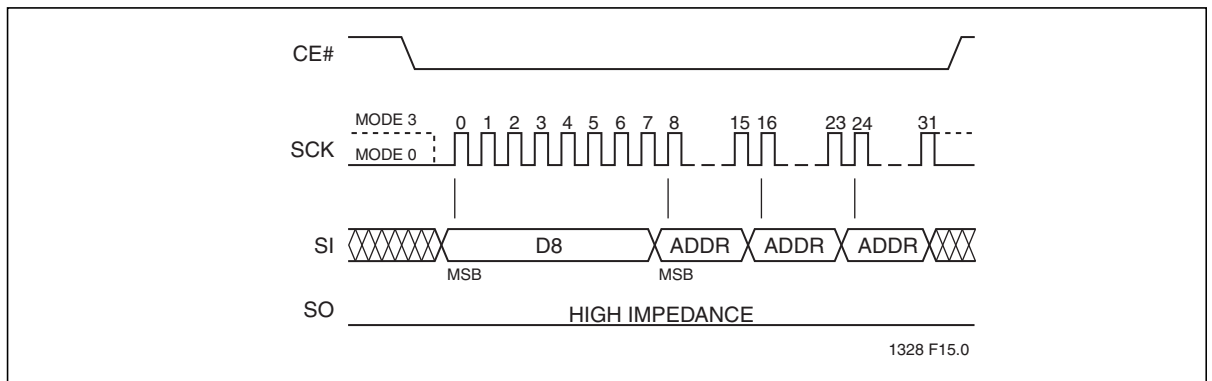

Figure 15:64-KByte Block-Erase Sequence

Chip-Erase

The Chip-Erase instruction clears all bits in the device to FFH. A Chip-Erase instruction is ignored if any of the memory area is protected. Prior to any Write operation, the Write-Enable (WREN) instruction must be executed. CE# must remain active low for the duration of the Chip-Erase instruction sequence. The Chip-Erase instruction is initiated by executing an 8-bit command, 60H or C7H. CE# must be driven high before the instruction is executed. The user may poll the Busy bit in the software status register or wait T_{CE} for the completion of the internal self-timed Chip-Erase cycle. See Figure 16 for the Chip-Erase sequence.

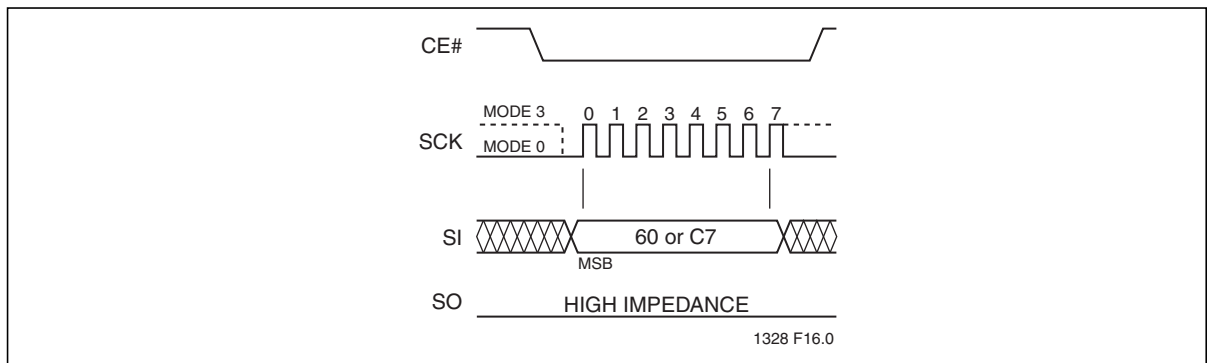

Figure 16:Chip-Erase Sequence



Read-Status-Register (RDSR)

The Read-Status-Register (RDSR) instruction, 05H, allows reading of the status register. The status register may be read at any time even during a Write (Program/Erase) operation. When a Write operation is in progress, the Busy bit may be checked before sending any new commands to assure that the new commands are properly received by the device. CE# must be driven low before the RDSR instruction is entered and remain low until the status data is read. Read-Status-Register is continuous with ongoing clock cycles until it is terminated by a low to high transition of the CE#. See Figure 17 for the RDSR instruction sequence.

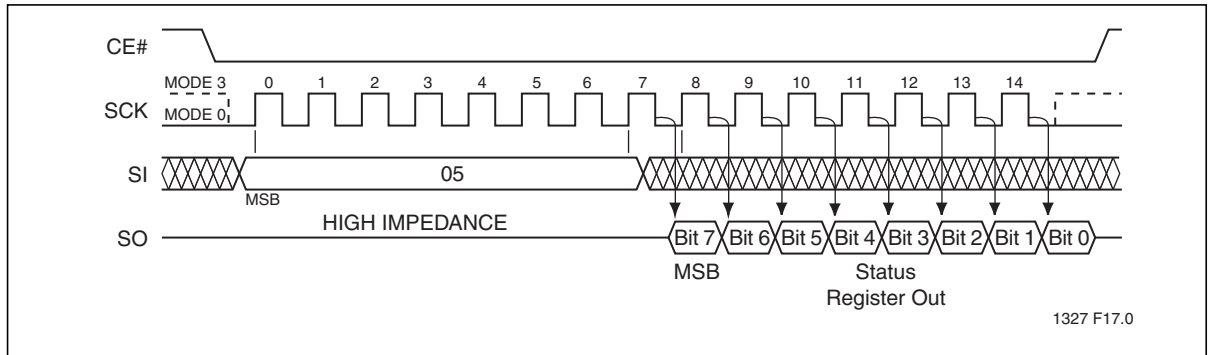

Figure 17: Read-Status-Register (RDSR) Sequence

Write-Enable (WREN)

The Write-Enable (WREN) instruction, 06H, sets the Write-Enable-Latch bit in the Status Register to 1 allowing Write operations to occur. The WREN instruction must be executed prior to any Write (Program/Erase) operation. The WREN instruction may also be used to allow execution of the Write-Status-Register (WRSR) instruction; however, the Write-Enable-Latch bit in the Status Register will be cleared upon the rising edge CE# of the WRSR instruction. CE# must be driven high before the WREN instruction is executed. See Figure 18 for the WREN instruction sequence.

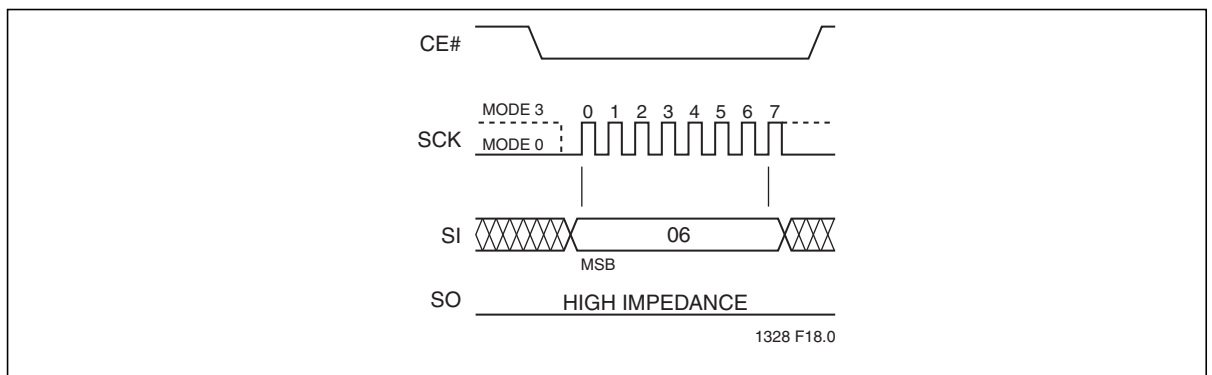

Figure 18: Write Enable (WREN) Sequence



Write-Disable (WRDI)

The Write-Disable (WRDI) instruction, 04H, resets the Write-Enable-Latch bit and AAI to 0 disabling any new Write operations from occurring. The WRDI instruction will not terminate any programming operation in progress. Any program operation in progress may continue up to T_{BP} after executing the WRDI instruction. CE# must be driven high before the WRDI instruction is executed. See Figure 19 for the WRDI instruction sequence.

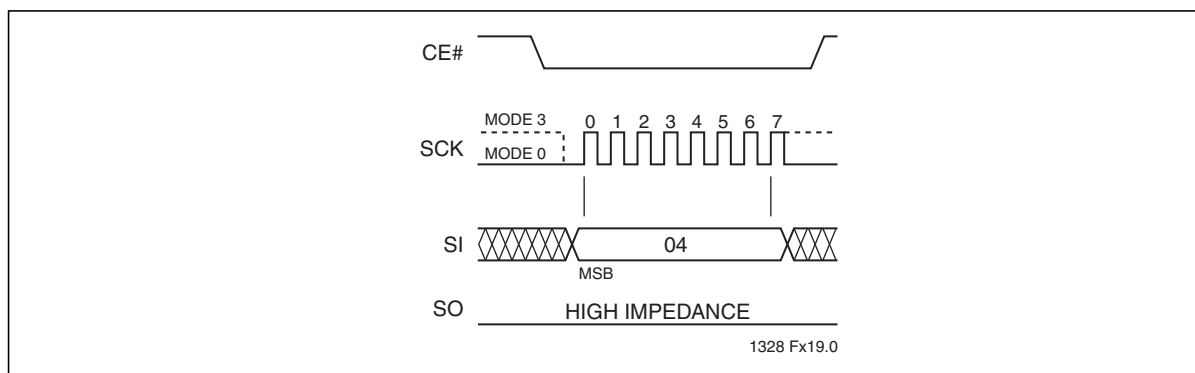

Figure 19: Write Disable (WRDI) Sequence

Enable-Write-Status-Register (EWSR)

The Enable-Write-Status-Register (EWSR) instruction arms the Write-Status-Register (WRSR) instruction and opens the status register for alteration. The Write-Status-Register instruction must be executed immediately after the execution of the Enable-Write-Status-Register instruction. This two-step instruction sequence of the EWSR instruction followed by the WRSR instruction works like SDP (software data protection) command structure which prevents any accidental alteration of the status register values. CE# must be driven low before the EWSR instruction is entered and must be driven high before the EWSR instruction is executed. See Figure 20 for EWSR instruction followed by WRSR instruction.

Write-Status-Register (WRSR)

The Write-Status-Register instruction writes new values to the BP1, BP0, and BPL bits of the status register. CE# must be driven low before the command sequence of the WRSR instruction is entered and driven high before the WRSR instruction is executed. See Figure 20 for EWSR or WREN and WRSR instruction sequences.

Executing the Write-Status-Register instruction will be ignored when WP# is low and BPL bit is set to '1'. When the WP# is low, the BPL bit can only be set from '0' to '1' to lock-down the status register, but cannot be reset from '1' to '0'. When WP# is high, the lock-down function of the BPL bit is disabled and the BPL, BP0, and BP1 bits in the status register can all be changed. As long as BPL bit is set to '0' or WP# pin is driven high (V_{IH}) prior to the low-to-high transition of the CE# pin at the end of the WRSR instruction, the bits in the status register can all be altered by the WRSR instruction. In this case, a sin-



gle WRSR instruction can set the BPL bit to '1' to lock down the status register as well as altering the BP0, and BP1 bits at the same time. See Table 3 for a summary description of WP# and BPL functions.

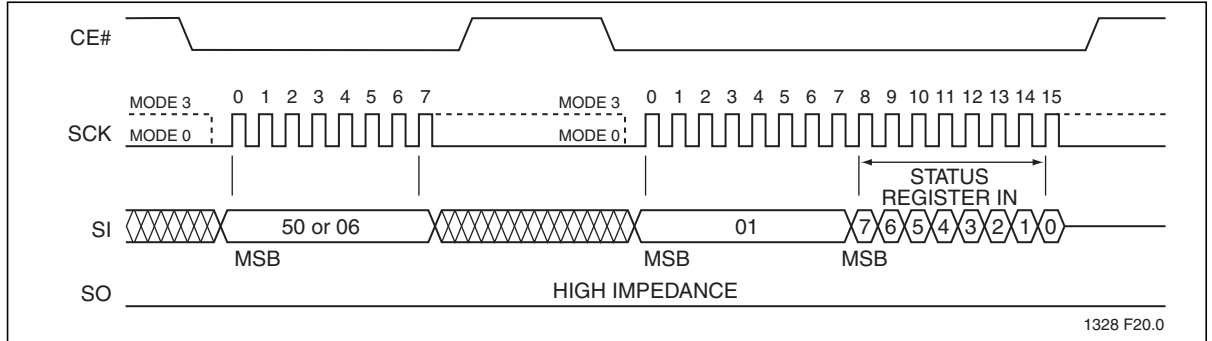

Figure 20: Enable-Write-Status-Register (EWSR) or Write-Enable (WREN) and Write-Status-Register (WRSR) Sequence

Enable-Hold (EHLD)

The 8-bit command, AAH, Enable-Hold instruction enables the HOLD functionality of the RST#/HOLD# pin. CE# must remain active low for the duration of the Enable-Hold instruction sequence. CE# must be driven high before the instruction is executed. See Figure 21 for the Enable-Hold instruction sequence.

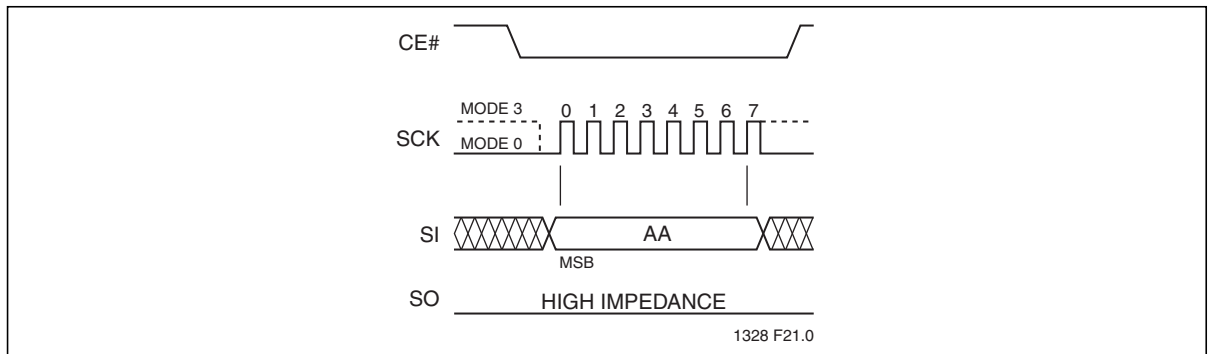

Figure 21: Enable-Hold Sequence



Read-ID

The Read-ID instruction identifies the manufacturer as SST and the device as SST25WF512/010/020/040. Use the Read-ID instruction to identify SST device when using multiple manufacturers in the same socket. See Table 11.

The device information is read by executing an 8-bit command, 90H or ABH, followed by address bits [A₂₃-A₀]. Following the Read-ID instruction, the manufacturer's ID is located in address 000000H and the device ID is located in address 000001H. Once the device is in Read-ID mode, the manufacturer's and device ID output data toggles between address 000000H and 000001H until terminated by a low to high transition on CE#.

Table 11:Product Identification

	Address	Data
Manufacturer's ID	000000H	BFH
Device ID		
SST25WF512	000001H	01H
SST25WF010	000001H	02H
SST25WF020	000001H	03H
SST25WF040	000001H	04H

T11.25016

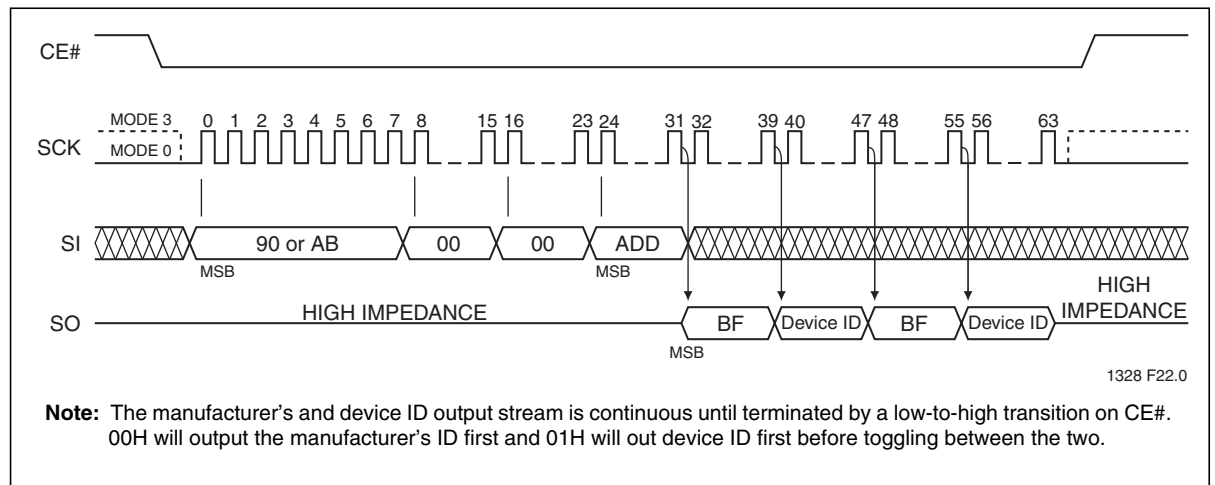

Figure 22:Read-ID Sequence



JEDEC Read-ID

The JEDEC Read-ID instruction identifies the device as SST25WF512/010/020/040 and the manufacturer as SST. The device information can be read from executing the 8-bit command, 9FH. Following the JEDEC Read-ID instruction, the 8-bit manufacturer's ID, BFH, is output from the device. After that, a 16-bit device ID is shifted out on the SO pin. The Device ID is assigned by the manufacturer and contains the type of memory in the first byte and the memory capacity of the device in the second byte. See Figure 23 for the instruction sequence. The JEDEC Read ID instruction is terminated by a low to high transition on CE# at any time during data output.

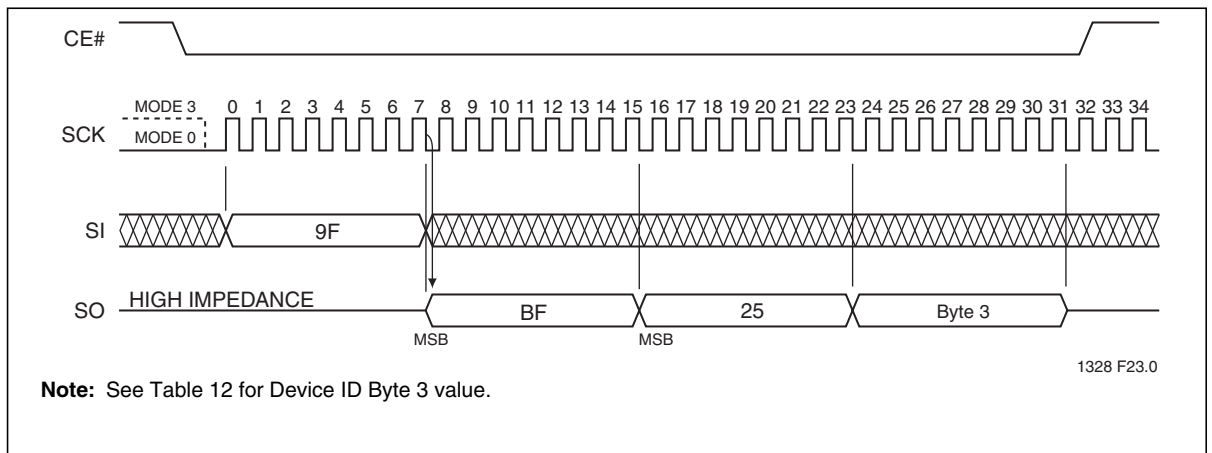

Figure 23: JEDEC Read-ID Sequence

Table 12: JEDEC Read-ID Data-Out for SST25WF512

Product	Manufacturer's ID (Byte 1)	Device ID	
		Memory Type (Byte 2)	Memory Capacity (Byte 3)
SST25WF512	BFH	25H	01H
SST25WF010	BFH	25H	02H
SST25WF020	BFH	25H	03H
SST25WF040	BFH	25H	04H

T12.0 25016



Electrical Specifications

Absolute Maximum Stress Ratings (Applied conditions greater than those listed under “Absolute Maximum Stress Ratings” may cause permanent damage to the device. This is a stress rating only and functional operation of the device at these conditions or conditions greater than those defined in the operational sections of this data sheet is not implied. Exposure to absolute maximum stress rating conditions may affect device reliability.)

Temperature Under Bias	-55°C to +125°C
Storage Temperature.	-65°C to +150°C
D. C. Voltage on Any Pin to Ground Potential.	-0.5V to $V_{DD}+0.5V$
Transient Voltage (<20 ns) on Any Pin to Ground Potential	-2.0V to $V_{DD}+2.0V$
Package Power Dissipation Capability ($T_A = 25^\circ C$).	1.0W
Surface Mount Solder Reflow Temperature	260°C for 10 seconds
Output Short Circuit Current ¹	50 mA

1. Output shorted for no more than one second. No more than one output shorted at a time.

Table 13: Operating Range

Range	Ambient Temp	V_{DD}
Industrial	-40°C to +85°C	1.65-1.95V
Industrial (extended) ¹	-40°C to +105°C	1.70-1.90V

T13.1 25016

1. Contact SST Sales for available extended industrial temperature devices.

Table 14: AC Conditions of Test

Input Rise/Fall Time	Output Load
5ns	$C_L = 30\text{ pF}$

T14.1 25016



Power-Up Specifications

All functionalities and DC specifications are specified for a V_{DD} ramp rate of greater than 1V per 100 ms (0V to 1.8V in less than 180 ms). If the V_{DD} ramp rate is slower than 1V/100 μ s, a hardware reset is required. The recommended V_{DD} power-up to RESET# high time should be greater than 100 μ s to ensure a proper reset. See Table 15 and Figures 24 and 25 for more information.

Table 15: Recommended System Power-up Timings

Symbol	Parameter	Minimum	Units
$T_{PU-READ}^1$	V_{DD} Min to Read Operation	100	μ s
$T_{PU-WRITE}^1$	V_{DD} Min to Write Operation	100	μ s

T15.0 25016

1. This parameter is measured only for initial qualification and after a design or process change that could affect this parameter.

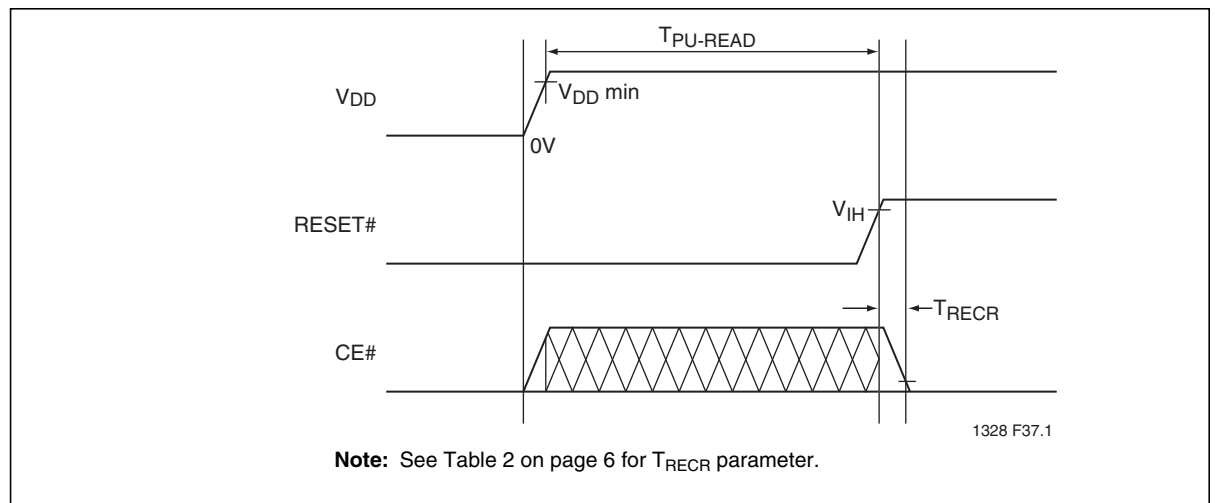

Figure 24: Power-Up Reset Diagram



512 Kbit / 1 Mbit / 2 Mbit / 4 Mbit 1.8V SPI Serial Flash

SST25WF512 / SST25WF010 / SST25WF020 / SST25WF040

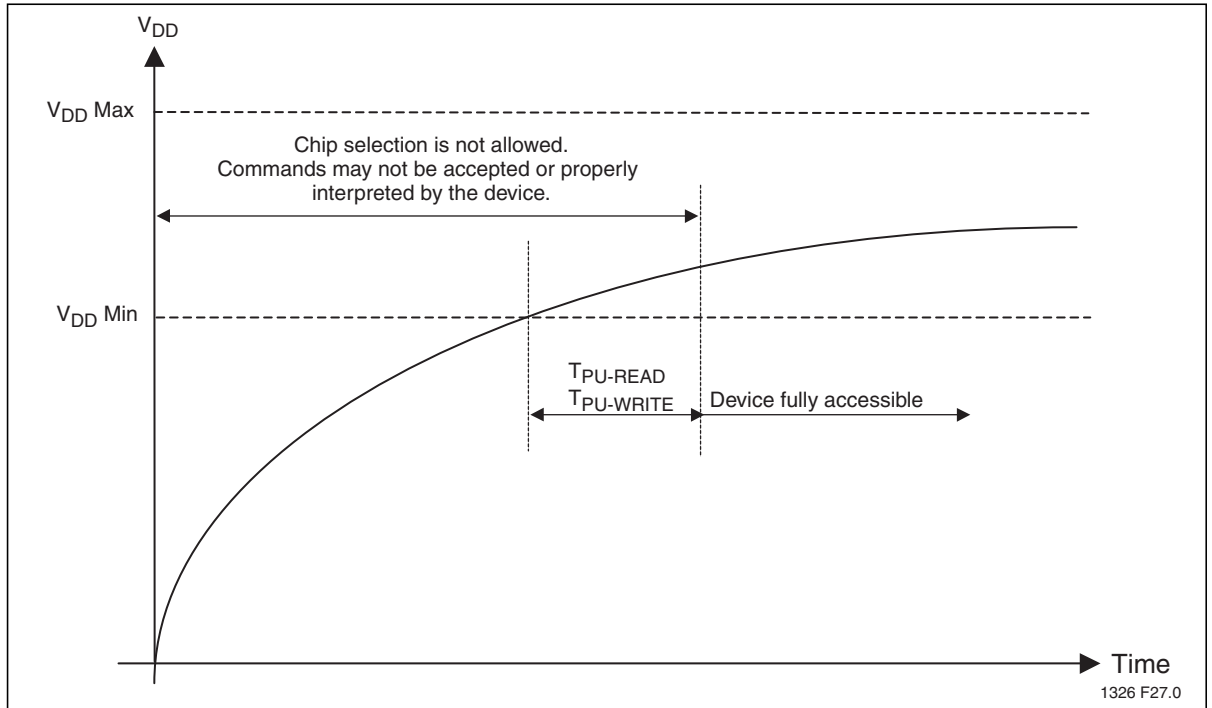

Figure 25: Power-up Timing Diagram



DC Characteristics

Table 16:DC Operating Characteristics

Symbol	Parameter	Limits				Test Conditions
		Min	Typ ¹	Max	Units	
I _{DDR}	Read Current		2	5	mA	CE#=0.1 V _{DD} /0.9 V _{DD} @20 MHz, SO=open
I _{DDR2}	Read Current		4	10	mA	CE#=0.1 V _{DD} /0.9V _{DD} @40 MHz, SO=open
I _{DDW}	Program and Erase Current		6	10	mA	CE#=V _{DD}
I _{SB}	Standby Current		2	8	μA	CE#=V _{DD} , V _{IN} =V _{DD} or V _{SS}
I _{LI}	Input Leakage Current			1	μA	V _{IN} =GND to V _{DD} , V _{DD} =V _{DD} Max
I _{LO}	Output Leakage Current			1	μA	V _{OUT} =GND to V _{DD} , V _{DD} =V _{DD} Max
V _{IL}	Input Low Voltage			0.3	V	V _{DD} =V _{DD} Min
V _{IH}	Input High Voltage	0.7 V _{DD}			V	V _{DD} =V _{DD} Max
V _{OL}	Output Low Voltage			0.2	V	I _{OL} =100 μA, V _{DD} =V _{DD} Min
V _{OH}	Output High Voltage	V _{DD} -0.2			V	I _{OH} =-100 μA, V _{DD} =V _{DD} Min

T16.0 25016

1. Value characterized, not fully tested in production.

Table 17:Capacitance (T_A = 25°C, f=1 Mhz, other pins open)

Parameter	Description	Test Condition	Maximum
C _{OUT} ¹	Output Pin Capacitance	V _{OUT} = 0V	12 pF
C _{IN} ¹	Input Capacitance	V _{IN} = 0V	6 pF

T17.0 25016

1. This parameter is measured only for initial qualification and after a design or process change that could affect this parameter.

Table 18:Reliability Characteristics

Symbol	Parameter	Minimum Specification	Units	Test Method
N _{END} ¹	Endurance	100,000	Cycles	JEDEC Standard A117
T _{DR} ¹	Data Retention	100	Years	JEDEC Standard A103
I _{LTH} ¹	Latch Up	100 + I _{DD}	mA	JEDEC Standard 78

T18.0 25016

1. This parameter is measured only for initial qualification and after a design or process change that could affect this parameter.



AC Characteristics

Table 19: AC Operating Characteristics

Symbol	Parameter	Limits - 20 MHz		Limits - 40 MHz		Units
		Min	Max	Min	Max	
F _{CLK} ¹	Serial Clock Frequency		20		40	MHz
T _{SCKH}	Serial Clock High Time	20		11		ns
T _{SCKL}	Serial Clock Low Time	20		11		ns
T _{SCKR}	Serial Clock Rise Time		5		5	ns
T _{SCKF}	Serial Clock Fall Time		5		5	ns
T _{CES} ²	CE# Active Setup Time	20		8		ns
T _{CEH} ²	CE# Active Hold Time	20		8		ns
T _{CHS} ²	CE# Not Active Setup Time	10		10		ns
T _{CHH} ²	CE# Not Active Hold Time	10		10		ns
T _{CPH}	CE# High Time	50		25		ns
T _{CHZ}	CE# High to High-Z Output		20		19	ns
T _{CLZ}	SCK Low to Low-Z Output	0		0		ns
T _{DS}	Data In Setup Time	5		2		ns
T _{DH}	Data In Hold Time	5		5		ns
T _{HLS}	HOLD# Low Setup Time	10		8		ns
T _{HHS}	HOLD# High Setup Time	10		8		ns
T _{HLH}	HOLD# Low Hold Time	15		12		ns
T _{HHH}	HOLD# High Hold Time	10		10		ns
T _{HZ}	HOLD# Low to High-Z Output		20		20	ns
T _{LZ}	HOLD# High to Low-Z Output		20		20	ns
T _{OH}	Output Hold from SCK Change	0		0		ns
T _V	Output Valid from SCK		20		9	ns
T _{SE}	Sector-Erase		75		75	ms
T _{BE}	Block-Erase		75		75	ms
T _{SCE}	Chip-Erase		150		150	ms
T _{BP} ³	Byte-Program		60		60	μs

T19.1 25016

1. Maximum clock frequency for Read instruction, 03H, is 20 MHz
2. Relative to SCK
3. AAI-Word Program T_{BP} maximum specification is also at 60 μs maximum time



512 Kbit / 1 Mbit / 2 Mbit / 4 Mbit 1.8V SPI Serial Flash

SST25WF512 / SST25WF010 / SST25WF020 / SST25WF040

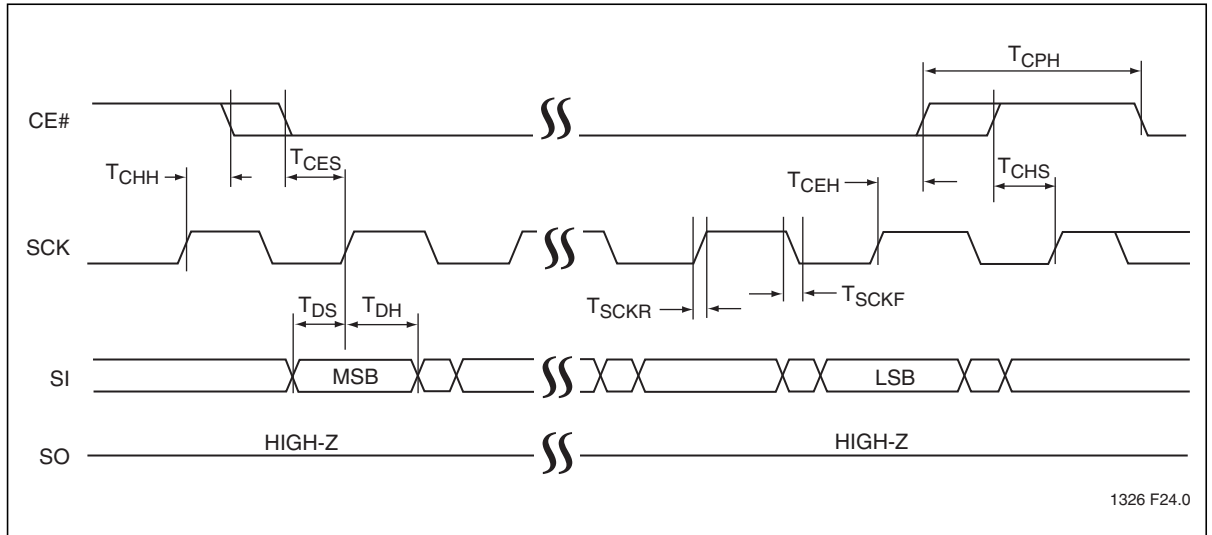

1326 F24.0

Figure 26: Serial Input Timing Diagram

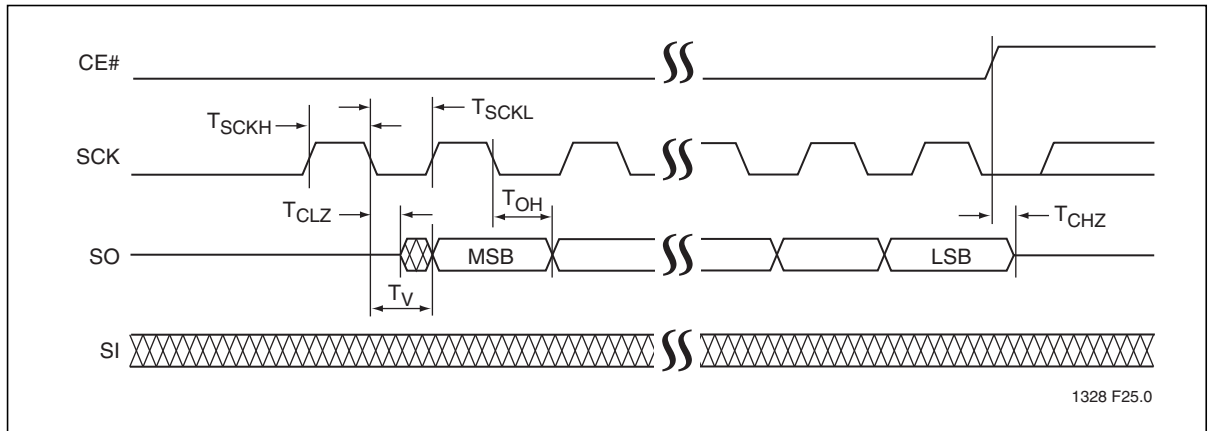

1328 F25.0

Figure 27: Serial Output Timing Diagram

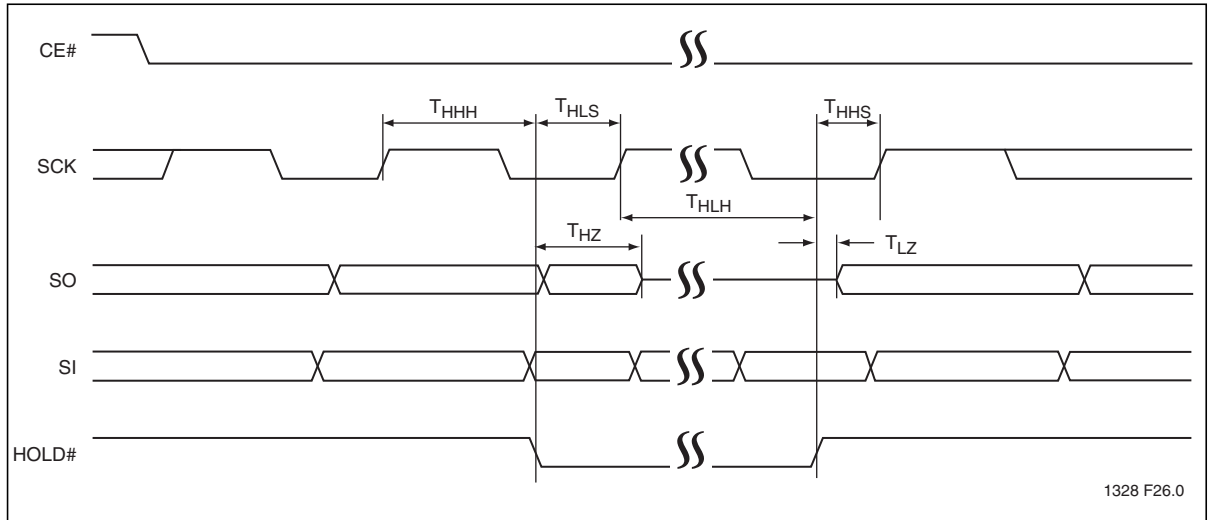

Figure 28: Hold Timing Diagram

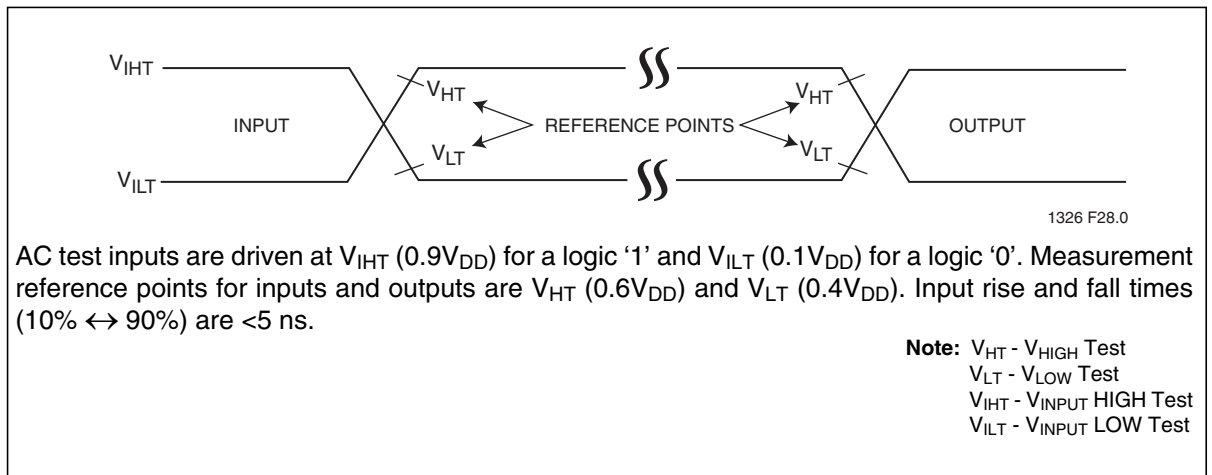
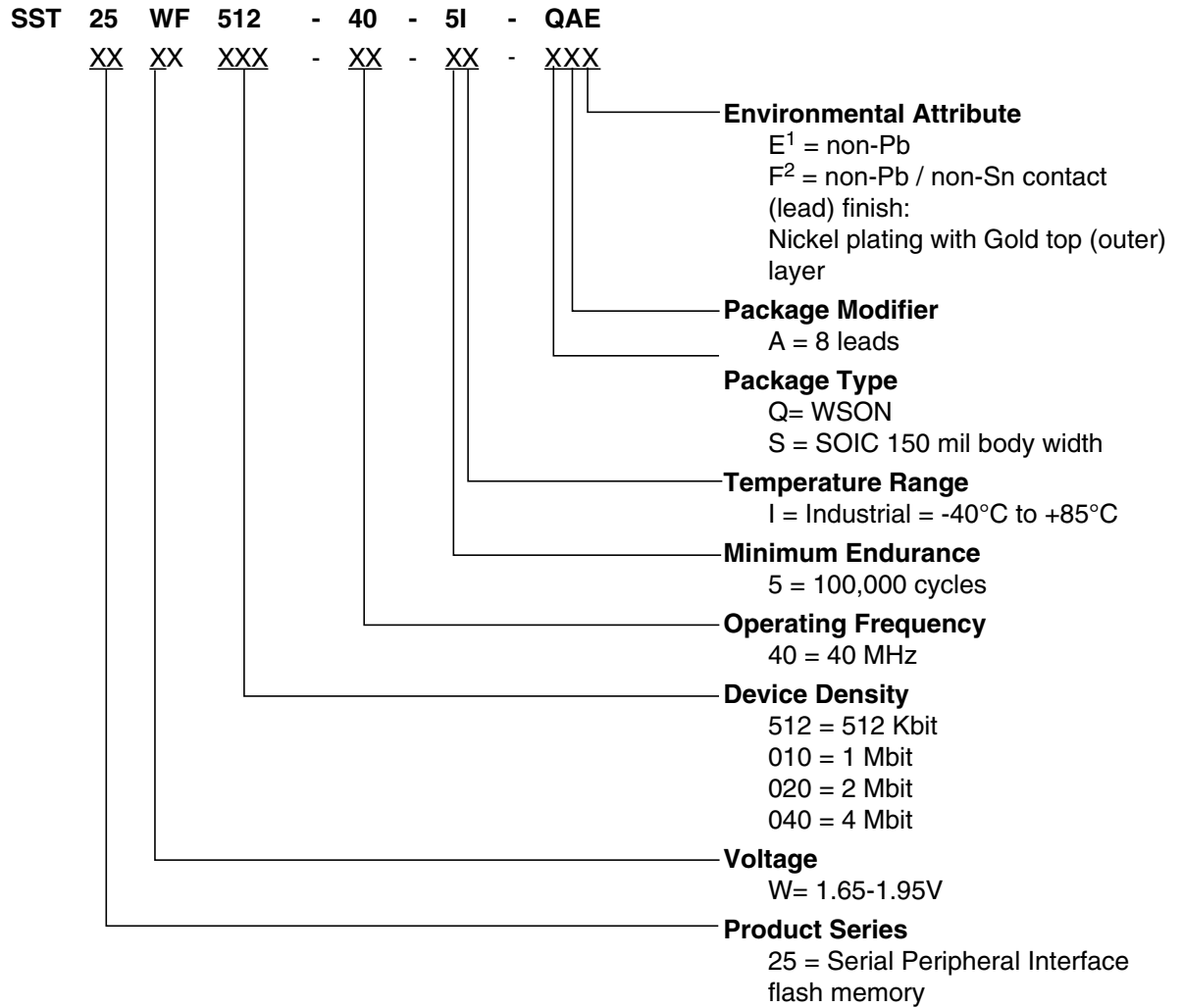

Figure 29: AC Input/Output Reference Waveforms



512 Kbit / 1 Mbit / 2 Mbit / 4 Mbit 1.8V SPI Serial Flash SST25WF512 / SST25WF010 / SST25WF020 / SST25WF040

Product Ordering Information



1. Environmental suffix "E" denotes non-Pb solder. SST non-Pb solder devices are "RoHS Compliant".
2. Environmental suffix "F" denotes non-Pb/non-SN solder. SST non-Pb/non-Sn solder devices are "RoHS Compliant".



A Microchip Technology Company

512 Kbit / 1 Mbit / 2 Mbit / 4 Mbit 1.8V SPI Serial Flash

SST25WF512 / SST25WF010 / SST25WF020 / SST25WF040

Data Sheet

Valid Combinations for SST25WF512

SST25WF512-40-5I-SAF

Valid Combinations for SST25WF010

SST25WF010-40-5I-SAF

Valid Combinations for SST25WF020

SST25WF020-40-5I-SAF SST25WF020-40-5I-QAE

Valid Combinations for SST25WF040

SST25WF040-40-5I-SAF SST25WF040-40-5I-QAE

Note: Valid combinations are those products in mass production or will be in mass production. Consult your SST sales representative to confirm availability of valid combinations and to determine availability of new combinations.



Packaging Diagrams

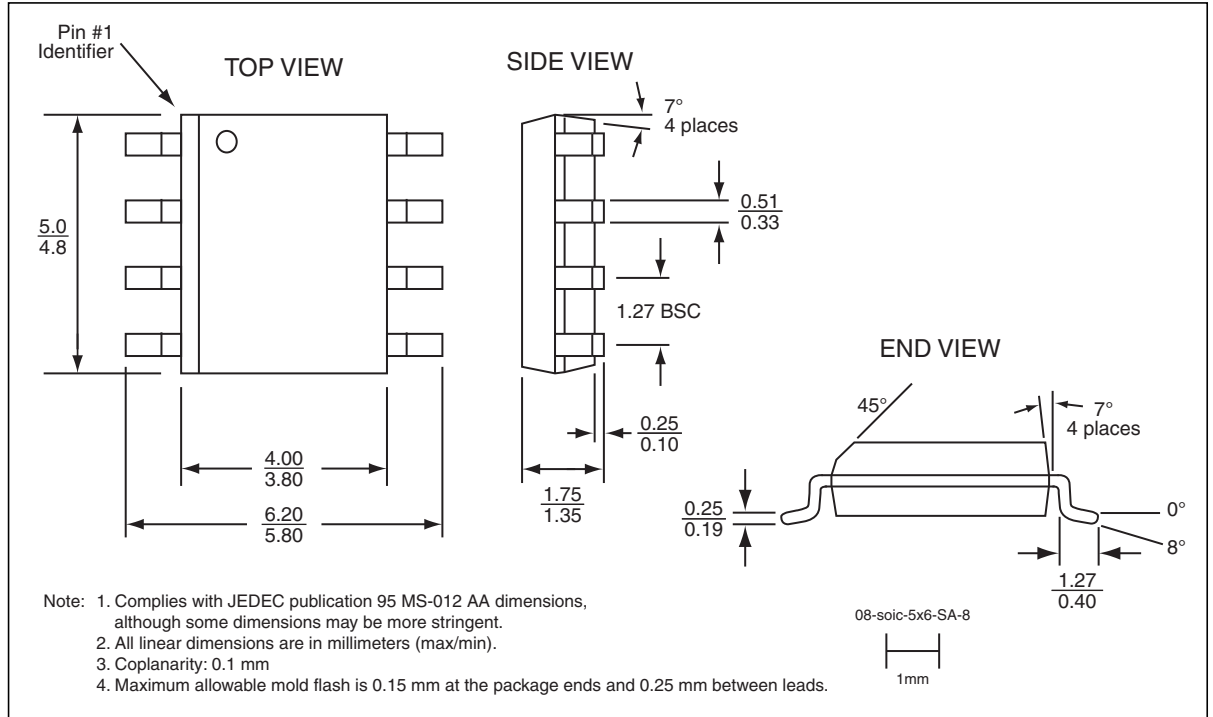

Figure 30: 8-Lead Small Outline Integrated Circuit (SOIC)
SST Package Code: SA



512 Kbit / 1 Mbit / 2 Mbit / 4 Mbit 1.8V SPI Serial Flash

SST25WF512 / SST25WF010 / SST25WF020 / SST25WF040

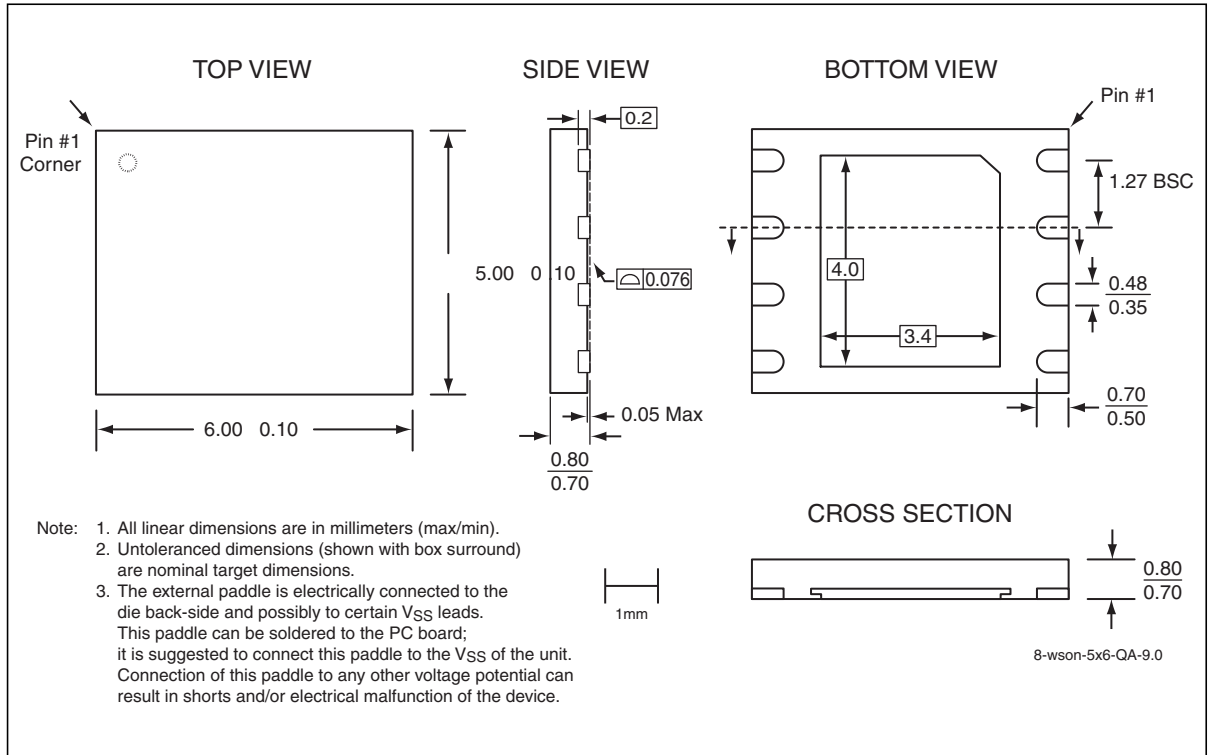

Figure 31: 8-Contact Very-very-thin Small Outline No-lead (WSON)
SST Package Code: QA

Table 20: Revision History

Number	Description	Date
00	Initial release of data sheet	Nov 2006
01	<ul style="list-style-type: none"> Removed "Commercial" Temperature Range Added references to Tables 6 and 7 in "Block-Protection (BP2, BP1, BP0)" on page 9 Modified EWSR and WREN footnote information and updated EBSY Op Code Cycle in Tables 9 and 10 Re-phrased first paragraph in "Instructions" on page 11 Updated "Byte-Program" on page 15 Clarified SO pin statement in second paragraph of "Hardware End-of-Write Detection" on page 16 Added Industrial (extended) values to Operating Range in "Electrical Specifications" on page 25 Added "Power-Up Specifications" on page 26 Added typical values to Table 16 on page 28 Added contact-lead composition, updated minimum endurance from 10,000 to 100,000 cycles, and changed product valid combinations in "Product Ordering Information" on page 32 	Feb 2007

**Table 20:** Revision History (Continued)

Number	Description	Date
02	<ul style="list-style-type: none"> Added SST25WF040 product to this data sheet Changed 01/02/03 in Figure 21 to Byte 3 and revised note. Updated I_{LO} and I_{LI} values in Table 16 Updated T_{CPH} values in Table 19 	Aug 2007
03	<ul style="list-style-type: none"> Corrected heading typo throughout Modified Table 8 on page 10 	Oct 2007
04	<ul style="list-style-type: none"> Updated Power Consumption Specs in Features on page 1 and in Table 16 on page 25 Changed Standby Current to 2 μA in Features Edited Table 16, "DC Operating Characteristics," on page 28 I_{DDR2} Typ 4 mA and I_{SB} Typ/Max 2/8 μA 	May 2008
05	<ul style="list-style-type: none"> Changed document status from Preliminary Specification to Data sheet 	Aug 2008
06	<ul style="list-style-type: none"> Added information for QAE package. 	Aug 2009
07	<ul style="list-style-type: none"> Revised footnote for Table 13, "Operating Range," on page 25 	Sep 2009
08	<ul style="list-style-type: none"> Added valid combination SST25WF040-40-5I-QAE 	Nov 2009
A	<ul style="list-style-type: none"> Applied new document format Released document under letter revision system Updated spec S71328 to DS25016 	Jun 2011

ISBN:978-1-61341-244-2

© 2011 Silicon Storage Technology, Inc—a Microchip Technology Company. All rights reserved.

SST, Silicon Storage Technology, the SST logo, SuperFlash, MTP, and FlashFlex are registered trademarks of Silicon Storage Technology, Inc. MPF, SQI, Serial Quad I/O, and Z-Scale are trademarks of Silicon Storage Technology, Inc. All other trademarks and registered trademarks mentioned herein are the property of their respective owners.

Specifications are subject to change without notice. Refer to www.microchip.com for the most recent documentation. For the most current package drawings, please see the Packaging Specification located at <http://www.microchip.com/packaging>.

Memory sizes denote raw storage capacity; actual usable capacity may be less.

SST makes no warranty for the use of its products other than those expressly contained in the Standard Terms and Conditions of Sale.

For sales office(s) location and information, please see www.microchip.com.

Silicon Storage Technology, Inc.
A Microchip Technology Company
www.microchip.com



Компания «ЭлектроПласт» предлагает заключение долгосрочных отношений при поставках импортных электронных компонентов на взаимовыгодных условиях!

Наши преимущества:

- Оперативные поставки широкого спектра электронных компонентов отечественного и импортного производства напрямую от производителей и с крупнейших мировых складов;
- Поставка более 17-ти миллионов наименований электронных компонентов;
- Поставка сложных, дефицитных, либо снятых с производства позиций;
- Оперативные сроки поставки под заказ (от 5 рабочих дней);
- Экспресс доставка в любую точку России;
- Техническая поддержка проекта, помощь в подборе аналогов, поставка прототипов;
- Система менеджмента качества сертифицирована по Международному стандарту ISO 9001;
- Лицензия ФСБ на осуществление работ с использованием сведений, составляющих государственную тайну;
- Поставка специализированных компонентов (Xilinx, Altera, Analog Devices, Intersil, Interpoint, Microsemi, Aeroflex, Peregrine, Syfer, Eurofarad, Texas Instrument, Miteq, Cobham, E2V, MA-COM, Hittite, Mini-Circuits, General Dynamics и др.);

Помимо этого, одним из направлений компании «ЭлектроПласт» является направление «Источники питания». Мы предлагаем Вам помощь Конструкторского отдела:

- Подбор оптимального решения, техническое обоснование при выборе компонента;
- Подбор аналогов;
- Консультации по применению компонента;
- Поставка образцов и прототипов;
- Техническая поддержка проекта;
- Защита от снятия компонента с производства.



Как с нами связаться

Телефон: 8 (812) 309 58 32 (многоканальный)

Факс: 8 (812) 320-02-42

Электронная почта: org@eplast1.ru

Адрес: 198099, г. Санкт-Петербург, ул. Калинина, дом 2, корпус 4, литера А.