

NOTE



All numerical values are in metric units [with U.S. customary units in brackets]. Dimensions are in millimeters [and inches]. Unless otherwise specified, dimensions have a tolerance of ± 0.13 [± 0.005] and angles have a tolerance of $\pm 2^\circ$. Figures and illustrations are for identification only and are not drawn to scale.

1. INTRODUCTION

This specification covers the requirements for application of AUGAT HOLTITE Sockets. These manually applied or reel-mounted machine applied solderless spring sockets are designed to be contained within the barrel of a plated-through hole. The design allows the socket and plated-through hole to form a zero-profile component socket which provides an interconnect for a broad range of electronic parts and components. The sockets are available in a variety of different series and sizes based on printed circuit (pc) board hole diameter. They are also available normally on mylar strips which can be reeled on custom socket patterns for ease of application.

When corresponding with TE Connectivity (TE) Personnel, use the terminology provided in this specification to facilitate your inquiries for information. Basic terms and features of this product are provided in Figure 1.

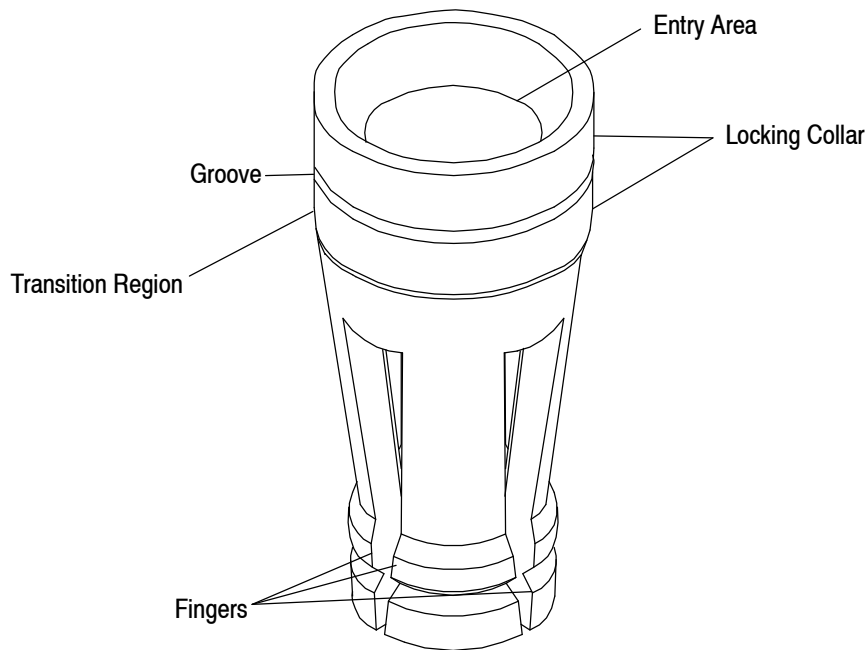

Figure 1

2. REFERENCE MATERIAL

2.1. Revision Summary

- Updated document to corporate requirements
- New logo

2.2. Customer Assistance

Reference Part Number 6-1437514-7 and Product Code E354 are representative numbers of AUGAT HOLTITE Sockets. Use of these numbers will identify the product line and expedite your inquiries through a service network established to help you obtain product and tooling information. Such information can be obtained through a local TE Representative or, after purchase, by calling the Tooling Assistance Center or Product Information number at the bottom of this page.

2.3. Drawings

Customer Drawings for specific products are available from the service network. The information contained in Customer Drawings takes priority if there is a conflict with this specification or with any other technical documentation supplied by TE.

2.4. Specifications

Product specification 108-1979 provides product performance requirements and test information.

2.5. Instructional Material

The following list includes available instruction sheets (408-series) that provide assembly procedures for operation, maintenance and repair of tooling; and customer manuals (409-series) that provide setup, operation, and maintenance of machines.

<u>Document Number</u>	<u>Document Title</u>
408-3295	Preparing Reel of Contacts for Application Tooling
408-6732	Pneumatic Auto-Cycle Unit 91112-3
408-6923	Manual Arbor Frame Assembly 58024-1
408-7777	Manual Arbor Frame Assembly 91085-2
408-9816	Handling of Reeled Products
409-5626	SM-3 Machine No. 814700-[]

3. REQUIREMENTS

3.1. Storage

A. Ultraviolet Light

Prolonged exposure to ultraviolet light may deteriorate the chemical composition used in the socket.

B. Shelf Life

The sockets should remain in the shipping containers until ready for use to prevent deformation to the sockets. The sockets should be used on a first in, first out basis to avoid storage contamination that could adversely affect signal transmissions.

C. Chemical Exposure

Do not store sockets near any chemicals listed below, as stress corrosion cracking in the sockets may occur.

Alkalies	Ammonia	Citrates	Phosphates	Citrates	Sulfur Compounds
Amines	Carbonates	Nitrites	Sulfur	Nitrites	Tartrates

3.2. Material

All sockets are made of beryllium-copper with gold, tin/lead, or tin plating.

3.3. PC Boards

A. Material and Thickness

1. Board material will be glass epoxy (FR-4, G-10).
2. Board thickness shall be 0.75 mm [.030 in.] minimum for all socket sizes except for 12P which is used in a 1.27 mm [.050 in.] minimum thick pc board.

Contact the Product Information number listed at the bottom of page 1 for suitability of other board materials or thicknesses.

B. PC Board Hole Dimensions

The socket holes in the pc board must be precisely drilled to ensure proper placement and optimum performance of the socket. The drilled holes must be on 2.54 mm [.100 in.] centerlines (minimum). The dimensions provided in Figure 2 must be observed when preparing a pc board for AUGAT HOLTITE Sockets.

CAUTION Holes should be drilled from the component insertion side of the pc board, whenever possible, to avoid creating drill-exit burrs on the press-fit portion of the through-hole.

CAUTION Finished hole tolerances should NOT be maintained by drilling over-sized holes and then plating down to the correct size, because plating alone will not create the compressive forces necessary to retain the socket over time and temperature ranges. Drilling undersized holes may introduce problems such as excessive socket insertion forces, board warpage, and crazing around the hole.

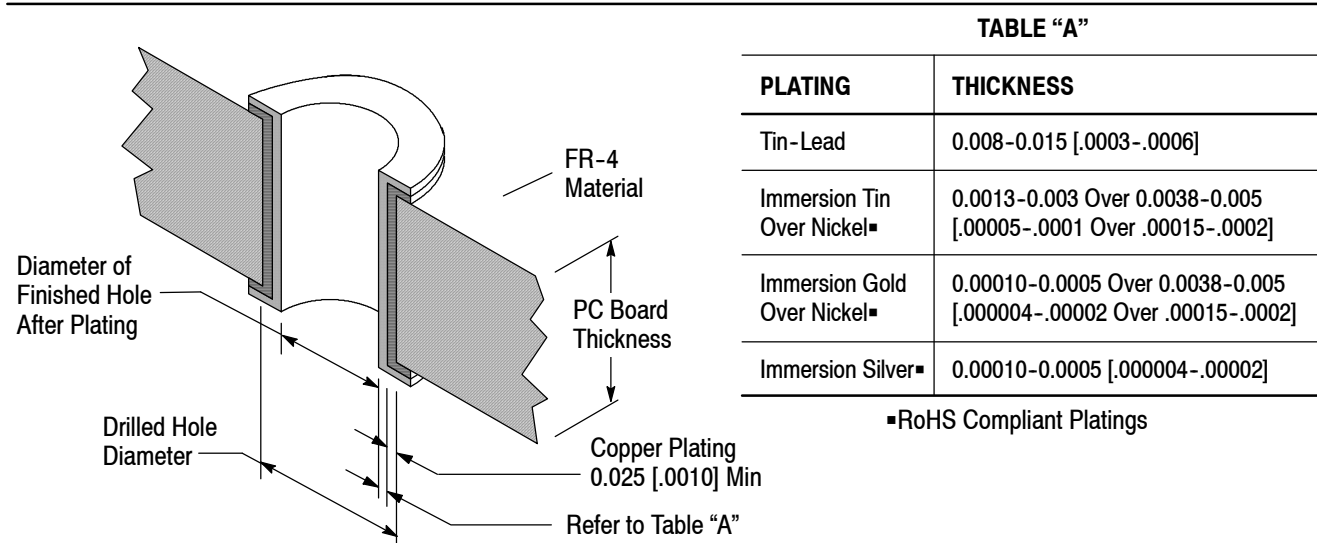

SERIES SIZE	SOCKET DIAMETER	PC BOARD THICKNESS (MIN)	DRILLED HOLE DIAMETER	FINISHED HOLE DIAMETER	VERTICAL PROFILE DIMENSION (MAX)
5P	1.12 ±0.01 [.0440 ±.0005]	0.75 [.030]	1.15 [.0453]	1.04 ±0.05 [.041 ±.002]	2.54 [.100]
6P	1.59 ±0.01 [.0625 ±.0005]	0.75 [.030]	1.61 [.0635]	1.47 ±0.05 [.058 ±.002]	3.56 [.140]
8P	1.59 ±0.01 [.0625 ±.0005]	0.75 [.030]	1.61 [.0635]	1.47 ±0.05 [.058 ±.002]	3.56 [.140]
12P	2.18 ±0.01 [.0860 ±.0005]	1.27 [.050]	2.22 [.0875]	2.08 ±0.05 [.082 ±.002]	4.06 [.160]
14P	1.17 ±0.01 [.0460 ±.0005]	0.75 [.030]	1.15 [.0453]	1.09 ±0.05 [.043 ±.002]	2.54 [.100]
27P	1.12 ±0.01 [.0440 ±.0005]	0.75 [.030]	1.15 [.0453]	1.04 ±0.05 [.041 ±.002]	2.54 [.100]

Figure 2

3.4. Lead Size/Socket Selection

The appropriate AUGAT HOLTITE Socket is selected based on the cross-section size of the leads to be inserted. The diameter of a round lead or the diagonal of a rectangular lead determines the appropriate socket. The table in Figure 3 lists which socket should be used for certain common lead sizes.

RECOMMENDED LEAD SIZE (For Leads Being Inserted Into the AUGAT HOLTITE Sockets)						
Type	5P	6P	8P	12P	14P	27P
ROUND	0.41-0.53 [.016-.021]	0.51-0.76 [.020-.030]	0.64-0.89 [.025-.035]	0.89-1.14 [.035-.045]	0.41-0.53 [.016-.021]	0.41-0.53 [.016-.021]
RECTANGULAR	0.28 x 0.46 ±0.05 [.011 x 0.18 ±.002]	---	0.64 Sq. [.025] Sq.	---	0.28 x 0.46 ±0.05 [.011 x 0.18 ±.002]	0.28 x 0.46 ±0.05 [.011 x 0.18 ±.002]

Figure 3

3.5. Socket Insertion

A. Hole Size Inspection

Using the red NO-GO gage, part number 5-1437514-1, end of the tool provided in the AUGAT HOLTITE Printed Wiring Contact Kit, check to ensure the hole dimensions are correct. If not, rework may be necessary or socket selection may need to be re-checked.

B. Insertion

Sockets are inserted into the pc board using a spring loaded hand tool, a pneumatic hand tool system, flat-rock press-in tooling, or commercially available vibratory/vacuum systems using fully automatic machines. Two different tips may be used for socket insertion into the pc board. The blue tip is used for the 5P, 14P, and 27P series sockets. The other insertion tip is white and is used for the 6P, 8P, and 12P series sockets. Refer to Section 5, TOOLING for specific related tooling part numbers.

3.6. Checking Installed Socket

Once the socket is installed, verification may be made to a correct installation according to the information and dimensions provided in Figures 2 and 4.

A. Referee Test

Inspection may reveal that some of the hole diameters are at the high limit of the tolerance. If this marginal condition occurs, a "referee test" should be performed to determine if the holes are suitable for 5P AUGAT HOLTITE Socket insertion.

Selectively load the sockets into the suspect holes and perform a push-out test using an adequate axial force gauge (e.g., a hand held CHATILLON Force Gauge). Force should be applied to the socket fingers only in an axial direction. Socket retention forces will vary with each application due to differences in socket population density, substrate materials, and number of PC layers. The minimum acceptable push-out force for all 5P AUGAT HOLTITE Sockets is [4 lbs.] (conforming to MIL-S-83505/6).

B. Insertion Verification

TE suggests verifying that the sockets have been loaded into all of the desired locations. This procedure could be accomplished visually or with any type of available automatic non-contacting inspection system.

For visual inspection, place a light source under the pc board and examine the holes from above. A small point of light indicates the socket is present. A large point of light indicates the socket may be missing. The light pattern may be compared to a chart showing socket locations.

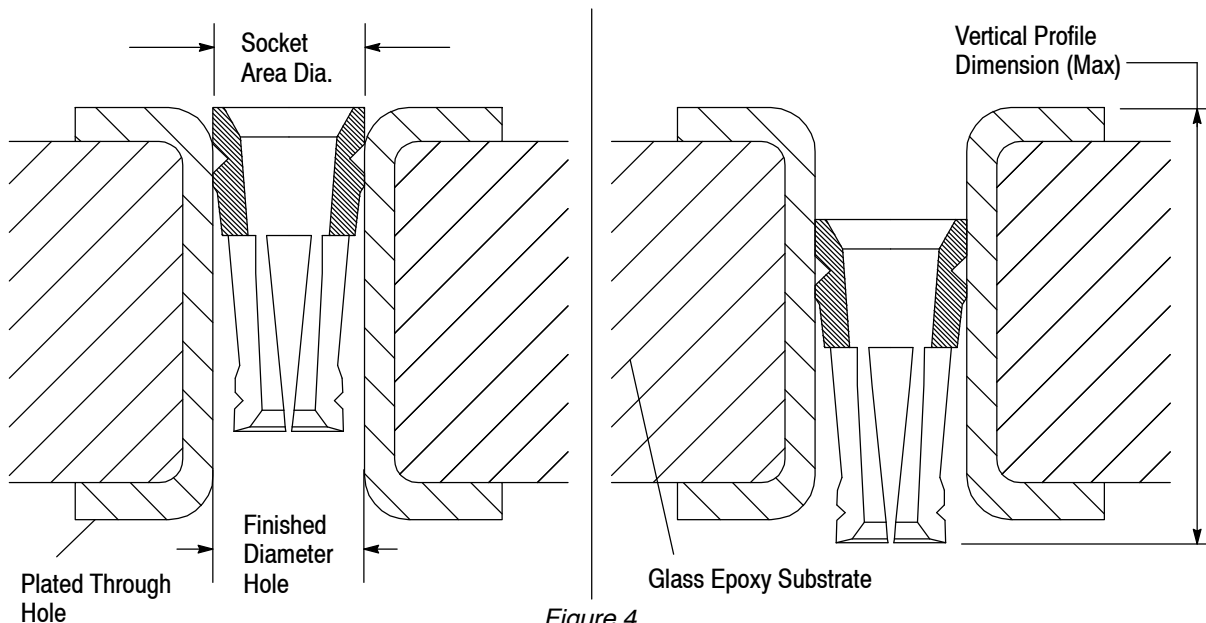

Figure 4

CHATILLON is a trademark

For the alternate method, use an opaque inspection template drilled in a pattern matching the socket locations. There should be no large points of light with the template in place. A loading mask used in conjunction with a mass loading machine will serve this purpose.

3.7. Wave Soldering Consideration

Both AUGAT HOLTITE Sockets and soldered components may be loaded on a pc board. However, either the AUGAT HOLTITE Sockets or their respective plated through holes must be masked to avoid being filled with solder during wave soldering. If the socket can be contained within the pc board, it may be loaded first, and then masked with heat-resistant tape or liquid solder mask prior to soldering to other components. If the socket would protrude through the pc board, the appropriate plated through holes should be masked and wave soldering performed first. Then, the masking is to be removed, and the AUGAT HOLTITE Sockets may be installed. See Figure 5.

SOCKET LENGTH					
5P	6P	8P	12P	14P	27P
2.39 [.094]	3.45 [.136]	3.45 [.136]	3.96 [.156]	2.39 [.094]	2.39 [.094]

Figure 5

3.8. Repair/Replacement

If a socket has been damaged, it must be removed and replaced with a new one. In order to remove a damaged socket, lay the circuit board flat, circuit fingers up on a suitable backing material such as a dense foam board or pad. Place a drill blank on top of the socket fingers, making sure it is properly aligned, and tap it gently with a small hammer until it releases from the pc board. See Figure 6.

TYPE	5P, 14P, 27P	6P, 8P	12P
DRILL BLANK	(No. 62) 0.97 [.038]	(No. 54) 1.40 [.055]	(No. 47) 1.99 [.078]

Figure 6

It may be necessary, if the socket fingers are damaged, to break off the individual finger elements before removing the socket barrel using the previous technique. Installation of a single replacement socket can then be accomplished.

4. QUALIFICATIONS

These sockets are Qualified to MIL-S-83505/6D. However, they are not required to be Recognized by Underwriters Laboratories Inc. (UL); or Certified to CSA International.

5. TOOLING

TE has existing tooling and tooling concepts for applying these sockets. Part numbers of available tooling and the applicable instructional material for each is provided in Figure 7.

- **PC Board Support**

A pc board support must be used to prevent bowing of the pc board during insertion of the sockets. It should have a flat surface with holes or a channel large enough to receive the sockets during installation.

- **Hand Tool**

The insertion portion of the tool is designed to remove the sockets from their respective carrier cards and selectively insert them into the plated-through hole on the pc board. Individual pressing and seating is then accomplished using the correct insertion tip and hand tool.

- **Pneumatic Hand Tool System**

The pneumatic tooling system is designed to individually seat the sockets after they have been inserted into the plated-through hole on the pc board. The tip of the pneumatic hand tool is inserted into the socket and the impact button is depressed. The socket is accurately seated into the plated-through hole. Pressure adjustments and variable tip sizes on the pneumatic hand tool allow this system to work with any size socket.

- **Power Units**

A power unit is an automatic or semi-automatic device used to assist in the application of a product. Power unit includes the power source used to supply the force or power to an applicator.

- **Flat-Rock Tooling**

Flat-rock press-in tooling may be used for mass insertion of the sockets into the plated-through holes on the pc board. Removable carrier strips on 2.54 mm [.100 in.] centerlines may be used with this type of mass insertion. Flat-rock press-in tooling is customer designed.

- **Vibratory/Vacuum System**

Commercially available, fully automatic mass loading machines which will accommodate a vibratory/vacuum system may be used for application of this product. The assembly table (1437513-1) and backup board (1437513-3) may be used in conjunction with the mass loading machine.

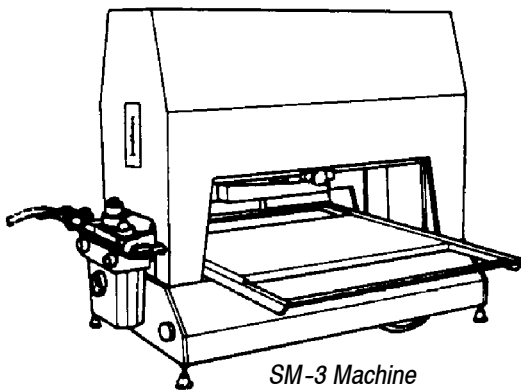

*SM-3 Machine
814700-[]
(409-5626)*

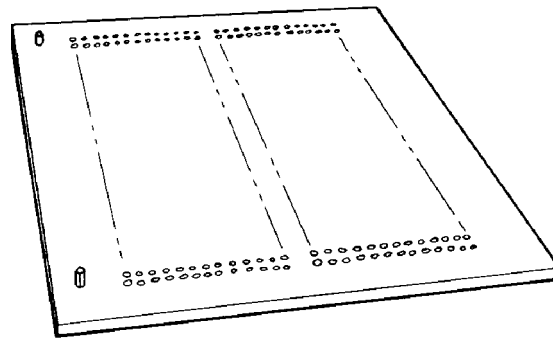

*PC Board Support Fixture
(Customer Supplied)*

*Typical Pneumatic
Arbor
Frame Assembly
91112-3*

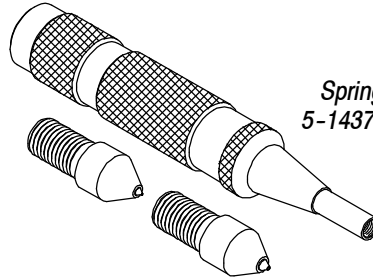
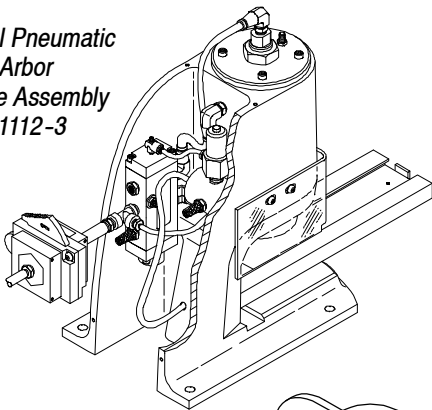

*Spring Loaded Hand Tool
5-1437514-3, 5-1437514-5,
5-1437514-7*

*Typical Manual Arbor
Frame Assemblies
58024-1, 91085-2*

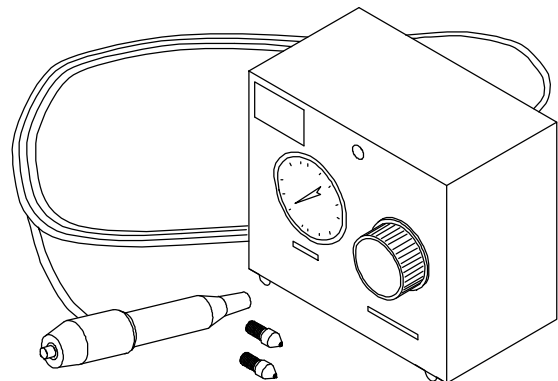
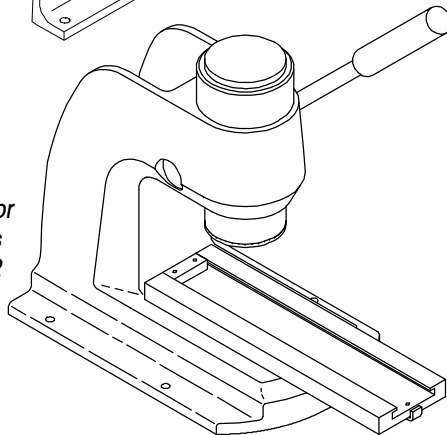

*Pneumatic Hand
Tool System
5-1437514-8*

Figure 7

6. VISUAL AID

Figure 8 shows a typical application of an AUGAT HOLTITE Socket. This illustration should be used by production personnel to ensure a correctly applied product. Applications which DO NOT appear correct should be inspected using the information in the preceding pages of this specification and in the instructional material shipped with the product.

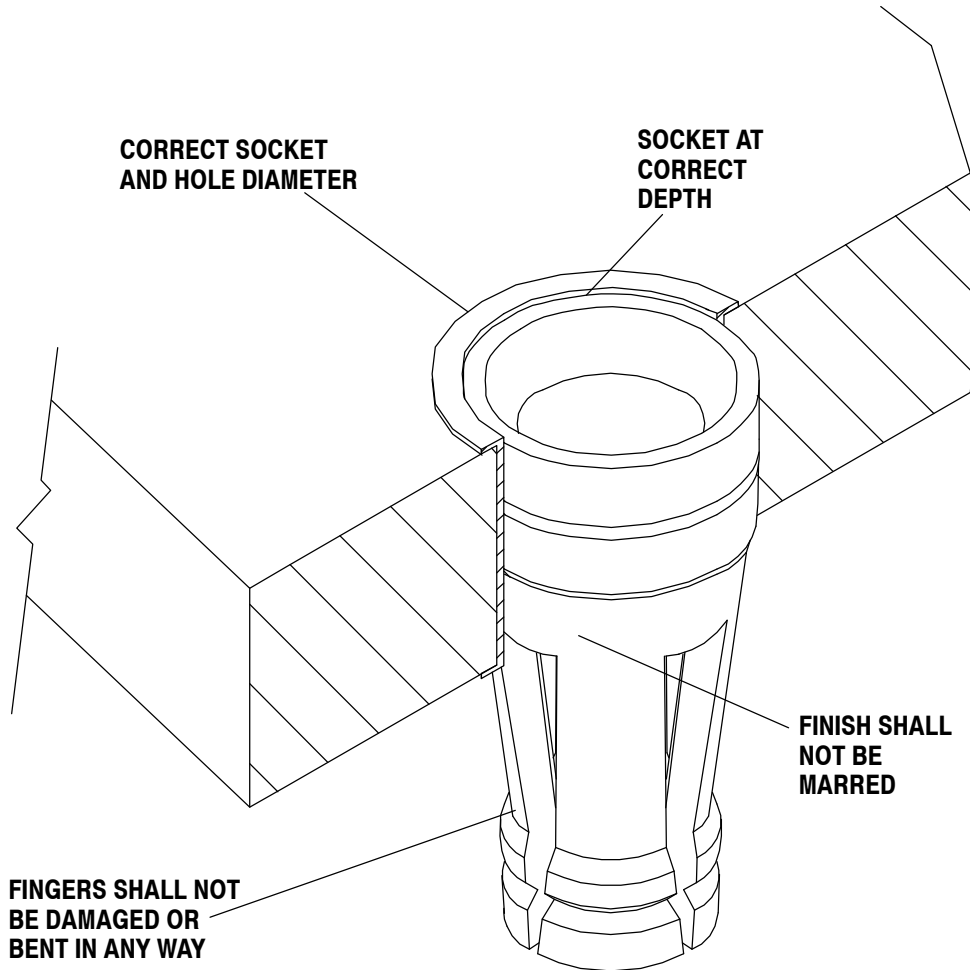

FIGURE 8. VISUAL AID



Компания «ЭлектроПласт» предлагает заключение долгосрочных отношений при поставках импортных электронных компонентов на взаимовыгодных условиях!

Наши преимущества:

- Оперативные поставки широкого спектра электронных компонентов отечественного и импортного производства напрямую от производителей и с крупнейших мировых складов;
- Поставка более 17-ти миллионов наименований электронных компонентов;
- Поставка сложных, дефицитных, либо снятых с производства позиций;
- Оперативные сроки поставки под заказ (от 5 рабочих дней);
- Экспресс доставка в любую точку России;
- Техническая поддержка проекта, помощь в подборе аналогов, поставка прототипов;
- Система менеджмента качества сертифицирована по Международному стандарту ISO 9001;
- Лицензия ФСБ на осуществление работ с использованием сведений, составляющих государственную тайну;
- Поставка специализированных компонентов (Xilinx, Altera, Analog Devices, Intersil, Interpoint, Microsemi, Aeroflex, Peregrine, Syfer, Eurofarad, Texas Instrument, Miteq, Cobham, E2V, MA-COM, Hittite, Mini-Circuits, General Dynamics и др.);

Помимо этого, одним из направлений компании «ЭлектроПласт» является направление «Источники питания». Мы предлагаем Вам помощь Конструкторского отдела:

- Подбор оптимального решения, техническое обоснование при выборе компонента;
- Подбор аналогов;
- Консультации по применению компонента;
- Поставка образцов и прототипов;
- Техническая поддержка проекта;
- Защита от снятия компонента с производства.



Как с нами связаться

Телефон: 8 (812) 309 58 32 (многоканальный)

Факс: 8 (812) 320-02-42

Электронная почта: org@eplast1.ru

Адрес: 198099, г. Санкт-Петербург, ул. Калинина, дом 2, корпус 4, литера А.