



The Future of Analog IC Technology®

MP2013A

40V, 150mA, Low-Quiescent Current Linear Regulator

DESCRIPTION

The MP2013A is a low-power, linear regulator that supplies power to systems with high-voltage batteries. It includes a wide 2.5V to 40V input range, low-dropout voltage and low-quiescent-supply current. The low-quiescent current and low-dropout voltage allow operation at extremely low-power levels. The MP2013A is ideal for low-power microcontrollers and battery-powered equipment.

The MP2013A provides a wide variety of fixed, output-voltage options: 1.8V, 1.9V, 2.3V, 2.5V, 3.0V, 3.3V, 3.45V, and 5.0V, and it provides an adjustable output option (from 1.215V to 15V).

The regulator output current is internally limited; the device is protected against over-load and over-temperature conditions.

The MP2013A includes thermal shutdown (TSD) and current-limiting fault protection. It is available in QFN6 (2mmx2mm), and QFN8 (3mmx3mm) packages.

FEATURES

- 2.5V to 40V Input Range
- 3.3µA Quiescent-Supply Current
- Stable with Low-Value Output Ceramic Capacitor (> 0.47 µF)
- 150mA Specified Current
- 620mV Dropout at 150mA Load
- Available in Fixed and Adjustable Output (1.215 V to 15 V) Versions
- ±2% Output Accuracy
- Specified Current Limit
- Thermal Shutdown
- -40°C to +125°C Specified Junction-Temperature Range
- Available in QFN6 (2x2mm), and QFN8 (3x3mm) Packages

APPLICATIONS

- Industrial/Automotive Applications
- Portable/Battery-Powered Equipment
- Ultra Low-Power Microcontrollers
- Cellular Handsets
- Medical Imaging

All MPS parts are lead-free and adhere to the RoHS directive. For MPS green status, please visit MPS website under Products, Quality Assurance page. "MPS" and "The Future of Analog IC Technology" are registered trademarks of Monolithic Power Systems, Inc.

TYPICAL APPLICATION

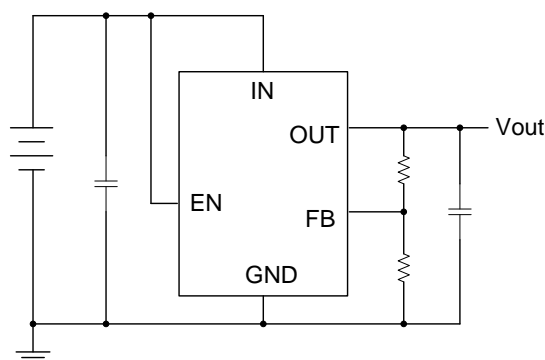

Output Adjustable Version



Output Fixed Version

ORDERING INFORMATION

Part Number*	Package	Top Marking
MP2013AGQ	QFN8(3mmx3mm)	<i>See Below</i>
MP2013AGQ-18	QFN8(3mmx3mm)	
MP2013AGQ-25	QFN8(3mmx3mm)	
MP2013AGQ-33	QFN8(3mmx3mm)	
MP2013AGQ-5	QFN8(3mmx3mm)	

* For Tape & Reel, add suffix -Z (e.g. MP2013AGQ-33-Z)

PACKAGE REFERENCE



TOP MARKING

AJDY
LLL

AJD: part code of MP2013AGQ;
Y: year code;
LLL: lot number;

AZBY
LLL

AZB: part code of MP2013AGQ-18;
Y: year code;
LLL: lot number;

AQNY
LLL

AQN: part code of MP2013AGQ-25;
Y: year code;
LLL: lot number;

AJZY
LLL

AJZ: part code of MP2013AGQ-33;
Y: year code;
LLL: lot number;

ALJY
LLL

ALJ: part code of MP2013AGQ-5;
Y: year code;
LLL: lot number;

ORDERING INFORMATION

Part Number*	Package	Top Marking
MP2013AGG	QFN6(2mmx2mm)	See Below
MP2013AGG-33	QFN6(2mmx2mm)	
MP2013AGG-5	QFN6(2mmx2mm)	

* For Tape & Reel, add suffix -Z (e.g. MP2013AGG-33-Z)

PACKAGE REFERENCE



TOP MARKING

—
CDY
LLL

CD: part code of MP2013AGG;
Y: year code;
LLL: lot number;

—
CPY
LLL

CP: part code of MP2013AGG-33;
Y: year code;
LLL: lot number;

—
FRY
LLL

FR: part code of MP2013AGG-5;
Y: year code;
LLL: lot number;

ABSOLUTE MAXIMUM RATINGS ⁽¹⁾

IN, EN	-0.3V to +42V
OUT	-0.3V to +17V
FB	-0.3V to +6V
Lead Temperature	260°C
Storage Temperature.....	-65°C to +150°C
Continuous Power Dissipation (T _A = +25°C) ⁽²⁾	
QFN8(3mmx3mm)	2.08W
QFN6(2mmx2mm)	1.25W

ESD SUSCEPTIBILITY ⁽³⁾

HBM (Human Body Model)	2kV
MM (Machine Model).....	200V

Recommended Operating Conditions ⁽⁴⁾

Supply Voltage V _{IN}	2.5V to 40V
Output Voltage V _{OUT}	1.215V to 15V
Operating Junction Temp. (T _J). -40°C to +125°C	

Thermal Resistance ⁽⁵⁾	θ_{JA}	θ_{JC}
QFN6(2mmx2mm)	80	16 ... °C/W
QFN8(3mmx3mm)	48	11 ... °C/W

Notes:

- 1) Exceeding these ratings may damage the device.
- 2) The maximum allowable power dissipation is a function of the maximum junction temperature T_J (MAX), the junction-to-ambient thermal resistance θ_{JA}, and the ambient temperature T_A. The maximum allowable continuous power dissipation at any ambient temperature is calculated by P_D (MAX) = (T_J (MAX)-T_A)/θ_{JA}. Exceeding the maximum allowable power dissipation will cause excessive die temperature, and the regulator will go into thermal shutdown. Internal thermal shutdown circuitry protects the device from permanent damage.
- 3) Devices are ESD sensitive. Handling precaution recommended.
- 4) The device is not guaranteed to function outside of its operating conditions.
- 5) Measured on JESD51-7, 4-layer PCB.

ELECTRICAL CHARACTERISTICS
 $T_J = +25^{\circ}\text{C}$, $V_{EN}=V_{IN}$, $I_{OUT} = 1\text{mA}$, $C_{OUT} = 1\mu\text{F}$, unless otherwise noted.

Parameter	Symbol	Condition	Min	Typ	Max	Units	
Input Voltage	V_{IN}		2.5		40	V	
Output-Voltage Range	V_{OUT}		1.215		15	V	
GND Current	I_{GND}	MP2013AGQ, $0 < I_{OUT} < 1\text{mA}$, $V_{IN}=2.5\text{V to }40\text{V}$, $V_{OUT}=5\text{V}(V_{IN} \geq 6\text{V})$ or $\text{FB}(V_{IN} < 6\text{V})$		3.3	9	μA	
		MP2013AGQ, $1\text{mA} < I_{OUT} < 30\text{mA}$, $V_{IN}=2.5\text{V to }15\text{V}$, $V_{OUT}=5\text{V}(V_{IN} \geq 6\text{V})$ or $\text{FB}(V_{IN} < 6\text{V})$		11	22		
		MP2013AGQ, $30\text{mA} < I_{OUT} < 150\text{mA}$, $V_{IN}=6\text{V}$, $V_{OUT}=5\text{V}$		32	50		
		MP2013AGQ-18, $0\text{mA} < I_{OUT} < 1\text{mA}$, $V_{IN}=3.5\text{V to }40\text{V}$		4.4	10	μA	
		MP2013AGQ-18, $1\text{mA} < I_{OUT} < 30\text{mA}$, $V_{IN}=3.5\text{V to }15\text{V}$		15	25		
		MP2013AGQ-18, $30\text{mA} < I_{OUT} < 150\text{mA}$, $V_{IN}=3.5\text{V}$		35	50		
		MP2013AGQ-25 $0\text{mA} < I_{OUT} < 1\text{mA}$, $V_{IN}=3.5\text{V to }40\text{V}$		4.4	10	μA	
		MP2013AGQ-25, $1\text{mA} < I_{OUT} < 30\text{mA}$, $V_{IN}=3.5\text{V to }15\text{V}$		15	25		
		MP2013AGQ-25, $30\text{mA} < I_{OUT} < 150\text{mA}$, $V_{IN}=3.5\text{V}$		35	50		
		MP2013AGQ-33, $0 < I_{OUT} < 1\text{mA}$, $V_{IN}=4.3\text{V to }40\text{V}$		4.4	10	μA	
		MP2013AGQ-33, $1\text{mA} < I_{OUT} < 30\text{mA}$, $V_{IN}=4.3\text{V to }15\text{V}$		15	25		
		MP2013AGQ-33, $30\text{mA} < I_{OUT} < 150\text{mA}$, $V_{IN}=4.3\text{V}$		35	50		
		MP2013AGQ-5, $0 < I_{OUT} < 1\text{mA}$, $V_{IN}=6\text{V to }40\text{V}$		4.4	8	μA	
		MP2013AGQ-5, $1\text{mA} < I_{OUT} < 30\text{mA}$, $V_{IN}=6\text{V to }15\text{V}$		15	20		
		MP2013AGQ-5, $30\text{mA} < I_{OUT} < 150\text{mA}$, $V_{IN}=6\text{V}$		35	48		
		MP2013AGG, $0 < I_{OUT} < 1\text{mA}$, $V_{IN}=2.5\text{V to }40\text{V}$, $V_{OUT}=5\text{V}(V_{IN} \geq 6\text{V})$ or $\text{FB}(V_{IN} < 6\text{V})$			3.3	9	μA
		MP2013AGG, $1\text{mA} < I_{OUT} < 30\text{mA}$, $V_{IN}=2.5\text{V to }15\text{V}$, $V_{OUT}=5\text{V}(V_{IN} \geq 6\text{V})$ or $\text{FB}(V_{IN} < 6\text{V})$			11	22	
		MP2013AGG, $30\text{mA} < I_{OUT} < 150\text{mA}$, $V_{IN}=6\text{V}$, $V_{OUT}=5\text{V}$			32	50	

ELECTRICAL CHARACTERISTICS (continued)
 $T_J = +25^\circ\text{C}$, $V_{EN}=V_{IN}$, $I_{OUT} = 1\text{mA}$, $C_{OUT} = 1\mu\text{F}$, unless otherwise noted.

Parameter	Symbol	Condition	Min	Typ	Max	Units
GND Current	I_{GND}	MP2013AGG-33, $0 < I_{OUT} < 1\text{mA}$, $V_{IN}=4.3\text{V}$ to 40V		4.4	10	μA
		MP2013AGG-33, $1\text{mA} < I_{OUT} < 30\text{mA}$, $V_{IN}=4.3\text{V}$ to 15V		15	25	
		MP2013AGG-33, $30\text{mA} < I_{OUT} < 150\text{mA}$, $V_{IN}=4.3\text{V}$		35	50	
		MP2013AGG-5, $0 < I_{OUT} < 1\text{mA}$, $V_{IN}=6\text{V}$ to 40V		4.4	10	μA
		MP2013AGG-5, $1\text{mA} < I_{OUT} < 30\text{mA}$, $V_{IN}=6\text{V}$ to 15V		15	25	
		MP2013AGG-5, $30\text{mA} < I_{OUT} < 150\text{mA}$, $V_{IN}=6\text{V}$		35	50	
Shutdown Supply Current	I_{SHDN}	$V_{EN}=0$, $V_{IN}=2.5$ to 40V		3	9	μA
Load Current Limit	I_{LIMIT}	MP2013AGQ, MP2013AGQ-5, MP2013AGG, MP2013AGG-5, $V_{OUT} = 0\text{V}$, $V_{IN}=6\text{V}$ to 15V	180	270	400	mA
		MP2013AGQ-33, MP2013AGG-33, $V_{OUT} = 0\text{V}$, $V_{IN}=4.3\text{V}$ to 15V				
		MP2013AGQ-18, MP2013AGQ-25, $V_{OUT}=0\text{V}$, $V_{IN}=3.5\text{V}$ to 15V				
Output-Voltage Accuracy		MP2013AGQ-18, $V_{IN}=2.8\text{V}$, $I_{OUT}=0$	1.773	1.8	1.827	V
		MP2013AGQ-25, $V_{IN}=3.5\text{V}$, $I_{OUT}=0$	2.45	2.5	2.55	
		MP2013AGQ-33, MP2013AGG-33, $V_{IN}=4.3\text{V}$, $I_{OUT}=0$	3.234	3.3	3.366	
		MP2013AGQ-5, MP2013AGG-5, $V_{IN}=6\text{V}$, $I_{OUT}=0$	4.9	5	5.1	
FB Voltage	V_{FB}	$V_{OUT}=FB$, $V_{IN}=5\text{V}$, $I_{OUT}=0$	1.191	1.215	1.239	V
Dropout Voltage $V_{IN}=V_{OUT(NOM)}-0.1\text{V}$	$V_{DROPOUT}$	MP2013AGQ-18, $I_{OUT}=100\text{mA}$, $V_{OUT(NOM)}=1.8\text{V}$		700	950	mV
		MP2013AGQ-25, $I_{OUT}=150\text{mA}$, $V_{OUT(NOM)}=2.5\text{V}$		700	900	
		MP2013AGQ-33, $I_{OUT} = 150\text{mA}$, $V_{OUT(NOM)} = 3.3\text{V}$		700	850	
		MP2013AGQ-5, MP2013AGQ, MP2013AGG-5, MP2013AGG, $I_{OUT} = 150\text{mA}$, $V_{OUT(NOM)} = 5\text{V}$		600	850	
		MP2013AGG-33, $I_{OUT} = 150\text{mA}$, $V_{OUT(NOM)} = 3.3\text{V}$		700	1000	

ELECTRICAL CHARACTERISTICS (continued)
 $T_J = +25^{\circ}\text{C}$, $V_{EN}=V_{IN}$, $I_{OUT} = 1\text{mA}$, $C_{OUT} = 1\mu\text{F}$, unless otherwise noted.

Parameter	Symbol	Condition	Min	Typ	Max	Units
FB Input Current	I_{FB}	MP2013A-18, MP2013A-25, MP2013A-33 and MP2013A-5, $V_{FB} = 1.3\text{V}$, $V_{IN}=6\text{V}$, OUT Floating	0.9	1.3	1.6	μA
		MP2013A, $V_{FB} = 1.3\text{V}$, $V_{IN}=6\text{V}$, OUT Floating	-50	0	50	nA
Line Regulation ⁽⁶⁾		$V_{IN} = 2.5$ to 40V , $I_{OUT} = 1\text{mA}$, OUT = FB		0.01	0.05	%/V
Load Regulation ⁽⁷⁾		MP2013AGQ-18, $I_{OUT}=100\mu\text{A}$ to 150mA , $V_{IN}= 2.8\text{V}$ to 6V		0.005	0.01	%mA
		MP2013AGQ-25, $I_{OUT}=100\mu\text{A}$ to 150mA , $V_{IN}=3.5\text{V}$ to 6V				
		MP2013AGQ-33, MP2013AGG-33, $I_{OUT} = 100\mu\text{A}$ to 150mA , $V_{IN}=4.3\text{V}$ to 6V				
		MP2013AGQ, MP2013AGQ-5, MP2013AGG, MP2013AGG-5, $I_{OUT} = 100\mu\text{A}$ to 150mA , $V_{IN}= 6\text{V}$				
Output Voltage PSRR ⁽⁸⁾		100Hz, $C_{IN} = 100\text{pF}$, $C_{OUT} = 4.7\mu\text{F}$ $I_{OUT}=10\text{mA}$, $V_{IN}=6\text{V}$		58		dB
		1kHz, $C_{IN} = 100\text{pF}$, $C_{OUT} = 4.7\mu\text{F}$ $I_{OUT}=10\text{mA}$, $V_{IN}=6\text{V}$		41		dB
		100kHz, $C_{IN} = 100\text{pF}$, $C_{OUT} = 4.7\mu\text{F}$ $I_{OUT}=10\text{mA}$, $V_{IN}=6\text{V}$		55		dB
Startup Response Time		MP2013AGQ, MP2013AGG, $I_{OUT}= 100\text{mA}$, $C_{OUT}=6.8\mu\text{F}$, $V_{OUT}= 5\text{V}$			3	ms
		MP2013AGQ-18, $I_{OUT}=10\text{mA}$, $C_{OUT}=6.8\mu\text{F}$, $V_{OUT}=1.8\text{V}$			1.1	
		MP2013AGQ-25, $I_{OUT}=10\text{mA}$, $C_{OUT}=6.8\mu\text{F}$, $V_{OUT}=2.5\text{V}$			1.5	
		MP2013AGQ-33, MP2013AGG-33, $I_{OUT}= 10\text{mA}$, $C_{OUT}=6.8\mu\text{F}$, $V_{OUT}= 3.3\text{V}$			1.8	
		MP2013AGQ-5, MP2013AGG-5, $I_{OUT}= 10\text{mA}$, $C_{OUT}=6.8\mu\text{F}$, $V_{OUT}= 5\text{V}$			3	

ELECTRICAL CHARACTERISTICS (continued)
 $T_J = +25^{\circ}\text{C}$, $V_{EN}=V_{IN}$, $I_{OUT} = 1\text{mA}$, $C_{OUT} = 1\mu\text{F}$, unless otherwise noted.

Parameter	Symbol	Condition	Min	Typ	Max	Units
EN Rising Threshold	EN_{TH_R}	$V_{IN}=2.5\text{V to }40\text{V}$	1.38	1.48	1.58	V
EN Falling Threshold	EN_{TH_F}	$V_{IN}=2.5\text{V to }40\text{V}$	1.18	1.26	1.38	V
EN Input Current	I_{EN}	$V_{EN} = 0\text{V or }15\text{V}$, $V_{IN}=2.5\text{V to }40\text{V}$			0.1	μA
Thermal Shutdown ⁽⁸⁾	T_{SD}		150	165		$^{\circ}\text{C}$
Thermal Shutdown Hysteresis ⁽⁸⁾	ΔT_{SD}			20		$^{\circ}\text{C}$

Notes:

$$6) \text{ Line Regulation} = \frac{|V_{OUT[V_{IN(MAX)}]} - V_{OUT[V_{IN(MIN)}]}|}{(V_{IN(MAX)} - V_{IN(MIN)}) \times V_{OUT(NOM)}} \times (\%/V)$$

$$7) \text{ Load Regulation} = \frac{|V_{OUT[I_{OUT(MAX)}]} - V_{OUT[I_{OUT(MIN)}]}|}{(I_{OUT(MAX)} - I_{OUT(MIN)}) \times V_{OUT(NOM)}} \times (\%/mA)$$

8) Derived from bench characterization. Not tested in production.

TYPICAL CHARACTERISTICS



TYPICAL PERFORMANCE CHARACTERISTICS

$C_{IN} = 1\mu F$, $C_{OUT} = 4.7\mu F$, $V_{OUT}=5V$, $T_A = +25^\circ C$, unless otherwise noted

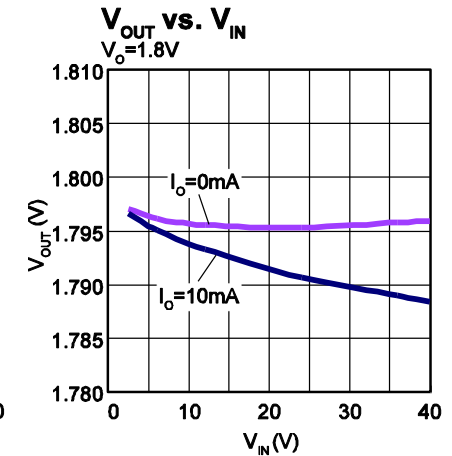
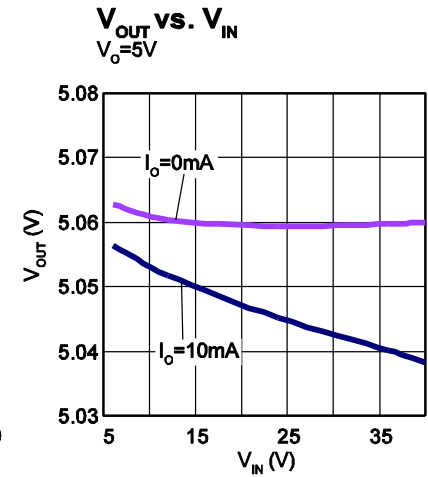
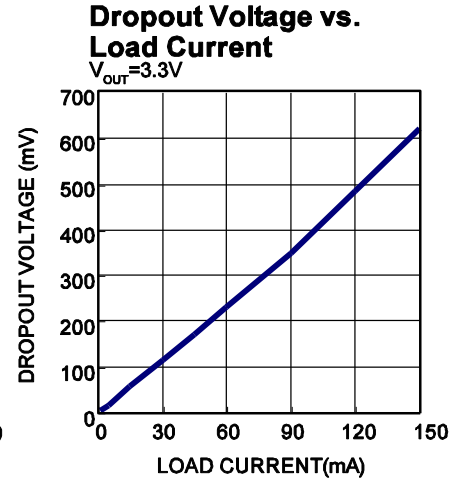

TYPICAL PERFORMANCE CHARACTERISTICS (continued)
 $C_{IN} = 1\mu F, C_{OUT} = 4.7\mu F, V_{OUT} = 5V, T_A = +25^\circ C$, unless otherwise noted

 V_{OUT} vs. V_{IN}
 $V_O = 1.215V$

PSRR vs. Frequency
 $V_{IN1} = V_{IN2} = 6V, I_O = 10mA, C_{IN} = 100pF$

Load Transient
 $V_{IN} = 12V, I_{OUT} = 8mA-150mA$

Line Transient
 $V_{IN} = 6V-7V, I_{OUT} = 150mA$

Startup Through V_{IN}
 $V_{IN} = 12V, I_{OUT} = 150mA$

Shutdown Through V_{IN}
 $V_{IN} = 12V, I_{OUT} = 150mA$

Short-Circuit Entry
 $V_{IN} = 12V, I_{OUT} = 0mA$ to short circuit

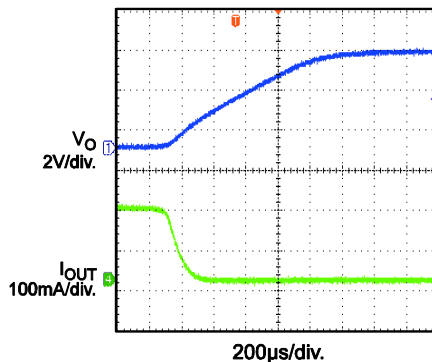
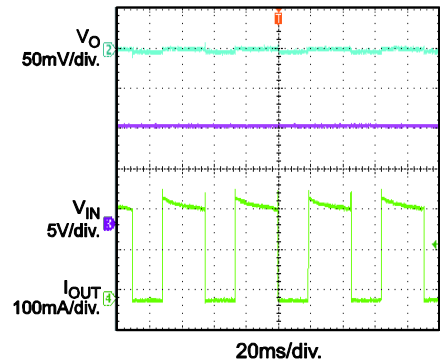
Short-Circuit Recovery
 $V_{IN} = 12V$, short circuit to $I_{OUT} = 0mA$

Short-Circuit Steady State
 $V_{IN} = 12V$

PIN FUNCTIONS

Pin # QFN6 (2mmx2mm)	Pin # QFN8 (3mmx3mm)	Name	Description
1	1	IN	Input Voltage. Connect IN to a 2.5V to 40V supply.
2	2	EN	Enable. A logic low on EN shuts down the IC; logic high starts it up. Connect EN to IN for automatic startup.
3, exposed pad	4, exposed pad	GND	Ground. The exposed pad and GND must be connected to the same ground plane.
4	5	FB	Feedback Input. FB is regulated to 1.215V nominally. Connect to an external resistive divider between OUT and GND to set output voltage. For a fixed-output version, FB can float.
6	8	OUT	Regulated Output Voltage. Only a low-value ceramic capacitor ($\geq 0.47\mu\text{F}$) on output is required for stability.
5	3, 6, 7	NC	No Connection. May be left open or tied to ground for improved thermal performance.

OPERATION

The MP2013A is a linear regulator that supplies power to systems with high-voltage batteries. It includes a wide 2.5V to 40V input range, low-dropout voltage and low-quiescent-supply current.

The MP2013A provides a wide variety of fixed, output-voltage options: 1.8V, 1.9V, 2.3V, 2.5V, 3.0V, 3.3V, 3.45V, and 5.0V; and it provides an adjustable output option (from 1.215V to 15V).

The adjustable output option delivers an output that is adjustable from 1.215V to 15V with a simple resistor divider. It uses external feedback, allowing the user to set the output voltage with an external resistor divider. The typical FB voltage is 1.215V.

The IC enters shutdown mode when EN is low. In shutdown mode, the pass transistor, control circuitry, reference, and all biases turn off, reducing the supply current to $<3\mu\text{A}$. Connect EN to IN for automatic startup.

The regulator output current is internally limited. The device is protected against over-load and over-temperature conditions.

The peak-output current is limited to around 270mA, which exceeds the 150mA recommended continuous-output current.

When the junction temperature is too high, the thermal sensor sends a signal to the control logic that shuts down the IC. The IC restarts when the temperature has cooled sufficiently.

The maximum power-output current is a function of the package's maximum power dissipation for a given temperature.

The maximum power dissipation is dependent on the thermal resistance of the case and the circuit board, the temperature difference between the die junction and the ambient air, and the rate of air flow. The GND and exposed pad must be connected to the ground plane for proper dissipation.



Figure 1: Functional Block Diagram

APPLICATION INFORMATION

Component Selection

Setting the Output Voltage

Set the output voltage of the MP2013A by using a resistor divider as shown:

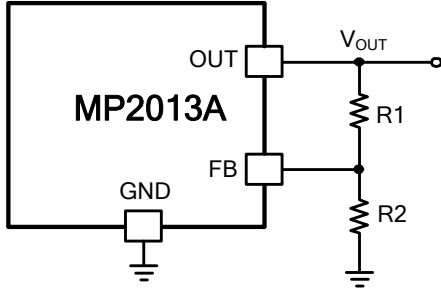

Figure 2: FB Resistor Divider to Set V_{OUT}

Choose $R2=1M\Omega$ to maintain a $1.215\mu A$ minimum load. Calculate the value for $R1$ using the following equation:

$$R1 = R2 \times \left(\frac{V_{OUT}}{1.215V} - 1 \right)$$

For fixed output version, V_{OUT} also can be adjusted by adding external resistor divider. Just note to take internal FB resistor divider into consideration when choose external divider.



Figure 3: FB Divider of Fixed Output Version

When $R2$ is selected, $R1$ can be calculated by below equation:

$$R1 = \frac{R1_IN}{\frac{1.215 \times R1_IN \times (R2 + R2_IN)}{(V_{OUT} - 1.215) \times R2 \times R2_IN} - 1}$$

The internal FB resistor dividers for different fixed output versions please see below table.

Table 1: Internal FB Resistor Divider

Fixed Output Voltage (V)	R1_IN (MΩ)	R2_IN (MΩ)
1.8	0.482	1
2.5	1.058	1
3.3	1.716	1
5	3.117	1

Table 2 is an example of external FB divider to get various output voltages on fixed 3.3V output version.

Table 2 –3.3V Fixed Output Version External FB Divider

V_{OUT} (V)	R1 (kΩ)	R2 (kΩ)
11	84.5	10
8.5	61.9	10
8	57.6	10
6.5	44.2	10
5	31.6	10

Setting VIN UVLO

To prevent part from operating at an insufficient power supply voltage, a resistor divider as show in figure 3 can be used to adjust the VIN UVLO point.

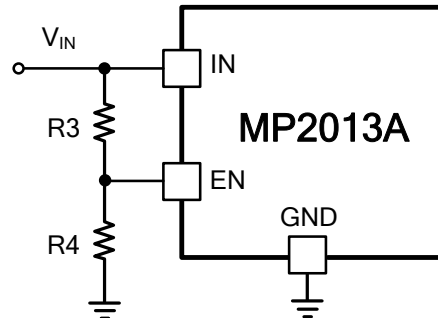

Figure 4: EN Resistor Divider to Set VIN UVLO

If choose $R3$ first, then $R4$ can be calculated by below equation:

$$R4 = R3 \times \frac{EN_{TH_L}}{V_{IN_UVLO} - EN_{TH_L}}$$

Where EN_{TH_L} is the EN falling threshold 1.26V. To limit the divider current, high value resistors are recommended. For example, if V_{IN_UVLO} is set at 4.5V, $R3=2M\Omega$ and $R4=778k\Omega$ can be used.

Input Capacitor

For proper operation, place a ceramic capacitor (C1) between $1\mu\text{F}$ and $10\mu\text{F}$ of dielectric type X5R or X7R between the input pin and ground. Larger values in this range will help improve line transient response.

Output Capacitor

For stable operation, use a ceramic capacitor (C3) of type X5R or X7R between $1\mu\text{F}$ and $10\mu\text{F}$. Larger values in this range will help improve load transient response and reduce noise. Output capacitors of other dielectric types may be used, but are not recommended as their capacitance can deviate greatly from their rated value over temperature.

To improve load transient response, add a small ceramic (X5R, X7R or Y5V dielectric) 22nF feed forward capacitor in parallel with R1. The feed forward capacitor is not required for stable operation.

Output Noise

The MP2013A will exhibit noise on the output during normal operation. This noise is negligible for most applications. However, in applications that include analog-to-digital converters (ADCs) of more than 12 bits, one needs to consider the ADC's power supply rejection specifications. The feed forward capacitor C2 across R1 will significantly reduce the output noise.

External Reverse Voltage Protection

In some situations, e.g. a backup battery is connected as MP2013A load, the output voltage may be held up while the input is either pulled to ground, pulled to some intermediate voltage or is floating. Thus, the output voltage is higher than input voltage. Since the MP2013A PMOS pass element has a body diode, a current will conduct from the output to input and is not internally limited. It's possible that the IC will be damaged by this unlimited reverse current. To avoid this, it's recommended to place an external diode at input like below.



PCB Layout Guide

PCB layout is very important to achieve good regulation, ripple rejection, transient response and thermal performance. It is highly recommended to duplicate EVB layout for optimum performance.

If change is necessary, please follow these guidelines and take figure 5 for reference.

- 1) Input and output bypass ceramic capacitors are suggested to be put close to the IN Pin and OUT Pin respectively.
- 2) Ensure all feedback connections are short and direct. Place the feedback resistors and compensation components as close to the chip as possible.
- 3) Connect IN, OUT and especially GND respectively to a large copper area to cool the chip to improve thermal performance and long-term reliability.



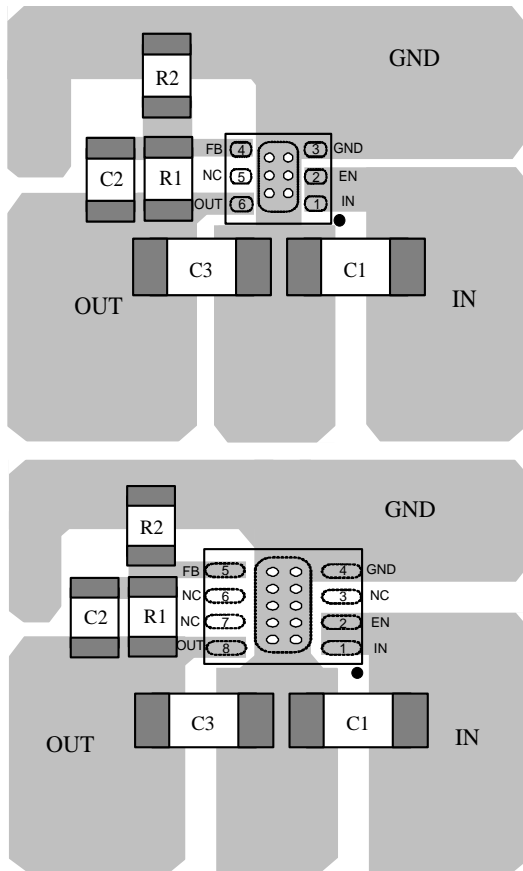

Figure 5: PCB Layout (Top Layer)

Design Example

Below is a design example following the application guidelines for $V_{OUT}=3.3V$ with feedforward cap.

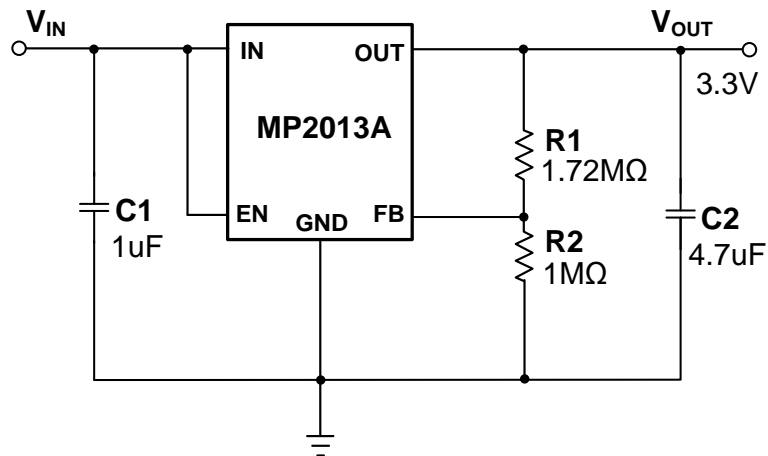
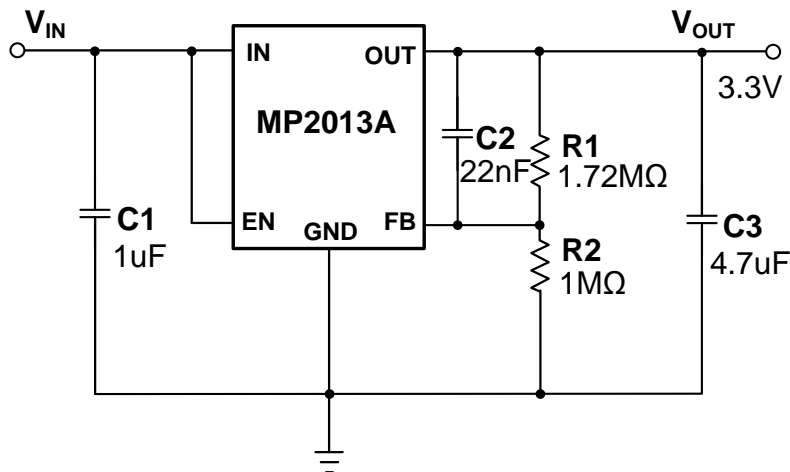
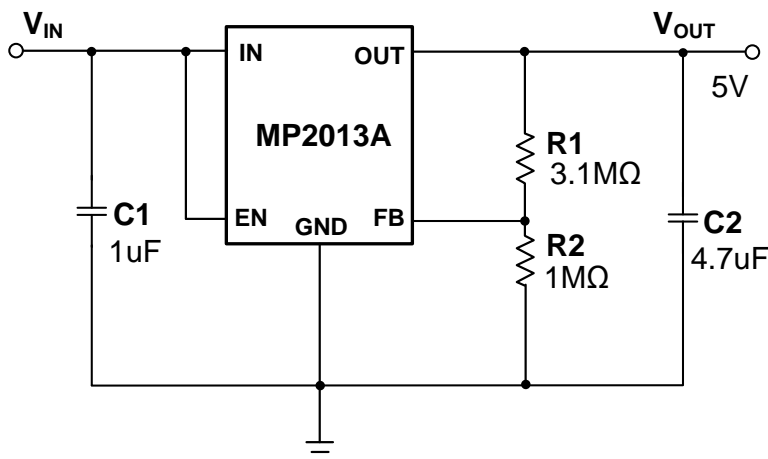
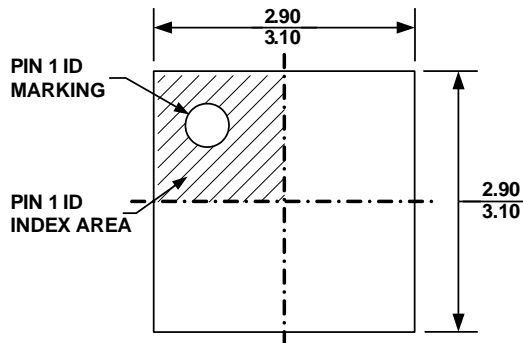

Figure 6: Design Example

TYPICAL APPLICATION CIRCUITS

Figure 7: 3.3V Output Typical Application Circuit

Figure 8: 3.3V Output with Feedforward Capacitor

Figure 9: 5V Output Typical Application Circuit

PACKAGE INFORMATION

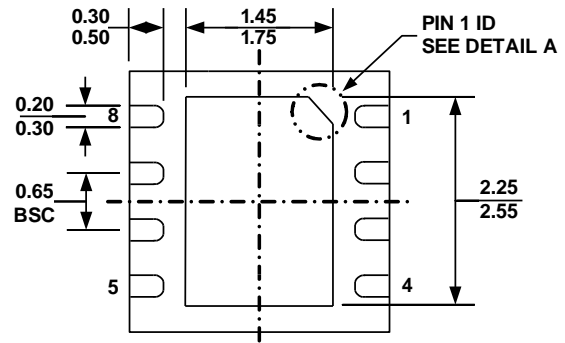
QFN8 (3mmx3mm)



TOP VIEW



BOTTOM VIEW

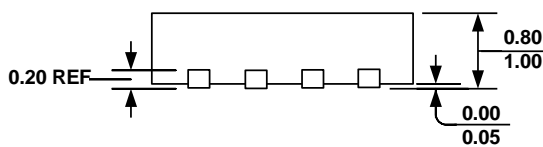

SIDE VIEW

PIN 1 ID OPTION A
0.30x45° TYP.

PIN 1 ID OPTION B
R0.20 TYP.

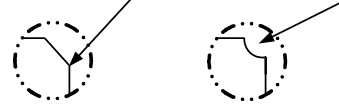

DETAIL A

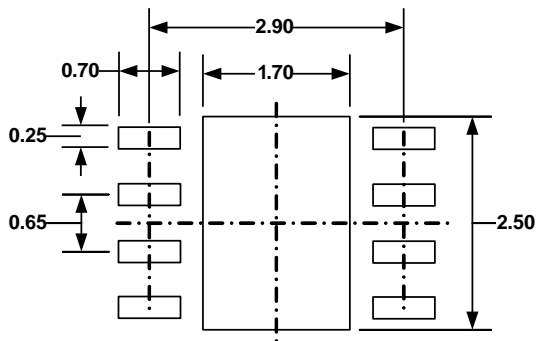

RECOMMENDED LAND PATTERN

NOTE:

- 1) ALL DIMENSIONS ARE IN MILLIMETERS
- 2) EXPOSED PADDLE SIZE DOES NOT INCLUDE MOLD FLASH
- 3) LEAD COPLANARITY SHALL BE 0.10 MILLIMETER MAX
- 4) JEDEC REFERENCE IS MO-229, VARIATION VEEC-2.
- 5) DRAWING IS NOT TO SCALE

QFN6 (2mmx2mm)



TOP VIEW



BOTTOM VIEW



SIDE VIEW

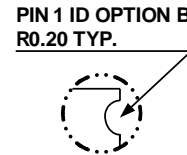
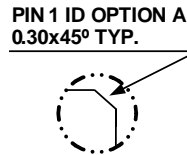

DETAIL A

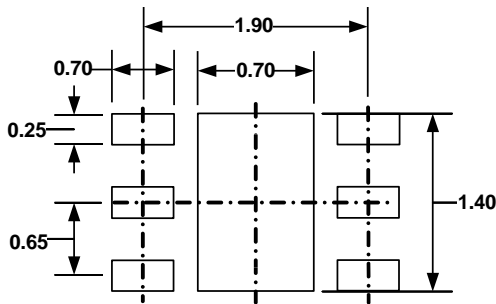

RECOMMENDED LAND PATTERN

NOTE:

- 1) ALL DIMENSIONS ARE IN MILLIMETERS
- 2) EXPOSED PADDLE SIZE DOES NOT INCLUDE MOLD FLASH
- 3) LEAD COPLANARITY SHALL BE 0.10 MILLIMETER MAX
- 4) JEDEC REFERENCE IS MO-229, VARIATION VCCC.
- 5) DRAWING IS NOT TO SCALE

NOTICE: The information in this document is subject to change without notice. Please contact MPS for current specifications. Users should warrant and guarantee that third party Intellectual Property rights are not infringed upon when integrating MPS products into any application. MPS will not assume any legal responsibility for any said applications.



Компания «ЭлектроПласт» предлагает заключение долгосрочных отношений при поставках импортных электронных компонентов на взаимовыгодных условиях!

Наши преимущества:

- Оперативные поставки широкого спектра электронных компонентов отечественного и импортного производства напрямую от производителей и с крупнейших мировых складов;
- Поставка более 17-ти миллионов наименований электронных компонентов;
- Поставка сложных, дефицитных, либо снятых с производства позиций;
- Оперативные сроки поставки под заказ (от 5 рабочих дней);
- Экспресс доставка в любую точку России;
- Техническая поддержка проекта, помощь в подборе аналогов, поставка прототипов;
- Система менеджмента качества сертифицирована по Международному стандарту ISO 9001;
- Лицензия ФСБ на осуществление работ с использованием сведений, составляющих государственную тайну;
- Поставка специализированных компонентов (Xilinx, Altera, Analog Devices, Intersil, Interpoint, Microsemi, Aeroflex, Peregrine, Syfer, Eurofarad, Texas Instrument, Miteq, Cobham, E2V, MA-COM, Hittite, Mini-Circuits, General Dynamics и др.);

Помимо этого, одним из направлений компании «ЭлектроПласт» является направление «Источники питания». Мы предлагаем Вам помощь Конструкторского отдела:

- Подбор оптимального решения, техническое обоснование при выборе компонента;
- Подбор аналогов;
- Консультации по применению компонента;
- Поставка образцов и прототипов;
- Техническая поддержка проекта;
- Защита от снятия компонента с производства.



Как с нами связаться

Телефон: 8 (812) 309 58 32 (многоканальный)

Факс: 8 (812) 320-02-42

Электронная почта: org@eplast1.ru

Адрес: 198099, г. Санкт-Петербург, ул. Калинина, дом 2, корпус 4, литера А.