

PSE1000-PFC

1000 Watts

PFC Front End

Total Power: 1000 W
of Outputs: Single
Output: 390 V



Special Features

- 1000 W output power
- Unity power factor correction
- 3.5" x 2.4" x 1"
- 119 Watts per cubic inch
- Industrial safety
- -40 °C to 85 °C
- High efficiency: 94% typical
- Negative enable function
- Output OTP, OVP and power limit
- Current sharing and monitoring
- MIL-STD-810F for shock and vibration

Compliance

- EMI Class B (with external filter)
- EN61000 lunity
- RoHS 2

Safety

- UL 60950-1
508/1598/1433
60601-1 EO 3
- cUL 60950-1
- TUV 60950-1
60601
- CB Scheme Report/Cert

Electrical Specifications

Input	
Input range:	90 - 264 Vac (Operating) 115/230 Vac (Nominal)
Frequency:	47 - 63 Hz
Inrush current:	≤ 50 A peak at 230 Vac @ 25 deg C (with external resistor from INRUSH pin to OUTPUT -)
Power factor:	> 0.97 typical
Input current:	10.3 A RMS max input current, at 115 Vac
Hold up time:	16 ms minimum, at 115 Vrms AC input, full load with 680 uF/450 Vdc electrolytic capacitor
Efficiency:	> 94% typical at full load / 230 VAC nominal
ON/OFF power switch	Remote negative enable
Isolation:	PRI-Chassis 1500 Vac

Electrical Specifications

Output		
Output rating	390 Vdc	180 - 264 Vac
Set point		
Total regulation range	380 V to 400 Vdc 5 Vsb ± 1%	With 680 uF / 450 V electrolytic capacitor
Rated load	1000 W maximum	No derating up to 85 °C, Vin > 100 Vac
Minimum load	Main output @ 0.0 A	No loss of regulation
Output noise (PARD)	< 50 V max p-p	Full load at 680 uF / 450 V capacitor
Output voltage overshoot		No overshoot/undershoot outside the regulation band during ON or OFF cycle
Transient response	< 300 µSec	50% load step @ 1 A/µs Step load valid between 10% to 100% of output rating Recovery time to within 1% of set point at onset of transient
Max units in parallel	Up to 10	
Remote sense		Compensation up to 500 mV
Output isolation		Standard per safety requirements
Forced load sharing	To within 10% of all shared outputs	Analog sharing control
Overload protection (OCP)	140% to 160%	
Overvoltage protection (OVP)	110% to 135%	Latched until AC line recycle
Overtemp protection	102 - 107 °C baseplate temperature	Shut down and automatically restart when fault is removed

Environmental Specifications

Operating temperature:	-40 °C to +85 °C baseplate temperature
Storage temperature	-40 °C to +100 °C
Humidity	10 to 100% non-condensing operating
Altitude	Operating - 13,000 feet, derating 1 degree C per 1000 feet above 10,000 feet Storage - 50,000 feet
Shock	MIL-STD-810F 516.5,
Vibration	MIL-STD-810F 514.5, Cat, IEC68-2-6

Ordering Information

Model Number	Output	Nominal Output Voltage Set Point	Current		Output Ripple P/P 0-50 deg C	Max Continuous Power	Combined Line/ Load Regulation
			Min	Max			
PSE1000PFC	390 V	390 V	0 A	2.82 A	< 50 V	1000	2.5%

Mechanical Drawing

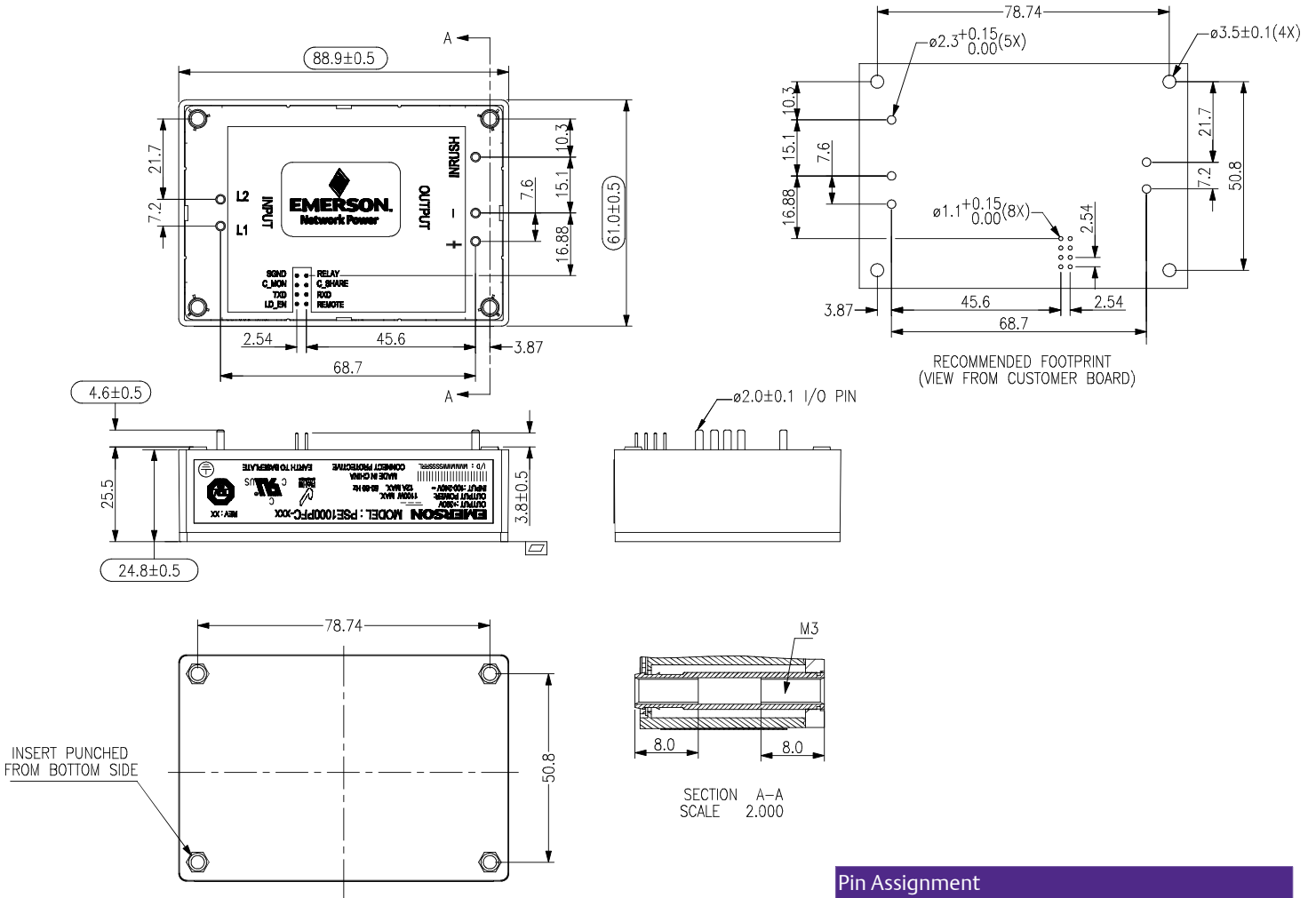

Pin Assignment	
Signal Type	Description
L1	AC input
L2	AC input
S GND	Signal ground
C. Mon	Current monitoring
TXD	Digital communication
LD EN	Load Enable
Relay	
C. Share	Current Share
RXD	Digital communication
Remote	Remote ON/OFF
INRUSH	Limit Inrush Current
Output +	DC Output +
Output -	DC Output -

Miscellaneous Specifications

Burn-In

100% Burn-in at 45 °C, at 80 - 90% load. Duration of burn-in determined by Quality Assurance Procedures

MTBF

The power supply has a minimum MTBF of 300K hours using the Bell core 332, issue 6 specification @ 25 °C and 40 °C, ambient, at full load. With the power supply installed in a system in a 25 °C ambient environment and operating at full load, capacitor life shall be 10 years, minimum for ALL electrolytic capacitors contained within this power supply. The power supply shall demonstrate a MTBF level of > 500,000 hours.

Quality Assurance

Full QAV testing shall be conducted in accordance with Emerson Network Power Standards with reports available upon request.

Warranty

Emerson Network Power shall warrant the power supply to be free of defects in materials and workmanship for a minimum period of **three years** from the date of shipment, when operated within specifications. The warranty shall be fully transferable to the end owner of the equipment powered by the supply.

Americas

5810 Van Allen Way
Carlsbad, CA 92008
USA
Telephone: +1 760 930 4600
Facsimile: +1 760 930 0698

Europe (UK)

Waterfront Business Park
Merry Hill, Dudley
West Midlands, DY5 1LX
United Kingdom
Telephone: +44 (0) 1384 842 211
Facsimile: +44 (0) 1384 843 355

Asia (HK)

14/F, Lu Plaza
2 Wing Yip Street
Kwun Tong, Kowloon
Hong Kong
Telephone: +852 2176 3333
Facsimile: +852 2176 3888

For global contact, visit:

www.Emerson.com/EmbeddedPower
techsupport.embeddedpower@emerson.com

While every precaution has been taken to ensure accuracy and completeness in this literature, Emerson Network Power assumes no responsibility, and disclaims all liability for damages resulting from use of this information or for any errors or omissions.

Emerson Network Power.
The global leader in enabling
business-critical continuity.

- AC Power
- Connectivity
- DC Power
- Embedded Computing
- **Embedded Power**
- Monitoring
- Outside Plant
- Power Switching & Controls
- Precision Cooling
- Racks & Integrated Cabinets
- Services
- Surge Protection

EmersonNetworkPower.com

Emerson and the Emerson Network Power logo are trademarks of Emerson Electric Co.
©2013 Emerson Electric Co.
All rights reserved.



Компания «ЭлектроПласт» предлагает заключение долгосрочных отношений при поставках импортных электронных компонентов на взаимовыгодных условиях!

Наши преимущества:

- Оперативные поставки широкого спектра электронных компонентов отечественного и импортного производства напрямую от производителей и с крупнейших мировых складов;
- Поставка более 17-ти миллионов наименований электронных компонентов;
- Поставка сложных, дефицитных, либо снятых с производства позиций;
- Оперативные сроки поставки под заказ (от 5 рабочих дней);
- Экспресс доставка в любую точку России;
- Техническая поддержка проекта, помощь в подборе аналогов, поставка прототипов;
- Система менеджмента качества сертифицирована по Международному стандарту ISO 9001;
- Лицензия ФСБ на осуществление работ с использованием сведений, составляющих государственную тайну;
- Поставка специализированных компонентов (Xilinx, Altera, Analog Devices, Intersil, Interpoint, Microsemi, Aeroflex, Peregrine, Syfer, Eurofarad, Texas Instrument, Miteq, Cobham, E2V, MA-COM, Hittite, Mini-Circuits, General Dynamics и др.);

Помимо этого, одним из направлений компании «ЭлектроПласт» является направление «Источники питания». Мы предлагаем Вам помощь Конструкторского отдела:

- Подбор оптимального решения, техническое обоснование при выборе компонента;
- Подбор аналогов;
- Консультации по применению компонента;
- Поставка образцов и прототипов;
- Техническая поддержка проекта;
- Защита от снятия компонента с производства.



Как с нами связаться

Телефон: 8 (812) 309 58 32 (многоканальный)

Факс: 8 (812) 320-02-42

Электронная почта: org@eplast1.ru

Адрес: 198099, г. Санкт-Петербург, ул. Калинина, дом 2, корпус 4, литера А.