

# DN SERIES-NEW D SUBMINIATURE INTERFACE CONNECTORS

## General

The DN series are compact, rectangular multi-contact connectors developed to meet the demand for smaller and slimmer electronic equipment. 2.54 mm grid contact position and Direct dip soldering on PCB enable

high density circuit designing at reduced cost. Aluminum die-cast shell and Metallic shell are shielded to prevent from Electro-Magnetic interference. 20, 26, 36 and 50 way available.

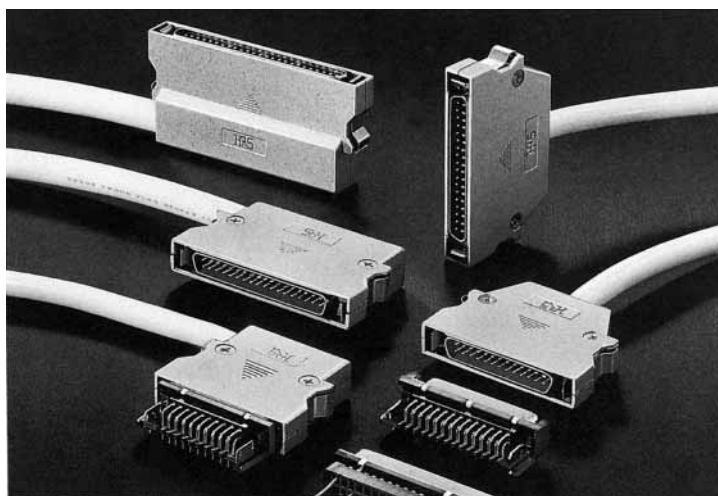

## Features

1. 2.54 mm grid contact position enable high density circuit designing.
2. Stable quality due to the contact design based on our field-proven SM series (D sub-connector).
3. One-touch lock system ensures perfect operation.
4. The cover case uses a thin, low-back compact design that meets the needs of high density mounting. It can be mounted between 17.78 millimeters (700mil) substrates.
5. The cover case is made of aluminum diecast to shield against electromagnetic waves. In a combination with a connector metal shell, the cover case is an ideal solution for noise.
6. Dip soldering connectors are provided with snap clamps for temporarily fixing the connector on the PCB.
7. IDC termination types are for standard 1.27 mm pitch cables, and are available for two types of cables: AWG26 and AWG28.
8. Crimp contact cables from AWG26 through AWG28.
9. Allows you to take out the cable vertically or horizontally, as your application requires.

## Application

Office Automation, Computers, Communications Equipment, Factory Automation, Home Automation and other commercial applications needing high density interconnections.

## Specifications and Material

| Main specifications   |                             |
|-----------------------|-----------------------------|
| Current capacity      | 3A                          |
| Rated voltage         | AC 200V                     |
| Insulation resistance | 5000mΩ or higher at DC 500V |
| Contact resistance    | 20mΩ or less at DC 100mA    |
| Withstand voltage     | 1 minute AC 1000 Vrms       |

| Main materials used |                   |                        |
|---------------------|-------------------|------------------------|
| Shell               | Aluminum dei-cash | Silver coating         |
| Insulator           | PBT*              | Black                  |
| Contacts            | Phosphor bronze   | Selective gold plating |

\*UL94V-0

## Ordering Information

DN 10 — 26 S ( )  
 (1) (2) (3) (4) (8)

DN — 26 — CVE 1  
 (1) (3) (5)

DN 50 — 2628 PC 1  
 (1) (2) (6) (7)

- (1) Series Number: DN
- (2) Type  
 10: Right Angle Dip Type  
 30: IDC Plug Type  
 50: Crimp Type
- (3) No. of Pins: 20, 26, 36 and 50 way
- (4) P: Plug  
 S: Receptacle
- (5) Shell  
 CVE1: Angle Cable Exit Shell  
 CV1: Straight Cable Exit Shell
- (6) Applicable Wire  
 2628: AWG#26 ~ AWG#28
- (7) Type of Contact Pin  
 PC1: Bulk Pin Contact  
 PC2: Chain Pin Contact
- (8) Specification  
 (50): RoHS compliant

## Cable specifications

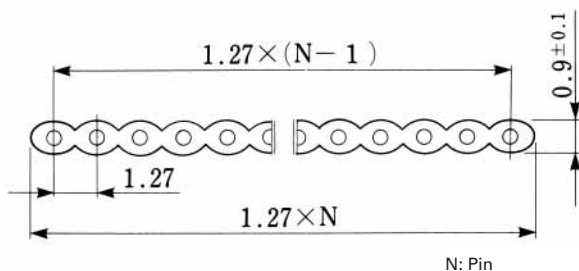

Pin: AWG#28(7/0.127)  
 AWG#26(7/0.16)

## Crimp Pin Housing



DN50-26P

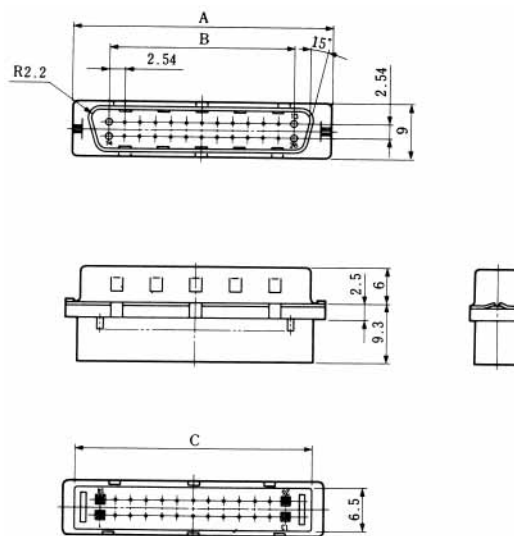

Unit: mm

| HRS No.    | Noof pin | Part No. | A     | B     | C     | RoHS |
|------------|----------|----------|-------|-------|-------|------|
| 225-0016-3 | 20       | DN50-20P | 35.36 | 22.86 | 31.38 | YES  |
| 225-0004-4 | 26       | DN50-26P | 42.98 | 30.48 | 39    |      |
| 225-0005-7 | 36       | DN50-36P | 55.68 | 43.18 | 51.7  |      |
| 225-0006-0 | 50       | DN50-50P | 73.46 | 60.96 | 69.48 |      |

## IDC Plug



DN30-36P (50)

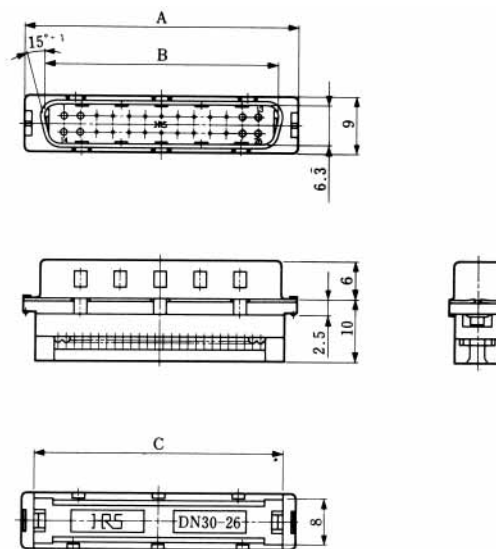

Unit: mm

| HRS No.       | Noof pin | Part No.      | A     | B    | C     | RoHS |
|---------------|----------|---------------|-------|------|-------|------|
| 225-0030-4-50 | 20       | DN30-20P (50) | 35.36 | 29.1 | 31.38 | YES  |
| 225-0029-5-50 | 26       | DN30-26P (50) | 42.98 | 36.7 | 39    |      |
| 225-0027-0-50 | 36       | DN30-36P (50) | 55.68 | 49.4 | 51.7  |      |
| 225-0028-2-50 | 50       | DN30-50P (50) | 73.46 | 67.2 | 69.48 |      |

## Angle Cable Exit Shell



DN-26-CVE1

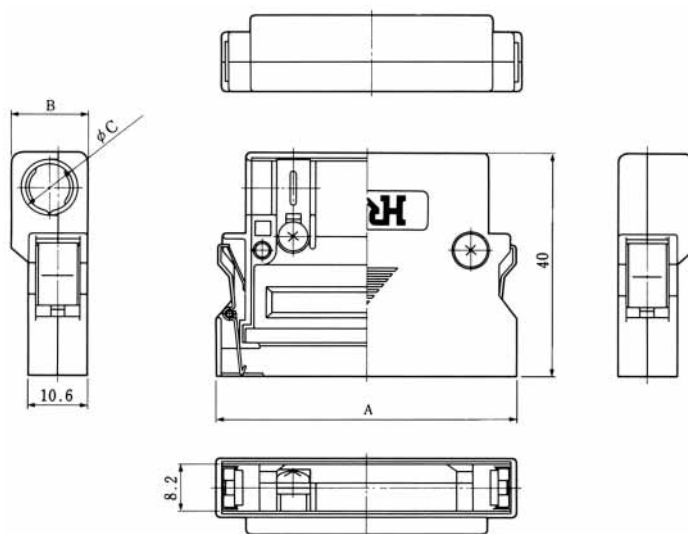

Unit: mm

| HRS No.    | No. of pin | Part No.   | A    | B    | C     | RoHS |
|------------|------------|------------|------|------|-------|------|
| 225-0019-1 | 20         | DN-20-CVE1 | 45.9 | 12.7 | 9     | YES  |
| 225-0020-0 | 26         | DN-26-CVE1 | 53.5 | 13.7 | 9.7   |      |
| 225-0021-3 | 36         | DN-36-CVE1 | 66.2 | 14.2 | 11    |      |
| 225-0022-6 | 50         | DN-50-CVE1 | 84   | 14.2 | 12×13 |      |

## Straight Cable Exit Shell



DN-26-CV1

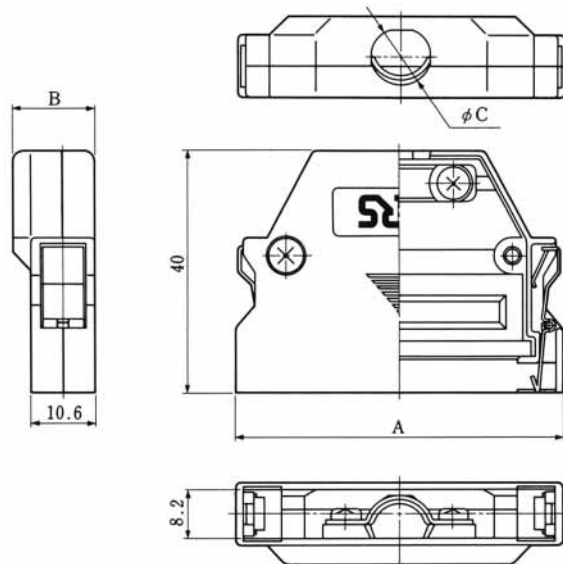

Unit: mm

| HRS No.    | No. of pin | Part No.  | A    | B    | C   | RoHS |
|------------|------------|-----------|------|------|-----|------|
| 225-0031-7 | 20         | DN-20-CV1 | 45.9 | 13.7 | 9   | YES  |
| 225-0024-1 | 26         | DN-26-CV1 | 53.5 | 13.7 | 9.7 |      |
| 225-0025-4 | 36         | DN-36-CV1 | 66.2 | 14.2 | 11  |      |

## Right Angle P.C. Mount Receptacle



DN10-26S (50)

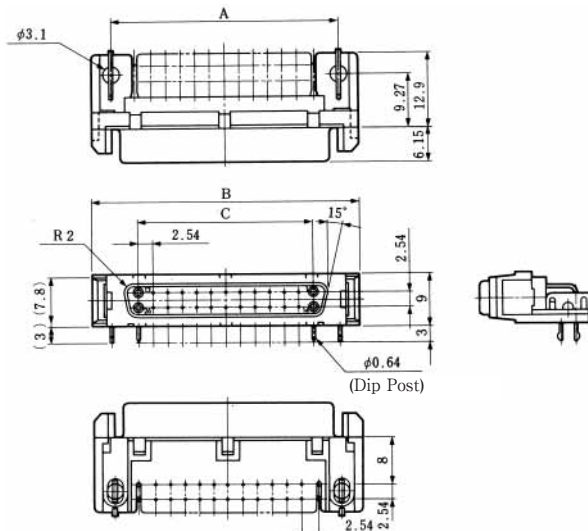

Unit: mm

| HRS No.       | Noof pin | Part No.      | A    | B    | C     | RoHS |
|---------------|----------|---------------|------|------|-------|------|
| 225-0015-0-50 | 20       | DN10-20S (50) | 32   | 38.9 | 22.86 | YES  |
| 225-0001-6-50 | 26       | DN10-26S (50) | 39.6 | 46.5 | 30.48 |      |
| 225-0002-9-50 | 36       | DN10-36S (50) | 52.3 | 59.2 | 43.18 |      |
| 225-0003-1-50 | 50       | DN10-50S (50) | 70.1 | 77   | 60.96 |      |

## PCB Layout

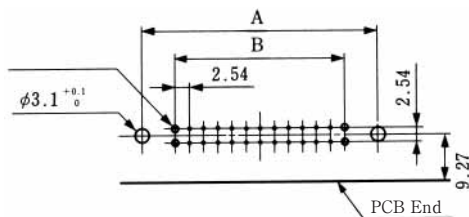

mounting panel thickness 1.6mm

Unit: mm

| Noof pin | 20    | 26    | 36    | 50    |
|----------|-------|-------|-------|-------|
| A        | 32.0  | 39.6  | 52.3  | 70.1  |
| B        | 22.86 | 30.48 | 43.18 | 60.96 |

## Straight P.C. Mount Receptacle

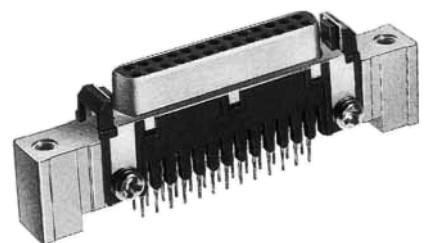

DN20B-26S (50)

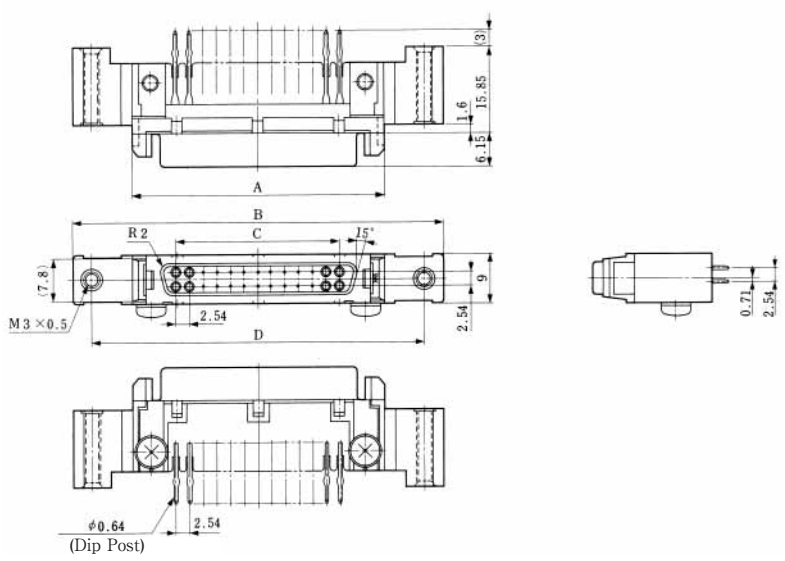

Unit: mm

| HRS No.       | No. of pin | Part No.       | A    | B    | C     | D    | RoHS |
|---------------|------------|----------------|------|------|-------|------|------|
| 225-0045-1-50 | 20         | DN20B-20S (50) | 38.9 | 60.9 | 22.86 | 53.9 | YES  |
| 225-0046-4-50 | 26         | DN20B-26S (50) | 46.5 | 68.5 | 30.48 | 61.5 |      |
| 225-0047-7-50 | 36         | DN20B-36S (50) | 59.2 | 81.2 | 43.18 | 74.2 |      |
| 225-0048-0-50 | 50         | DN20B-50S (50) | 77   | 99   | 60.96 | 92   |      |

## PCB Layout

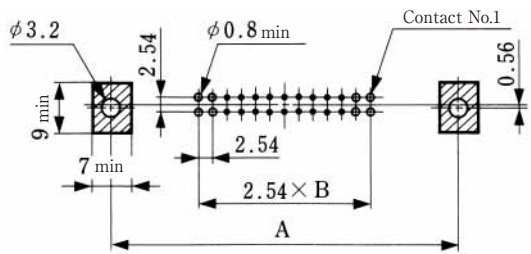

## Panel Cutout

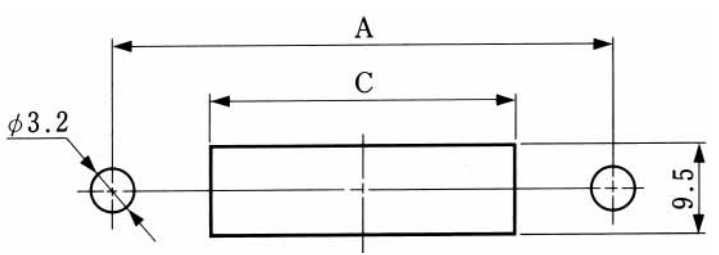

Unit: mm

| No. of pin | A    | B  | C    |
|------------|------|----|------|
| 20         | 53.9 | 9  | 40.9 |
| 26         | 61.5 | 12 | 48.5 |
| 36         | 74.2 | 17 | 61.2 |
| 50         | 92   | 24 | 79   |

- Note:
1. Use a 1.6-mm thick panel
  2. The substrate reference drawing shows the connector-mounting surface. The area marked with [ ] is to be prohibited from entering any pattern.
  3. The substrate and panel are related to each other, with a 0/3.2 mounting hole as the reference point.
  4. The panel is 1.6 millimeters thick.

## Pin Crimp Terminal

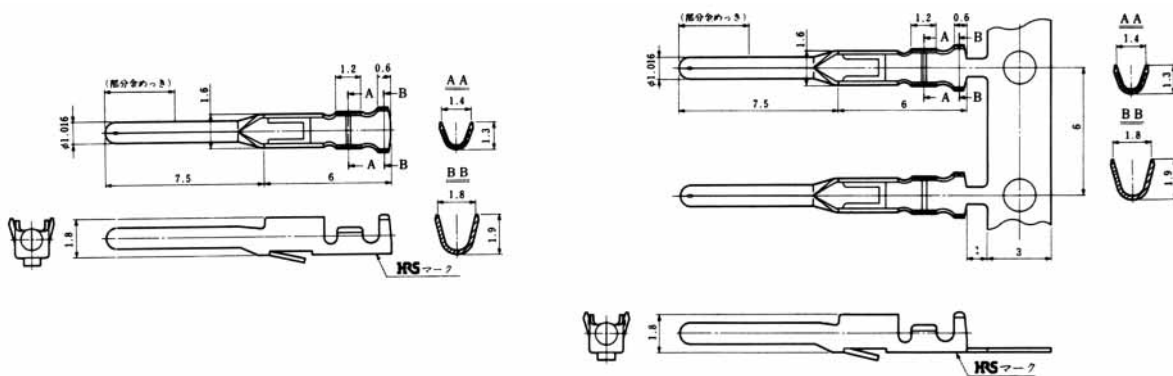

DN50-2628PC1  
(Bulk)

DN50-2628PC2  
(Chain)

Note: Bulk in bags of 100pc. Chain on reels of 1,000pcs

| HRS No.    | Part No.     | Remarks             | RoHS |
|------------|--------------|---------------------|------|
| 225-0007-2 | DN50-2628PC1 | Loose piece contact | YES  |
| 225-0008-5 | DN50-2628PC2 | Strip contact       | YES  |

## Applicable Wire

Applicable wire: AWG No.26 ~ AWG No.28

Outer diameter of applicable wire

Unit: mm

| Way            | 20       | 26       | 36        | 50        |
|----------------|----------|----------|-----------|-----------|
| Outer diameter | Max. 9.0 | Max. 9.7 | Max. 11.0 | Max. 12.0 |

## Tooling (for Crimp Plug)

- CM-105 Crimp Maching

This machine has been carefully designed to meet the many requests for advanced crimping machines that can be used in a wider range of applications. This machine offers easy setup adjustment and applicator mounting. We are confident that the machine will find many applications as an easy-to-use semi-automatic machine for crimping strip contacts.

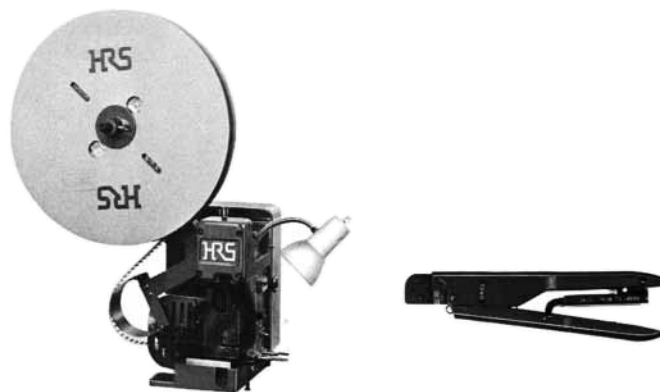

Semi-Auto Machine  
CM-105  
(CL901-0005-4)  
Applicator (Die) 105-DN50  
(CL901-0208-1)

Hand Tool  
DN50-TA2628HC  
(CL250-0101-0)

|              |                                |
|--------------|--------------------------------|
| POWER SOURCE | AC 100V 200W                   |
| TOTAL WEIGHT | 75 kgs                         |
| PERFORMANCE  | 2,000-4,000 crimps per hour    |
| WORK RANGE   | Adaptable to other HIROSE dies |

## Tooling (for IDC Plug)

Hand Press



| HRS No.    | Part No.                                  |
|------------|---|
| 550-0082-2 | Hi-Flex termination press and accessories |

Pressure Block



| HRS No.    | Part No.  |
|------------|-----------|
| 902-0068-0 | DN30-26PB |
| 902-0069-3 | DN30-36PB |
| 902-0143-4 | DN30-20PB |
| 902-0144-7 | DN30-50PB |

Universal Guide Plate

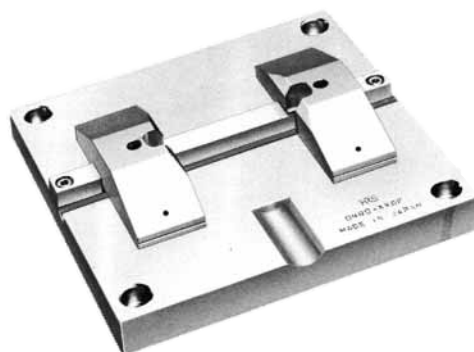

| HRS No.    | Part No.  |
|------------|-----------|
| 902-0067-8 | DN30-XXGP |

## Hi-Flex Termination Press and Accessories

### General

The Hi-Flex termination press and its accessories connect the connectors to the HIF series ribbon cables more securely and quickly.

### Features

1. No incomplete connections. A preventive ratch-type device ensures against misconnections.
2. Prevents damage to connectors during connection. The guide plate works as a stopper to prevent damage to connectors due to connection pressure.
3. Easy to position the connector and cable. The guide plate case guide and cable stopper help positioning.
4. Capable of cable connection at an intermediate point when the cable stopper is removed.

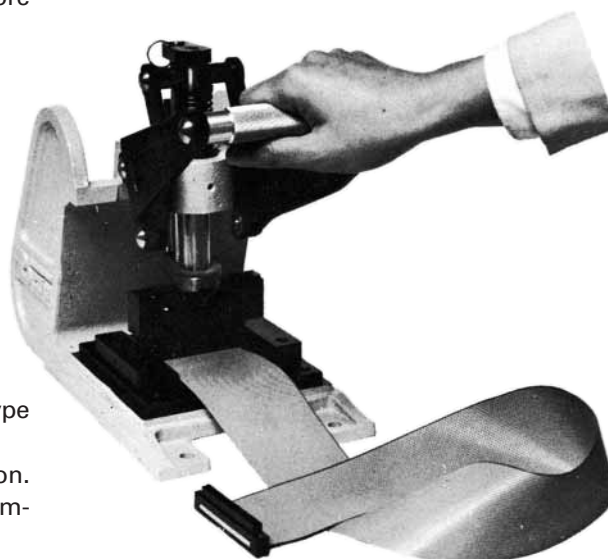





Компания «ЭлектроПласт» предлагает заключение долгосрочных отношений при поставках импортных электронных компонентов на взаимовыгодных условиях!

Наши преимущества:

- Оперативные поставки широкого спектра электронных компонентов отечественного и импортного производства напрямую от производителей и с крупнейших мировых складов;
- Поставка более 17-ти миллионов наименований электронных компонентов;
- Поставка сложных, дефицитных, либо снятых с производства позиций;
- Оперативные сроки поставки под заказ (от 5 рабочих дней);
- Экспресс доставка в любую точку России;
- Техническая поддержка проекта, помощь в подборе аналогов, поставка прототипов;
- Система менеджмента качества сертифицирована по Международному стандарту ISO 9001;
- Лицензия ФСБ на осуществление работ с использованием сведений, составляющих государственную тайну;
- Поставка специализированных компонентов (Xilinx, Altera, Analog Devices, Intersil, Interpoint, Microsemi, Aeroflex, Peregrine, Syfer, Eurofarad, Texas Instrument, Miteq, Cobham, E2V, MA-COM, Hittite, Mini-Circuits, General Dynamics и др.);

Помимо этого, одним из направлений компании «ЭлектроПласт» является направление «Источники питания». Мы предлагаем Вам помощь Конструкторского отдела:

- Подбор оптимального решения, техническое обоснование при выборе компонента;
- Подбор аналогов;
- Консультации по применению компонента;
- Поставка образцов и прототипов;
- Техническая поддержка проекта;
- Защита от снятия компонента с производства.



#### Как с нами связаться

**Телефон:** 8 (812) 309 58 32 (многоканальный)

**Факс:** 8 (812) 320-02-42

**Электронная почта:** [org@eplast1.ru](mailto:org@eplast1.ru)

**Адрес:** 198099, г. Санкт-Петербург, ул. Калинина, дом 2, корпус 4, литера А.