



SANYO Semiconductors

DATA SHEET

An ON Semiconductor Company

LA6583MC

Monolithic Linear IC
Fan Motor Driver
BTL Driver Single-Phase Full-Wave

Overview

The LA6583MC is a low-saturation BTL output linear driving motor driver for single-phase bipolar fan motors. It features quite, low power, high efficiency drive that suppresses reactive current. It is optimal for use in applications that require miniaturization and low noise, such as CPU cooling fan motors and 5 to 12V electronic game products.

Features

- Single-phase full-wave linear drive with BTL output (gain resistance 1K-360K)
 : Most appropriate for consumer appliances power supply and car audio system, namely equipment that requires silence because this has no switching noise.
- Low-voltage operation possible, with wide operable voltage range (2.8 to 13.8V)
- Low saturation output (Upper + lower saturation voltage: $V_{O\ sat}$ (total) = 1.1Vtyp, $I_O = 200\text{mA}$)
 : High coil efficiency with low current drain. IC itself does not generate much heat.
- Lock protection and auto return circuits built-in
- Lock protection signal output (L during rotation, H at stop; open collector output)
- FG output (rotation speed detection output: open collector output)
- Hall bias built-in (VHB = 1.3V)
- Heat protection circuit (Design guarantee)
 : When the large current flows because of output short-circuit, raising the IC chip temperature above 180°C, the heat protection circuit suppresses the drive current, preventing IC burn and breakdown.
- Compact and high heat capacity package

■ Any and all SANYO Semiconductor Co.,Ltd. products described or contained herein are, with regard to "standard application", intended for the use as general electronics equipment. The products mentioned herein shall not be intended for use for any "special application" (medical equipment whose purpose is to sustain life, aerospace instrument, nuclear control device, burning appliances, transportation machine, traffic signal system, safety equipment etc.) that shall require extremely high level of reliability and can directly threaten human lives in case of failure or malfunction of the product or may cause harm to human bodies, nor shall they grant any guarantee thereof. If you should intend to use our products for new introduction or other application different from current conditions on the usage of automotive device, communication device, office equipment, industrial equipment etc., please consult with us about usage condition (temperature, operation time etc.) prior to the intended use. If there is no consultation or inquiry before the intended use, our customer shall be solely responsible for the use.

■ Specifications of any and all SANYO Semiconductor Co.,Ltd. products described or contained herein stipulate the performance, characteristics, and functions of the described products in the independent state, and are not guarantees of the performance, characteristics, and functions of the described products as mounted in the customer's products or equipment. To verify symptoms and states that cannot be evaluated in an independent device, the customer should always evaluate and test devices mounted in the customer's products or equipment.

LA6583MC

Specifications

Maximum Ratings at Ta = 25°C

Parameter	Symbol	Conditions	Ratings	Unit
Supply voltage	V _{CC} max		15	V
Output current	I _O max		0.8	A
Output withstand voltage	V _O max		15	V
RD/FG output withstand	VRD/FG max		15	V
RD/FG output current	IRD/FG max		5	mA
HB output current	I _B max		10	mA
Allowable dissipation	P _d max	Mounted on a specified board *1	800	mW
Operating temperature	T _{opr}	*2	-30 to +100	°C
Storage temperature	T _{stg}		-55 to +150	°C

*1: Mounted on a specified board: 114.3mm × 76.1mm × 1.6mm glass epoxy

*2: T_j = 150°C Use this IC within a range where the chip temperature does not exceed T_j = 150 °C during operation.

Caution 1) Absolute maximum ratings represent the value which cannot be exceeded for any length of time.

Caution 2) Even when the device is used within the range of absolute maximum ratings, as a result of continuous usage under high temperature, high current, high voltage, or drastic temperature change, the reliability of the IC may be degraded. Please contact us for the further details.

Recommended Operating Conditions at Ta = 25°C

Parameter	Symbol	Conditions	Ratings	Unit
Supply voltage	V _{CC}		2.8 to 14.0	V
Common-phase input voltage range of Hall input	V _{ICM}		0 to V _{CC} -1.5	V

Electrical Characteristics at Ta = 25°C, V_{CC} = 12.0V, unless especially specified.

Parameter	Symbol	Conditions	Ratings			Unit
			min	typ	max	
Circuit Current	I _{CC1}	During drive (CT=L)	4	6	9	mA
	I _{CC2}	At lock protection (CT=H)	2	4	6	mA
Lock detection capacitor charge current	I _{CT1}		2.0	2.8	3.5	μA
Capacitor discharge current	I _{CT2}		0.15	0.23	0.30	μA
Capacitor charge/discharge current ratio	R _{CT}	R _{CT} =I _{CT1} /I _{CT2}	9	12	15	-
CT charge voltage	V _{CT1}		1.6	1.7	1.8	V
CT discharge voltage	V _{CT2}		0.6	0.7	0.8	V
OUT output L saturation voltage	V _{OL}	I _O =200mA		0.2	0.3	V
OUT output H saturation voltage	V _{OH}	I _O =200mA		0.9	1.2	V
Hall input sensitivity	V _{HN}	Zero peak value (Including offset and hysteresis)		7	15	mV
RD/FG output pin L voltage	VRD/FG	IRD/FG=5mA		0.1	0.2	V
RD/FG output pin leak current	IRD/FGL	VRD/FG=15V		1	30	μA
HB output voltage	V _{HB}	I _{HB} =5mA	1.3	1.5	1.7	V
Thermal protection circuit	T _{SD}	Design target value *3	150	180	210	°C

*3: This is a design guarantee value and no measurement with an independent unit is made.

Thermal protection circuit is built in this IC for the prevention of burnout of IC and thermal destruction.

But, since the operation is outside the guarantee temperature range, thermal design must be made so that the thermal protection circuit is not activated during normal fan operation.

Sample Application Circuit

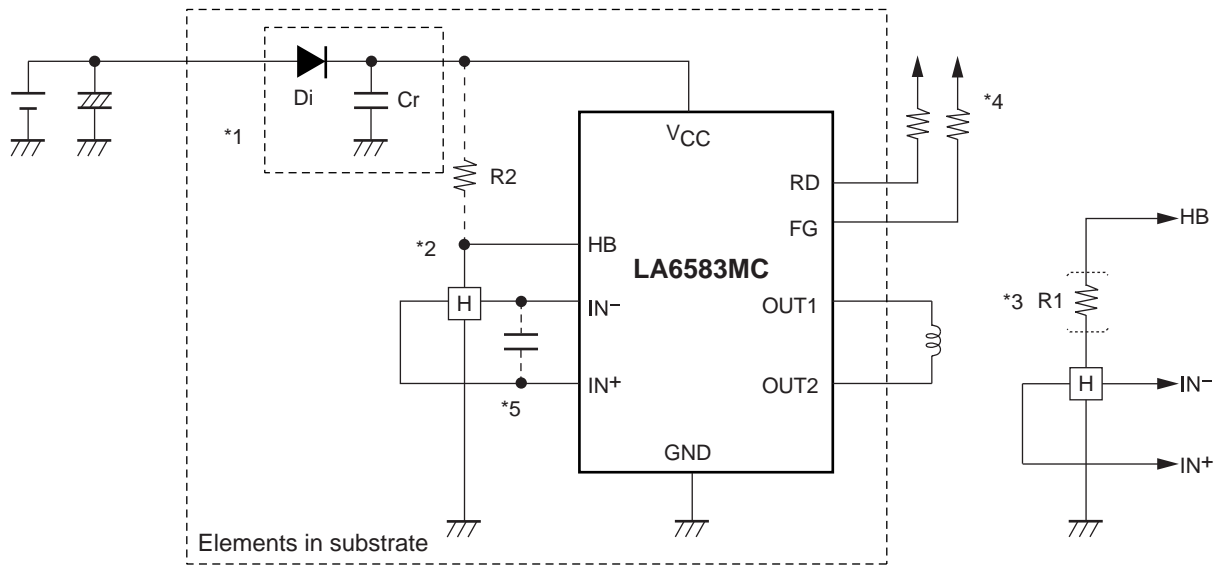

- *1: When Di to prevent breakdown in case of reverse connection is used, it is necessary to insert a capacitor Cr to secure the regenerative current route. Similarly, Cr is necessary to enhance the reliability when there is no capacitor near the fan power line.
- *2: When the Hall bias is taken from the HB pin, constant-voltage bias is made with about 1.3V. Therefore, the Hall output becomes the stable amplitude voltage satisfactory in temperature characteristics. By inserting R2 to obtain the Hall bias from both VCC and HB, as shown in the figure, heat generation of IC can be suppressed.
- *3: In this IC, the Hall output amplitude is amplified to produce the drive waveform. Therefore, the switching time of the current application direction is determined by the Hall output, causing change in the characteristics of motor. If the Hall element output amplitude is large, the start-up performance and efficiency of the IC are improved. On the other hand, if the Hall element output amplitude is small, low-noise drive is ensured. Adjust the Hall element output amplitude by R1.
- *4: Keep this open when this is not used.
- *5: When the wiring from the Hall output to IC Hall input is long, noise may be carried through the wiring. In this case, insert the capacitor as shown in the figure.

Internal Equivalent Circuit Diagram

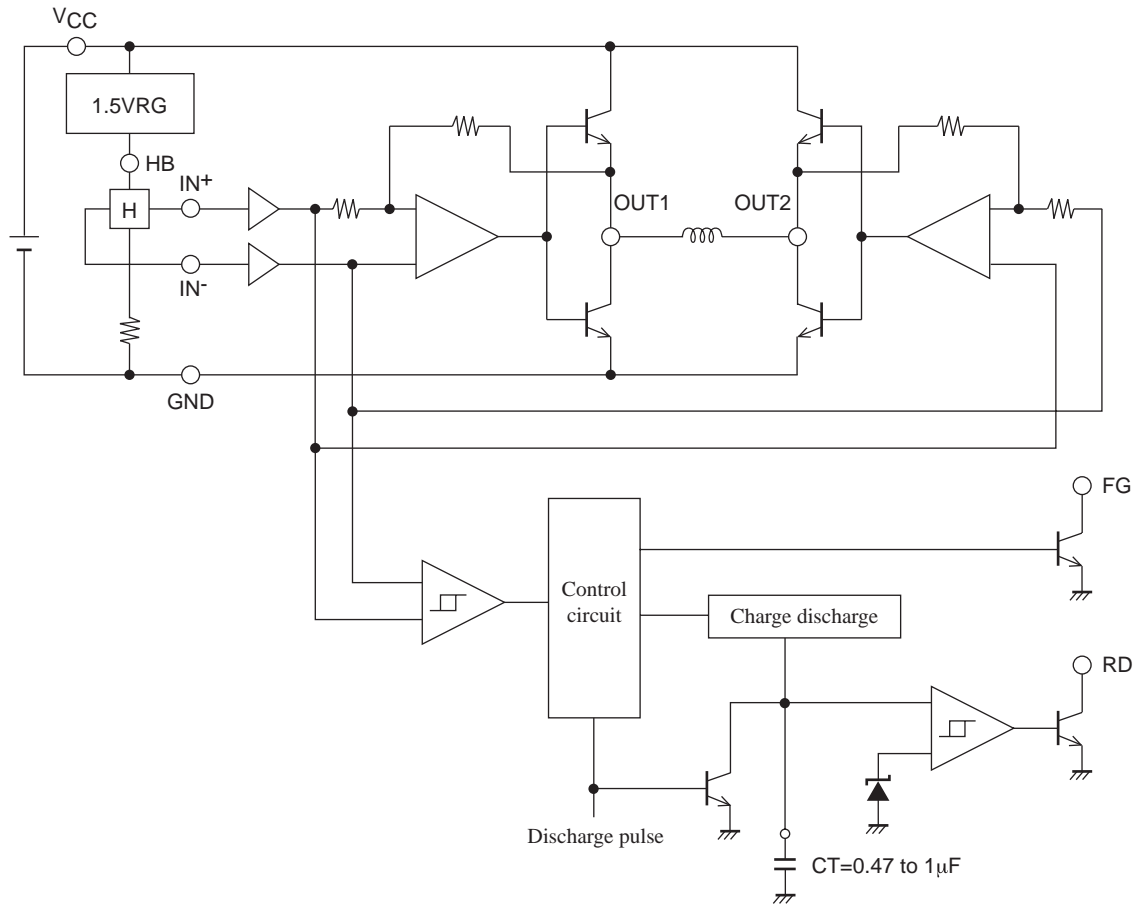

■ SANYO Semiconductor Co.,Ltd. assumes no responsibility for equipment failures that result from using products at values that exceed, even momentarily, rated values (such as maximum ratings, operating condition ranges, or other parameters) listed in products specifications of any and all SANYO Semiconductor Co.,Ltd. products described or contained herein.

■ SANYO Semiconductor Co.,Ltd. strives to supply high-quality high-reliability products, however, any and all semiconductor products fail or malfunction with some probability. It is possible that these probabilistic failures or malfunction could give rise to accidents or events that could endanger human lives, trouble that could give rise to smoke or fire, or accidents that could cause damage to other property. When designing equipment, adopt safety measures so that these kinds of accidents or events cannot occur. Such measures include but are not limited to protective circuits and error prevention circuits for safe design, redundant design, and structural design.

■ In the event that any or all SANYO Semiconductor Co.,Ltd. products described or contained herein are controlled under any of applicable local export control laws and regulations, such products may require the export license from the authorities concerned in accordance with the above law.

■ No part of this publication may be reproduced or transmitted in any form or by any means, electronic or mechanical, including photocopying and recording, or any information storage or retrieval system, or otherwise, without the prior written consent of SANYO Semiconductor Co.,Ltd.

■ Any and all information described or contained herein are subject to change without notice due to product/technology improvement, etc. When designing equipment, refer to the "Delivery Specification" for the SANYO Semiconductor Co.,Ltd. product that you intend to use.

■ Upon using the technical information or products described herein, neither warranty nor license shall be granted with regard to intellectual property rights or any other rights of SANYO Semiconductor Co.,Ltd. or any third party. SANYO Semiconductor Co.,Ltd. shall not be liable for any claim or suits with regard to a third party's intellectual property rights which has resulted from the use of the technical information and products mentioned above.

This catalog provides information as of March, 2012. Specifications and information herein are subject to change without notice.



Компания «ЭлектроПласт» предлагает заключение долгосрочных отношений при поставках импортных электронных компонентов на взаимовыгодных условиях!

Наши преимущества:

- Оперативные поставки широкого спектра электронных компонентов отечественного и импортного производства напрямую от производителей и с крупнейших мировых складов;
- Поставка более 17-ти миллионов наименований электронных компонентов;
- Поставка сложных, дефицитных, либо снятых с производства позиций;
- Оперативные сроки поставки под заказ (от 5 рабочих дней);
- Экспресс доставка в любую точку России;
- Техническая поддержка проекта, помощь в подборе аналогов, поставка прототипов;
- Система менеджмента качества сертифицирована по Международному стандарту ISO 9001;
- Лицензия ФСБ на осуществление работ с использованием сведений, составляющих государственную тайну;
- Поставка специализированных компонентов (Xilinx, Altera, Analog Devices, Intersil, Interpoint, Microsemi, Aeroflex, Peregrine, Syfer, Eurofarad, Texas Instrument, Miteq, Cobham, E2V, MA-COM, Hittite, Mini-Circuits, General Dynamics и др.);

Помимо этого, одним из направлений компании «ЭлектроПласт» является направление «Источники питания». Мы предлагаем Вам помощь Конструкторского отдела:

- Подбор оптимального решения, техническое обоснование при выборе компонента;
- Подбор аналогов;
- Консультации по применению компонента;
- Поставка образцов и прототипов;
- Техническая поддержка проекта;
- Защита от снятия компонента с производства.



Как с нами связаться

Телефон: 8 (812) 309 58 32 (многоканальный)

Факс: 8 (812) 320-02-42

Электронная почта: org@eplast1.ru

Адрес: 198099, г. Санкт-Петербург, ул. Калинина, дом 2, корпус 4, литера А.