

SFH250 and SFH250V

Receiver with analog output for polymer optical fiber applications



Data Sheet



Lead (Pb) Free
RoHS 6 fully
compliant

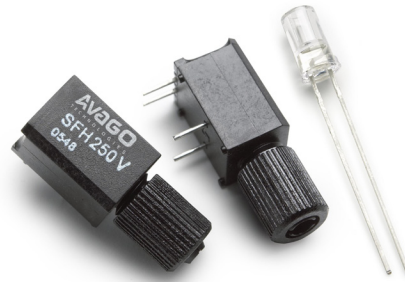

Description

The SFH250 is a low-cost 650nm receiver for optical data transmission with polymer optical fiber. This Si-pin-photodiode works fine with the AVAGO transmitter SFH757. According to the intensity of the incident light the SFH250 generates an analog photocurrent. In typical applications the SFH250 is operated in reverse-biasing and is installed in series with a resistor, where the voltage tapping is taken. By increasing the reverse voltage the switching times decrease and the SFH250 can be used for transmission speeds up to 100MBd.

Components of the SFH series are optimized for easy coupling. No fiber stripping is required, only the cut fiber has to be inserted into the selected SFH component.

SFH250

The transparent plastic package has an aperture where a 2.2mm fiber end can be inserted. This very easy coupling method is extremely cost-effective.

SFH250V

The V-housing allows easy coupling of unconnectorized 2.2mm polymer optical fiber by means of an axial locking screw.

Ordering Information



SFH250

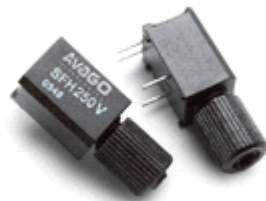

SFH250V

Type	Ordering Code
SFH250	SP000063866
SFH250V	SP000063852

Features

- Fast Switching Time
- Sensitive in visible and near IR Range
- High linearity
- 2.2mm aperture holds standard 980/1000/2200 um plastic fiber
- No fiber stripping required
- Molded microlens for efficient coupling

Plastic Direct Fiber Connector housing (V-housing)

- Locking screw attached to the connector
- Interference-free transmission by the light-tight housing
- Transmitter and receiver can be positioned flexibly
- No cross talk
- Auto insertable and wave solderable
- Supplied in tubes

Applications

- Household electronics
- Power electronics
- Optical networks
- Light barriers

Application Literature

AN #	Description
5342	General information about the SFH series with Selection Guide and recommendations regarding System Planning and Mounting
5341	Information about Basic and Special Circuits for Transmitter and Receiver of the SFH series

Package Dimensions SFH250

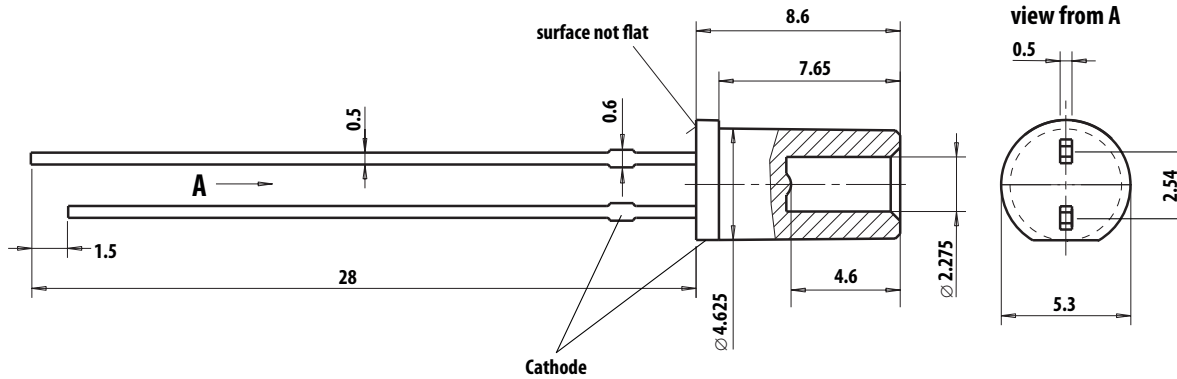

Dimensions in mm

SFH250V

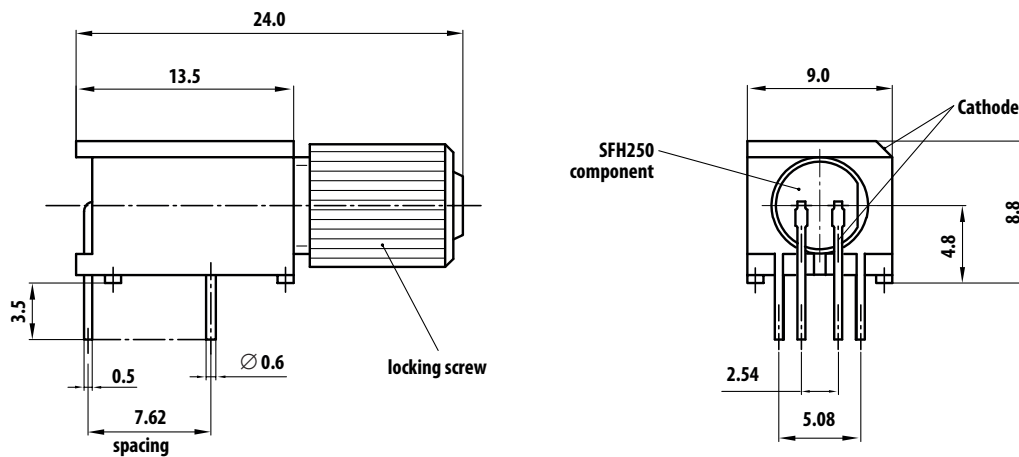

Dimensions in mm

Package V-housing Color

SFH V-series components are color coded just like other Avago fiber optic components. The SFH757V transmitter has a white colored housing; the SFH250V and SFH551/1-1V receiver components have a black colored housing. This prevents mistakes while making connections. Product designation and date of manufacture are printed on the housing.

Package V-housing mounting pins

SFH V-series components have two pins that are electrically isolated from the inner circuit. The pins are only designed for mounting the V-housing to the PCB surface. This helps increase stability, which is needed during fixing the fiber end by the axial locking screw.

The retention force between the soldered mounting pins and the V-housing of the SFH component is about 20 N (with a vertical exertion of force). This is an approximate value.

Package V-housing axial locking screw

Components of the SFH V-series are equipped with an axial locking screw for easy coupling to the unconnectorized 2.2 mm polymer optical fiber. The force that is necessary to pull a jammed fiber out of the V-housing is typically 50 N (with a torque of 15 cNm for tightening the locking screw). This is an approximate value that is very dependent on the fiber and torque combination.

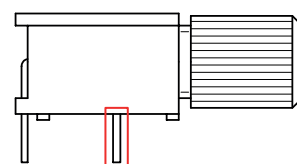

Package V-housing mounting pins

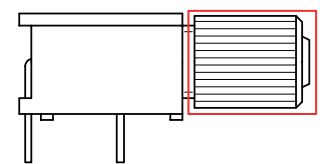

Package V-housing axial locking screw

Technical Data

Absolute Maximum Ratings

Parameter	Symbol	Min	Typ	Max	Unit	Notes	Figure
Operating Temperature range	T_C	-40		+85	°C		
Storage Temperature range	T_{stg}	-40		+100	°C		
Junction Temperature	T_J			100	°C		
Soldering Temperature (2mm from case bottom, $t \leq 5s$)	T_S			+260	°C		
Reverse Voltage	V_R			30	V		
Power Dissipation	P_{tot}			100	mW		
Thermal Resistance (Junction/Air)	R_{thJA}			750	K/W		
Electrostatic Discharge Voltage Capability	ESD			2000	V	1	
Electrostatic Discharge Voltage Capability	ESD			400	V	2	

Notes:

- ESD Capability for all Pins HBM(Human Body Model) according JESD22-A114
- ESD Capability for all Pins MM (Machine Model) according JESD22-A115

Characteristics ($T_A = -40^\circ\text{C}$ to $+85^\circ\text{C}$) unless otherwise specified

Parameter	Symbol	Min	Typ*	Max	Unit	Notes	Figure
Maximum Photosensitivity Wavelength	λ_{smax}		850		nm		1
Photosensitivity Spectral Range ($S=80\%S_{max}$)	λ_s	400		1100	nm		1
Dark Current ($R_L=50\Omega, V_R=5V, T_A=25^\circ\text{C}$)	I_R		1	10	nA	2	5
Capacitance ($f=1\text{MHz}, V_R=0$)	C_S		11		pF		5
Switching Times ($R_L=50\Omega, V_R=5.0V, \lambda=650\text{nm}$)							
T_{rise} (10%...90%)	t_r		5	12	ns	1,2	6, 4
T_{fall} (90%.. 10%)	t_f		8	16	ns		
Switching Times ($R_L=50\Omega, V_R=30.0V, \lambda=650\text{nm}$)							
T_{rise} (10%...90%)	t_r		3	10	ns	1,2	6, 4
T_{fall} (90%.. 10%)	t_f		4	10	ns		
Photocurrent ($R_L=50\Omega, P_{opt}=10\mu\text{W}, V_R=5.0V, \lambda=650\text{nm}$)	I_P	2.4	4.4		μA		2,3
Responsivity ($\lambda=650\text{nm}, R_L=50\Omega$)	R_{IP}	240	440		$\mu\text{A} / \text{mW}$	3	3
Photocurrent Temperature Coefficient ($\lambda=650\text{nm}$)	T_{IP}		-0.03		% / K		2

* Typical value = mean value at $T_A=25^\circ\text{C}$

Note:

- Measured with optical input power -4dBm(mean) and pattern: "1010" at 5MBd
- Increase with temperature
- Not strictly linear behavior. Actual value at high optical input power could vary from the typical value.

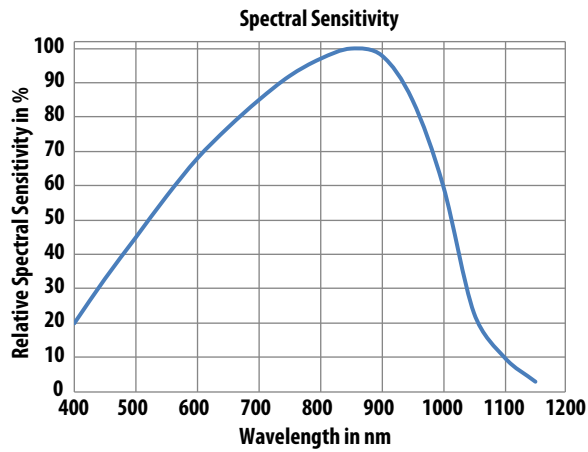

Figure 1. Typical Spectral Sensitivity

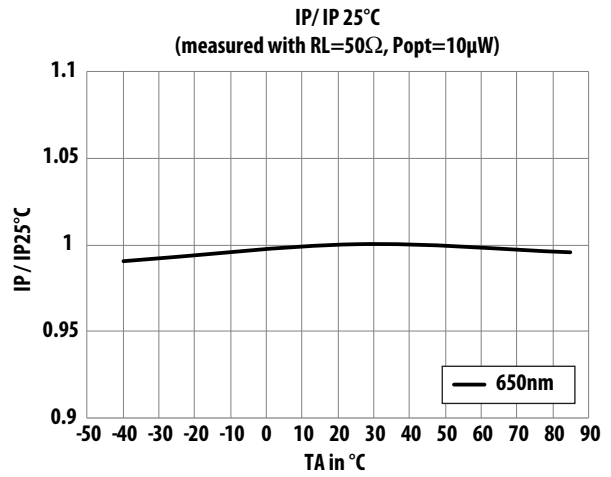

Figure 2. Typical Photocurrent depending on temperature

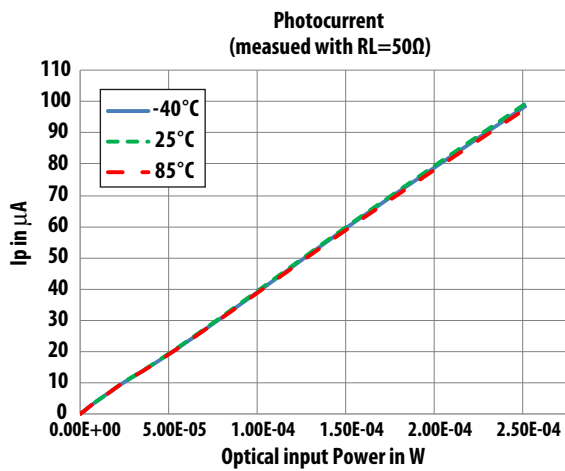

Figure 3. Typical Photocurrent at constant "Light ON"

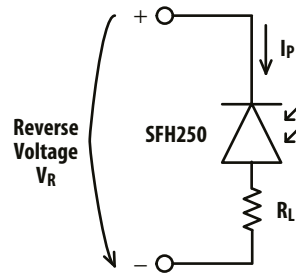

Figure 4. Test circuit

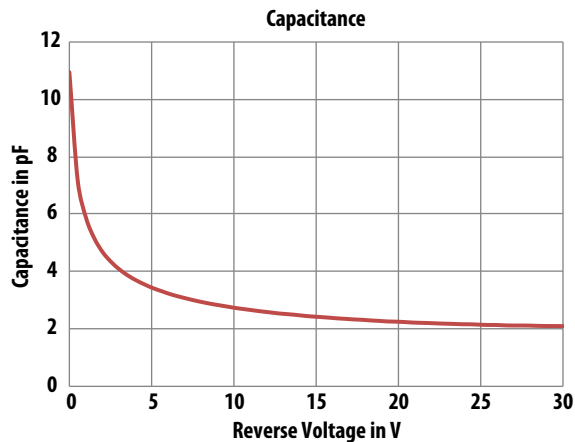

Figure 5. Typical Capacitance; measured at TA=25°C with fmeasured =1MHz

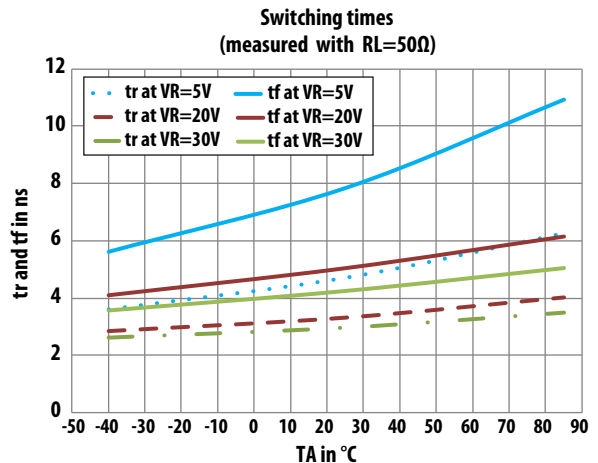

Figure 6. Typical Switching times; measured with pattern "1010" (5Mbd) at -4dBm (mean) optical input power

For product information and a complete list of distributors, please go to our web site: www.avagotech.com

Avago, Avago Technologies, and the A logo are trademarks of Avago Technologies in the United States and other countries. Data subject to change. Copyright © 2005-2011 Avago Technologies. All rights reserved. Obsoletes AV01-0711EN AV02-3095EN - October 25, 2011





Компания «ЭлектроПласт» предлагает заключение долгосрочных отношений при поставках импортных электронных компонентов на взаимовыгодных условиях!

Наши преимущества:

- Оперативные поставки широкого спектра электронных компонентов отечественного и импортного производства напрямую от производителей и с крупнейших мировых складов;
- Поставка более 17-ти миллионов наименований электронных компонентов;
- Поставка сложных, дефицитных, либо снятых с производства позиций;
- Оперативные сроки поставки под заказ (от 5 рабочих дней);
- Экспресс доставка в любую точку России;
- Техническая поддержка проекта, помощь в подборе аналогов, поставка прототипов;
- Система менеджмента качества сертифицирована по Международному стандарту ISO 9001;
- Лицензия ФСБ на осуществление работ с использованием сведений, составляющих государственную тайну;
- Поставка специализированных компонентов (Xilinx, Altera, Analog Devices, Intersil, Interpoint, Microsemi, Aeroflex, Peregrine, Syfer, Eurofarad, Texas Instrument, Miteq, Cobham, E2V, MA-COM, Hittite, Mini-Circuits, General Dynamics и др.);

Помимо этого, одним из направлений компании «ЭлектроПласт» является направление «Источники питания». Мы предлагаем Вам помощь Конструкторского отдела:

- Подбор оптимального решения, техническое обоснование при выборе компонента;
- Подбор аналогов;
- Консультации по применению компонента;
- Поставка образцов и прототипов;
- Техническая поддержка проекта;
- Защита от снятия компонента с производства.



Как с нами связаться

Телефон: 8 (812) 309 58 32 (многоканальный)

Факс: 8 (812) 320-02-42

Электронная почта: org@eplast1.ru

Адрес: 198099, г. Санкт-Петербург, ул. Калинина, дом 2, корпус 4, литера А.