

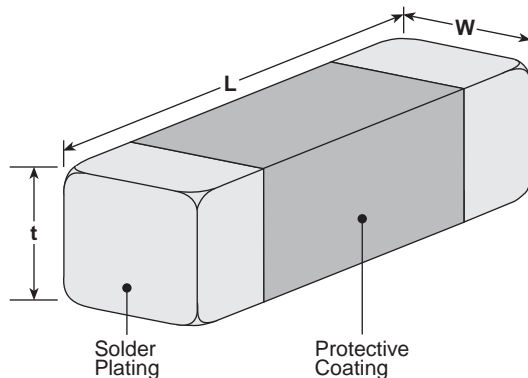

### features

- Low dielectric loss at high frequency (high Q)
- Narrow tolerance of capacitance
- Excellent temperature characteristics
- High reliability and no polarity by single layer ceramic substrate construction
- 0.10 - 1.3 pF available by 0.05 pF range (HFC1005 series)
- 0.10 - 1.20 pF available by 0.05 pF range (HFC1410, 1608, 1610, 1612 series)
- Marking: Brown body color with no marking
- Products with lead-free terminations meet EU RoHS requirements

### dimensions and construction



Size	Dimensions inches (mm)		
	L	W	t
<b>1005</b>	.039±.006 (1.0±0.15)	.02±.004 (0.5±0.1)	.02±.004 (0.5±0.1)
<b>1410</b>	.055±.006 (1.4±0.15)	.039±.004 (1.0±0.1)	.039±.004 (1.0±0.1)
<b>1608</b>	.063±.006 (1.6±0.15)	.031±.004 (0.8±0.1)	.028±.008 (0.7±0.2)
<b>1610</b>	.063±.006 (1.6±0.15)	.039±.004 (1.0±0.1)	.033±.01 (0.85±0.25)
<b>1612</b>	.063±.006 (1.6±0.15)	.047±.004 (1.2±0.1)	.043±.008 (1.1±0.2)

capacitors

### ordering information

New Part #	<b>HFC</b>	<b>1608</b>	<b>C</b>	<b>T</b>	<b>TD</b>	<b>R10</b>
	Type	Size	Material Code	Termination Material	Packaging	Nominal Capacitance
		1005: 1.0 x 0.5 mm 1410: 1.4 x 1.0 mm 1608: 1.6 x 0.8 mm 1610: 1.6 x 1.0 mm 1612: 1.6 x 1.2 mm	B C G H K N S T V W	T: Sn	TD: Paper tape (1005 only - 10,000 pieces/reel) TE: Embossed taping (1410, 1610, 1612 - 3,000 pieces/reel) (1608 - 4,000 pieces/reel)	2 significant digits + zeros "R" indicates decimal point

For further information on packaging, please refer to Appendix A.

## characteristics of dielectric materials

### HFC1005 Series

Material Code	$\epsilon_r$	$\tau_r$ (ppm/°C)
T	37.0±1.5	0±10
N	70.0±3.0	6±10
K	92.0±2.0	6±10
V	113.0±5.0	30±10
H	140.0±3.0	0±30
G	160.0±4.0	0±30
S	180.0±4.0	0±30

### HFC1005 Series (continued)

Material Code	$\epsilon_r$	$\tau_r$ (ppm/°C)
B	200.0±5.0	0±30
W	260.0±5.0	0±60

### HFC1410, 1608, 1610, 1612 Series

Material Code	$\epsilon_r$	$\tau_r$ (ppm/°C)
C	21.5±2.0	0±10
T	37.0±1.5	0±10
N	70.0±3.0	6±10
V	113.0±5.0	30±10

## applications and ratings

Part Designation	Capacitance (pF)	Tolerance Code (pF)	Material Code	Rated Voltage DC (V)	Operating Temperature Range
HFC1005TTTDR10	0.10	±0.015	T	50	-55°C to +125°C
HFC1005TTTDR15	0.15				
HFC1005NTTDR20	0.20	±0.030	N		
HFC1005NTTDR25	0.25				
HFC1005KTTDR30	0.30		K		
HFC1005KTTDR35	0.35				
HFC1005VTTDR40	0.40		V		
HFC1005VTTDR45	0.45				
HFC1005VTTDR50	0.50				
HFC1005VTTDR55	0.55				
HFC1005VTTDR60	0.60	±0.050	H		
HFC1005HTTDR65	0.65				
HFC1005HTTDR70	0.70		G		
HFC1005HTTDR75	0.75				
HFC1005GTTDR80	0.80		S		
HFC1005GTTDR85	0.85				
HFC1005GTTDR90	0.90		B		
HFC1005GTTDR95	0.95				
HFC1005STTD1R0	1.00				
HFC1005BTTD1R1	1.10	W			
HFC1005WTTD1R2	1.20				
HFC1005WTTD1R3	1.30				

Specifications given herein may be changed at any time without prior notice. Please confirm technical specifications before you order and/or use.

3/10/07

applications and ratings (continued)

Part Designation	Capacitance (pF)	Tolerance Code (pF)	Material Code	Rated Voltage DC (V)	Operating Temperature Range				
HFC1410VTTE1R1	1.10	±0.075	V	50	-55°C to +125°C				
HFC1410VTTE1R2	1.20								
HFC1410VTTE1R3	1.30								
HFC1608CTTER10	0.10	±0.015	C	50	-55°C to +125°C				
HFC1608TTTER15	0.15		T						
HFC1608NTTER20	0.20	±0.030	N	50	-55°C to +125°C				
HFC1608NTTER25	0.25								
HFC1608NTTER30	0.30								
HFC1608NTTER35	0.35								
HFC1608VTTER40	0.40		V						
HFC1608VTTER45	0.45								
HFC1608VTTER50	0.50								
HFC1608VTTER55	0.55								
HFC1610VTTER60	0.60					±0.030	V	50	-55°C to +125°C
HFC1610VTTER65	0.65								
HFC1610VTTER70	0.70								
HFC1610VTTER75	0.75	±0.050	V	50	-55°C to +125°C				
HFC1610VTTER80	0.80								
HFC1610VTTER85	0.85								
HFC1610VTTER90	0.90								
HFC1612VTTER95	0.95	±0.050	V	50	-55°C to +125°C				
HFC1612VTTE1R0	1.00								

capacitors

environmental applications

HFC1410, 1608, 1610, 1612 Series Type: HFC1612VT1R0R05M50 (1.0 PF)

Self Resonant Frequency (SRF) vs. Capacitance Value



Q vs. Frequency



ESR vs. Frequency



**environmental applications** (continued)

**Electrical Characteristics**

Parameter	Requirement	Test Method
Capacitance	Within the specified tolerance of parts	Frequency: 1 MHz Voltage: 1 Vrms Instrument: YHP4278A
Q Value	100 or more	Frequency: 1 MHz Voltage: 1 Vrms Instrument: YHP4278A
Insulation Resistance	10,000 MΩ or more	Test Voltage: Rated voltage Electrification Time: 60 seconds ± 5 seconds
Breakdown Voltage	No breakdown	Test Voltage: 300% of the rated voltage Electrification Time: 1 second to 5 seconds Limit Surge Current: 50 mA or less

**Mechanical Characteristics**

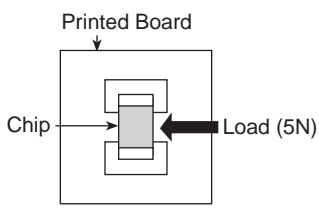
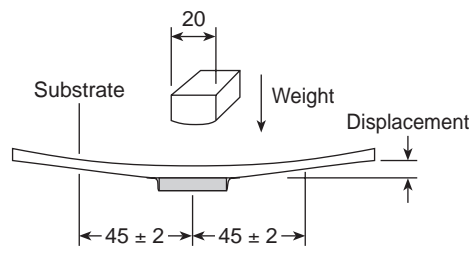
Parameter	Requirement	Test Method
Adhesion of Electrodes	No mechanical damage	A static load of 5N (0.5 kgf) shall be applied in the direction of the arrow as follows 
Core Body Strength	No mechanical damage	A static load of 5N (0.5 kgf) using a R 0.5 pressure rod shall be applied on the core of the component and held for 10 seconds
Substrate Bending Test	Visual Examination: No mechanical damage Capacitance: Within ±2.0% or ±0.02 pF whichever is more Q value: 100 or more Insulation Resistance: 10,000 MΩ or more	Solder a specimen to the substrate and bend it (Displacement: 2mm) 

**environmental applications** (continued)

**Endurance Characteristics**

Parameter	Requirement	Test Method
Solderability	A new coating of solder shall cover a minimum of 95% of the surface being immersed	Flux: 25 wt% colophony Solder: H60A (silver 3%) Preheating: 150°C for 1 minute Soldering Temperature: 230°C ± 5°C Soldering Temperature: 215°C ± 5°C (HFC1005) Immersion Time: 3 seconds ± 1 second
Resistance to Solder Heat	Visual Examination: No mechanical damage Capacitance: Within ±2.0% or ±0.02 pF whichever is more Q value: 100 or more Insulation Resistance: 10,000 MΩ or more	Flux: 25 wt% colophony Solder: H60A (silver 3%) Soldering Temperature: 270°C ± 5°C Immersion Time: 10 seconds ± 1 second
Resistance to Humidity (Load Test)		Temperature: 60°C ± 2°C Relative Humidity: 95% RH Test Voltage: Rated voltage Test Hours: 1000 -0/+48 hours
Resistance to Humidity (Unload Test)		Temperature: 85°C ± 2°C Relative Humidity: 85% RH Test Hours: 1000 -0/+48 hours
Resistance to High Temperature		Temperature: 125°C ± 2°C Test Voltage: Rated voltage Test Hours: 1000 -0/+48 hours
Resistance to Low Heat		Temperature: -55°C ± 2°C Test Hours: 1000 -0/+48 hours
Temperature Cycle		Temperature: -55°C for 30 min., 125°C for 30 min. Hours for 1 Cycle: 2 hours Temperature Cycle: 50 cycles or more
Vibration		Frequency of Vibration: 10 to 100 Hz Sweeping: 10→100→10 Hz, 5 minutes, 5.0 G This motion shall be applied for a period of 2 hours in each of 3 mutually perpendicular axis
Shock		Half of sine wave (100 G) shall be applied for a period of 5 msec. in each of 3 mutually perpendicular axis

capacitors

The specimen shall be subjected to standard atmospheric condition for 24 hours after which measurement shall be made.



Компания «ЭлектроПласт» предлагает заключение долгосрочных отношений при поставках импортных электронных компонентов на взаимовыгодных условиях!

Наши преимущества:

- Оперативные поставки широкого спектра электронных компонентов отечественного и импортного производства напрямую от производителей и с крупнейших мировых складов;
- Поставка более 17-ти миллионов наименований электронных компонентов;
- Поставка сложных, дефицитных, либо снятых с производства позиций;
- Оперативные сроки поставки под заказ (от 5 рабочих дней);
- Экспресс доставка в любую точку России;
- Техническая поддержка проекта, помощь в подборе аналогов, поставка прототипов;
- Система менеджмента качества сертифицирована по Международному стандарту ISO 9001;
- Лицензия ФСБ на осуществление работ с использованием сведений, составляющих государственную тайну;
- Поставка специализированных компонентов (Xilinx, Altera, Analog Devices, Intersil, Interpoint, Microsemi, Aeroflex, Peregrine, Syfer, Eurofarad, Texas Instrument, Miteq, Cobham, E2V, MA-COM, Hittite, Mini-Circuits, General Dynamics и др.);

Помимо этого, одним из направлений компании «ЭлектроПласт» является направление «Источники питания». Мы предлагаем Вам помощь Конструкторского отдела:

- Подбор оптимального решения, техническое обоснование при выборе компонента;
- Подбор аналогов;
- Консультации по применению компонента;
- Поставка образцов и прототипов;
- Техническая поддержка проекта;
- Защита от снятия компонента с производства.



#### Как с нами связаться

**Телефон:** 8 (812) 309 58 32 (многоканальный)

**Факс:** 8 (812) 320-02-42

**Электронная почта:** [org@eplast1.ru](mailto:org@eplast1.ru)

**Адрес:** 198099, г. Санкт-Петербург, ул. Калинина, дом 2, корпус 4, литера А.