

Twelve Output Differential Buffer for PCIe Gen3

9DB1233

Recommended Application

12 output PCIe Gen3 zero-delay/fanout buffer

General Description

The 9DB1233 zero-delay buffer supports PCIe Gen3 requirements, while being backwards compatible to PCIe Gen2 and Gen1. The 9DB1233 is driven by a differential SRC output pair from an IDT 932S421 or 932SQ420 or equivalent main clock generator. It attenuates jitter on the input clock and has a selectable PLL bandwidth to maximize performance in systems with or without Spread-Spectrum clocking.

Output Features

- 12 - 0.7V current mode differential HCSL output pairs

Features/Benefits

- 3 Selectable SMBus Addresses/Multiple devices can share the same SMBus Segment
- 12 OE# pins/Hardware control of each output
- PLL or bypass mode/PLL can dejitter incoming clock
- Selectable PLL bandwidth/minimizes jitter peaking in downstream PLL's
- Spread Spectrum Compatible/tracks spreading input clock for low EMI
- SMBus Interface/unused outputs can be disabled
- Supports undriven differential outputs in Power Down mode for power management

Key Specifications

- Output cycle-cycle jitter < 50ps.
- Output-to-output skew < 50 ps
- PCIe Gen3 phase jitter < 1.0ps RMS
- Pin compatible with DB1200 Yellow Cover Device

Functional Block Diagram

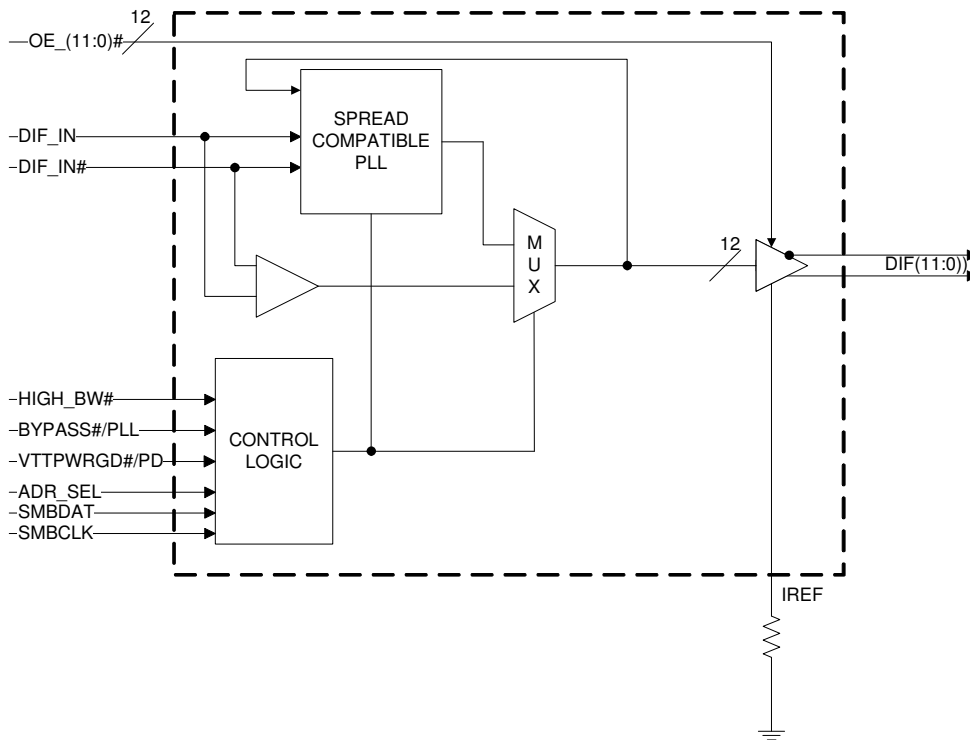

Pin Configuration

VDD	1	64	VDDA
DIF_IN	2	63	AGND
DIF_IN#	3	62	IREF
GND	4	61	VDD
OE0#	5	60	OE11#
DIF_0	6	59	DIF_11
DIF_0#	7	58	DIF_11#
VDD	8	57	VDD
GND	9	56	GND
OE1#	10	55	OE10#
DIF_1	11	54	DIF_10
DIF_1#	12	53	DIF_10#
OE2#	13	52	OE9#
DIF_2	14	51	DIF_9
DIF_2#	15	50	DIF_9#
GND	16	49	GND
VDD	17	48	VDD
OE3#	18	47	OE8#
DIF_3	19	46	DIF_8
DIF_3#	20	45	DIF_8#
OE4#	21	44	OE7#
DIF_4	22	43	DIF_7
DIF_4#	23	42	DIF_7#
VDD	24	41	VDD
GND	25	40	GND
OE5#	26	39	OE6#
DIF_5	27	38	DIF_6
DIF_5#	28	37	DIF_6#
**ADR_SEL	29	36	VTTTPWRGD#/PD
HIGH_BW#	30	35	BYPASS#/PLL
VDD	31	34	GND
SMBCLK	32	33	SMBDAT

9DB1233

64-TSSOP

** Indicates 120K ohm Pulldown

SMBus Address Selection (Pin 29)

ADR_SEL	Voltage	SMBus Adr (Wr/Rd)
Low	<0.8V	DC/DD
Mid	1.2<Vin<1.8V	D6/D7
High	Vin > 2.0V	D4/D5

Power Groups

Pin Number		Description
VDD	GND	
1	4	DIF_IN/DIF_IN#
8, 17, 24, 41, 48, 57	9, 16, 25, 40, 49, 56	DIF(11:0)
N/A	63	IREF
64	63	Analog VDD & GND for PLL core

Note: Please treat pin 1 as an analog VDD.

Pin Description

PIN #	PIN NAME	TYPE	DESCRIPTION
1	VDD	PWR	Power supply, nominal 3.3V
2	DIF_IN	IN	0.7 V Differential TRUE input
3	DIF_IN#	IN	0.7 V Differential Complementary Input
4	GND	PWR	Ground pin.
5	OE0#	IN	Active low input for enabling DIF pair 0. 1 =disable outputs, 0 = enable outputs
6	DIF_0	OUT	0.7V differential true clock output
7	DIF_0#	OUT	0.7V differential Complementary clock output
8	VDD	PWR	Power supply, nominal 3.3V
9	GND	PWR	Ground pin.
10	OE1#	IN	Active low input for enabling DIF pair 1. 1 =disable outputs, 0 = enable outputs
11	DIF_1	OUT	0.7V differential true clock output
12	DIF_1#	OUT	0.7V differential Complementary clock output
13	OE2#	IN	Active low input for enabling DIF pair 2. 1 =disable outputs, 0 = enable outputs
14	DIF_2	OUT	0.7V differential true clock output
15	DIF_2#	OUT	0.7V differential Complementary clock output
16	GND	PWR	Ground pin.
17	VDD	PWR	Power supply, nominal 3.3V
18	OE3#	IN	Active low input for enabling DIF pair 3. 1 =disable outputs, 0 = enable outputs
19	DIF_3	OUT	0.7V differential true clock output
20	DIF_3#	OUT	0.7V differential Complementary clock output
21	OE4#	IN	Active low input for enabling DIF pair 4. 1 =disable outputs, 0 = enable outputs
22	DIF_4	OUT	0.7V differential true clock output
23	DIF_4#	OUT	0.7V differential Complementary clock output
24	VDD	PWR	Power supply, nominal 3.3V
25	GND	PWR	Ground pin.
26	OE5#	IN	Active low input for enabling DIF pair 5. 1 =disable outputs, 0 = enable outputs
27	DIF_5	OUT	0.7V differential true clock output
28	DIF_5#	OUT	0.7V differential Complementary clock output
29	**ADR_SEL	IN	This tri-level input selects one of 3 SMBus addresses. See the SMBus Address Select Table for the addresses.
30	HIGH_BW#	IN	3.3V input for selecting PLL Band Width 0 = High, 1= Low
31	VDD	PWR	Power supply, nominal 3.3V
32	SMBCLK	IN	Clock pin of SMBUS circuitry, 5V tolerant

Pin Description (cont.)

PIN #	PIN NAME	TYPE	DESCRIPTION
33	SMBDAT	I/O	Data pin of SMBUS circuitry, 5V tolerant
34	GND	PWR	Ground pin.
35	BYPASS#/PLL	IN	Input to select Bypass(fan-out) or PLL (ZDB) mode 0 = Bypass mode, 1= PLL mode
36	VTTTPWRGD#/PD	IN	VTTTPWRGD# is an active low input used to sample latched inputs and allow the device to Power Up. PD is an asynchronous active high input pin used to put the device into a low power state. The internal clocks and PLLs are stopped.
37	DIF_6#	OUT	0.7V differential Complementary clock output
38	DIF_6	OUT	0.7V differential true clock output
39	OE6#	IN	Active low input for enabling DIF pair 6. 1 =disable outputs, 0 = enable outputs
40	GND	PWR	Ground pin.
41	VDD	PWR	Power supply, nominal 3.3V
42	DIF_7#	OUT	0.7V differential Complementary clock output
43	DIF_7	OUT	0.7V differential true clock output
44	OE7#	IN	Active low input for enabling DIF pair 7. 1 =disable outputs, 0 = enable outputs
45	DIF_8#	OUT	0.7V differential Complementary clock output
46	DIF_8	OUT	0.7V differential true clock output
47	OE8#	IN	Active low input for enabling DIF pair 8. 1 =disable outputs, 0 = enable outputs
48	VDD	PWR	Power supply, nominal 3.3V
49	GND	PWR	Ground pin.
50	DIF_9#	OUT	0.7V differential Complementary clock output
51	DIF_9	OUT	0.7V differential true clock output
52	OE9#	IN	Active low input for enabling DIF pair 9. 1 =disable outputs, 0 = enable outputs
53	DIF_10#	OUT	0.7V differential Complementary clock output
54	DIF_10	OUT	0.7V differential true clock output
55	OE10#	IN	Active low input for enabling DIF pair 10. 1 =disable outputs, 0 = enable outputs
56	GND	PWR	Ground pin.
57	VDD	PWR	Power supply, nominal 3.3V
58	DIF_11#	OUT	0.7V differential Complementary clock output
59	DIF_11	OUT	0.7V differential true clock output
60	OE11#	IN	Active low input for enabling DIF pair 11. 1 =disable outputs, 0 = enable outputs
61	VDD	PWR	Power supply, nominal 3.3V
62	IREF	OUT	This pin establishes the reference current for the differential current-mode output pairs. This pin requires a fixed precision resistor tied to ground in order to establish the appropriate current. 475 ohms is the standard value.
63	AGND	PWR	Analog Ground pin for Core PLL
64	VDDA	PWR	3.3V power for the PLL core.

Electrical Characteristics - Absolute Maximum Ratings

PARAMETER	SYMBOL	CONDITIONS	MIN	TYP	MAX	UNITS	NOTES
3.3V Core Supply Voltage	VDDA				4.6	V	1,2
3.3V Logic Supply Voltage	VDD				4.6	V	1,2
Input Low Voltage	V _{IL}		GND-0.5			V	1
Input High Voltage	V _{IH}	Except for SMBus interface			V _{DD} +0.5V	V	1
Input High Voltage	V _{IHSMB}	SMBus clock and data pins			5.5V	V	1
Storage Temperature	T _s		-65		150	°C	1
Junction Temperature	T _j				125	°C	1
Input ESD protection	ESD prot	Human Body Model	2000			V	1

¹Guaranteed by design and characterization, not 100% tested in production.

²Operation under these conditions is neither implied nor guaranteed.

Electrical Characteristics - Input/Supply/Common Parameters

TA = T_{COM}; Supply Voltage VDD = 3.3 V +/-5%

PARAMETER	SYMBOL	CONDITIONS	MIN	TYP	MAX	UNITS	NOTES
Ambient Operating Temperature	T _{COM}	Commercial range	0		70	°C	1
Input High Voltage	V _{IH}	Single-ended inputs, except SMBus, low threshold and tri-level inputs	2		V _{DD} + 0.3	V	1
Input Low Voltage	V _{IL}	Single-ended inputs, except SMBus, low threshold and tri-level inputs	GND - 0.3		0.8	V	1
Input Current	I _{IN}	Single-ended inputs, V _{IN} = GND, V _{IN} = VDD	-5		5	uA	1
	I _{INP}	Single-ended inputs V _{IN} = 0 V; Inputs with internal pull-up resistors V _{IN} = VDD; Inputs with internal pull-down resistors	-200		200	uA	1
Input Frequency	F _{ibyp}	V _{DD} = 3.3 V, Bypass mode	10		166	MHz	2
	F _{ipll}	V _{DD} = 3.3 V, 100MHz PLL mode	90	100.00	110	MHz	2
Pin Inductance	L _{pin}				7	nH	1
Capacitance	C _{IN}	Logic Inputs, except DIF_IN	1.5		5	pF	1
	C _{INDIF_IN}	DIF_IN differential clock inputs	1.5		5	pF	1,4
	C _{OUT}	Output pin capacitance			6	pF	1
Clk Stabilization	T _{STAB}	From V _{DD} Power-Up and after input clock stabilization or de-assertion of PD# to 1st clock			1.8	ms	1,2
Input SS Modulation Frequency	f _{MODIN}	Allowable Frequency (Triangular Modulation)	30		33	kHz	1
OE# Latency	t _{LATOE#}	DIF start after OE# assertion DIF stop after OE# deassertion	4		12	cycles	1,3
Tdrive_PD#	t _{DRVPD}	DIF output enable after PD# de-assertion			300	us	1,3
Tfall	t _F	Fall time of control inputs			5	ns	1,2
Trise	t _R	Rise time of control inputs			5	ns	1,2
SMBus Input Low Voltage	V _{ILSMB}				0.8	V	1
SMBus Input High Voltage	V _{IHSMB}		2.1		V _{DD} SMB	V	1
SMBus Output Low Voltage	V _{OLSMB}	@ I _{PULLUP}			0.4	V	1
SMBus Sink Current	I _{PULLUP}	@ V _{OL}	4			mA	1
Nominal Bus Voltage	V _{DD} SMB	3V to 5V +/- 10%	2.7		5.5	V	1
SCLK/SDATA Rise Time	t _{RSMB}	(Max VIL - 0.15) to (Min VIH + 0.15)			1000	ns	1
SCLK/SDATA Fall Time	t _{FSMB}	(Min VIH + 0.15) to (Max VIL - 0.15)			300	ns	1
SMBus Operating Frequency	f _{MAXSMB}	Maximum SMBus operating frequency			100	kHz	1,5

¹Guaranteed by design and characterization, not 100% tested in production.

²Control input must be monotonic from 20% to 80% of input swing.

³Time from deassertion until outputs are >200 mV

⁴DIF_IN input

⁵The differential input clock must be running for the SMBus to be active

Electrical Characteristics - Clock Input ParametersTA = T_{COM}; Supply Voltage VDD = 3.3 V +/-5%

PARAMETER	SYMBOL	CONDITIONS	MIN	TYP	MAX	UNITS	NOTES
Input High Voltage - DIF_IN	V _{IHDIF}	Differential inputs (single-ended measurement)	600	800	1150	mV	1
Input Low Voltage - DIF_IN	V _{ILDIF}	Differential inputs (single-ended measurement)	V _{SS} - 300	0	300	mV	1
Input Common Mode Voltage - DIF_IN	V _{COM}	Common Mode Input Voltage	300		1000	mV	1
Input Amplitude - DIF_IN	V _{SWING}	Peak to Peak value	300		1450	mV	1
Input Slew Rate - DIF_IN	dv/dt	Measured differentially	0.4		8	V/ns	1,2
Input Leakage Current	I _{IN}	V _{IN} = V _{DD} , V _{IN} = GND	-5		5	uA	1
Input Duty Cycle	d _{tin}	Measurement from differential waveform	45		55	%	1
Input Jitter - Cycle to Cycle	J _{DIFIn}	Differential Measurement	0		125	ps	1

¹ Guaranteed by design and characterization, not 100% tested in production.² Slew rate measured through +/-75mV window centered around differential zero**Electrical Characteristics - DIF 0.7V Current Mode Differential Outputs**TA = T_{COM}; Supply Voltage VDD = 3.3 V +/-5%

PARAMETER	SYMBOL	CONDITIONS	MIN	TYP	MAX	UNITS	NOTES
Slew rate	Trf	Scope averaging on	1	2.4	4	V/ns	1, 2, 3
Slew rate matching	ΔTrf	Slew rate matching, Scope averaging on			20	%	1, 2, 4
Voltage High	V _{High}	Statistical measurement on single-ended signal using oscilloscope math function. (Scope averaging on)	660	800	850	mV	1
Voltage Low	V _{Low}		-150	20	150		1
Max Voltage	V _{max}	Measurement on single ended signal using absolute value. (Scope averaging off)		850	1150	mV	1
Min Voltage	V _{min}		-300				1
Vswing	V _{swing}	Scope averaging off	300			mV	1, 2
Crossing Voltage (abs)	V _{cross_abs}	Scope averaging off	250		550	mV	1, 5
Crossing Voltage (var)	ΔV _{cross}	Scope averaging off			140	mV	1, 6

¹ Guaranteed by design and characterization, not 100% tested in production. I_{REF} = VDD/(3xR_R). For R_R = 475Ω (1%), I_{REF} = 2.32mA. I_{OH} = 6 x I_{REF} and V_{OH} = 0.7V @ Z_O=50Ω (100Ω differential impedance).² Measured from differential waveform³ Slew rate is measured through the V_{swing} voltage range centered around differential 0V. This results in a +/-150mV window around differential 0V.⁴ Matching applies to rising edge rate for Clock and falling edge rate for Clock#. It is measured using a +/-75mV window centered on the average cross point where Clock rising meets Clock# falling. The median cross point is used to calculate the voltage thresholds the oscilloscope is to use for the edge rate calculations.⁵ V_{cross} is defined as voltage where Clock = Clock# measured on a component test board and only applies to the differential rising edge (i.e. Clock rising and Clock# falling).⁶ The total variation of all V_{cross} measurements in any particular system. Note that this is a subset of V_{cross_min/max} (V_{cross} absolute) allowed. The intent is to limit V_{cross} induced modulation by setting V_{cross_delta} to be smaller than V_{cross} absolute.**Electrical Characteristics - Current Consumption**TA = T_{COM}; Supply Voltage VDD = 3.3 V +/-5%

PARAMETER	SYMBOL	CONDITIONS	MIN	TYP	MAX	UNITS	NOTES
Operating Supply Current	I _{DD3.3OP}	All outputs active @100MHz, C _L = Full load;		300	375	mA	1
Powerdown Current	I _{DD3.3PD}	All diff pairs driven		NA		mA	1
	I _{DD3.3PDZ}	All differential pairs tri-stated		21	24	mA	1

¹ Guaranteed by design and characterization, not 100% tested in production.

Electrical Characteristics - Output Duty Cycle, Jitter, Skew and PLL CharacteristicsTA = T_{COM}; Supply Voltage VDD = 3.3 V +/-5%

PARAMETER	SYMBOL	CONDITIONS	MIN	TYP	MAX	UNITS	NOTES
PLL Bandwidth	BW	-3dB point in High BW Mode	2	3	4	MHz	1
		-3dB point in Low BW Mode	0.7	1	1.4	MHz	1
PLL Jitter Peaking	t _{JPEAK}	Peak Pass band Gain		1.5	2	dB	1
Duty Cycle	t _{DC}	Measured differentially, PLL Mode	45	49.5	55	%	1
Duty Cycle Distortion	t _{DCD}	Measured differentially, Bypass Mode @100MHz	-2	0	2	%	1,4
Skew, Input to Output	t _{pdBYP}	Bypass Mode, V _T = 50%	2500		4500	ps	1
	t _{pdPLL}	PLL Mode V _T = 50%	-250		250	ps	1
Skew, Output to Output	t _{sk3}	V _T = 50%		45	50	ps	1
Jitter, Cycle to cycle	t _{jyc-cyc}	PLL mode		25	50	ps	1,3
		Additive Jitter in Bypass Mode		25	50	ps	1,3

¹Guaranteed by design and characterization, not 100% tested in production.²I_{REF} = V_{DD}/(3xR_R). For R_R = 475Ω (1%), I_{REF} = 2.32mA. I_{OH} = 6 x I_{REF} and V_{OH} = 0.7V @ Z_O=50Ω.³Measured from differential waveform⁴Duty cycle distortion is the difference in duty cycle between the output and the input clock when the device is operated in bypass mode.**Electrical Characteristics - PCIe Phase Jitter Parameters**TA = T_{COM}; Supply Voltage VDD = 3.3 V +/-5%

PARAMETER	SYMBOL	CONDITIONS	MIN	TYP	MAX	UNITS	Notes
Phase Jitter, PLL Mode	t _{jphPCIeG1}	PCIe Gen 1		34	86	ps (p-p)	1,2,3
	t _{jphPCIeG2}	PCIe Gen 2 Lo Band 10kHz < f < 1.5MHz		1.1	3	ps (rms)	1,2
		PCIe Gen 2 High Band 1.5MHz < f < Nyquist (50MHz)		2.2	3.1	ps (rms)	1,2
	t _{jphPCIeG3}	PCIe Gen 3 (PLL BW of 2-4MHz, CDR = 10MHz)		0.4	1	ps (rms)	1,2,4,5
Additive Phase Jitter, Bypass Mode	t _{jphPCIeG1}	PCIe Gen 1		2	5	ps (p-p)	1,2,3
	t _{jphPCIeG2}	PCIe Gen 2 Lo Band 10kHz < f < 1.5MHz		0.5	0.6	ps (rms)	1,2,6
		PCIe Gen 2 High Band 1.5MHz < f < Nyquist (50MHz)		0.8	1	ps (rms)	1,2,6
	t _{jphPCIeG3}	PCIe Gen 3 (PLL BW of 2-4MHz, CDR = 10MHz)		0.35	0.5	ps (rms)	1,2,4,5,6

¹Applies to all outputs when driven by 932SQ420DGLF or equivalent.²See <http://www.pcisig.com> for complete specs³Sample size of at least 100K cycles. This figures extrapolates to 108ps pk-pk @ 1M cycles for a BER of 1-12.⁴Subject to final radification by PCI SIG.⁵Calculated from Intel-supplied Clock Jitter Tool v 1.6.4⁶For RMS figures, additive jitter is calculated by solving the following equation: (Additive jitter) = SQRT{(total jitter)² - (input jitter)²}

Clock Periods Differential Outputs with Spread Spectrum Enabled

Measurement Window		1 Clock	1us	0.1s	0.1s	0.1s	1us	1 Clock	Units	Notes
Symbol		Lg-	-SSC	-ppm error	0ppm	+ ppm error	+SSC	Lg+		
Definition		Absolute Period	Short-term Average	Long-Term Average	Period	Long-Term Average	Short-term Average	Period	Units	Notes
		Minimum Absolute Period	Minimum Absolute Period	Minimum Absolute Period	Nominal	Maximum	Maximum	Maximum		
DIF	DIF 100	9.87400	9.99900	9.99900	10.00000	10.00100	10.05130	10.17630	ns	1,2,3

Clock Periods Differential Outputs with Spread Spectrum Disabled

Measurement Window		1 Clock	1us	0.1s	0.1s	0.1s	1us	1 Clock	Units	Notes
Symbol		Lg-	-SSC	-ppm error	0ppm	+ ppm error	+SSC	Lg+		
Definition		Absolute Period	Short-term Average	Long-Term Average	Period	Long-Term Average	Short-term Average	Period	Units	Notes
		Minimum Absolute Period	Minimum Absolute Period	Minimum Absolute Period	Nominal	Maximum	Maximum	Maximum		
DIF	DIF 100	9.87400		9.99900	10.00000	10.00100		10.17630	ns	1,2,3

¹Guaranteed by design and characterization, not 100% tested in production.

²All Long Term Accuracy specifications are guaranteed with the assumption that the input clock complies with CK410B+/CK420BQ accuracy requirements. The 9DB1233 itself does not contribute to ppm error.

³ Driven by SRC output of main clock, PLL or Bypass mode

DIF Reference Clock			
Common Recommendations for Differential Routing	Dimension or Value	Unit	Figure
L1 length, route as non-coupled 50ohm trace	0.5 max	inch	1
L2 length, route as non-coupled 50ohm trace	0.2 max	inch	1
L3 length, route as non-coupled 50ohm trace	0.2 max	inch	1
R_s	33	ohm	1
R_t	49.9	ohm	1

Down Device Differential Routing			
L4 length, route as coupled microstrip 100ohm differential trace	2 min to 16 max	inch	1
L4 length, route as coupled stripline 100ohm differential trace	1.8 min to 14.4 max	inch	1

Differential Routing to PCI Express Connector			
L4 length, route as coupled microstrip 100ohm differential trace	0.25 to 14 max	inch	2
L4 length, route as coupled stripline 100ohm differential trace	0.225 min to 12.6 max	inch	2

Figure 1: Down Device Routing

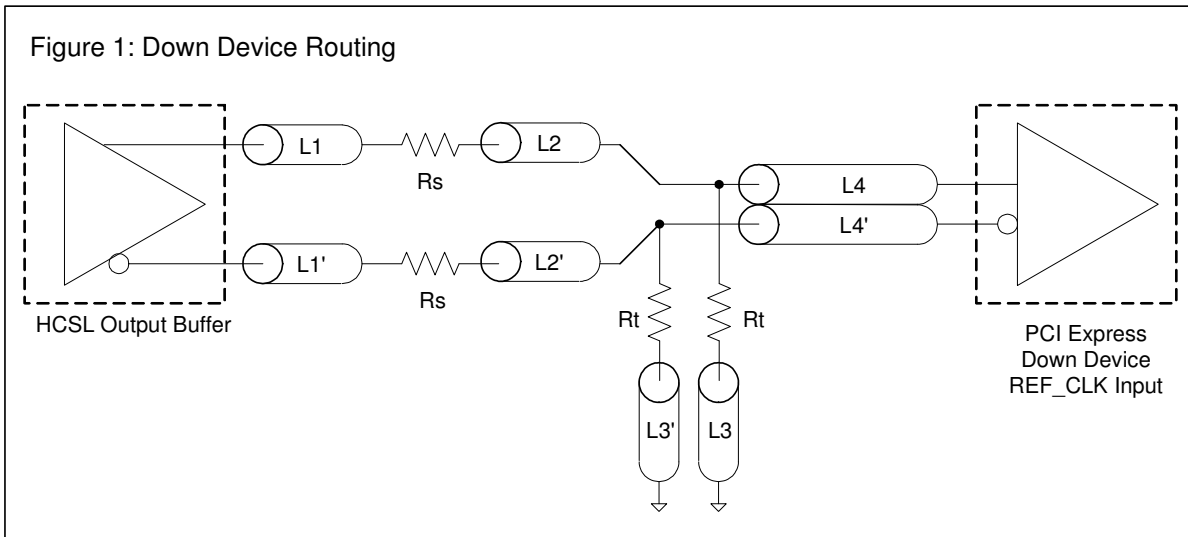
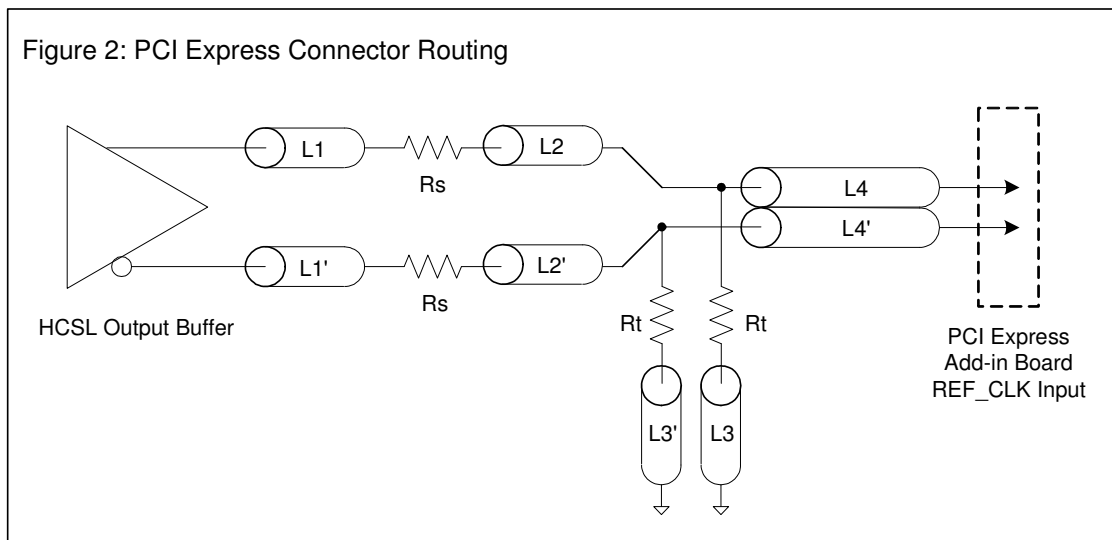

Figure 2: PCI Express Connector Routing



Alternative Termination for LVDS and other Common Differential Signals (figure 3)

V _{diff}	V _{p-p}	V _{cm}	R1	R2	R3	R4	Note
0.45v	0.22v	1.08	33	150	100	100	
0.58	0.28	0.6	33	78.7	137	100	
0.80	0.40	0.6	33	78.7	none	100	ICS874003i-02 input compatible
0.60	0.3	1.2	33	174	140	100	Standard LVDS

R1a = R1b = R1
 R2a = R2b = R2

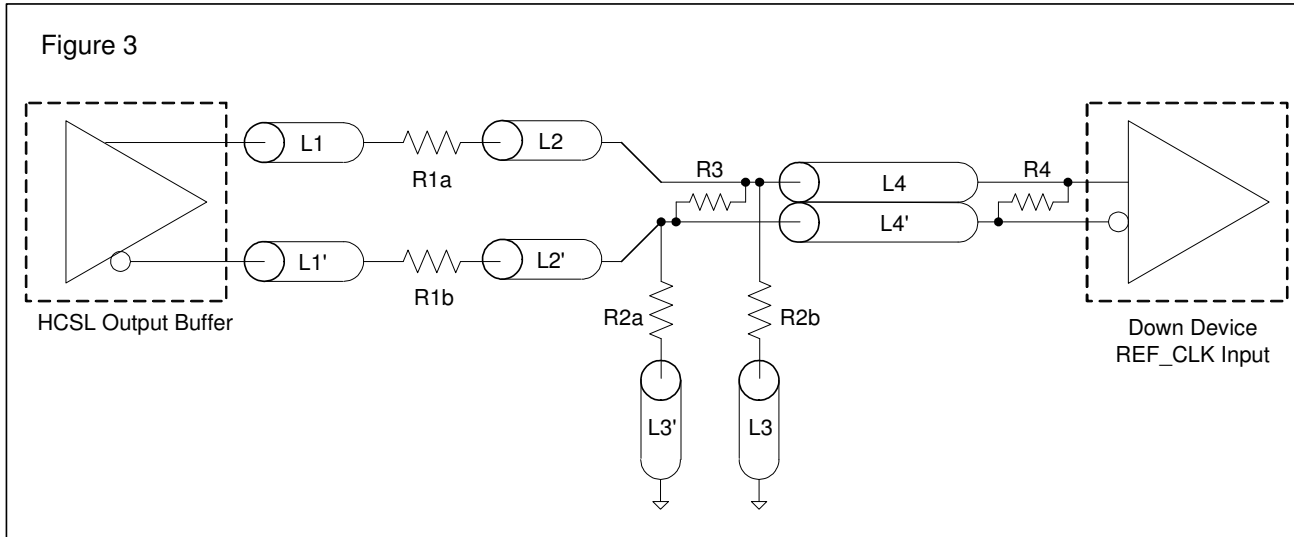

Cable Connected AC Coupled Application (figure 4)

Component	Value	Note
R5a, R5b	8.2K 5%	
R6a, R6b	1K 5%	
Cc	0.1 μF	
V _{cm}	0.350 volts	

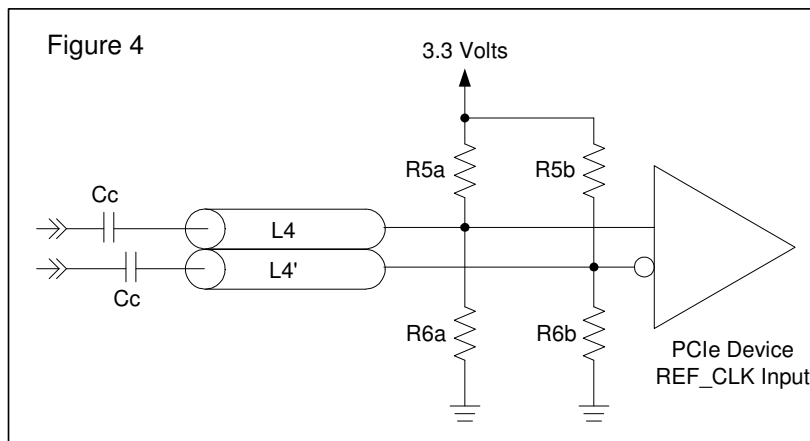

General SMBus serial interface information for the 9DB1233

How to Write:

- Controller (host) sends a start bit.
- Controller (host) sends the write address $DC_{(h)}$
- IDT clock will **acknowledge**
- Controller (host) sends the beginning byte location = N
- IDT clock will **acknowledge**
- Controller (host) sends the data byte count = X
- IDT clock will **acknowledge**
- Controller (host) starts sending **Byte N through Byte N + X - 1**
- IDT clock will **acknowledge** each byte **one at a time**
- Controller (host) sends a Stop bit

How to Read:

- Controller (host) will send start bit.
- Controller (host) sends the write address $DC_{(h)}$
- IDT clock will **acknowledge**
- Controller (host) sends the beginning byte location = N
- IDT clock will **acknowledge**
- Controller (host) will send a separate start bit.
- Controller (host) sends the read address $DD_{(h)}$
- IDT clock will **acknowledge**
- IDT clock will send the data byte count = X
- IDT clock sends **Byte N + X - 1**
- IDT clock sends **Byte 0 through byte X (if $X_{(h)}$ was written to byte 8).**
- Controller (host) will need to acknowledge each byte
- Controller (host) will send a not acknowledge bit
- Controller (host) will send a stop bit

Index Block Write Operation			
Controller (Host)		IDT (Slave/Receiver)	
T	starT bit		
Slave Address $DC_{(h)}$			
WR	WRite		
		ACK	
Beginning Byte = N			
		ACK	
Data Byte Count = X			
		ACK	
Beginning Byte N		X Byte	
			ACK
◊			◊
◊			◊
◊			◊
Byte N + X - 1			
		ACK	
P	stoP bit		

Index Block Read Operation			
Controller (Host)		IDT (Slave/Receiver)	
T	starT bit		
Slave Address $DC_{(h)}$			
WR	WRite		
		ACK	
Beginning Byte = N			
		ACK	
RT	Repeat starT		
Slave Address $DD_{(h)}$			
RD	ReaD		
		ACK	
		Data Byte Count = X	
ACK		X Byte	
ACK			Beginning Byte N
◊			◊
◊			◊
◊			◊
		Byte N + X - 1	
N	Not acknowledge		
P	stoP bit		

Note: Addresses show assumes pin 29 is low.

SMBus Table: Frequency Select Register

Byte 0	Pin #	Name	Control Function	Type	0	1	Default
Bit 7	-	HIGH_BW#	High or Low BW	RW	High BW	Low BW	Latch
Bit 6	-	BYPASS#/PLL	Bypass (non-PLL Mode) or PLL Mode	RW	Bypass	PLL	Latch
Bit 5	-	Reserved	Reserved	RW	Reserved		X
Bit 4	-	Reserved	Reserved	RW	Reserved		X
Bit 3	-	Reserved	Reserved	RW	Reserved		X
Bit 2	-	Reserved	Reserved	RW	Reserved		1
Bit 1	-	Reserved	Reserved	RW	Reserved		0
Bit 0	-	Reserved	Reserved	RW	Reserved		1

SMBus Table: Output Control Register

Byte 1	Pin #	Name	Control Function	Type	0	1	Default
Bit 7	43,42	DIF_7	Output Control (Disable = Hi-Z)	RW	Disable	Enable	1
Bit 6	38,37	DIF_6	Output Control (Disable = Hi-Z)	RW	Disable	Enable	1
Bit 5	27,28	DIF_5	Output Control (Disable = Hi-Z)	RW	Disable	Enable	1
Bit 4	22,23	DIF_4	Output Control (Disable = Hi-Z)	RW	Disable	Enable	1
Bit 3	19,20	DIF_3	Output Control (Disable = Hi-Z)	RW	Disable	Enable	1
Bit 2	14,15	DIF_2	Output Control (Disable = Hi-Z)	RW	Disable	Enable	1
Bit 1	11,12	DIF_1	Output Control (Disable = Hi-Z)	RW	Disable	Enable	1
Bit 0	6,7	DIF_0	Output Control (Disable = Hi-Z)	RW	Disable	Enable	1

SMBus Table: Output Control Register

Byte 2	Pin #	Name	Control Function	Type	0	1	Default
Bit 7	-	Reserved	Reserved	RW	Reserved		0
Bit 6	-	Reserved	Reserved	RW	Reserved		0
Bit 5	-	Reserved	Reserved	RW	Reserved		0
Bit 4	-	Reserved	Reserved	RW	Reserved		0
Bit 3	58,59	DIF_11	Output Control (Disable = Hi-Z)	RW	Disable	Enable	1
Bit 2	53,54	DIF_10	Output Control (Disable = Hi-Z)	RW	Disable	Enable	1
Bit 1	50,51	DIF_9	Output Control (Disable = Hi-Z)	RW	Disable	Enable	1
Bit 0	45,46	DIF_8	Output Control (Disable = Hi-Z)	RW	Disable	Enable	1

SMBus Table: Output Enable Readback

Byte 3	Pin #	Name	Control Function	Type	0	1	Default
Bit 7	43,42	OE7#	OE# Pin Readback	R	Enabled	Disabled	X
Bit 6	38,37	OE6#	OE# Pin Readback	R	Enabled	Disabled	X
Bit 5	27,28	OE5#	OE# Pin Readback	R	Enabled	Disabled	X
Bit 4	22,23	OE4#	OE# Pin Readback	R	Enabled	Disabled	X
Bit 3	19,20	OE3#	OE# Pin Readback	R	Enabled	Disabled	X
Bit 2	14,15	OE2#	OE# Pin Readback	R	Enabled	Disabled	X
Bit 1	11,12	OE1#	OE# Pin Readback	R	Enabled	Disabled	X
Bit 0	6,7	OE0#	OE# Pin Readback	R	Enabled	Disabled	X

SMBus Table: Output Enable Readback

Byte 4	Pin #	Name	Control Function	Type	0	1	Default
Bit 7	-	Reserved	Reserved	R	Reserved		0
Bit 6	-	Reserved	Reserved	R	Reserved		0
Bit 5	-	Reserved	Reserved	R	Reserved		0
Bit 4	-	Reserved	Reserved	R	Reserved		0
Bit 3	58,59	OE11#	Output Control (Disable = Hi-Z)	R	Enabled	Disabled	X
Bit 2	53,54	OE10#	Output Control (Disable = Hi-Z)	R	Enabled	Disabled	X
Bit 1	50,51	OE9#	Output Control (Disable = Hi-Z)	R	Enabled	Disabled	X
Bit 0	45,46	OE8#	Output Control (Disable = Hi-Z)	R	Enabled	Disabled	X

Note: For an output to be enabled, BOTH the Output Enable Bit and the OE# pin must be enabled. This means that the Output Enable Bit must be '1' and the corresponding OE# pin must be '0'.

SMBus Table: Vendor & Revision ID Register

Byte 5	Pin #	Name	Control Function	Type	0	1	Default
Bit 7	-	RID3	REVISION ID	R	-	-	0
Bit 6	-	RID2		R	-	-	0
Bit 5	-	RID1		R	-	-	1
Bit 4	-	RID0		R	-	-	0
Bit 3	-	VID3	VENDOR ID	R	-	-	0
Bit 2	-	VID2		R	-	-	0
Bit 1	-	VID1		R	-	-	0
Bit 0	-	VID0		R	-	-	1

SMBus Table: DEVICE ID

Byte 6	Pin #	Name	Control Function	Type	0	1	Default
Bit 7	-		Device ID 7 (MSB)	RW	Device ID is C0 Hex		1
Bit 6	-		Device ID 6	RW			1
Bit 5	-		Device ID 5	RW			0
Bit 4	-		Device ID 4	RW			0
Bit 3	-		Device ID 3	RW			0
Bit 2	-		Device ID 2	RW			0
Bit 1	-		Device ID 1	RW			0
Bit 0	-		Device ID 0	RW			0

SMBus Table: Byte Count Register

Byte 7	Pin #	Name	Control Function	Type	0	1	Default
Bit 7	-	BC7	Writing to this register configures how many bytes will be read back.	RW	-	-	0
Bit 6	-	BC6		RW	-	-	0
Bit 5	-	BC5		RW	-	-	0
Bit 4	-	BC4		RW	-	-	0
Bit 3	-	BC3		RW	-	-	0
Bit 2	-	BC2		RW	-	-	1
Bit 1	-	BC1		RW	-	-	1
Bit 0	-	BC0		RW	-	-	1

9DB1233
Twelve Output Differential Buffer for PCIe Gen3

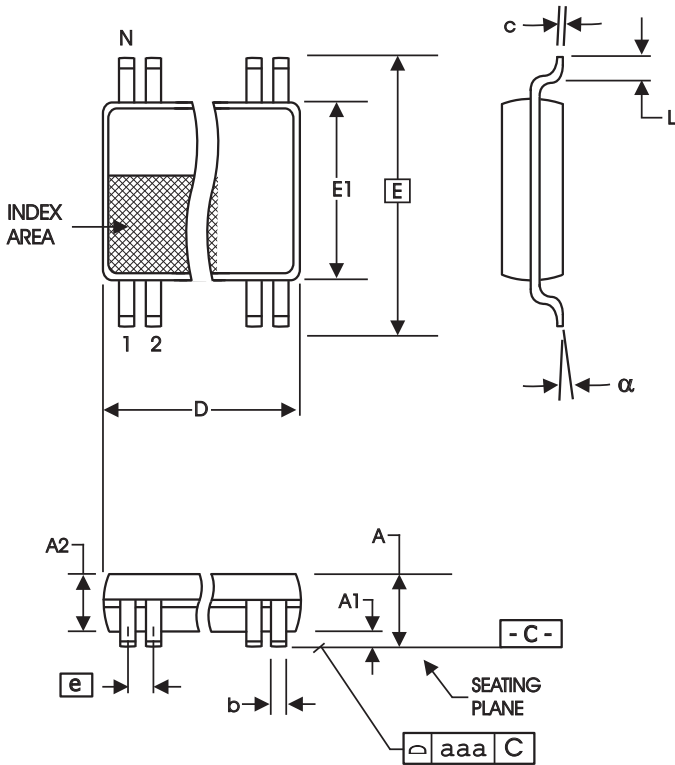

6.10 mm. Body, 0.50 mm. Pitch TSSOP
(240 mil) (20 mil)

SYMBOL	In Millimeters		In Inches	
	COMMON DIMENSIONS		COMMON DIMENSIONS	
	MIN	MAX	MIN	MAX
A	--	1.20	--	.047
A1	0.05	0.15	.002	.006
A2	0.80	1.05	.032	.041
b	0.17	0.27	.007	.011
c	0.09	0.20	.0035	.008
D	SEE VARIATIONS		SEE VARIATIONS	
E	8.10 BASIC		0.319 BASIC	
E1	6.00	6.20	.236	.244
e	0.50 BASIC		0.020 BASIC	
L	0.45	0.75	.018	.030
N	SEE VARIATIONS		SEE VARIATIONS	
alpha	0°	8°	0°	8°
aaa	--	0.10	--	.004

VARIATIONS

N	D mm.		D (inch)	
	MIN	MAX	MIN	MAX
64	16.90	17.10	.665	.673

Reference Doc.: JEDEC Publication 95, MO-153

10-0039

Ordering Information

Part / Order Number	Shipping Packaging	Package	Temperature
9DB1233AGLF	Tubes	64-pin TSSOP	0 to +70°C
9DB1233AGLFT	Tape and Reel	64-pin TSSOP	0 to +70°C

“LF” after the package code denotes the Pb-Free configuration, RoHS compliant.
 “A” is the device revision designator (will not correlate with the datasheet revision).

Revision History

Rev.	Issue Date	Who	Description	Page #
0.1	7/7/2010	RDW	Initial Release	-
A	7/12/2010	RDW	1. Changed 'PWD' to 'Default' in SMBus 2. Updated Electrical Tables 3. Move to Final	12,13
B	11/4/2010	RDW	1. Corrected Additive phase jitter calculation in PCIe phase jitter table 2. Added footnotes 5 and 6 to this table.	

Innovate with IDT and accelerate your future networks. Contact:

www.IDT.com

For Sales

800-345-7015
408-284-8200
Fax: 408-284-2775

For Tech Support

408-284-6578
pcclockhelp@idt.com

Corporate Headquarters

Integrated Device Technology, Inc.
6024 Silver Creek Valley Road
San Jose, CA 95138
United States
800 345 7015
+408 284 8200 (outside U.S.)

Asia Pacific and Japan

IDT Singapore Pte. Ltd.
1 Kallang Sector #07-01/06
KolamAyer Industrial Park
Singapore 349276
Phone: 65-6-744-3356
Fax: 65-6-744-1764

Europe

IDT Europe Limited
321 Kingston Road
Leatherhead, Surrey
KT22 7TU
England
Phone: 44-1372-363339
Fax: 44-1372-378851





Компания «ЭлектроПласт» предлагает заключение долгосрочных отношений при поставках импортных электронных компонентов на взаимовыгодных условиях!

Наши преимущества:

- Оперативные поставки широкого спектра электронных компонентов отечественного и импортного производства напрямую от производителей и с крупнейших мировых складов;
- Поставка более 17-ти миллионов наименований электронных компонентов;
- Поставка сложных, дефицитных, либо снятых с производства позиций;
- Оперативные сроки поставки под заказ (от 5 рабочих дней);
- Экспресс доставка в любую точку России;
- Техническая поддержка проекта, помощь в подборе аналогов, поставка прототипов;
- Система менеджмента качества сертифицирована по Международному стандарту ISO 9001;
- Лицензия ФСБ на осуществление работ с использованием сведений, составляющих государственную тайну;
- Поставка специализированных компонентов (Xilinx, Altera, Analog Devices, Intersil, Interpoint, Microsemi, Aeroflex, Peregrine, Syfer, Eurofarad, Texas Instrument, Miteq, Cobham, E2V, MA-COM, Hittite, Mini-Circuits, General Dynamics и др.);

Помимо этого, одним из направлений компании «ЭлектроПласт» является направление «Источники питания». Мы предлагаем Вам помощь Конструкторского отдела:

- Подбор оптимального решения, техническое обоснование при выборе компонента;
- Подбор аналогов;
- Консультации по применению компонента;
- Поставка образцов и прототипов;
- Техническая поддержка проекта;
- Защита от снятия компонента с производства.



Как с нами связаться

Телефон: 8 (812) 309 58 32 (многоканальный)

Факс: 8 (812) 320-02-42

Электронная почта: org@eplast1.ru

Адрес: 198099, г. Санкт-Петербург, ул. Калинина, дом 2, корпус 4, литера А.