

**Features**

- RoHS lead-free-solder and lead-solder-exempted products are available.
- Compliant to EN 50155, EN 50121-3-2.
- Compliant to EN 45545 (version V108 or later)
- Class I equipment
- Extremely wide input voltage ranges from 8 to 385 VDC, and 85 to 264 VAC, 47 to 440 Hz
- Input over- and undervoltage lockout
- Adjustable output voltage with remote on/off
- 1 or 2 outputs: SELV, no load, overload, and short-circuit proof
- Rectangular current limiting characteristic
- PCBs protected by lacquer
- Very high reliability

Safety-approved to the latest edition of IEC/EN 60950-1 and UL/CSA 60950-1.



**Description**

The S Series of DC-DC and AC-DC converters represents a broad and flexible range of power supplies for use in advanced electronic systems. Features include high efficiency, high reliability, low output voltage noise and excellent dynamic response to load/line changes. LS models can be powered by DC or AC with a wide-input frequency range (without PFC).

The converter inputs are protected against surges and transients. An input over- and undervoltage lockout circuitry disables the outputs, if the input voltage is outside of the specified range. Certain types include an inrush current limiter preventing circuit breakers and fuses from tripping at switch-on.

All outputs are open- and short-circuit proof, and are protected against overvoltages by means of built-in suppressor diodes. The output can be inhibited by a logic signal applied to pin 18 (i). If the inhibit function is not used, pin 18 must be connected with pin 14 to enable the outputs.

LED indicators display the status of the converter and allow for visual monitoring of the system at any time.

Full input-to-output, input-to-case, output-to-case, and output to output isolation is provided. The converters are designed, built, and safety-approved to the international safety standards IEC/EN 60950-1. They observe EN 50155 and EN 50121-3-2 and are particularly suitable for railway applications.

The case design allows operation at nominal load up to 71 °C in a free-air ambient temperature. If forced cooling is provided, the ambient temperature may exceed 71 °C, but the case temperature must remain below 95 °C under all conditions.

A temperature sensor generates an inhibit signal, which disables the outputs when the case temperature  $T_C$  exceeds the limit. The outputs are automatically re-enabled, when the temperature drops below the limit.

Various options are available to adapt the converters to individual applications.

The converters may either be plugged into a 19" DIN-rack system according to IEC 60297-3, or mounted to a chassis.

**Important:** For applications requiring compliance with IEC/EN 61000-3-2 (harmonic distortion), please use our LS4000 or LS5000 Series with incorporated power factor correction (PFC).

**Table of Contents**

	Page		Page
Description .....	1	Electromagnetic Compatibility (EMC) .....	15
Model Selection .....	2	Immunity to Environmental Conditions .....	17
Functional Description .....	4	Mechanical Data .....	18
Electrical Input Data .....	5	Safety and Installation Instructions .....	20
Electrical Output Data .....	8	Description of Options .....	23
Auxiliary Functions .....	12	Accessories .....	30

Copyright © 2017, Bel Power Solutions Inc. All rights reserved.

## Model Selection

Non-standard input/output configurations or special customer adaptations are available on request.

Table 1a: Models AS

Output 1		Output 2		Input Voltage	Effic. <sup>1</sup>	Input Voltage	Effic. <sup>1</sup>	Options <sup>4</sup>
$V_{O\ nom}$ [VDC]	$I_{O\ nom}$ [A]	$V_{O\ nom}$ [VDC]	$I_{O\ nom}$ [A]	$V_{i\ min} - V_{i\ max}$ 8 – 35 VDC	$\eta_{min}$ [%]	$V_{i\ min} - V_{i\ max}$ 14 – 70 VDC	$\eta_{min}$ [%]	
5.1	16	–	–	AS1001-9RG	76	BS1001-9RG	77	-7, P, D, V <sup>2</sup> , T, B, B1, non-G
12	8	–	–	AS1301-9RG	81	BS1301-9RG	83	-7, P, D, T, B, B1, non-G
15	6.5	–	–	AS1501-9RG	83	BS1501-9RG	85	
24	4.2	–	–	AS1601-9RG	84	BS1601-9RG	86	
12	4	12 <sup>3</sup>	4	AS2320-9RG	79	BS2320-9RG	80	-7, P, D, T, B, B1, non-G
15	3.2	15 <sup>3</sup>	3.2	AS2540-9RG	80	BS2540-9RG	82	
24	2	24 <sup>3</sup>	2	AS2660-9RG	80	BS2660-9RG	82	

Table 1b: Models BS, FS, CS

Output 1		Output 2		Input Voltage	Effic. <sup>1</sup>	Input Voltage	Effic. <sup>1</sup>	Options <sup>4</sup>
$V_{O\ nom}$ [VDC]	$I_{O\ nom}$ [A]	$V_{O\ nom}$ [VDC]	$I_{O\ nom}$ [A]	$V_{i\ min} - V_{i\ max}$ 20 – 100 VDC	$\eta_{min}$ [%]	$V_{i\ min} - V_{i\ max}$ 28 – 140 VDC	$\eta_{min}$ [%]	
5.1	16	–	–	FS1001-9ERG	77	CS1001-9ERG	77	-7, P, D, V <sup>2</sup> , T, B, B1, non-G
12	8	–	–	FS1301-9ERG	83	CS1301-9ERG	83	-7, P, D, T, B, B1, non-G
15	6.5	–	–	FS1501-9ERG	84	CS1501-9ERG	84	
24	4.2	–	–	FS1601-9ERG	86	CS1601-9ERG	85	
12	4	12 <sup>3</sup>	4	FS2320-9ERG	80	CS2320-9ERG	80	-7, P, D, T, B, B1, non-G
15	3.2	15 <sup>3</sup>	3.2	FS2540-9ERG	82	CS2540-9ERG	82	
24	2	24 <sup>3</sup>	2	FS2660-9ERG	82	CS2660-9ERG	82	

Table 1c: Models DS, ES, LS

Output 1		Output 2		Input Voltage	Effic. <sup>1</sup>	Input Voltage	Effic. <sup>1</sup>	Input Voltage	Effic. <sup>1</sup>	Options <sup>4</sup>
$V_{O\ nom}$ [VDC]	$I_{O\ nom}$ [A]	$V_{O\ nom}$ [VDC]	$I_{O\ nom}$ [A]	$V_{i\ min} - V_{i\ max}$ 44 – 220 VDC	$\eta_{min}$ [%]	$V_{i\ min} - V_{i\ max}$ 67 – 385 VDC	$\eta_{min}$ [%]	$V_{i\ min} - V_{i\ max}$ 88 – 372 VDC 85 – 264 VAC	$\eta_{min}$ [%]	
5.1	16	–	–	DS1001-9ERG	79	---	--	LS1001-9ERG	78	-7, P, D, V <sup>2</sup> , T, B, B1, non-G
12	8	–	–	DS1301-9ERG	84	ES1301-9ERG	83	LS1301-9ERG	83	-7, P, D, T, B, B1, non-G
12.84 <sup>5</sup>	7.5	–	–	DS1740-9ERG <sup>5</sup>	---	---	--	LS1740-9ERG <sup>5</sup>	---	
15	6.5	–	–	DS1501-9ERG	86	ES1501-9ERG	84	LS1501-9ERG	84	
24	4.2	–	–	DS1601-9ERG	86	ES1601-9ERG	86	LS1601-9ERG	85	
12	4	12 <sup>3</sup>	4	DS2320-9ERG	81	ES2320-9ERG	81	LS2320-9ERG	80	-7, P, D, T, B, B1, non-G
15	3.2	15 <sup>3</sup>	3.2	DS2540-9ERG	82	ES2540-9ERG	83	LS2540-9ERG	81	
24	2	24 <sup>3</sup>	2	DS2660-9ERG	83	ES2660-9ERG	83	LS2660-9ERG	81	
25.68 <sup>6</sup>	1.8	25.68 <sup>3 6</sup>	1.8	DS2740-9ERG <sup>6</sup>	---	---	--	LS2740-9ERG <sup>6</sup>	---	-7, T, B, B1, non-G

<sup>1</sup> Min. efficiency at  $V_{i\ nom}$ ,  $I_{O\ nom}$  and  $T_A = 25\ ^\circ\text{C}$ . Typical values are approximately 2% better.

<sup>2</sup> Option V is possible for 5.1 V output only and excludes option D.

<sup>3</sup> Second output semi-regulated

<sup>4</sup> Models FS, CS, DS, ES, LS are available as -7 or -9E.

<sup>5</sup> Battery loader for 12 V batteries.  $V_o$  is controlled by the battery temperature sensor (see *Accessories*) within 12.62 – 14.12 V. Options P, D, V are not available.

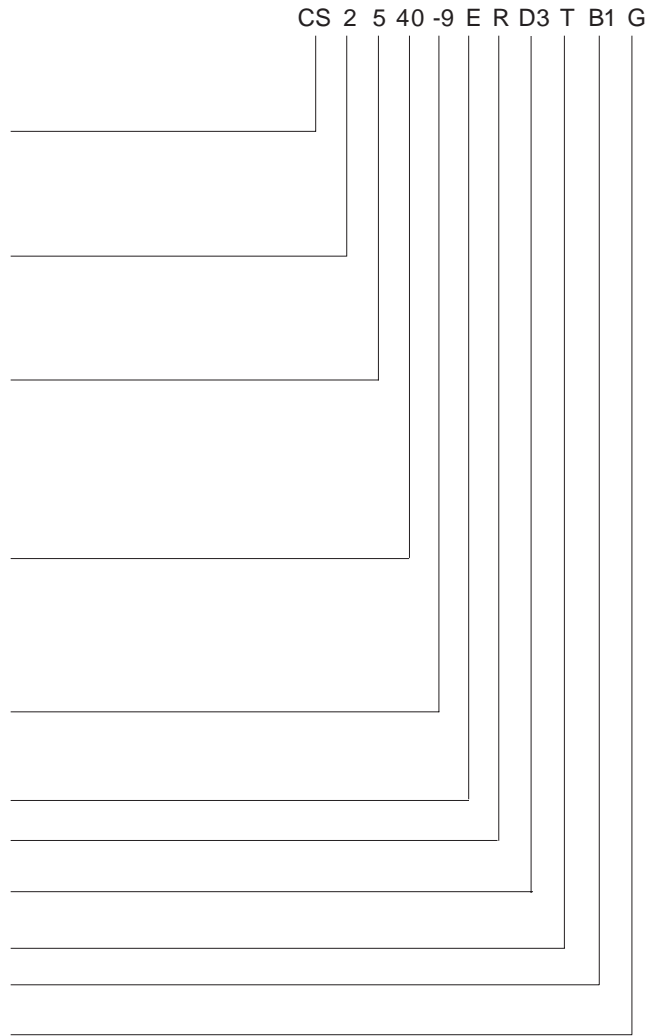
<sup>6</sup> Battery loader for 24 V (and 48 V batteries with series-connected outputs).  $V_o$  is controlled by the battery temperature sensor (see *Accessories*) within 25.25 – 28.25 V (50.5 – 56.5 V for 48 V batteries). Options P, D, and V are not available.

NFND: Not for new designs

Preferred for new designs

### Part Number Description

Operating input voltage $V_i$ :	
8 – 35 VDC .....	AS
14 – 70 VDC .....	BS
20 – 100 VDC .....	FS
28 – 140 VDC .....	CS
44 – 220 VDC .....	DS
67 – 385 VDC .....	ES
85 – 264 VAC or 88 – 372 VDC .....	LS
Number of outputs .....	1, 2
Nominal voltage of output 1 (main output) $V_{o1\ nom}$	
5.1 V .....	0, 1, 2
12 V .....	3
15 V .....	4, 5
24 V .....	6
Other voltages <sup>1</sup> .....	7, 8
Nominal voltage of output 2 $V_{o2\ nom}$	
None (single-output models) .....	00
12 V, 12 V .....	20
15 V, 15 V .....	40
24 V, 24 V .....	60
Other specifications or additional features <sup>1</sup> .....	21 – 99
Operational ambient temperature range $T_A$ :	
-25 to 71 °C .....	-7
-40 to 71 °C .....	-9
Other <sup>1</sup> .....	-0, -5, -6
Auxiliary functions and options:	
Inrush current limitation .....	E <sup>2</sup>
Output voltage control input .....	R <sup>3</sup>
Potentiometer (output voltage adjustment) .....	P <sup>3</sup>
Undervoltage monitor (D0 – DD, to be specified) .....	D <sup>4</sup>
ACFAIL signal (V2, V3, to be specified) .....	V <sup>4</sup>
Current share control .....	T
Cooling plate standard case .....	B or B1
Cooling plate for long case 220 mm <sup>1</sup> .....	B2 <sup>1</sup>
RoHS-compliant for all 6 substances <sup>5</sup> .....	G



<sup>1</sup> Customer-specific models

<sup>2</sup> Option E is mandatory for all -9 models, except AS and BS.

<sup>3</sup> Feature R excludes option P and vice versa. Option P is not available for battery charger models.

<sup>4</sup> Option D excludes option V and vice versa; option V is only available for models with 5.1 V single output.

**Note:** The sequence of options must follow the order above. This part number description is descriptive only; it is not intended for creating part numbers.

**Example:** CS2540-9ERD3TB1G: DC-DC converter, operating input voltage range 28 – 140 VDC, 2 electrically isolated outputs, each providing 15 V, 3.2 A, input current limiter E, control input R to adjust the output voltages, undervoltage monitor D3, current share feature T, cooling plate B1, and RoHS-compliant for all six substances.

### Product Marking

Basic type designation, applicable approval marks, CE mark, warnings, pin designation, patents and company logo, identification of LEDs, test sockets, and potentiometer.

Specific type designation, input voltage range, nominal output voltages and currents, degree of protection, batch no., serial no., and data code including production site, modification status, and date of production.

## Functional Description

The input voltage is fed via an input fuse, an input filter, a bridge rectifier (LS models only), and an inrush current limiter to the input capacitor  $C_1$ . This capacitor sources a single-transistor forward converter with a special clamping circuit and provides the power during the hold-up time.

Each output is powered by a separate secondary winding of the main transformer. The resultant voltages are rectified and

their ripple smoothed by a power choke and an output filter. The control logic senses the main output voltage  $V_{O1}$  and generates, with respect to the maximum admissible output currents, the control signal for the switching transistor of the forward converter.

The second output of double-output models is tracking to the main output, but has its own current limiting circuit. If the main output voltage drops due to current limitation, the second output voltage will fall as well and vice versa.

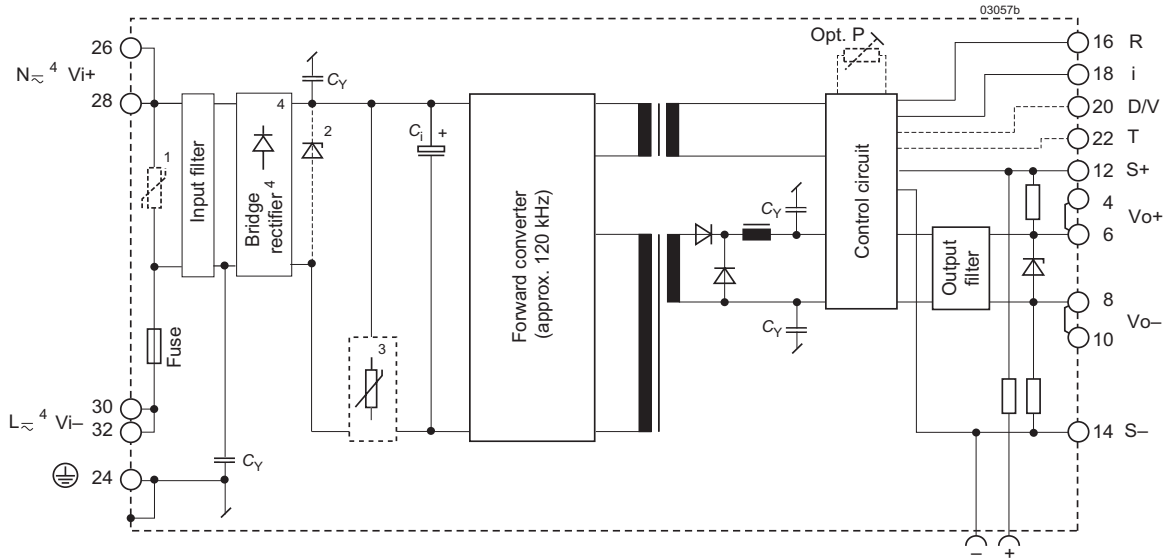


Fig. 1  
Block diagram of single-output converters

- 1 Transient suppressor (VDR)
- 2 Suppressor diode (AS, BS, FS models)
- 3 For CS, DS, ES, LS: Either NTC (-7 models only) or option E
- 4 LS models only

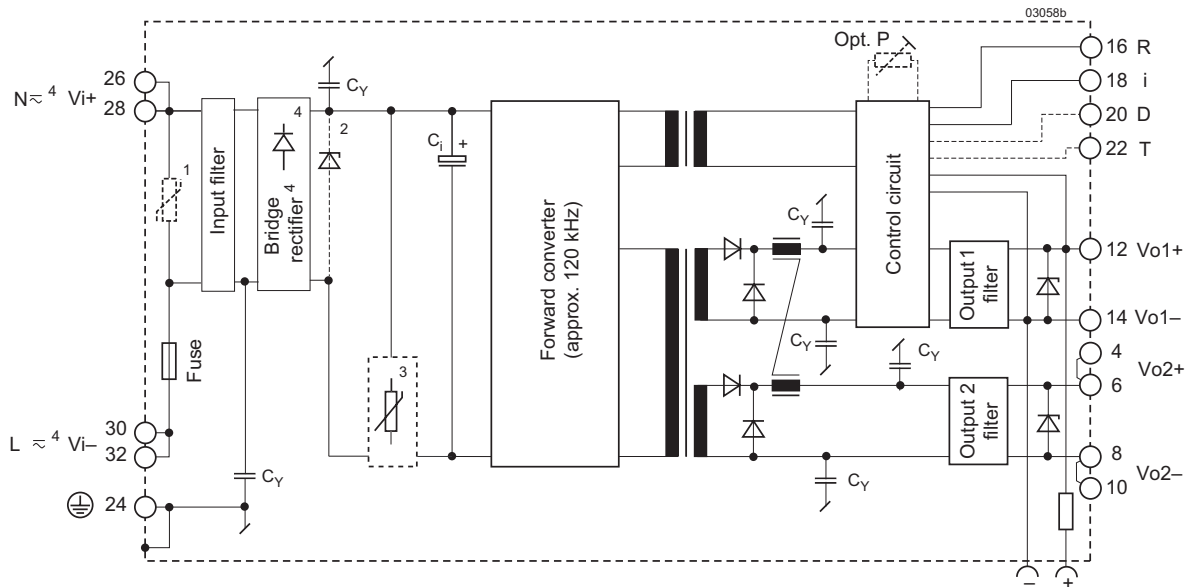


Fig. 2  
Block diagram of double-output models

- 1 Transient suppressor (VDR)
- 2 Suppressor diode (AS, BS, FS models)
- 3 For CS, DS, ES, LS: Either NTC (-7 models only) or option E
- 4 LS models only

## Electrical Input Data

### General Conditions

- $T_A = 25^\circ\text{C}$ , unless  $T_C$  is specified.
- Pin 18 connected to pin 14,  $V_o$  adjusted to  $V_{o\text{ nom}}$  (if option P); R input not connected.
- Sense line pins S+ and S– connected to Vo+ and Vo– respectively.

Table 2a: Input data

Input			AS			BS			FS			Unit
Characteristics		Conditions	min	typ	max	min	typ	max	min	typ	max	
$V_i$	Operating input voltage	$I_o = 0 - I_{o\text{ nom}}$	8		35	14		70	20		100	VDC
$V_{i\text{ nom}}$	Nominal input voltage	$T_{C\text{ min}} - T_{C\text{ max}}$		15			30			50		
$I_i$	Input current	$V_{i\text{ nom}}, I_{o\text{ nom}}^1$		7.5			4.3			2.6		A
$P_{i0}$	No-load input power	$V_{i\text{ min}} - V_{i\text{ max}}$			2.5			2.5			2.5	W
$P_{i\text{ inh}}$	Idle input power	unit inhibited			1.5			1.5			1.5	
$R_i$	Input resistance	$T_C = 25^\circ\text{C}$	65			100			70			mΩ
$R_{\text{NTC}}$	NTC resistance <sup>2</sup>		no NTC			no NTC			no NTC			
$C_i$	Input capacitance		832	1040		300	370		1200	1500		μF
$V_{i\text{ RFI}}$	Conducted input RFI	EN 55011		A			A			B		
	Radiated input RFI	$V_{i\text{ nom}}, I_{o\text{ nom}}$		A			A			A		
$V_{i\text{ abs}}$	Input voltage limits without damage		0		40	0		84	0		100	VDC

Table 2b: Input data

Input			CS			DS			ES			LS			Unit
Characteristics		Conditions	min	typ	max	min	typ	max	min	typ	max	min	typ	max	
$V_i$	Operating input voltage	$I_o = 0 - I_{o\text{ nom}}$ $T_{C\text{ min}} - T_{C\text{ max}}$	28		140	44		220	67		385	88		372	VDC
												85 <sup>4</sup>		264 <sup>4</sup>	VAC
$V_{i\text{ nom}}$	Nominal input voltage			60			110			220			310	VDC	
$I_i$	Input current	$V_{i\text{ nom}}, I_{o\text{ nom}}^1$		2.1			1.1			0.55			0.37	A	
$P_{i0}$	No-load input power	$V_{i\text{ min}} - V_{i\text{ max}}$			2.5			2.5			2.5			2.5	W
$P_{i\text{ inh}}$	Idle input power	unit inhibited			1.5			1.5			1.5			4.5	
$R_i$	Input resistance	$T_C = 25^\circ\text{C}$	150			170			180			480		mΩ	
$R_{\text{NTC}}$	NTC resistance <sup>2</sup>			1000			2000			4000		4000			
$C_i$	Input capacitance		960	1200		264	330		216	270		216	270	μF	
$V_{i\text{ RFI}}$	Conducted input RFI	EN 55011		B			B			B			B		
	Radiated input RFI	$V_{i\text{ nom}}, I_{o\text{ nom}}$		B			A			A			A		
$V_{i\text{ abs}}$	Input voltage limits without damage		0		154	0		400 <sup>3</sup>	0		400	-400		400	VDC

<sup>1</sup> Both outputs of double-output models are loaded with  $I_{o\text{ nom}}$ .

<sup>2</sup> Valid for -7 versions without option E (-9 versions exclude NTC). This is the nominal value at  $25^\circ\text{C}$  and applies to cold converters at initial switch-on cycle. Subsequent switch-on/off cycles increase the inrush current peak value.

<sup>3</sup> For 1 s max.

<sup>4</sup> Nominal frequency range is 50 – 60 Hz. Operating frequency range is 47 – 440 Hz (440 Hz for 115 V mains). For frequencies  $\geq 63$  Hz, refer to *Installation Instructions*.

### Input Transient Protection

A suppressor diode or a VDR (depending upon the input voltage range) together with the input fuse and a symmetrical input filter form an effective protection against high input transient voltages which, typically occur in most installations, but especially in battery-driven mobile applications.

Standard nominal battery voltages are: 12, 24, 36, 48, 60, 72, 110, and 220 V. Railway batteries are specified with a tolerance of -30% to +25%, with short excursions up to ±40%.

In certain applications, additional surges according to RIA 12 are specified. The power supply must not switch off during these surges, and since their energy can practically not be absorbed, an extremely wide input range is required. The ES input range for 110 V batteries has been designed and tested to meet this requirement.

### Input Fuse

A fuse mounted inside the converter protects against severe defects. This fuse may not fully protect the converter, when the input voltage exceeds 200 VDC. In applications, where the converters operate at source voltages above 200 VDC, an external fuse or a circuit breaker at system level should be installed.

Table 3: Fuse Specification

Model	Fuse type	Reference	Rating
AS	fast-blow <sup>1</sup>	Littlefuse 314	30 A, 125 V
BS	fast-blow <sup>1</sup>	Littlefuse 314	25 A, 125 V
FS	slow-blow <sup>2</sup>	Schurter SPT	16 A, 250 V
CS	slow-blow <sup>2</sup>	Schurter SPT	12.5 A, 250 V
DS	slow-blow <sup>2</sup>	Schurter SPT	8 A, 250 V
ES	slow-blow <sup>2</sup>	Schurter SPT	4 A, 250 V
LS	slow-blow <sup>2</sup>	Schurter SPT	4 A, 250 V

<sup>1</sup> Fuse size 6.3 × 32 mm    <sup>2</sup> Fuse size 5 × 20 mm



Fig. 3  
 Typical inrush current versus time at  $V_{i \max}$ ,  $R_{\text{ext}} = 0 \Omega$ .  
 For AS, BS, FS, and for application-related values, use the formula in this section to get realistic results.

### Inrush Current Limitation

The FS, CS, DS, ES, LS models incorporate an NTC resistor in the input circuitry, which at initial turn-on reduces the peak inrush current value by a factor of 5 – 10 such protecting connectors and switching devices from damage. Subsequent switch-on cycles within short periods will cause an increase of the peak inrush current value due to the warming-up of the NTC resistor. See also *Option E*.

The inrush current peak value (initial switch-on cycle) can be determined by following calculation; see also fig. 3:

$$I_{\text{inr p}} = \frac{V_{i \text{ source}}}{(R_{s \text{ ext}} + R_i + R_{\text{NTC}})}$$



Fig. 4  
 Equivalent input circuit

### Static Input Current Characteristic



Fig. 5  
 Typical input current versus relative input voltage

### Reverse Polarity

The converters (except LS models) are not protected against reverse polarity at the input to avoid unwanted power losses. In general, only the input fuse will trip.

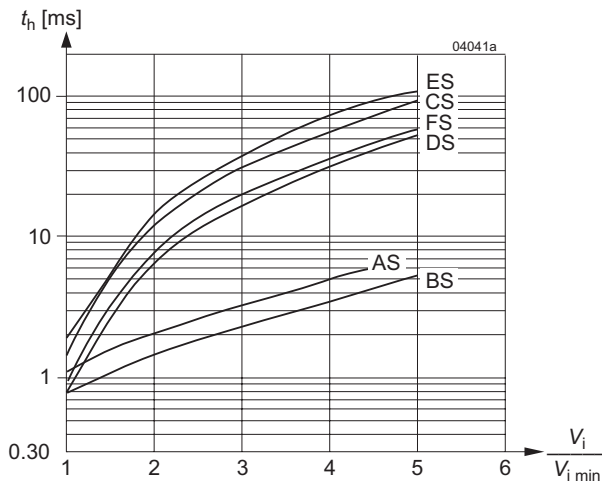
LS models are fully protected by the built-in bridge rectifier.



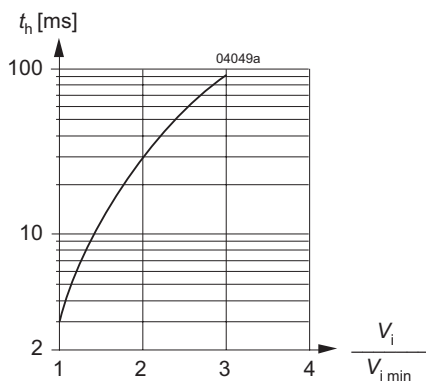
### Input Under-/Overvoltage Lockout

If the input voltage remains below approx.  $0.8 V_{i \min}$  or exceeds approx.  $1.1 V_{i \max}$ , an internally generated inhibit signal disables the output(s). When checking this function, the absolute maximum input voltage  $V_{i \text{ abs}}$  should be observed. Between  $V_{i \min}$  and the undervoltage lock-out level the output voltage may be below the value defined in table *Electrical Output data*.

### Hold-Up Time



**Fig. 6a**  
Typical hold-up time  $t_h$  versus relative DC input voltage.  $V_i/V_{i \min}$ . DC-DC converters require an external series diode in the input path, if other loads are connected to the same input supply lines.



**Fig. 6b**  
Typical hold-up time  $t_h$  versus relative AC input voltage (LS models)

## Electrical Output Data

General Conditions:

- $T_A = 25\text{ °C}$ , unless  $T_C$  is specified.
- Pin 18 (i) connected to pin 14 (S– or Vo1–), R input not connected,  $V_o$  adjusted to  $V_{o\text{ nom}}$  (option P),
- Sense line pins 12 (S+) and 14 (S–) connected to pins 4 (Vo1+) and 8 (Vo1–), respectively.

Table 5: Output data of single-output models

Model			AS – LS1001	AS – LS1301/1740 <sup>5</sup>	AS – LS1501	AS – LS1601	Unit				
Nom. output voltage			5.1 V	12 V / 12.84 V <sup>5</sup>	15 V	24 V					
Characteristics		Conditions	min	typ	max	min	typ	max			
$V_o$	Output voltage	$V_{i\text{ nom}}, I_{o\text{ nom}}$	5.07	5.13	11.93 <sup>5</sup>	12.07 <sup>5</sup>	14.91	15.09	23.86	24.14	V
$V_{o\text{ BR}}$	Overvoltage protection (suppressor diode) <sup>7</sup>		6.0		15.2/17.5 <sup>5</sup>		19.6		28.5		
$I_{o\text{ nom}}$	Output current nom. <sup>1</sup>	$V_{i\text{ min}} - V_{i\text{ max}}$ $T_{C\text{ min}} - T_{C\text{ max}}$	16		8/7.5 <sup>5</sup>		6.5		4.2		A
$I_{o\text{ L}}$	Output current limit	$V_{i\text{ min}} - V_{i\text{ max}}$	16.2		8.2/7.7 <sup>5</sup>		6.7		4.4		
$v_o$	Output noise <sup>3</sup>	Low frequency <sup>8</sup>	$V_{i\text{ nom}}, I_{o\text{ nom}}$		5		5		5		mV <sub>pp</sub>
		Switching frequ.	BW = 20 MHz		10		5		5		
		Total incl. spikes			50		50		60		
$\Delta V_{o\text{ u}}$	Static line regulation with respect to $V_{i\text{ nom}}$	$V_{i\text{ min}} - V_{i\text{ max}}$ $I_{o\text{ nom}}$	$\pm 15$		$\pm 20$		$\pm 25$		$\pm 30$		mV
$\Delta V_{o\text{ l}}$	Static load regulation <sup>10</sup>	$V_{i\text{ nom}}$ $(0.1 - 1) I_{o\text{ nom}}$	–20		–25		–30		–40		
$v_{o\text{ d}}$	Dynamic load regulat. <sup>3</sup>	Voltage deviation <sup>6</sup>	$\pm 100$		$\pm 100$		$\pm 100$		$\pm 100$		
$t_{\text{d}}$		Recovery time <sup>6</sup>	0.4		0.5		0.5		0.5		ms
$\alpha_{v_o}$	Temperature coefficient of output voltage <sup>4</sup>	$T_{C\text{ min}} - T_{C\text{ max}}$ $I_{o\text{ nom}}$	$\pm 0.02$		$\pm 0.02$		$\pm 0.02$		$\pm 0.02$		%/K

<sup>1</sup> If the output voltages are increased above  $V_{o\text{ nom}}$  through R-input control, option P setting, remote sensing or option T, the output currents should be reduced accordingly so that  $P_{o\text{ nom}}$  is not exceeded.

<sup>2</sup> See *Output voltage regulation*

<sup>3</sup> Measured according to IEC/EN 61204 with a probe according to annex A

<sup>4</sup> For battery charger applications, a defined negative temperature coefficient can be provided by using a temperature sensor (see *Accessories*), but we recommend choosing the special battery charger models.

<sup>5</sup> Especially designed for battery charging using the temperature sensor (see *Accessories*).  $V_o$  is set to  $12.84\text{ V} \pm 1\%$  (R-input open)

<sup>6</sup> See *Dynamic load regulation*

<sup>7</sup> Breakdown voltage of the incorporated suppressor diode (1 mA; 10 mA for 5 V output). Exceeding  $V_{o\text{ BR}}$  is dangerous for the suppressor diode.

<sup>8</sup> LS models only (twice the input frequency)



Table 6a: Output data of double-output models. General conditions as per table 5.

Model Nom. output voltage			AS – LS2320 2 x 12 V						AS – LS2540 2 x 15 V						Unit			
Characteristics			Conditions			Output 1			Output 2			Output 1				Output 2		
						min	typ	max	min	typ	max	min	typ	max		min	typ	max
$V_o$	Output voltage		$V_{i\text{nom}}, I_{o1\text{nom}}, I_{o2\text{nom}}$			11.93		12.07	11.82		12.18	14.91		15.09	14.78		15.22	V
$V_{o\text{BR}}^1$	Overvoltage protection (suppressor diode)					15.2			15.2			19.6			19.6			
$I_{o\text{nom}}$	Output current nom. <sup>2</sup>		$V_{i\text{min}} - V_{i\text{max}}$ $T_{C\text{min}} - T_{C\text{max}}$			4			4			3.2			3.2			A
$I_{oL}$	Output current limit <sup>9</sup>		$V_{i\text{min}} - V_{i\text{max}}$			4.2			4.2			3.4			3.4			
$v_o$	Output noise <sup>3</sup>	Low frequency <sup>8</sup>	$V_{i\text{nom}}, I_{o\text{nom}}$			5			5			5			5			mV <sub>pp</sub>
		Switching freq.	BW = 20 MHz			5			5			5			5			
		Total incl. spikes				40			40			50			50			
$\Delta V_{o\text{u}}$	Static line regulation with respect to $V_{i\text{nom}}$		$V_{i\text{min}} - V_{i\text{max}}$ $I_{o\text{nom}}$			±20			5			±25			5			mV
$\Delta V_{o\text{l}}$	Static load regulation		$V_{i\text{nom}}$ (0.1 – 1) $I_{o\text{nom}}$			–40			5			–50			5			
$v_{o\text{d}}$	Dynamic load regulat.	Voltage deviation <sup>4</sup>	$V_{i\text{nom}}, I_{o1\text{nom}} \leftrightarrow \frac{1}{2} I_{o1\text{nom}}$			±100			±150			±100			±150			
$t_{\text{d}}$		Recovery time <sup>4</sup>	$\frac{1}{2} I_{o2\text{nom}}$			0.2						0.2						ms
$\alpha_{v_o}$	Temperature coefficient of output voltage <sup>6</sup>		$T_{C\text{min}} - T_{C\text{max}}$ $I_{o\text{nom}}$			±0.02						±0.02						%/K

Table 6b: Output data of double-output models. General conditions as per table 5.

Model Nom. output voltage			AS – LS2660 / 2740 <sup>7</sup> 2 x 24 V / 2 x 25.68 V <sup>7</sup>									Unit
Characteristics			Conditions			Output 1			Output 2			
						min	typ	max	min	typ	max	
$V_o$	Output voltage		$V_{i\text{nom}}, I_{o1\text{nom}}, I_{o2\text{nom}}$			23.86 <sup>7</sup>		24.14 <sup>7</sup>	23.64 <sup>7</sup>		24.36 <sup>7</sup>	V
$V_{o\text{BR}}^1$	Overvoltage protection (suppressor diode)					28.5/34 <sup>7</sup>			28.5/34 <sup>7</sup>			
$I_{o\text{nom}}$	Output current nom. <sup>2</sup>		$V_{i\text{min}} - V_{i\text{max}}$ $T_{C\text{min}} - T_{C\text{max}}$			2/1.8 <sup>7</sup>			2/1.8 <sup>7</sup>			A
$I_{oL}$	Output current limit <sup>9</sup>		$V_{i\text{min}} - V_{i\text{max}}$			2.2/2.0 <sup>7</sup>			2.2/2.0 <sup>7</sup>			
$v_o$	Output noise <sup>3</sup>	Low frequency <sup>8</sup>	$V_{i\text{nom}}, I_{o\text{nom}}$			5			5			mV <sub>pp</sub>
		Switching freq.	BW = 20 MHz			5			5			
		Total incl. spikes				50			50			
$\Delta V_{o\text{u}}$	Static line regulation with respect to $V_{i\text{nom}}$		$V_{i\text{min}} - V_{i\text{max}}$ $I_{o\text{nom}}$			±30			5			mV
$\Delta V_{o\text{l}}$	Static load regulation		$V_{i\text{nom}}$ (0.1 – 1) $I_{o\text{nom}}$			–60			5			
$v_{o\text{d}}$	Dynamic load regulat.	Voltage deviation <sup>4</sup>	$V_{i\text{nom}}, I_{o1\text{nom}} \leftrightarrow \frac{1}{2} I_{o1\text{nom}}$			±100			±150			
$t_{\text{d}}$		Recovery time <sup>4</sup>	$\frac{1}{2} I_{o2\text{nom}}$			0.2						ms
$\alpha_{v_o}$	Temperature coefficient of output voltage <sup>6</sup>		$T_{C\text{min}} - T_{C\text{max}}$ $I_{o\text{nom}}$			±0.02						%/K

<sup>1</sup> Breakdown voltage of the incorporated suppressor diodes (1 mA). Exceeding  $V_{o\text{BR}}$  is dangerous for the suppressor diodes.

<sup>2</sup> If the output voltages are increased above  $V_{o\text{nom}}$  via R-input control, option P setting, remote sensing, or option T, the output currents should be reduced accordingly, so that  $P_{o\text{nom}}$  is not exceeded.

<sup>3</sup> Measured according to IEC/EN 61204 with a probe annex A

<sup>4</sup> See *Dynamic Load Regulation*

<sup>5</sup> See *Output Voltage Regulation of Double-Output Models*

<sup>6</sup> For battery charger applications, a defined negative temperature coefficient can be provided by using a temperature sensor; see *Accessories*.

<sup>7</sup> Especially designed for battery charging using the battery temperature sensor; see *Accessories*.

$V_{o1}$  is set to 25.68 V ±1% (R-input open-circuit).

<sup>8</sup> LS models only (twice the input frequency)

<sup>9</sup> Both outputs connected in series.

### Thermal Considerations

If a converter is located in free, quasi-stationary air (convection cooling) at the indicated maximum ambient temperature  $T_{A \max}$  (see table *Temperature specifications*) and is operated at its nominal input voltage and output power, the temperature measured at the *Measuring point of case temperature*  $T_C$  (see *Mechanical Data*) will approach the indicated value  $T_{C \max}$  after the warm-up phase. However, the relationship between  $T_A$  and  $T_C$  depends heavily upon the conditions of operation and integration into a system. The thermal conditions are influenced by input voltage, output current, airflow, and temperature of surrounding components and surfaces.  $T_{A \max}$  is therefore, contrary to  $T_{C \max}$ , an indicative value only.

**Caution:** The installer must ensure that under all operating conditions  $T_C$  remains within the limits stated in the table *Temperature specifications*.

**Notes:** Sufficient forced cooling or an additional heat sink allows  $T_A$  to be higher than 71 °C (e.g., 85 °C), as long as  $T_{C \max}$  is not exceeded. Details are specified in fig.7



Fig. 7  
Output current derating versus temperature for -7 and -9 models.

### Thermal Protection

A temperature sensor generates an internal inhibit signal, which disables the outputs, when the case temperature exceeds  $T_{C \max}$ . The outputs automatically recover, when the temperature drops below this limit.

Continuous operation under simultaneous extreme worst-case conditions of the following three parameters should be avoided: Minimum input voltage, maximum output power, and maximum temperature.

### Output Protection

Each output is protected against overvoltages, which could occur due to a failure of the internal control circuit. Voltage suppressor diodes (which under worst case condition may become a short circuit) provide the required protection. The suppressor diodes are not designed to withstand externally

applied overvoltages. Overload at any of the outputs will cause a shut-down of all outputs. A red LED indicates the overload condition.

**Note:**  $V_{o \text{ BR}}$  is specified in *Electrical Output Data*. If this voltage is exceeded, the suppressor diode generates losses and may become a short circuit.

### Parallel and Series Connection

Single- or double-output models with equal output voltage can be connected in parallel using option T (current sharing). If the T pins are interconnected, all converters share the output current equally.

Single-output models and/or main and second outputs of double-output models can be connected in series with any other (similar) output.

#### Notes:

- Parallel connection of double-output models should always include both, main and second output to maintain good regulation.
- Not more than 5 converters should be connected in parallel.
- Series connection of second outputs without involving their main outputs should be avoided, as regulation may be poor.
- The maximum output current is limited by the output with the lowest current limitation, if several outputs are connected in series.

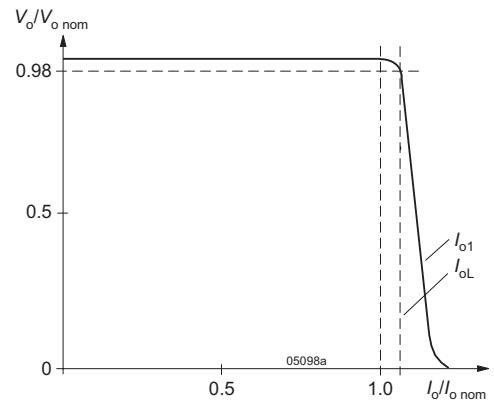


Fig. 8  
Output characteristic  $V_o$  versus  $I_o$  (single-output models or double-output models with parallel-connected outputs).



**Fig. 9**  
Typical dynamic load regulation of  $V_o$ .

### Output Voltage Regulation

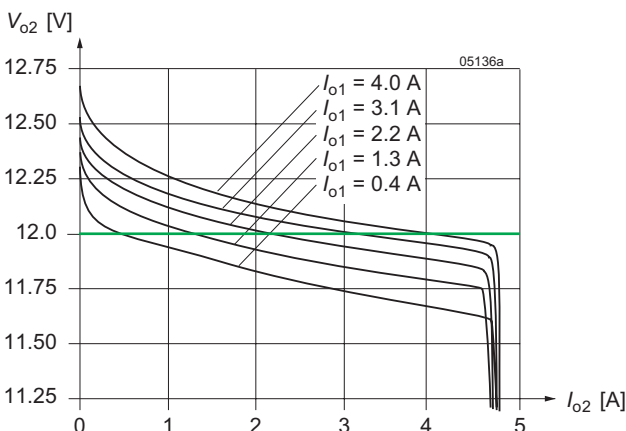
Figure 9 applies to single-output or double-output models with parallel-connected outputs.

For independent configuration, output 1 is under normal conditions regulated to  $V_{o,nom}$ , irrespective of the output currents.

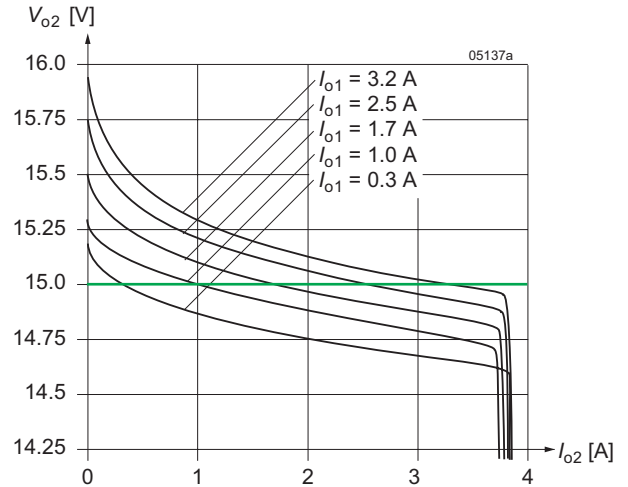
$V_{o2}$  depends upon the load distribution. If both outputs are loaded with more than 10% of  $I_{o,nom}$ , the deviation of  $V_{o2}$  remains within  $\pm 5\%$  of  $V_{o1}$ . Fig. 10 to 12 show the regulation depending on load distribution.

Two outputs of a double-output model connected in parallel behave like the output of a single-output model.

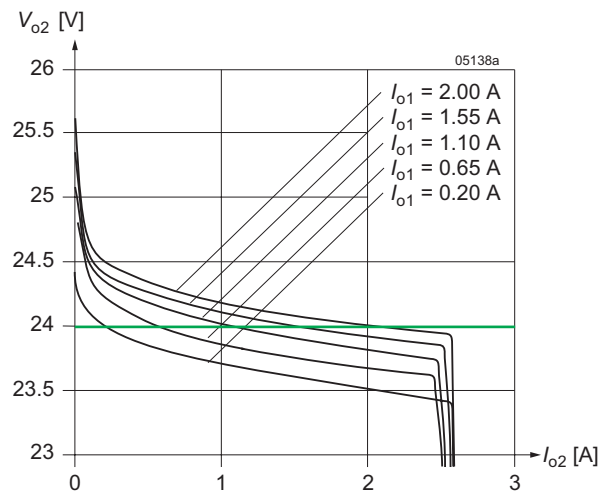
**Note:** If output 2 is not used, connect it in parallel with output 1! This ensures good regulation and efficiency.



**Fig. 10**  
Models with 2 outputs 12 V:  $V_{o2}$  versus  $I_{o2}$  with various  $I_{o1}$  (typ)



**Fig. 11**  
Models with 2 outputs 15 V:  $V_{o2}$  versus  $I_{o2}$  with various  $I_{o1}$  (typ)



**Fig. 12**  
Models with 2 outputs 24 V:  $V_{o2}$  versus  $I_{o2}$  with various  $I_{o1}$  (typ)

## Auxiliary Functions

### Inhibit for Remote On/Off

The outputs may be enabled or disabled by means of a logic signal (TTL, CMOS, etc.) applied between the inhibit input  $i$  (pin 18) and pin 14 ( $S-$  or  $Vo1-$ ). In systems with several converters, this feature can be used to control the activation sequence of the converters. If the inhibit function is not required, connect the inhibit pin 18 with pin 14!

**Note:** If pin 18 is not connected, the output is disabled.

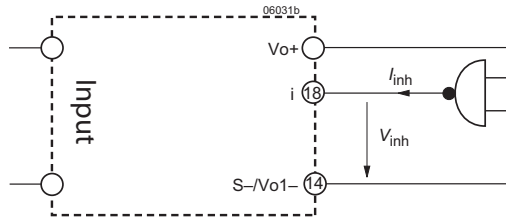


Fig. 13  
Definition of  $V_{inh}$  and  $I_{inh}$ .

Table 7: Inhibit characteristics

Characteristic Conditions				min	typ	max	Unit
$V_{inh}$	Inhibit voltage	$V_o = \text{on}$	$V_{i \min} - V_{i \max}$	-50		0.8	V
		$V_o = \text{off}$		2.4		50	
$I_{inh}$	Inhibit current		$V_{inh} = 0$			-400	$\mu\text{A}$
$t_r$	Rise time				30		ms
$t_f$	Fall time		depending on $I_o$				

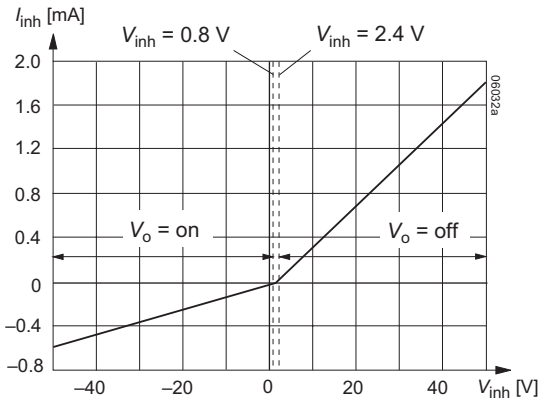


Fig. 14  
Typical inhibit current  $I_{inh}$  versus inhibit voltage  $V_{inh}$



Fig. 15  
Output response as a function of inhibit control

### Sense Lines (Single-Output Models)

**Important:** Sense lines must always be connected! Incorrectly connected sense lines may activate the overvoltage protection resulting in a permanent short-circuit of the output.

This feature allows for compensation of voltage drops across the connector contacts and if necessary, across the load lines. We recommend connecting the sense lines directly at the female connector.

To ensure correct operation, both sense lines ( $S+$ ,  $S-$ ) should be connected to their respective power outputs ( $Vo+$  and  $Vo-$ ), and the voltage difference between any sense line and its respective power output (as measured on the connector) should not exceed the following values:

Table 7: Maximum voltage compensation allowed using sense lines

Output voltage	Total voltage difference between sense lines and their respective outputs	Voltage difference between $Vo-$ and $S-$
5.1 V	<0.5 V	<0.25 V
12 V, 15 V, 24 V	<1.0 V	<0.25 V

### Programmable Output Voltage (R-Function)

As a standard feature, the converters offer an adjustable output voltage, identified by letter R in the type designation. The control input R (pin 16) accepts either a control voltage  $V_{ext}$  or a resistor  $R_{ext}$  to adjust the desired output voltage. When input R is not connected, the output voltage is set to  $V_{o \text{ nom}}$ .

a) Adjustment by means of an **external control voltage**  $V_{ext}$  between pin 16 (R) and pin 14 ( $S-$ ):

The control voltage range is 0 – 2.75 VDC and allows for an adjustment in the range of approximately 0 – 110% of  $V_{o \text{ nom}}$ .

$$V_{ext} \approx \frac{V_o}{V_{o \text{ nom}}} \cdot 2.5 \text{ V}$$

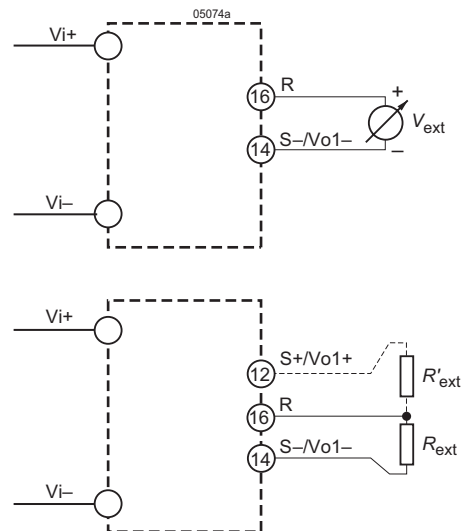


Fig. 16  
Output voltage control for single-output models

b) Adjustment by means of an **external resistor**:

Depending upon the value of the required output voltage, the resistor shall be connected

**either:** Between pin 16 and pin 14 to achieve an output voltage adjustment range of approximately 0 – 100% of  $V_{o\ nom}$ .

**or:** Between pin 16 and pin 12 to achieve an output voltage adjustment range of 100 – 110% of  $V_{o\ nom}$ .

**Warnings:**

- $V_{ext}$  shall never exceed 2.75 VDC.
- The value of  $R'_{ext}$  shall never be less than the lowest value as indicated in table  $R'_{ext}$  (for  $V_o > V_{o\ nom}$ ) to avoid damage to the converter!

**Notes:**

- The R-Function excludes option P (output voltage adjustment by potentiometer).
- If the output voltages are increased above  $V_{o\ nom}$  via R-input control, option P setting, remote sensing, or option T, the output currents should be reduced, so that  $P_{o\ nom}$  is not exceeded.
- With double-output models, the second output follows the voltage of the controlled main output.
- In case of parallel connection the output voltages should be individually set within a tolerance of 1 – 2%.

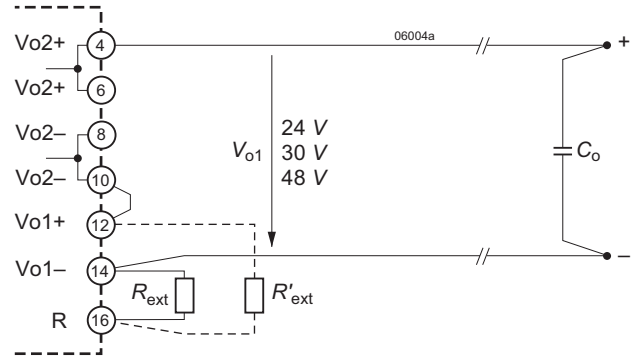


Fig. 17

**Double-output models:**

*Wiring of the R-input for output voltages 24 V, 30 V, or 48 V with both outputs in series. A ceramic capacitor ( $C_o$ ) across the load reduces ripple and spikes.*

The positive test socket is protected by a series resistor (see: *Functional Description, block diagrams*).

The voltage measured at the test jacks is slightly lower than the value at the output terminals.

**Test Sockets**

Test sockets (pin diameter 2 mm) for measuring the main output voltage  $V_o$  or  $V_{o1}$  are located at the front of the converter.

Table 8a:  $R_{ext}$  for  $V_o < V_{o\ nom}$ ; approximate values ( $V_{i\ nom}$ ,  $I_{o\ nom}$ , series E 96 resistors);  $R'_{ext}$  = not fitted

$V_{o\ nom} = 5.1\ V$		$V_{o\ nom} = 12\ V$			$V_{o\ nom} = 15\ V$			$V_{o\ nom} = 24\ V$		
$V_o$ [V]	$R_{ext}$ [kΩ]	$V_o$ [V] <sup>1</sup>		$R_{ext}$ [kΩ]	$V_o$ [V] <sup>1</sup>		$R_{ext}$ [kΩ]	$V_o$ [V] <sup>1</sup>		$R_{ext}$ [kΩ]
0.5	0.432	2	4	0.806	2	4	0.619	4	8	0.806
1.0	0.976	3	6	1.33	4	8	1.47	6	12	1.33
1.5	1.65	4	8	2	6	12	2.67	8	16	2.0
2.0	2.61	5	10	2.87	8	16	4.53	10	20	2.87
2.5	3.83	6	12	4.02	9	18	6.04	12	24	4.02
3.0	5.76	7	14	5.62	10	20	8.06	14	28	5.62
3.5	8.66	8	16	8.06	11	22	11	16	32	8.06
4.0	14.7	9	18	12.1	12	24	16.2	18	36	12.1
4.5	30.1	10	20	20	13	26	26.1	20	40	20
5.0	200	11	22	42.2	14	28	56.2	22	44	44.2

Table 8b:  $R'_{ext}$  for  $V_o > V_{o\ nom}$ ; approximate values ( $V_{i\ nom}$ ,  $I_{o\ nom}$ , series E 96 resistors);  $R_{ext}$  = not fitted

$V_{o\ nom} = 5.1\ V$		$V_{o\ nom} = 12\ V$			$V_{o\ nom} = 15\ V$			$V_{o\ nom} = 24\ V$		
$V_o$ [V]	$R'_{ext}$ [kΩ]	$V_o$ [V] <sup>1</sup>		$R'_{ext}$ [kΩ]	$V_o$ [V] <sup>1</sup>		$R'_{ext}$ [kΩ]	$V_o$ [V] <sup>1</sup>		$R'_{ext}$ [kΩ]
5.15	432	12.1	24.2	1820	15.2	30.4	1500	24.25	48.5	3320
5.2	215	12.2	24.4	931	15.4	30.8	768	24.5	49.0	1690
5.25	147	12.3	24.6	619	15.6	31.2	523	24.75	49.5	1130
5.3	110	12.4	24.8	475	15.8	31.6	392	25.0	50.0	845
5.35	88.7	12.5	25.0	383	16.0	32.0	316	25.25	50.5	698
5.4	75	12.6	25.2	316	16.2	32.4	267	25.5	51.0	590
5.45	64.9	12.7	25.4	274	16.4	32.8	232	25.75	51.5	511
5.5	57.6	12.8	25.6	243	16.5	33.0	221	26.0	52.0	442
		13.0	26.0	196				26.25	52.5	402
		13.2	26.4	169				26.4	52.8	383

<sup>1</sup> First column:  $V_o$  or  $V_{o1}$ ; second column: double-output models with series-connected outputs

**Display Status of LEDs**



LEDs "OK", "i" and " $I_{oL}$ " status versus input voltage  
Conditions:  $I_o \leq I_{o\ nom}$ ,  $T_c \leq T_{c\ max}$ ,  $V_{i\ inh} \leq 0.8\ V$   
 $V_{i\ uv}$  = undervoltage lock-out,  $V_{i\ ov}$  = overvoltage lock-out

LEDs "OK" and " $I_{oL}$ " status versus output current  
Conditions:  $V_{i\ min} - V_{i\ max}$ ,  $T_c \leq T_{c\ max}$ ,  $V_{i\ inh} \leq 0.8\ V$

LED "i" versus case temperature  
Conditions:  $V_{i\ min} - V_{i\ max}$ ,  $I_o \leq I_{o\ nom}$ ,  $V_{i\ inh} \leq 0.8\ V$

LED "i" versus  $V_{i\ inh}$   
Conditions:  $V_{i\ min} - V_{i\ max}$ ,  $I_o \leq I_{o\ nom}$ ,  $T_c \leq T_{c\ max}$

Fig. 18  
LED indicators

**Battery Charging / Temperature Sensor**

All converters with an R-input are suitable for battery charger applications, but we recommend choosing the models especially designed for this application DK/LK1740 or DK/LK2740; see *Model Selection*.

For optimal battery charging and life expectancy of the battery an external temperature sensor can be connected to the R-input. The sensor is mounted as close as possible to the battery and adjusts the output voltage according to the battery temperature.

Depending upon cell voltage and the temperature coefficient of the battery, different sensor types are available, see *Accessories*.

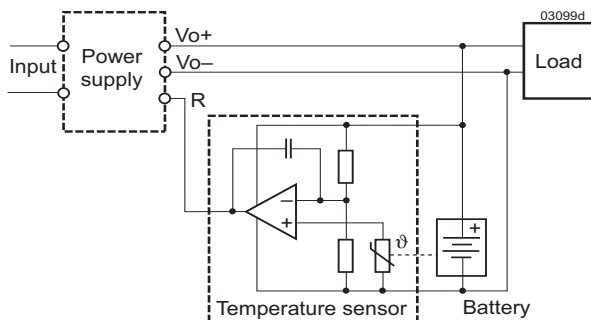


Fig. 19  
Connection of a temperature sensor

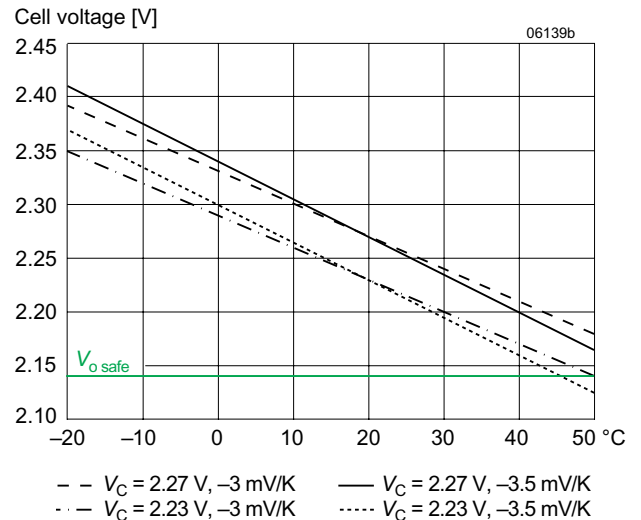


Fig. 20  
Trickle charge voltage versus temperature for defined temperature coefficient.  $V_{o\ nom}$  is the output voltage with open R-input.



## Electromagnetic Compatibility (EMC)

A metal oxide VDR together with the input fuse and an input filter form an effective protection against high input transient

voltages, which typically occur in most installations. The converters have been successfully tested to the following specifications:

## Electromagnetic Immunity

Table 9: Electromagnetic immunity (type tests)

U ↑ ⇄ ↓ menon	Standard	Level	Coupling mode <sup>1</sup>	Value applied	Waveform	Source imped.	Test procedure	In oper.	Perf. crit. <sup>2</sup>
Supply related surge	RIA 12 <sup>3</sup>	A <sup>4</sup>	+i/-i	3.5 V <sub>Bat</sub>	2/20/2 ms	0.2 Ω	1 positive surge	yes	A
		B		1.5 V <sub>Bat</sub>	0.1/1/0.1 s				
Direct transients		C	+i/-i, -i/c	960 V <sub>p</sub>	10/100 μs	5 Ω	5 pos and 5 neg. pulses	yes	B
		D <sup>3</sup>		1800 V <sub>p</sub>	5/50 μs				
		E		3600 V <sub>p</sub>	0.5/5 μs	100 Ω			
		F		4800 V <sub>p</sub>	0.1/1 μs				
		G <sup>3</sup>		8400 V <sub>p</sub>	0.05/0.1 μs				
				H	+o/c, -o/c				
J	3600 V <sub>p</sub>	0.5/5 μs							
K	4800 V <sub>p</sub>	0.1/1 μs							
L	8400 V <sub>p</sub>	0.05/0.1 μs							
Indirect coupled transients									
Electrostatic discharge (to case)	IEC/EN 61000-4-2	4 <sup>5</sup>	contact discharge	±8000 V <sub>p</sub>	1/50 ns	330 Ω 150 pF	10 positive and 10 negative discharges	yes	A
			air discharge	±15000 V <sub>p</sub>					
Electromagnetic field	IEC/EN 61000-4-3	x <sup>6</sup>	antenna	20 V/m	AM 80% /1 kHz	n.a.	80 – 1000 MHz	yes	A
		7	antenna	10 V/m			1400 – 2000 MHz		
				5 V/m			2000 – 2500 MHz		
				3 V/m			5100 – 6000 MHz		
Electrical fast transients/burst	IEC/EN 61000-4-4	3	capacitive, o/c	±2000 V <sub>p</sub>	bursts of 5/50 ns 2.5/5 kHz over 15 ms; burst period: 300 ms	50 Ω	60 s positive 60 s negative transients per coupling mode	yes	A
		4 <sup>8</sup>	±i/c, +i/-i direct	±4000 V <sub>p</sub>					
Surges	IEC/EN 61000-4-5	3 <sup>9</sup>	±i/c	±2000 V <sub>p</sub>	1.2/50 μs	12 Ω	5 pos. and 5 neg. surges per coupling mode	yes	A
			+i/-i	±1000 V <sub>p</sub>		2 Ω			
Conducted disturbances	IEC/EN 61000-4-6	3 <sup>10</sup>	i, o, signal wires	10 VAC (140 dBμV)	AM 80% 1 kHz	150 Ω	0.15 – 80 MHz	yes	A

<sup>1</sup> i = input, o = output, c = case

<sup>2</sup> A = normal operation, no deviation from specs.; B = temporary loss of function or deviation from specs possible

<sup>3</sup> RIA 12 covers or exceeds IEC 60571-1 and EN 50155:1995. Surge D corresponds to EN 50155:2001, waveform A; surge G corresponds to EN 50155:2001, waveform B

<sup>4</sup> Only met with extended input voltage range of CS (for 48 V battery) and ES (for 110 V battery) model types. Such CS models are available on customer's request. Standard DS models types (on 110 V battery) will shut down during the surge and recover automatically.

<sup>5</sup> Exceeds EN 50121-3-2:2015 table 6.3 and EN 50121-4:2016 table 2.4.

<sup>6</sup> Corresponds to EN 50121-3-2:2015 table 6.1 and exceeds EN 50121-4:2016 table 2.1.

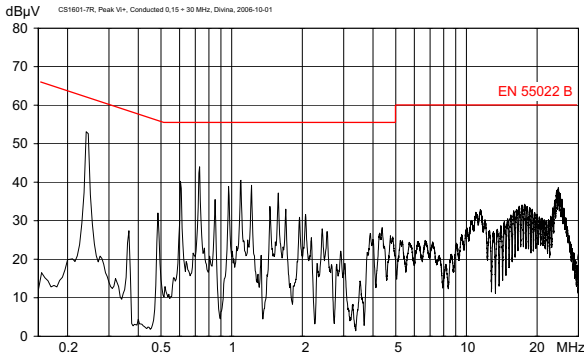
<sup>7</sup> Corresponds to EN 50121-3-2:2015 table 6.2 and EN 50121-4:2016 table 2.2 (compliance with digital communication devices).

<sup>8</sup> Corresponds or exceeds EN 50121-3-2:2015 table 4.2 and EN 50121-4:2016 table 4.2.

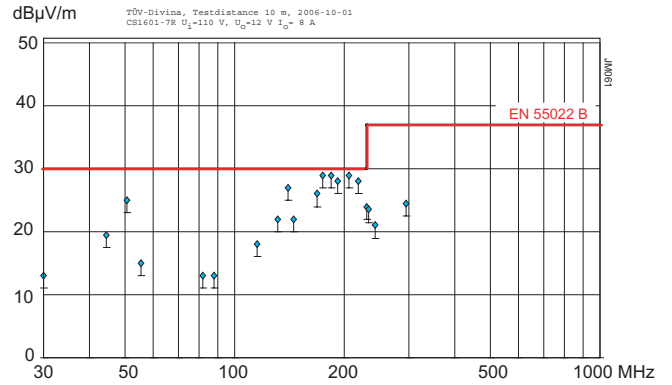
<sup>9</sup> Covers or exceeds EN 50121-3-2:2015 table 4.3 and EN 50121-4:2016 table 4.3.

<sup>10</sup> Corresponds to EN 50121-3-2:2015 table 4.1 and EN 50121-4:2016 table 4.1 (radio frequency common mode).

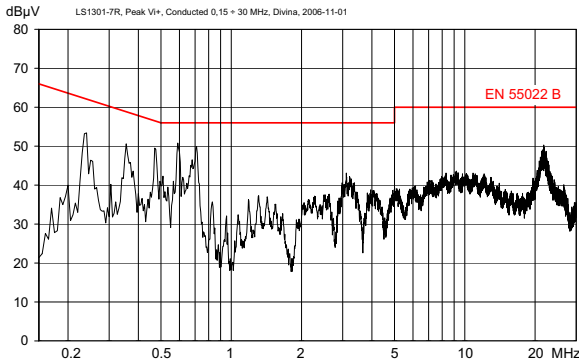
**Electromagnetic Emissions**



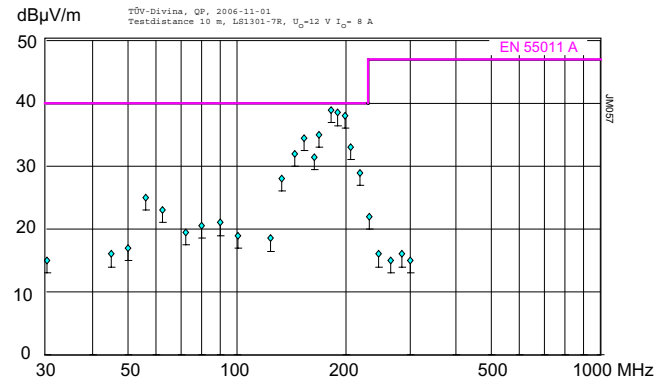
**Fig. 21a**  
Typical conducted emissions (peak) at the positive input according to EN 55011/32, measured at  $V_{i\text{nom}}$  and  $I_{o\text{nom}}$  (CS1601-7R)



**Fig. 22a**  
Radiated emissions according to EN 55011/32, antenna 10 m distance, measured at  $V_{i\text{nom}}$  and  $I_{o\text{nom}}$  (CS1601-7R)



**Fig. 21b**  
Typical conducted emissions (peak) at the positive input according to EN 55011/32, measured at  $V_{i\text{nom}}$  and  $I_{o\text{nom}}$  (LS1301-7R).



**Fig. 22b**  
Radiated emissions according to EN 55011/32, antenna 10 m distance, measured at  $V_{i\text{nom}}$  and  $I_{o\text{nom}}$  (LS1301-7R)

## Immunity to Environmental Conditions

Table 10: Mechanical and climatic stress

Test	Method	Standard	Test Conditions	Status
Cab	Damp heat steady state	IEC/EN 60068-2-78 MIL-STD-810D sect. 507.2	Temperature: 40 <sup>±2</sup> °C Relative humidity: 93 <sup>+2/-3</sup> % Duration: 56 days	Converter not operating
Kb	Salt mist, cyclic (sodium chloride NaCl solution)	IEC/EN 60068-2-52	Concentration: 5% (30 °C) for 2 h Storage: 40 °C, 93% rel. humidity Duration: 3 cycles of 22 h	Converter not operating
Fc	Vibration (sinusoidal)	IEC/EN 60068-2-6 MIL-STD-810D sect. 514.3	Acceleration amplitude: 0.35 mm (10 – 60 Hz) 5 g <sub>n</sub> = 49 m/s <sup>2</sup> (60 – 2000 Hz) Frequency (1 Oct/min): 10 – 2000 Hz Test duration: 7.5 h (2.5 h each axis)	Converter operating
Fh	Random vibration broad band (digital control)	IEC/EN 60068-2-64	Acceleration spectral density: 0.05 g <sub>n</sub> <sup>2</sup> /Hz Frequency band: 8 – 500 Hz Acceleration magnitude: 4.9 g <sub>n,rms</sub> Test duration: 1.5 h (0.5 h each axis)	Converter operating
Ea	Shock (half-sinusoidal)	IEC/EN 60068-2-27 MIL-STD-810D sect. 516.3	Acceleration amplitude: 50 g <sub>n</sub> = 490 m/s <sup>2</sup> Bump duration: 11 ms Number of bumps: 18 (3 each direction)	Converter operating
--	Shock	EN 50155:2007 sect. 12.2.11, EN 61373 sect. 10, class B, body mounted <sup>1</sup>	Acceleration amplitude: 5.1 g <sub>n</sub> Bump duration: 30 ms Number of bumps: 18 (3 in each direction)	Converter operating
--	Simulated long life testing at increased random vibration levels	EN 50155:2007 sect. 12.2.11, EN 61373 sect. 8 and 9, class B, body mounted <sup>1</sup>	Acceleration spectral density: 0.02 g <sub>n</sub> <sup>2</sup> /Hz Frequency band: 5 – 150 Hz Acceleration magnitude: 0.8 g <sub>n,rms</sub> Test duration: 15 h (5 h in each axis)	Converter operating

<sup>1</sup> Body mounted = chassis of a railway coach

## Temperatures

Table 11: Temperature specifications, values given are for an air pressure of 800 – 1200 hPa (800 – 1200 mbar)

Temperature			-5 <sup>2</sup>		-6 <sup>2</sup>		-7 (option)		-9		Unit
Characteristics	Conditions		min	max	min	max	min	max	min	max	
T <sub>A</sub>	Ambient temperature	Converter operating	-25	50	-25	60	-25	71	-40	71	°C
T <sub>C</sub>	Case temperature <sup>1</sup>		-25	85 <sup>1</sup>	-25	90 <sup>1</sup>	-25	95 <sup>1</sup>	-40	95 <sup>1</sup>	
T <sub>S</sub>	Storage temperature	Not operating	-40	85	-40	85	-40	85	-55	85	

<sup>1</sup> Overtemperature lockout at T<sub>C</sub> > 95 °C

<sup>2</sup> Customer-specific models

## Reliability and Device Hours

Table 12: MTBF calculated according to MIL-HDBK 217F

Values at specified case temperature	Model	Ground benign 40 °C	Ground fixed		Ground mobile 50 °C	Unit
			40 °C	70 °C		
MTBF <sup>1</sup>	AS – LS	500 000	150 000	80 000	50 000	h
Device hours <sup>2</sup>	AS – LS	500 000				

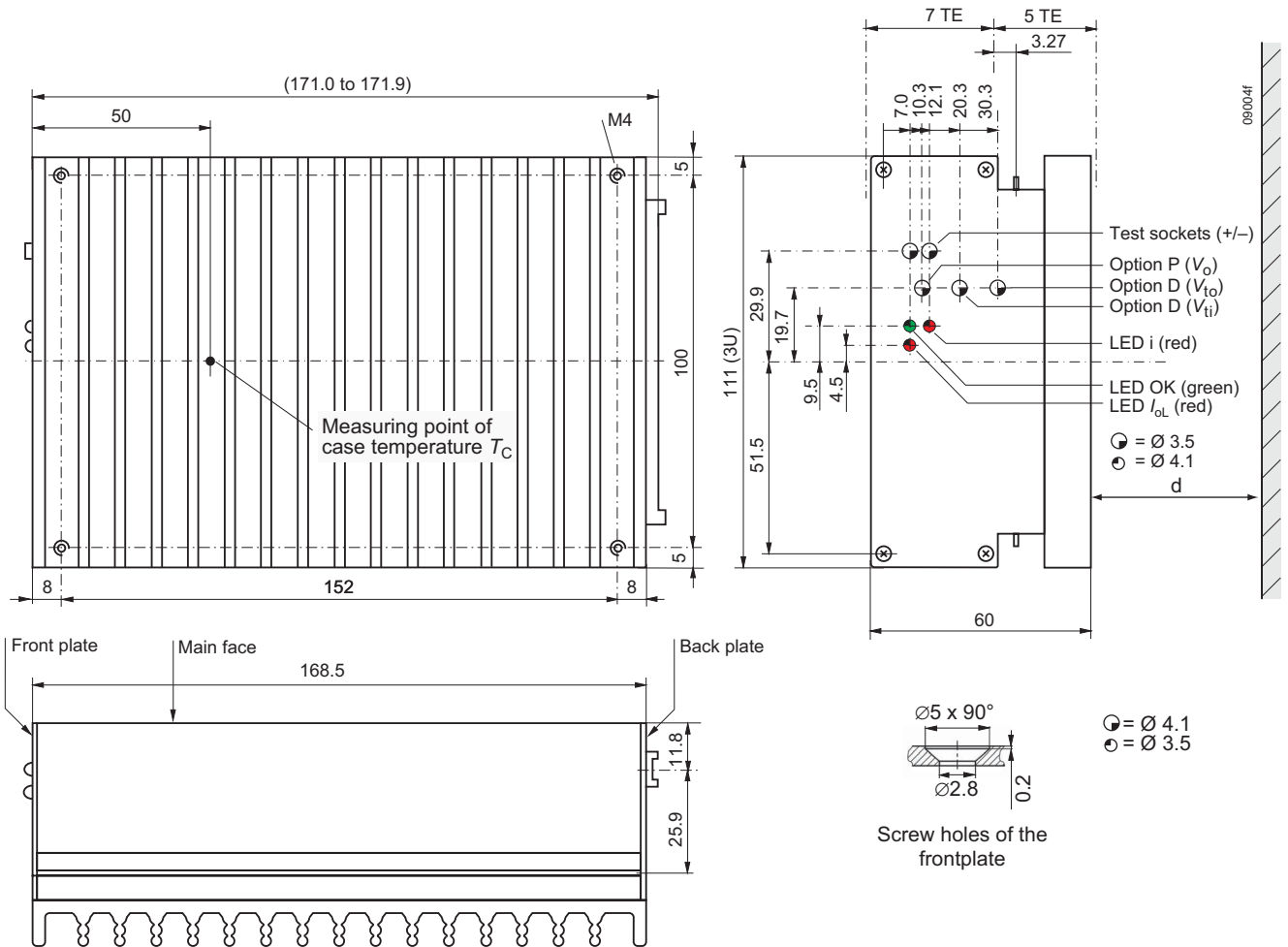
<sup>1</sup> Calculated according to MIL-HDBK-217F

<sup>2</sup> Statistic values, based on an average of 4300 working hours per year, over 3 years in general field use.



### Mechanical Data

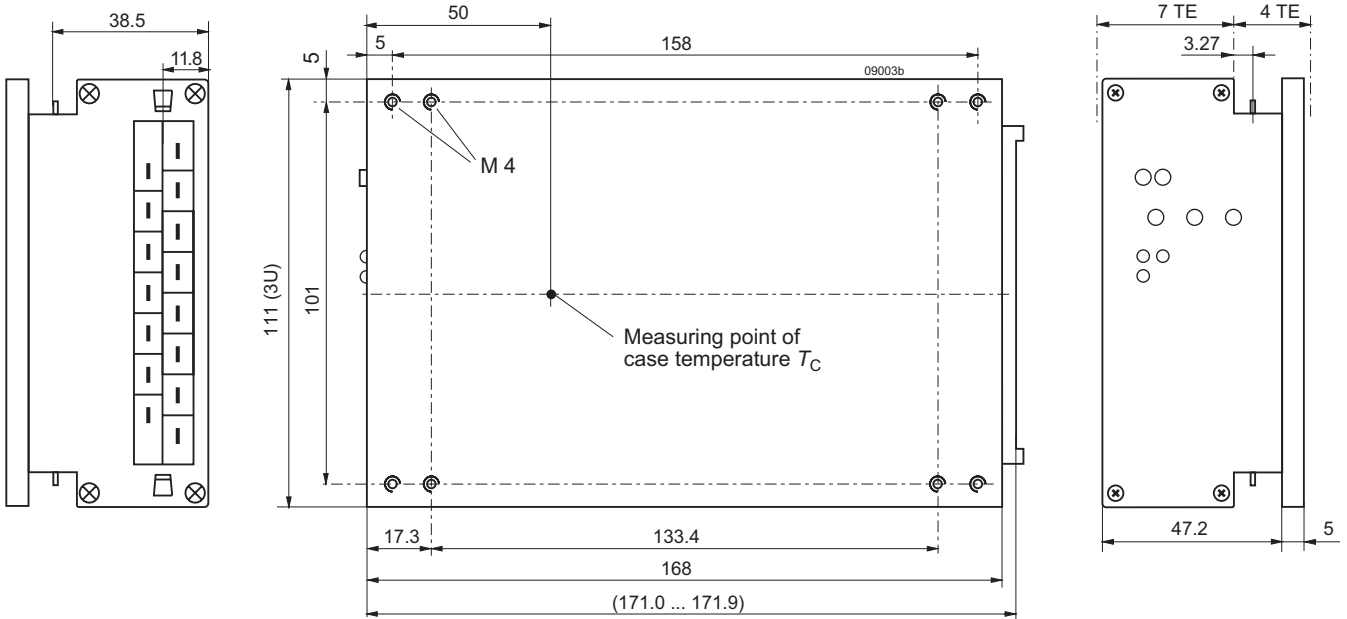
Dimensions in mm. The converters are designed to be inserted into a 19" rack, 160 mm long, according to IEC 60297-3.



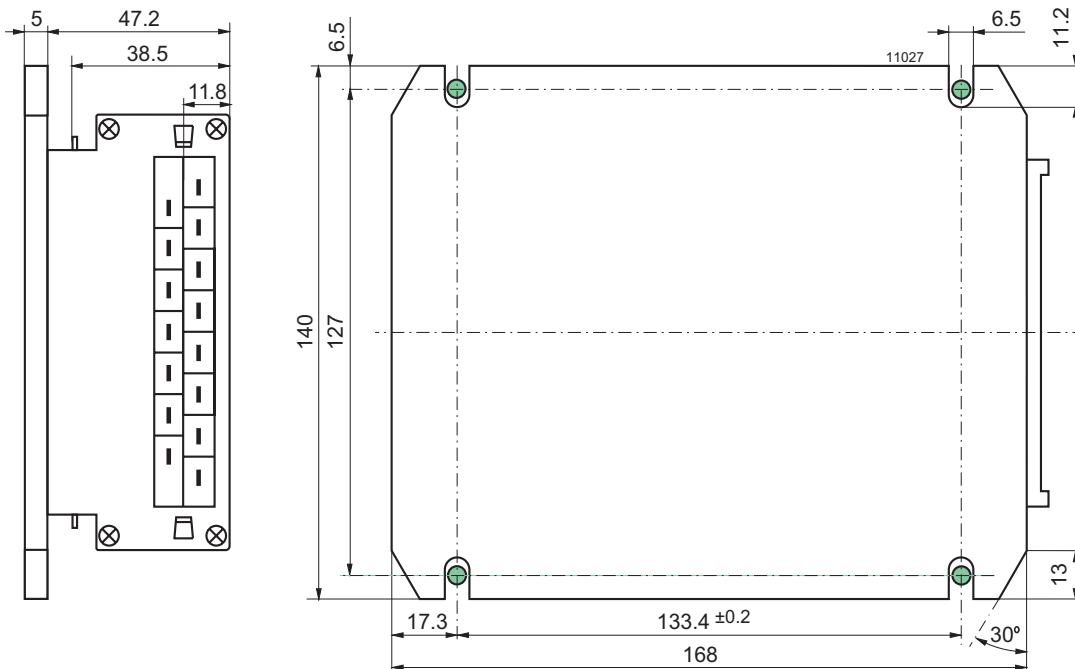
**Fig. 23**  
Aluminum case S02 with heat sink;  
black finish (EP powder coated);  
weight approx. 1.25 kg

**Notes:**

- $d \geq 15$  mm, recommended minimum distance to next part in order to ensure proper air circulation at full output power.
- free air location: the converter should be mounted with fins in a vertical position to achieve maximum airflow through the heat sink.



**Fig. 24**  
Option B1: Aluminum case S02 with small cooling plate; black finish (EP powder coated).  
Suitable for mounting with access from the backside.  
Total weight approx. 1.2 kg.



**Fig. 25**  
Option B: Aluminum case S02 with large cooling plate; black finish (EP powder coated).  
Suitable for front mounting.  
Total weight approx. 1.3 kg

**Note:** Long case with option B2, elongated by 60 mm for 220 mm rack depth, is available on request. (No LEDs, no test jacks.)

## Safety and Installation Instructions

### Connector Pin Allocation

The connector pin allocation table defines the electrical potentials and the physical pin positions on the H15 connector. The protective earth is connected by a leading pin (no. 24), ensuring that it makes contact with the female connector first.

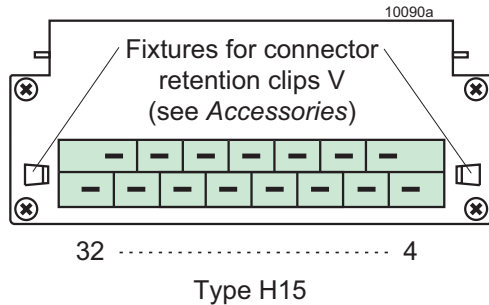


Fig. 26  
View of the connector (male contacts)

Table 13: H15 connector pin allocation

Pin No.	Connector type H15			
	single-output models		double-output models	
4	Vo+	Pos. output 1	Vo2+	Pos. output 2
6	Vo+		Vo2+	
8	Vo-	Neg. output 1	Vo2-	Neg. output 2
10	Vo-		Vo2-	
12	S+	Pos. sense	Vo1+	Pos. output 1
14	S-	Neg. sense	Vo1-	Neg. output 1
16	R <sup>1</sup>	Control of V <sub>o</sub>	R <sup>1</sup>	Control of V <sub>o1</sub>
18	i	Inhibit	i	Inhibit
20	D <sup>3</sup>	Save data	D <sup>3</sup>	Safe data
	V <sup>3</sup>	ACFAIL		
22	T <sup>5</sup>	Current sharing	T <sup>5</sup>	Current sharing
24 <sup>2</sup>	⊕	Protective earth	⊕	Protective earth
26	Vi+ N <sub>~</sub> <sup>4</sup>	Pos. input	Vi+ N <sub>~</sub> <sup>4</sup>	Pos. input
28		Neutral line <sup>4</sup>		Neutral line <sup>4</sup>
30	Vi- L <sub>~</sub> <sup>4</sup>	Neg. input	Vi- L <sub>~</sub> <sup>4</sup>	Neg. input
32		Phase line <sup>4</sup>		Phase line <sup>4</sup>

<sup>1</sup> Not connected, if option P is fitted.

<sup>2</sup> Leading pin (pre-connecting)

<sup>3</sup> Option D excludes option V and vice versa. Pin 20 is not connected, unless option D or V is fitted.

<sup>4</sup> LS models

<sup>5</sup> Only connected, if option T is fitted.

### Installation Instructions

**Note:** These converters have no power factor correction (PFC). The LS4000/5000 models are intended to replace the LS1000 and LS2000 converters in AC applications to comply with IEC/EN 61000-3-2.

The converters are components, intended exclusively for inclusion within other equipment by an industrial assembly operation or by professional installers. Installation must strictly follow the national safety regulations in compliance with the enclosure, mounting, creepage, clearance, casualty, markings, and segregation requirements of the end-use application.

Connection to the system shall be made via the female connector H15; see *Accessories*. Other installation methods may not meet the safety requirements.

Pin no. 24 (⊕) is connected with the case. For safety reasons it is essential to connect this pin reliably to protective earth.

The input pins 30/32 (Vi- or L<sub>~</sub>) are connected via a built-in fuse, which is designed to protect in the case of a converter failure. An additional external fuse, suitable for the application, might be necessary in the wiring to the other input 26/28 (Vi+ or N<sub>~</sub>) or even to pins 30/32, particularly if:

- Local requirements demand an individual fuse in each source line
- Phase and neutral of the AC mains are not defined or cannot be assigned to the corresponding terminals.
- Neutral and earth impedance is high or undefined.

#### Notes:

- If the inhibit function is not used, pin no. 18 (i) shall be connected with pin no. 14 to enable the output(s).
- Do not open the converter, or warranty will be invalidated.
- Due to high current values, the converters provide two internally parallel connected contacts for certain paths (pins 4/6, 8/10, 26/28 and 30/32). It is recommended to connect both female connector pins of each path in order to keep the voltage drop low and avoid excessive connector currents.
- If the second output of double-output models is not used, connect it parallel with the main output.

Make sure that there is sufficient airflow available for convection cooling and verify it by measuring the case temperature T<sub>C</sub>, when the converter is installed and operated in the end-use application; see *Thermal Considerations*.

Ensure that a converter failure (e.g., an internal short-circuit) does not result in a hazardous condition.

### Standards and Approvals

The converters are safety-approved according to the latest edition of IEC/EN 60950-1 and UL/CSA 60950-1.

The converters correspond to Class I equipment and have been evaluated for:

- Building-in
- Basic insulation between input and case based on 250 VAC, and double or reinforced insulation between input and output(s)



Table 14: Isolation

Characteristic		Input to case and output(s)	Output(s) to case	Output 1 to output 2	Unit
Electric strength test	Factory test >1 s	2.8 <sup>1</sup>	1.4	0.15	kVDC
	AC test voltage equivalent to factory test	2.0 <sup>1</sup>	1.0	0.1	kVAC
Insulation resistance at 500 VDC		>300	>300	>100 <sup>2</sup>	MΩ
Creepage distances		≥3.2 <sup>3</sup>	--	--	mm

<sup>1</sup> According to IEC/EN 60950, subassemblies connecting input to output are pre-tested with 5.6 kVDC or 4 kVAC.

<sup>2</sup> Tested at 150 VDC

<sup>3</sup> Input to outputs: 6.4 mm

- Functional insulation between outputs
- Overvoltage category II
- Pollution degree 2 environment
- Max. altitude: 2000 m
- The converters fulfill the requirements of a fire enclosure.

The converters are subject to manufacturing surveillance in accordance with the above mentioned standards and ISO 9001:2008. A CB-scheme is available.

### Railway Applications and Fire Protection

The converters have been designed by observing the railway standards EN 50155, EN 50121-3-2, and EN 50121-4. All boards are coated with a protective lacquer.

The converters with version V108 (or later) comply with NF-F16 (I2/F1). They also comply with EN 45545-1, EN 45545-2 (2013), if installed in a technical compartment or cabinet.

### Protection Degree and Cleaning Liquids

Condition: Female connector fitted to the converter.

- IP 30: All models except those with option P, and except those with option D or V including a potentiometer.
- IP 20: All models fitted with option P, or with option D or V with potentiometer.

In order to avoid damage, any penetration of cleaning fluids has to be prevented, since the power supplies are not hermetically sealed.

### Isolation and Protective Earth

The electric strength test is performed in the factory as routine test according to EN 50514 and IEC/EN 60950 and should not be repeated in the field. The company will not honor warranty claims resulting from incorrectly executed electric strength tests. The resistance of the earth connection to the case (<0.1 Ω) is tested as well.

### Leakage Currents

Leakage currents flow due to internal leakage capacitances and Y-capacitors. The current values are proportional to the supply voltage and are specified in the table below.

Table 15: Earth leakage currents for LS models

Characteristic		Class I	Unit
Max. leakage current	Permissible accord. to IEC/EN 60950	3.5	mA
	Typ. value at 264 V, 50 Hz	1.43	

### LS Models Operated at Greater than 63 Hz

Above 63 Hz, the earth leakage current may exceed 3.5 mA, the maximum value allowed in IEC 60950. Frequencies ≥ 350 Hz are only permitted with  $V_i \leq 200$  VAC.

The built-in Y-caps are approved for ≤100 Hz. Safety approvals and CB scheme cover only 50 – 60 Hz.

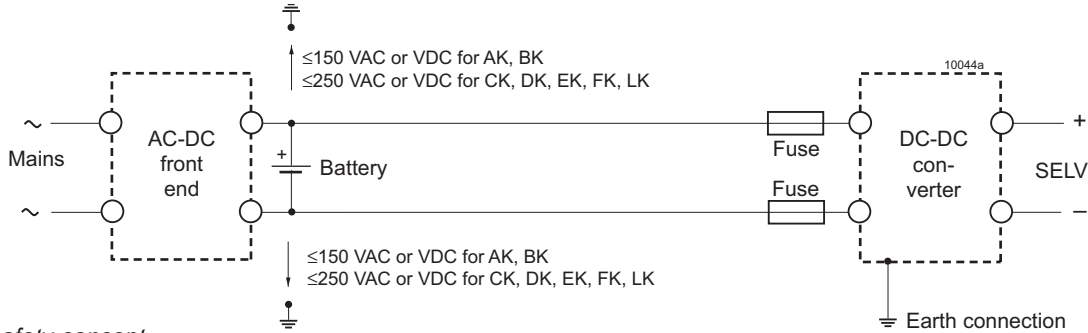
### Safety of Operator-Accessible Output Circuits

If the output circuit of a **DC-DC converter** is operator-accessible, it shall be an SELV circuit according to the standard IEC 60950-1.

The following table shows some possible installation configurations, compliance with which causes the output

circuit of the converter to be an SELV circuit according to IEC 60950-1 up to a configured output voltage (sum of nominal voltages if in series or +/- configuration) of 36 V.

However, it is the sole responsibility of the installer to assure the compliance with the applicable safety regulations.



**Fig. 27**  
 Schematic safety concept.  
 Use earth connections as per the table below.

**Table 16: Safety concept leading to an SELV output circuit**

Conditions	Front end		DC-DC converter		Result	
	Minimum required grade of insulation, to be provided by the AC-DC front end, including mains supplied battery charger	Nominal DC output voltage from the front end	Minimum required safety status of the front end output circuit	Types		Measures to achieve the specified safety status of the output circuit
Mains ≤150 V AC	Functional (i.e. there is no need for electrical insulation between the mains supply voltage and the DC-DC converter input voltage)	≤100 V (The nominal voltage between any input pin and earth can be up to 150 V AC or DC)	Primary circuit	AS BS	Double or reinforced insulation, based on the mains voltage and <sup>2</sup> (provided by the DC-DC converter) and earthed case <sup>3</sup>	SELV circuit
Mains ≤250 V AC		≤400 V (The nominal voltage between any input pin and earth can be up to 250 V AC or 400 V DC)		CS DS ES FS		
Basic	≤400 V	Unearthed hazardous voltage secondary circuit	AS BS CS DS ES FS	Supplementary insulation, based on 250 V AC and double or reinforced insulation <sup>2</sup> (provided by DC-DC converter) and earthed case <sup>3</sup> .		
		Earthed hazardous voltage secondary circuit		Double or reinforced insulation <sup>2</sup> (provided by the DC-DC converter) earthed case <sup>3</sup>		
Double or reinforced	≤60 V	SELV circuit	AS BS CS DS ES FS	Functional insulation (provided by the DC-DC converter) <sup>4</sup>		
		≤120 V		TNV-3 circuit	Basic insulation (provided by the DC-DC converter) <sup>4</sup>	

<sup>1</sup> The front end output voltage should match the specified input voltage range of the DC-DC converter.  
<sup>2</sup> Based on the maximum nominal output voltage from the front end.  
<sup>3</sup> The earth connection has to be provided by the installer according to the relevant safety standard, e.g. IEC/EN 60950-1.  
<sup>4</sup> Earthing of the case is recommended, but not mandatory.

If the output circuit of an **AC-DC converter** is operator-accessible, it shall be an SELV circuit accord. to IEC 60950-1.

The following table shows some possible installation configurations, compliance with which causes the output circuit of **LS models** to be SELV according to IEC 60950-1 up to a configured output voltage (sum of nominal voltages if in series or +/- configuration) of 36 V.

If the LS converter is used as DC-DC converter, refer to the previous section.

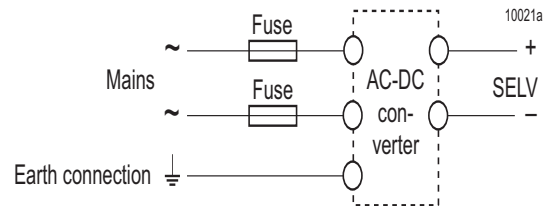


Fig. 28

Schematic safety concept. Use earth connection as per table 17. Use fuses if required by the application; see also Installation Instructions.

Table 17: Safety concept leading to an SELV output circuit

Conditions	AC-DC converter	Installation	Result
Nominal voltage	Grade of insulation between input and output provided by the AC-DC converter	Measures to achieve the resulting safety status of the output circuit	Safety status of the AC-DC converter output circuit
Mains ≤250 VAC	Double or reinforced	Earthed case <sup>1</sup> and installation according to the applicable standards	SELV circuit

<sup>1</sup> The earth connection has to be provided by the installer according to the relevant safety standards, e.g. IEC/EN 60950.

## Description of Options

Table 18: Survey of options

Option	Function of option	Characteristic
-7	Extended operational ambient temperature range	$T_A = -25$ to $71$ °C
E	Electronic inrush current limitation circuitry	Active inrush current limitation
P <sup>2</sup>	Potentiometer for fine adjustment of output voltage	Adjustment range $+10/-60\%$ of $V_{o\ nom.}$ , excludes R input
D <sup>1</sup>	Input and/or output undervoltage monitoring circuitry	Safe data signal output (D0 – DD)
V <sup>1</sup>	Input and/or output undervoltage monitoring circuitry	ACFAIL signal according to VME specifications (V0, V2, V3)
T	Current sharing	Interconnect T-pins for parallel connection (max 5 converters)
B, B1, B2	Cooling plate (160 or 220 mm long)	Replaces the standard heat sink, allowing direct chassis-mounting
non-G	RoHS-compliant for 5 substances	Tin-lead solder

<sup>1</sup> Option D excludes option V and vice versa; option V only for 5.1 V outputs.

<sup>2</sup> Option P is not available for battery charger models.

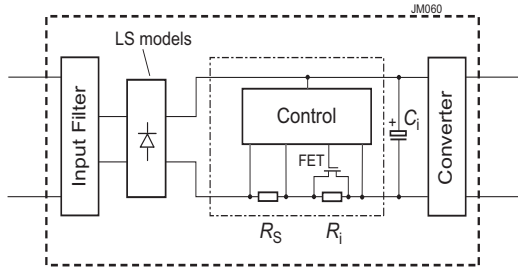
### -7 Temperature Range

Option -7 designates converters with an operational ambient temperature range of  $-25$  to  $71$  °C. Not for new designs.

### E Inrush Current Limitation

CS/DS/ES/FS/LS models may be supplemented by an electronic circuit (option E) replacing the standard built-in NTC

resistor) in order to achieve an enhanced inrush current limiting function. Option E is not available with AS/BS models, but mandatory for all CS/DS/ES/FS/LS models with option -9.



**Fig. 29**  
 Block diagram of option E  
 Current limiting resistance  $R_V = R_S + R_I = 15 \Omega$

The figure below shows two consecutive peaks of the inrush current, the first one is caused by  $V_i/R_V$  and the second one by the rising current across the FET. The shape of the curve depends on model, but the tables below show the higher of both peaks.

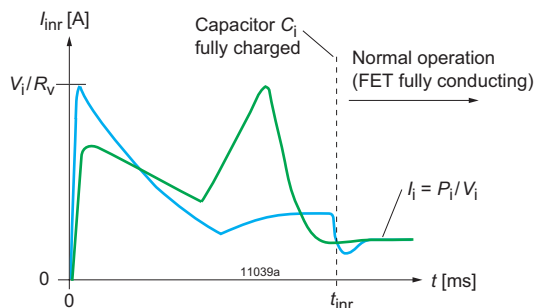
CS models fitted with option E and option D6 (input voltage

**Table 19a: Inrush current at  $V_{i, nom}$  (DC supply) and  $I_{o, nom}$**

Characteristics		FS	CS	DS	ES	LS	Unit
$V_{i, nom}$	Input voltage	50	60	110	220	310	V
$I_{inr, p}$	Peak inrush current	7.5	6.5	7.4	14.6	21	A
$t_{inr}$	Inrush current duration	20	25	14	16	16	ms

**Table 19b: Inrush current at  $V_{i, max}$  (DC supply) and  $I_{o, nom}$**

Characteristics		FS	CS	DS	ES	LS	Unit
$V_{i, nom}$	Input voltage	100	140	220	385	372	V
$I_{inr, p}$	Peak inrush current	10	9	14.5	25.7	24.8	A
$t_{inr}$	Inrush current duration	26	30	14	12	16	ms



**Fig. 30**  
 Inrush current with option E (DC supply)  
 2 different wave shapes depending on model

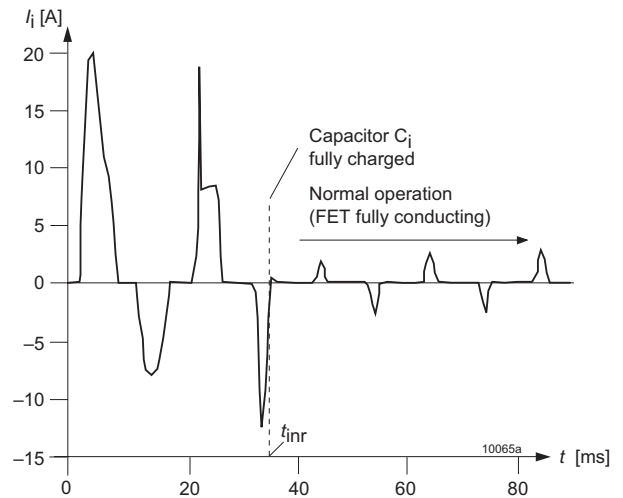
monitor) meet the standard ETS 300132-2 for 48 VDC supplies. Option D6 is necessary to disable the converter at low input voltage, such as avoiding an excessive input current. Connect output D (pin 20) with inhibit (pin 18).

Option D6 should be adjusted with the potentiometer to a threshold of 36 – 40.5 V for 48 V batteries and to 44 – 50 V for 60 V batteries. Refer also to the description of option D.

**Note:** Subsequent switch-on cycles at start-up are limited to max. 10 cycles during the first 20 seconds (cold converter) and then to max. 1 cycle every 8 s.

LS models powered by 230 VAC /50 Hz exhibit an inrush current as per the fig. below, when switched on at the peak of  $V_i$ . In this case, the inrush current  $I_{inr, p}$  is 21.7 A and its duration  $t_{inr}$  is 5 ms. This is the worst case.

If the LS converter is switched on in a different moment,  $I_{inr, p}$  is much lower, but  $t_{inr}$  rises up to 10 ms.



**Fig. 31**  
 Inrush current for LS models with option E (AC supply)  
 $V_i = 230 \text{ VAC}$ ,  $f_i = 50 \text{ Hz}$ ,  $P_o = P_{o, nom}$

### P Potentiometer

A potentiometer provides an output voltage adjustment range of +10/–60% of  $V_{o, nom}$ . It is accessible through a hole in the front cover. Option P is not available for battery charger models and is not recommended for converters connected in parallel.

Option P excludes the R-function. With double-output models, both outputs are influenced by the potentiometer (doubling the voltage, if the outputs are connected in series).

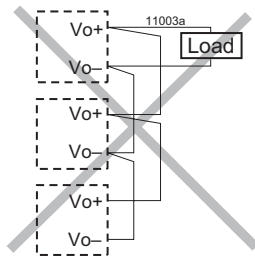
**Note:** If the output voltages are increased above  $V_{o, nom}$  via R input control, option P setting, remote sensing, or option T, the output

### T Current Sharing

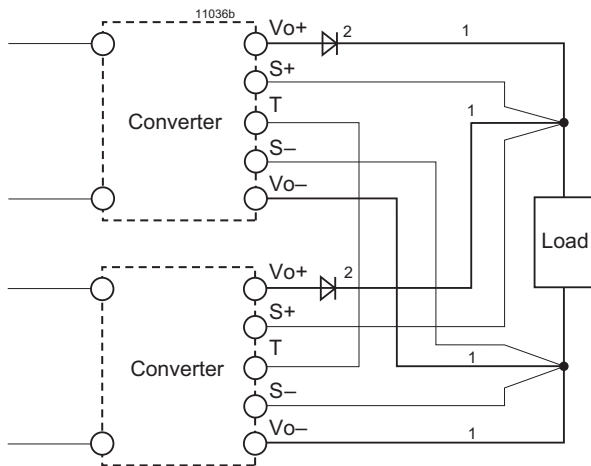
This option ensures that the output currents are approximately shared between the parallel-connected converters, hence increasing system reliability. To use this facility, simply interconnect the T pins of all converters and make sure that the reference for the T signal, pin 14 (S- or Vo1-), are also connected together. The load lines should have equal length and cross section to ensure equal voltage drops.

Not more than 5 converters should be connected in parallel. The R pins should be left open-circuit. If not, the output voltages must be individually adjusted prior to paralleling within 1 to 2% or the R pins should be connected together.

**Note:** Parallel connection of converters with option P is not recommended.

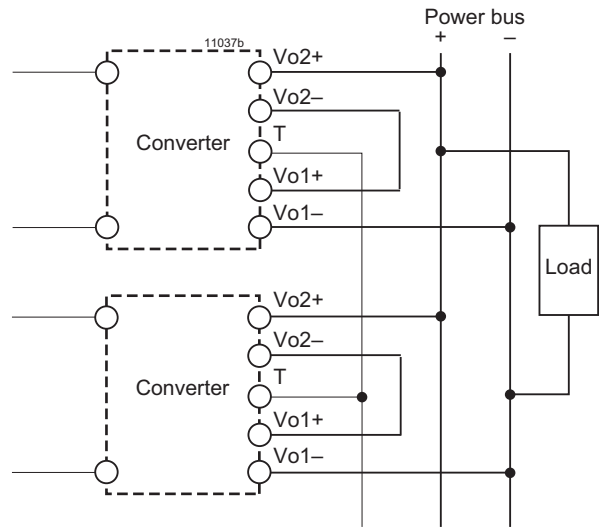


**Fig. 32**  
 Example of poor wiring for parallel connection (unequal length of load lines)



- Max. 5 converters in parallel connection
- 1 Lead lines should have equal length and cross section, and should run in the same cable loom.
  - 2 Diodes recommended in redundant operation only

**Fig. 33**  
 Parallel connection of single-output models using option T with the sense lines connected at the load



Max. 5 converters in parallel connection

**Fig. 34**  
 Parallel connection of double-output models with the outputs connected in series, using option T. The signal at the T pins is referenced to Vo1-.

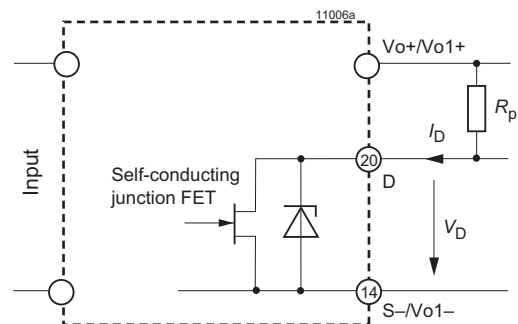
### D Undervoltage Monitor

The input and/or output undervoltage monitor operates independently of the built-in input undervoltage lockout circuit. A logic "low" signal (output with self-conducting JFET) or "high" signal (NPN open-collector output) is generated at the D output (pin 20), when one of the monitored voltages drops below the preselected threshold level  $V_t$ . This signal is referenced to S- / Vo1-. The D output recovers, when the monitored voltages exceed  $V_t + V_h$ . The threshold levels  $V_{ti}$  and  $V_{to}$  are either adjusted by a potentiometer, accessible through a hole in the front cover, or adjusted in the factory to a fixed value specified by the customer.

Option D exists in various versions D0 – D4, as shown in table 20.

#### JFET output (D0 – D4):

Pin D is internally connected via the drain-source path of a JFET (self-conducting type) to the negative potential of output 1.  $V_D \leq 0.4$  V (logic low) corresponds to a monitored voltage



**Fig. 35**  
 Option D0 – D4: JFET output,  $I_D \leq 2.5$  mA

Table 20: Undervoltage monitoring functions

Output type		Monitoring		Minimum adjustment range of threshold level $V_t$ for $V_{t\min}$ – $V_{t\max}$		Typ. hysteresis $V_{ho}$ [% of $V_i$ ] potentiometer		Number of meters
JFET	NPN	$V_i$	$V_o$ or $V_{o1}$	$V_{ti}$	$V_{to}$	$V_{hi}$	$V_{ho}$	
D1	D5	no	yes	--	$3.5 V - V_{oBR}^1$	--	$2.5 - 0.6 V$	1
D2	D6	yes	no	$V_{i\min} - V_{i\max}^1$	--	$3.4 - 0.4 V$	--	1
D3	D7	yes	yes	$V_{i\min} - V_{i\max}^1$	$(0.95 - 0.985 V_o)^2$	$3.4 - 0.4 V$	"0"	1
D4	D8	no	yes	--	$(0.95 - 0.985 V_o)^2$	--	"0"	--
D0 <sup>5</sup>	D9 <sup>5</sup>	no	yes	--	$3.5 V - V_{oBR} V^3$	--	$2.5 - 0.6 V$	--
		yes	no	$V_{i\min} - V_{i\max}^{3,4}$	--	$3.4 - 0.4 V$	--	
		yes	yes	$V_{i\min} - V_{i\max}^{3,4}$	$3.5 V - V_{oBR} V^{3,4}$	$3.4 - 0.4 V$	$2.5 - 0.6 V$	
		yes	yes	$V_{i\min} - V_{i\max}^{3,4}$	$(0.95 - 0.985 V_o)^2$	$3.4 - 0.4 V$	"0"	
--	DD	yes	yes	$V_{i\min} - V_{i\max}^1$	$3.5 V - V_{oBR} V^1$	$3.4 - 0.4 V$	$2.5 - 0.6 V$	2

- <sup>1</sup> Threshold level adjustable by potentiometer; see Electrical Output Data for  $V_{oBR}$ .
- <sup>2</sup> Fixed value. Tracking if  $V_o/V_{o1}$  is adjusted via R-input, option P, or sense lines.
- <sup>3</sup> The threshold level permanently adjusted according to customer specification  $\pm 2\%$  at 25 °C. Any value within the specified range is basically possible, but causes a special type designation in addition to the standard option designations (D0/D9). See Electrical Output Data for  $V_{oBR}$ .
- <sup>4</sup> Adjustment at  $I_o\text{ nom}$ .
- <sup>5</sup> Customer-specific part number

Table 21: JFET output (D0 -- D4)

$V_b, V_{o1}$ status	D output, $V_D$
$V_b$ or $V_{o1} < V_t$	low, L, $V_D \leq 0.4 V$ at $I_D = 2.5 mA$
$V_b$ and $V_{o1} > V_t + V_h$	high, H, $I_D \leq 25 \mu A$ at $V_D = 5.25 V$

level ( $V_i$  and/or  $V_{o1}$ )  $< V_t$ . The current  $I_D$  through the JFET should not exceed 2.5 mA. The JFET is protected by a 0.5 W Zener diode of 8.2 V against external overvoltages.

#### NPN output (D5 – DD):

Pin D is internally connected via the collector-emitter path of a NPN transistor to the negative potential of output 1.  $V_D < 0.4 V$

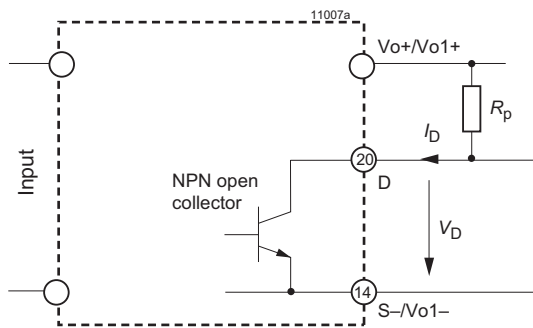


Fig. 36  
 Option D5 – DD: NPN output,  $V_o \leq 40, I_D \leq 2.5 mA$

Table 22: NPN output (D5 – DD)

$V_b, V_{o1}$ status	D output, $V_D$
$V_b$ or $V_{o1} < V_t$	high, H, $I_D \leq 25 \mu A$ at $V_D = 40 V$
$V_b$ and $V_{o1} > V_t + V_h$	low, L, $V_D \leq 0.4 V$ at $I_D = 20 mA$

(logic low) corresponds to a monitored voltage level ( $V_i$  and/or  $V_{o1}$ )  $> V_t + V_h$ . The current  $I_D$  through the open collector should not exceed 20 mA. The NPN output is not protected against external overvoltages.  $V_D$  should not exceed 40 V.

#### Threshold tolerances and hysteresis:

If  $V_i$  is monitored, the internal input voltage after the input filter is measured. Consequently this voltage differs from the voltage at the connector pins by the voltage drop  $\Delta V_{ti}$  across the input filter. The threshold levels of the D0 and D9 options are factory adjusted at nominal output current  $I_o\text{ nom}$  and  $T_A = 25$  °C. The value of  $\Delta V_{ti}$  depends upon input voltage range (CK, DK, ..), threshold level  $V_t$ , temperature, and input current. The input current is a function of the input voltage and the output power.

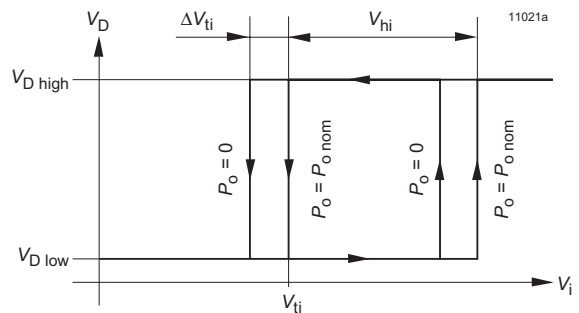
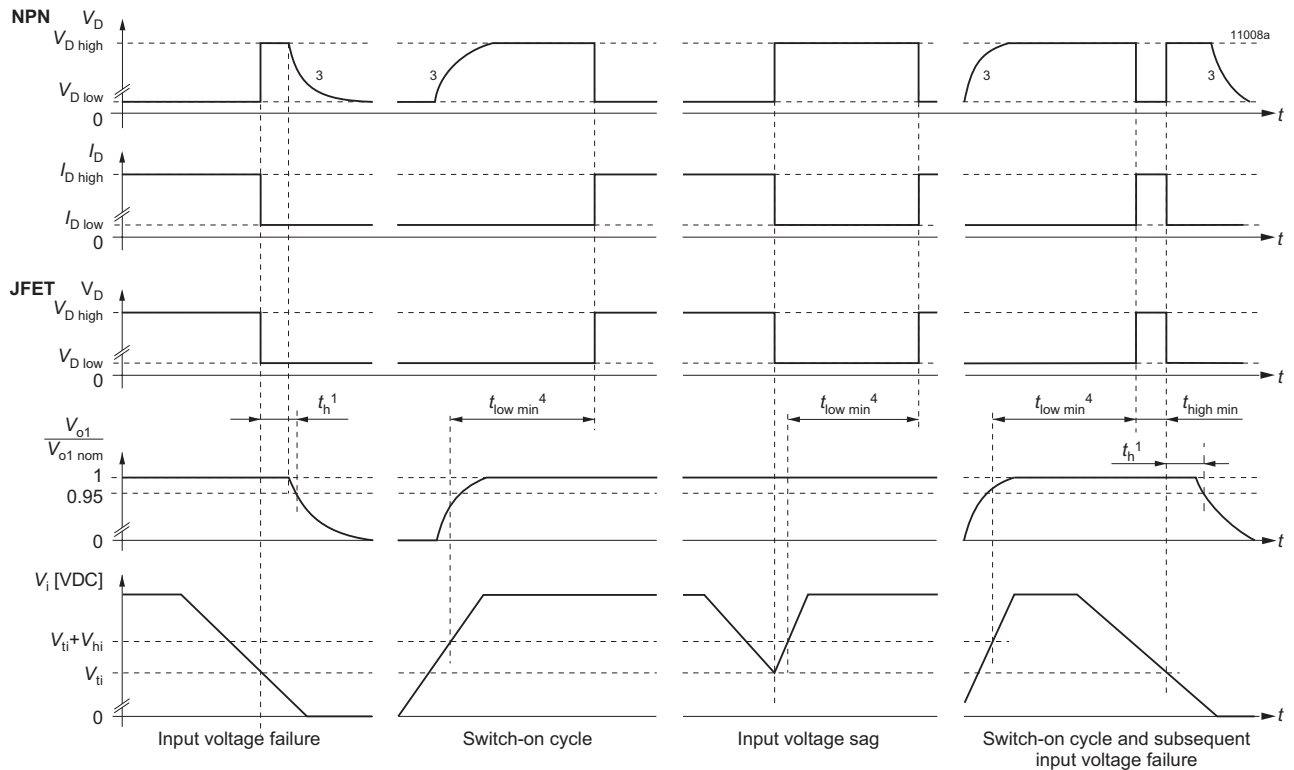


Fig. 37  
 Definition of  $V_{ti}$ ,  $\Delta V_{ti}$  and  $\Delta V_{hi}$  (JFET output)



Table 23: D-output logic signals

Version of D	$V_i < V_t$ or $V_o < V_t$	$V_i > V_t + V_h$ or $V_o > V_t$	Configuration
D1, D2, D3, D4, D0	low	high	JFET
D5, D6, D7, D8, D9, DD	high	low	NPN

**Input voltage monitoring**

**Output voltage monitoring**


- 1 Hold-up time see *Electrical Input Data*
- 2 With output voltage monitoring, hold-up time  $t_h = 0$
- 3 The signal remains high, if the D output is connected to an external source
- 4  $t_{low\ min} = 100 - 170$  ms, typ. 130 ms

 Fig. 38  
 Relationship between  $V_i$ ,  $V_o$ ,  $V_D$ ,  $V_o/V_o\ nom$  versus time

**Table 24: Option V: Factory potentiometer setting of  $V_{ti}$  with resulting hold-up time**

Model	AS	BS	FS	CS	DS	ES	LS	Unit
$V_{ti}$	9.5	19.5	39	39	61	97	120	VDC
$t_h$	0.1	0.1	3.4	1.1	1.1	2.7	4.2	ms

### V ACFAIL signal (VME)

Available for converters with  $V_{o,nom} = 5.1$  V only.

This option defines an undervoltage monitoring circuit for the input or for the input and main output voltage (5.1 V) similar to option D and generates an ACFAIL signal (V signal), which conforms to the VME standard.

The low state level of the ACFAIL signal is specified at a sink current of  $I_V \leq 48$  mA to  $V_V \leq 0.6$  V (open-collector output of an NPN transistor). The pull-up resistor feeding the open-collector output should be placed on the VME back plane.

After the ACFAIL signal has gone low, the VME standard requires a hold-up time  $t_h$  of at least 4 ms, before the 5.1 V output drops to 4.875 V, when the output is fully loaded. This hold-up time  $t_h$  is provided by the internal input capacitance  $C_{i}$ ; see tab. *Input Data*. Consequently the working input voltage and the threshold level  $V_{ti}$  should be adequately above  $V_{i,min}$  of the converter, so that enough energy is remaining in the input capacitance. If  $V_i$  is below the required level, an external hold-up capacitor ( $C_{i,ext}$ ) should be added; refer to these formulas:

$$V_{ti} = \sqrt{\frac{2 \cdot P_o \cdot (t_h + 0.3 \text{ ms}) \cdot 100}{C_{i,min} \cdot \eta}} + V_{i,min}^2$$

$$C_{i,ext} = \frac{2 \cdot P_o \cdot (t_h + 0.3 \text{ ms}) \cdot 100}{\eta \cdot (V_{ti}^2 - V_{i,min}^2)} - C_{i,min}$$

where as:

$C_{i,min}$  = internal input capacitance [mF]; see table 2

$C_{i,ext}$  = external input capacitance [mF]

$P_o$  = output power [W]

$\eta$  = efficiency [%]

$t_h$  = hold-up time [ms]

$V_{i,min}$  = minimum input voltage [V]<sup>1</sup>

$V_{ti}$  = threshold level [V]

<sup>1</sup>  $V_{i,min}$  see *Electrical Input Data*. For output voltages  $V_o > V_{o,nom}$ ,  $V_{i,min}$  increases proportionally to  $V_o/V_{o,nom}$ .

**Note:** Option V2 and V3 can be adjusted by the potentiometer to a threshold level between  $V_{i,min}$  and  $V_{i,max}$ . A decoupling diode should be connected in series with the input of AS – FS converters to avoid the input capacitance being discharged through other loads connected to the same source voltage.

Option V operates independently of the built-in input undervoltage lockout circuit. A logic "low" signal is generated at pin 20, as soon as one of the monitored voltages drops below the preselected threshold level  $V_t$ . The return for this signal is S–. The V output recovers, when the monitored voltages exceed  $V_t + V_h$ . The threshold level  $V_{ti}$  is either adjustable by a potentiometer, accessible through a hole in the front cover, or adjusted in the factory to a determined customer-specific value. Refer to table 25.

### V output (V0, V2, V3):

Pin V is internally connected to the open collector of an NPN transistor. The emitter is connected to S–.  $V_V \leq 0.6$  V (logic low) corresponds to a monitored voltage level ( $V_i$  and/or  $V_o$ )  $< V_t$ .  $I_V$  should not exceed 50 mA. The V output is not protected against external overvoltages:  $V_V$  should not exceed 60 V.

Threshold tolerances and hysteresis:

If  $V_i$  is monitored, the internal input voltage is measured after the input filter. Consequently this voltage differs from the

**Table 26: NPN-output (V0, V2, V3)**

$V_i, V_o$ status	V output, $V_V$
$V_i$ or $V_{o1} < V_t$	low, L, $V_V \leq 0.6$ V at $I_V = 50$ mA
$V_i$ and $V_{o1} > V_t + V_h$	high, H, $I_V \leq 25$ $\mu$ A at $V_V = 5.1$ V

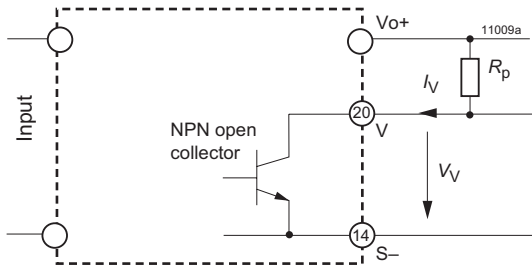
voltage at the connector pins by the voltage drop  $\Delta V_{ti}$  across the input filter. The threshold level of option V0 is adjusted in the factory at  $I_{o,nom}$  and  $T_A = 25$  °C. The value of  $\Delta V_{ti}$  depends upon the input voltage range (AK, BK, etc.), threshold level  $V_t$ , temperature, and input current. The input current is a function of input voltage and output power.

**Table 25: Undervoltage monitor functions**

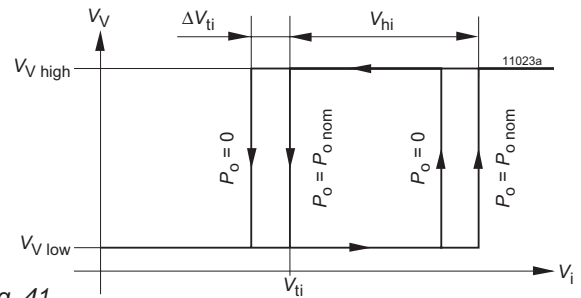
Option	Monitoring		Minimum adjustment range of threshold level $V_t$		Typical hysteresis $V_h$ [% of $V_i$ ] for $V_{t,min} - V_{t,max}$	
	$V_i$	$V_{o1}$	$V_{ti}$	$V_{to}$	$V_{hi}$	$V_{ho}$
V2	yes	no	$V_{i,min} - V_{i,max}$ <sup>1</sup>	--	3.4 - 0.4	--
V3	yes	yes	$V_{i,min} - V_{i,max}$ <sup>1</sup>	$0.95 - 0.985 V_{o1}$ <sup>2</sup>	3.4 - 0.4	"0"
V0	yes	no	$V_{i,min} - V_{i,max}$ <sup>3,4</sup>	--	3.4 - 0.4	--
	yes	yes	$V_{i,min} - V_{i,max}$ <sup>3,4</sup>	$0.95 - 0.985 V_{o1}$ <sup>2</sup>	3.4 - 0.4	"0"

<sup>1</sup> Threshold level adjustable by potentiometer. <sup>2</sup> Fixed value between 95% and 98.5% of  $V_{o1}$  (tracking). <sup>3</sup> Adjusted at  $I_{o,nom}$ .

<sup>4</sup> Fixed value, resistor-adjusted ( $\pm 2\%$  at 25°C) accord. to customer's specification; individual type number is determined by the company..

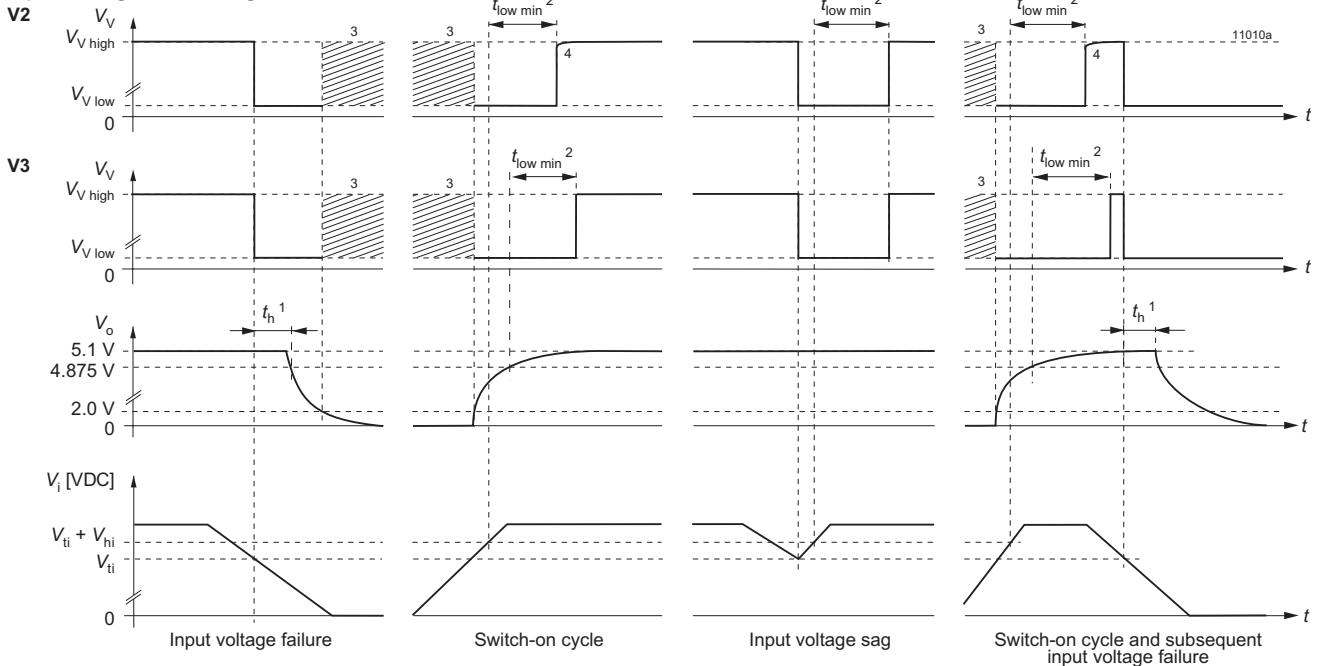


**Fig. 40**  
Output configuration of options V0, V2 and V3

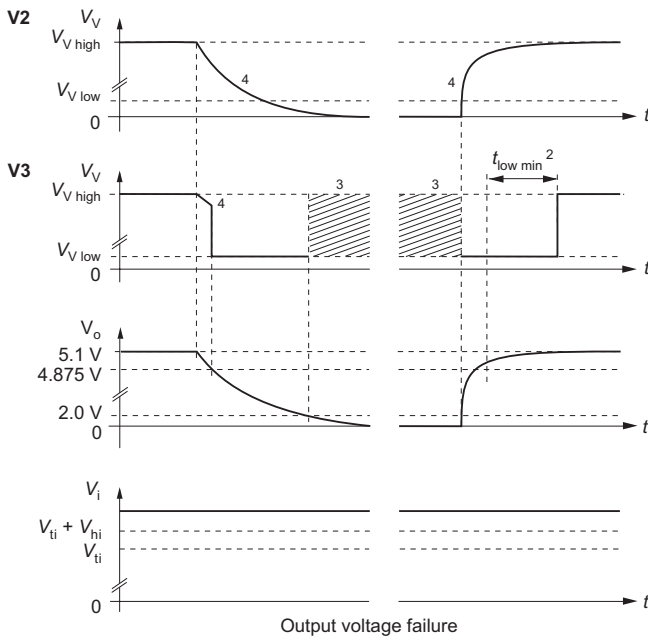


**Fig. 41**  
Definition of  $V_{ti}$ ,  $\Delta V_{ti}$  and  $V_{hi}$

**Input voltage monitoring**



**Output voltage monitoring**



- 1 VME request: minimum 4 ms
- 2  $t_{low\ min} = 40 - 200\ ms$ , typ 80 ms
- 3  $V_V$  level not defined at  $V_o < 2.0\ V$
- 4 The V signal drops simultaneously with  $V_o$ , if the pull-up resistor  $R_p$  is connected to  $V_{o+}$ ; the V signal remains high if  $R_p$  is connected to an external source.

**Fig. 39**  
Relationship between  $V_b$ ,  $V_o$ ,  $V_D$ ,  $V_o/V_{o\ nom}$  versus time

### B, B1, B2 Cooling Plate

Where a cooling surface is available, we recommend the use of a cooling plate instead of the standard heat sink. The mounting system should ensure that the maximum case temperature  $T_{C\ max}$  is not exceeded. The cooling capacity is calculated by ( $\eta$  see *Model Selection*):

$$P_{Loss} = \frac{(100\% - \eta)}{\eta} \cdot V_o \cdot I_o$$

For the dimensions of the cooling plates, see *Mechanical*

*Data.* Option B2 is for customer-specific models with elongated case (for 220 mm DIN-rack depth).

### G RoHS

RoHS-compliant for all six substances.

### Accessories

A variety of electrical and mechanical accessories are available including:

- Front panels for 19" DIN-rack: Schroff or Intermas, 12 TE /3U; see fig. 40.
- Mating H15 connectors with screw, solder, faston, or press-fit terminals, code key system and coding wedges HZZ00202-G; see fig. 41.
- Pair of connector retention clips HZZ01209-G; see fig. 42
- Connector retention brackets HZZ01216-G; see fig. 43
- Cage clamp adapter HZZ00144-G; see fig. 44



Fig. 40  
Different front panels

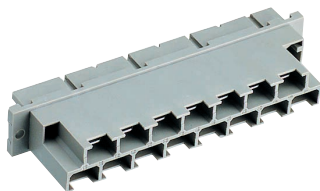


Fig. 41  
Different mating connectors

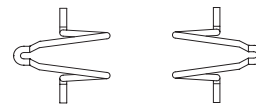


Fig. 42  
Connector retention clips to fasten the H15 connector to the rear plate; see fig. 24. HZZ01209-G consists of 2 clips.

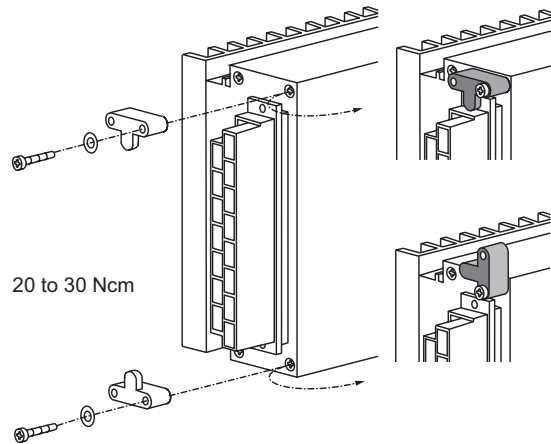


Fig. 43  
Connector retention brackets HZZ01216-G (CRB-HKMS)

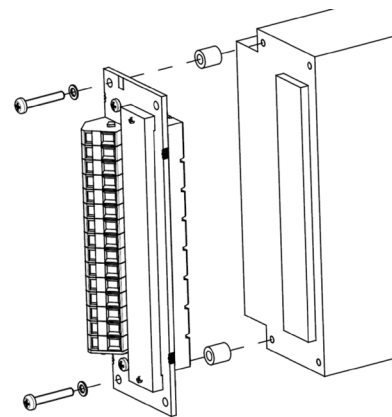


Fig. 44  
Cage clamp adapter HZZ00144-G

- Different cable hoods for H15 connectors (fig. 45):
  - HZZ00141-G, screw version
  - HZZ00142-G, use with retention brackets HZZ01218-G
  - HZZ00143-G, metallic version providing fire protection
- Chassis or wall-mounting plate K02 (HZZ01213-G) for models with option B1. Mating connector (HZZ00107-G) with screw terminals; see fig. 46
- DIN-rail mounting assembly HZZ0615-G (DMB-K/S); see fig. 47
- Additional external input and output filters
- Different battery sensors S-KSMH... for using the converter as a battery charger. Different cell characteristics can be selected; see fig. 48, table 27, and *Battery Charging/ Temperature Sensors*.

For additional accessory product information, see the accessory data sheets listed with each product series or individual model at our web site.

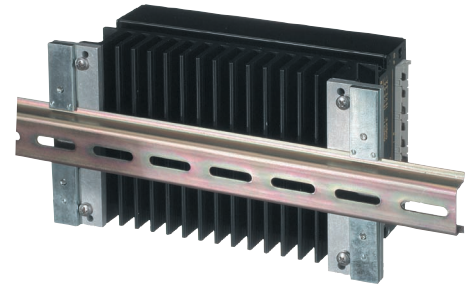


Fig. 47  
DIN-rail mounting assembly HZZ0615-G (DMB-K/S)

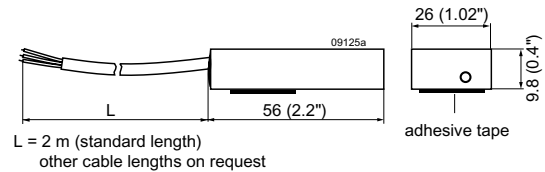


Fig. 48  
Battery temperature sensor



Fig. 45  
Different cable hoods



Fig. 46  
Chassis- or wall-mounting plate  
HZZ01213-G (Mounting plate K02)

Table 27: Battery temperature sensors

Battery voltage nom.[V]	Sensor type	Cell voltage [V]	Cell temp. coefficient [mV/K]	Cable length [m]
12	S-KSMH12-2.27-30-2	2.27	-3.0	2
12	S-KSMH12-2.27-35-2	2.27	-3.5	2
24	S-KSMH24-2.27-30-2	2.27	-3.0	2
24	S-KSMH24-2.27-35-2	2.27	-3.5	2
24	S-KSMH24-2.31-35-0	2.31	-3.5	4.5
24	S-KSMH24-2.31-35-2	2.31	-3.5	2
24	S-KSMH24-2.35-35-2	2.35	-3.5	2
48	S-KSMH48-2.27-30-2	2.27	-3.0	2
48	S-KSMH48-2-27-35-2	2.27	-3.5	2

**Note:** Other temperature coefficients and cable lengths are available on request.

NUCLEAR AND MEDICAL APPLICATIONS - These products are not designed or intended for use as critical components in life support systems, equipment used in hazardous environments, or nuclear control systems.

TECHNICAL REVISIONS - The appearance of products, including safety agency certifications pictured on labels, may change depending on the date manufactured. Specifications are subject to change without notice.

Copyright © 2017, Bel Power Solutions Inc. All rights reserved.

[www.belpowersolutions.com](http://www.belpowersolutions.com)

# Mouser Electronics

Authorized Distributor

Click to View Pricing, Inventory, Delivery & Lifecycle Information:

## Bel Power Solutions:

[LS1601-7R](#) [AS1601-7R](#) [BS2540-7RD6](#) [BS2660-9RG](#) [AS1601-9R](#) [AS1001-9RT](#) [BS1601-9RG](#) [AS1301-9RB1G](#)  
[CS1501-9ER](#) [CS2660-9ER](#) [ES1601-9ER](#) [ES2320-9ER](#) [LS1301-9ER](#) [FS1301-9ERB1](#) [LS2540-9ERB1](#) [DS1601-9ERBG](#) [LS1501-9ER](#) [LS1601-9ER](#) [LS4601-9ER](#) [CS1301-7R](#) [FS2540-7R](#) [LS5660-7R](#) [DS1501-9ERBG](#) [DS1001-9ERG](#) [DS1301-9ERTG](#) [DS2540-9ERBG](#) [DS2660-9ERG](#) [ES2660-9ERG](#) [LS2320-9ERG](#) [LS1001-9ERG](#)





Компания «ЭлектроПласт» предлагает заключение долгосрочных отношений при поставках импортных электронных компонентов на взаимовыгодных условиях!

Наши преимущества:

- Оперативные поставки широкого спектра электронных компонентов отечественного и импортного производства напрямую от производителей и с крупнейших мировых складов;
- Поставка более 17-ти миллионов наименований электронных компонентов;
- Поставка сложных, дефицитных, либо снятых с производства позиций;
- Оперативные сроки поставки под заказ (от 5 рабочих дней);
- Экспресс доставка в любую точку России;
- Техническая поддержка проекта, помощь в подборе аналогов, поставка прототипов;
- Система менеджмента качества сертифицирована по Международному стандарту ISO 9001;
- Лицензия ФСБ на осуществление работ с использованием сведений, составляющих государственную тайну;
- Поставка специализированных компонентов (Xilinx, Altera, Analog Devices, Intersil, Interpoint, Microsemi, Aeroflex, Peregrine, Syfer, Eurofarad, Texas Instrument, Miteq, Cobham, E2V, MA-COM, Hittite, Mini-Circuits, General Dynamics и др.);

Помимо этого, одним из направлений компании «ЭлектроПласт» является направление «Источники питания». Мы предлагаем Вам помощь Конструкторского отдела:

- Подбор оптимального решения, техническое обоснование при выборе компонента;
- Подбор аналогов;
- Консультации по применению компонента;
- Поставка образцов и прототипов;
- Техническая поддержка проекта;
- Защита от снятия компонента с производства.



#### Как с нами связаться

**Телефон:** 8 (812) 309 58 32 (многоканальный)

**Факс:** 8 (812) 320-02-42

**Электронная почта:** [org@eplast1.ru](mailto:org@eplast1.ru)

**Адрес:** 198099, г. Санкт-Петербург, ул. Калинина, дом 2, корпус 4, литера А.