

## UKH 95

Order No.: 3010013

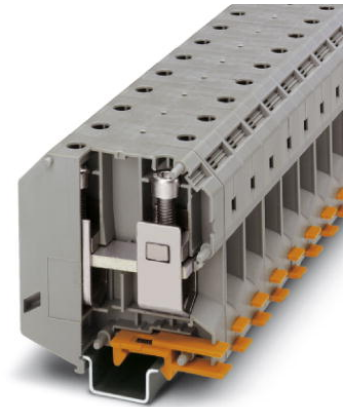

<http://eshop.phoenixcontact.de/phoenix/treeViewClick.do?UID=3010013>

Feed-through modular terminal block, Type of connection: Screw connection, Screw connection, Cross section: 25 mm<sup>2</sup> - 95 mm<sup>2</sup>, AWG 4 - 3/0, Width: 25 mm, Color: gray, Mounting type: NS 35/15, NS 32



Commercial data	
EAN	4017918091835
Pack	10 pcs.
Customs tariff	85369010
Weight/Piece	0.21314 KG
Catalog page information	Page 31 (CL-2009)

#### Product notes

WEEE/RoHS-compliant since:  
09/01/2005



<http://www.download.phoenixcontact.com>  
Please note that the data given here has been taken from the online catalog. For comprehensive information and data, please refer to the user documentation. The General Terms and Conditions of Use apply to Internet downloads.

#### Technical data

##### General

Number of levels	1
Number of connections	2
Color	gray

Insulating material	PA
Inflammability class acc. to UL 94	V0

**Dimensions**

Width	25 mm
Length	83 mm
Height NS 35/15	97.5 mm
Height NS 32	95.5 mm

**Technical data**

Maximum load current	232 A (with 95 mm <sup>2</sup> conductor cross section)
Rated surge voltage	8 kV
Pollution degree	3
Surge voltage category	III
Insulating material group	I
Connection in acc. with standard	IEC 60947-7-1
Nominal current I <sub>N</sub>	232 A
Nominal voltage U <sub>N</sub>	1000 V
Open side panel	nein

**Connection data**

Conductor cross section solid min.	25 mm <sup>2</sup>
Conductor cross section solid max.	95 mm <sup>2</sup>
Conductor cross section stranded min.	35 mm <sup>2</sup>
Conductor cross section stranded max.	95 mm <sup>2</sup>
Conductor cross section AWG/kcmil min.	4
Conductor cross section AWG/kcmil max	3/0
Conductor cross section stranded, with ferrule without plastic sleeve min.	35 mm <sup>2</sup>
Conductor cross section stranded, with ferrule without plastic sleeve max.	95 mm <sup>2</sup>
Conductor cross section stranded, with ferrule with plastic sleeve min.	35 mm <sup>2</sup>
Conductor cross section stranded, with ferrule with plastic sleeve max.	95 mm <sup>2</sup>
2 conductors with same cross section, solid min.	25 mm <sup>2</sup>
2 conductors with same cross section, solid max.	35 mm <sup>2</sup>
2 conductors with same cross section, stranded min.	25 mm <sup>2</sup>

2 conductors with same cross section, stranded max.	35 mm <sup>2</sup>
2 conductors with same cross section, stranded, ferrules without plastic sleeve, min.	16 mm <sup>2</sup>
2 conductors with same cross section, stranded, ferrules without plastic sleeve, max.	35 mm <sup>2</sup>
Cross-section with insertion bridge, solid max.	95 mm <sup>2</sup>
Cross-section with insertion bridge, stranded max.	70 mm <sup>2</sup>
Type of connection	Screw connection
Stripping length	33 mm
Screw thread	M8
Tightening torque, min	15 Nm
Tightening torque max	20 Nm

### Certificates / Approvals



Certification BV, CCA, CSA, CUL, DNV, GL, KEMA, LR, PRS, RS, UL

Certification Ex: CUL-EX, FM, IECEx, KEMA-EX, UL-EX

#### CSA

Nominal voltage U <sub>N</sub>	600 V
Nominal current I <sub>N</sub>	200 A
AWG/kcmil	2-4/0

#### CUL

Nominal voltage U <sub>N</sub>	600 V
Nominal current I <sub>N</sub>	230 A
AWG/kcmil	2-4/0

#### UL

Nominal voltage U <sub>N</sub>	600 V
Nominal current I <sub>N</sub>	230 A
AWG/kcmil	2-4/0

<b>Accessories</b>		
Item	Designation	Description
<b>Assembly</b>		
3003541	AGK 10-UKH 95	Pick-off terminal block, Type of connection: Special and hybrid connection, Cross section: 0.5 mm <sup>2</sup> - 16 mm <sup>2</sup> , AWG 20 - 6, Width: 10.2 mm, Height: 34.7 mm, Color: gray
1201659	E/AL-NS 32	End bracket, for end support of UKH 50 - UKH 240, is pushed onto DIN rail NS 32 and fixed with 2 screws, width: 10 mm, color: Aluminum
1201662	E/AL-NS 35	End bracket, for end support of UKH 50 to UKH 240, is pushed onto DIN rail NS 35 and fixed with 2 screws, width: 10 mm, color: aluminum
1201028	NS 32 AL UNPERF 2000MM	G rail 32 mm (NS 32)
1201280	NS 32 CU/120QMM UNPERF 2000MM	G-profile DIN rail, deep-drawn, material: Copper, unperforated, height 15 mm, width 32 mm, length 2 m
1201358	NS 32 CU/35QMM UNPERF 2000MM	G-profile DIN rail, material: Copper, unperforated, height 15 mm, width 32 mm, length 2 m
1201002	NS 32 PERF 2000MM	G-profile DIN rail, material: Steel, perforated, height 15 mm, width 32 mm, length 2 m
1201015	NS 32 UNPERF 2000MM	G-profile DIN rail, material: Steel, unperforated, height 15 mm, width 32 mm, length 2 m
1201756	NS 35/15 AL UNPERF 2000MM	DIN rail, deep-drawn, high profile, unperforated, 1.5 mm thick, material: Aluminum, height 15 mm, width 35 mm, length 2 m
1201895	NS 35/15 CU UNPERF 2000MM	DIN rail, material: Copper, unperforated, 1.5 mm thick, height 15 mm, width 35 mm, length: 2 m
1201730	NS 35/15 PERF 2000MM	DIN rail, material: Steel, perforated, height 15 mm, width 35 mm, length: 2 m
1201714	NS 35/15 UNPERF 2000MM	DIN rail, material: Steel, unperforated, height 15 mm, width 35 mm, length: 2 m
1201798	NS 35/15-2,3 UNPERF 2000MM	DIN rail, material: Steel, unperforated, 2.3 mm thick, height 15 mm, width 35 mm, length: 2 m
<b>Bridges</b>		
0201362	EB 2-25/UKH	Cross connector/bridge, Number of positions: 2, Color: gray
0201375	EB 3-25/UKH	Cross connector/bridge, Number of positions: 3, Color: gray
<b>Marking</b>		
1004584	WS-4K	Adhesive warning plate, self-adhesive, black print: lightning flash with mixed version - "Vorsicht Spannung - Attention Danger" size of label: 13 x 23.5 mm
0811228	X-PEN 0,35	Marker pen without ink cartridge, for manual labeling of markers, labeling extremely wipe-proof, line thickness 0.35 mm

1053001	ZB 10:UNBEDRUCKT	Zack strip, unprinted: 10-section, for individual labeling with M-PEN, ZB-T or CMS system, sufficient for 100 terminal blocks, for a terminal width of 10.2 mm, color: White
5060883	ZB10/WH-100:UNBEDRUCKT	Zack strip, unprinted: 10-section, for individual labeling with M-PEN, ZB-T or CMS system, large batch, sufficient for labeling 1000 terminal blocks, for a terminal width of 10.2 mm, color: White
1050525	ZB10:SO/CMS	Zack strip, 10-section, divisible, special printing, marking according to customer requirements
1050525	ZB10:SO/CMS	Zack strip, 10-section, divisible, special printing, marking according to customer requirements

**Plug/Adapter**

3009231	UKH 95 EP	Insertion profile
---------	-----------	-------------------

**Tools**

1201934	VDE-ISS 6	Allen wrench, fully insulated, safety tool in accordance with EN 60900, length: 150 mm, handle width: 110 mm, for all terminal blocks with 8 mm Allen screw
---------	-----------	---

**Diagrams/Drawings**

Dimensioned drawing

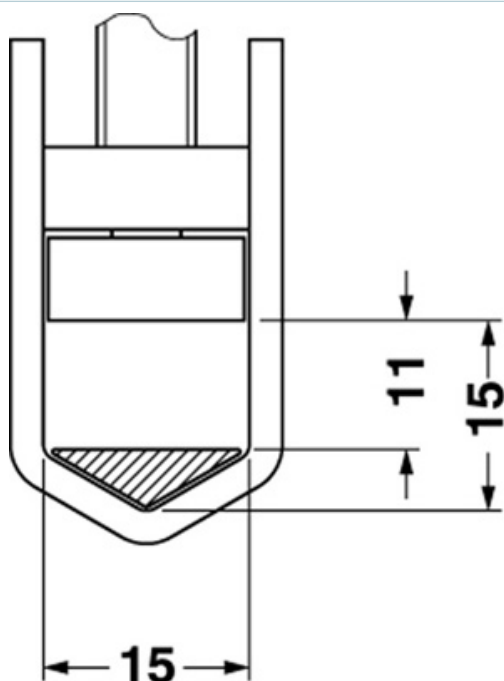

Circuit diagram



Approbationslogos (EX-Bereich)

---



**Address**

PHOENIX CONTACT Deutschland GmbH  
Flachmarktstr. 8  
32825 Blomberg, Germany  
Phone +49 5235 3 12000  
Fax +49 5235 3 41200  
<http://www.phoenixcontact.de>



© 2010 Phoenix Contact  
Technical modifications reserved;



Компания «ЭлектроПласт» предлагает заключение долгосрочных отношений при поставках импортных электронных компонентов на взаимовыгодных условиях!

Наши преимущества:

- Оперативные поставки широкого спектра электронных компонентов отечественного и импортного производства напрямую от производителей и с крупнейших мировых складов;
- Поставка более 17-ти миллионов наименований электронных компонентов;
- Поставка сложных, дефицитных, либо снятых с производства позиций;
- Оперативные сроки поставки под заказ (от 5 рабочих дней);
- Экспресс доставка в любую точку России;
- Техническая поддержка проекта, помощь в подборе аналогов, поставка прототипов;
- Система менеджмента качества сертифицирована по Международному стандарту ISO 9001;
- Лицензия ФСБ на осуществление работ с использованием сведений, составляющих государственную тайну;
- Поставка специализированных компонентов (Xilinx, Altera, Analog Devices, Intersil, Interpoint, Microsemi, Aeroflex, Peregrine, Syfer, Eurofarad, Texas Instrument, Miteq, Cobham, E2V, MA-COM, Hittite, Mini-Circuits, General Dynamics и др.);

Помимо этого, одним из направлений компании «ЭлектроПласт» является направление «Источники питания». Мы предлагаем Вам помощь Конструкторского отдела:

- Подбор оптимального решения, техническое обоснование при выборе компонента;
- Подбор аналогов;
- Консультации по применению компонента;
- Поставка образцов и прототипов;
- Техническая поддержка проекта;
- Защита от снятия компонента с производства.



#### Как с нами связаться

**Телефон:** 8 (812) 309 58 32 (многоканальный)

**Факс:** 8 (812) 320-02-42

**Электронная почта:** [org@eplast1.ru](mailto:org@eplast1.ru)

**Адрес:** 198099, г. Санкт-Петербург, ул. Калинина, дом 2, корпус 4, литера А.